

Slurry surfacing — Test methods —

Part 4: Determination of cohesion of the mix

The European Standard EN 12274-4:2003 has the status of a British Standard

ICS 93.080.20

National foreword

This British Standard is the official English language version of EN 12274-4:2003.

The UK participation in its preparation was entrusted by Technical Committee B/510, Road materials, to Subcommittee B/510/2, Surface dressing, sprays and slurry surfacing, which has the responsibility to:

- aid enquirers to understand the text;
- present to the responsible international/European committee any enquiries on the interpretation, or proposals for change, and keep the UK interests informed;
- monitor related international and European developments and promulgate them in the UK.

A list of organizations represented on this subcommittee can be obtained on request to its secretary.

Cross-references

The British Standards which implement international or European publications referred to in this document may be found in the *BSI Catalogue* under the section entitled “International Standards Correspondence Index”, or by using the “Search” facility of the *BSI Electronic Catalogue* or of British Standards Online.

This publication does not purport to include all the necessary provisions of a contract. Users are responsible for its correct application.

Compliance with a British Standard does not of itself confer immunity from legal obligations.

This British Standard was published under the authority of the Standards Policy and Strategy Committee on 21 May 2003

Summary of pages

This document comprises a front cover, an inside front cover, the EN title page, pages 2 to 15 and a back cover.

The BSI copyright date displayed in this document indicates when the document was last issued.

Amendments issued since publication

Amd. No.	Date	Comments

© BSI 21 May 2003

ISBN 0 580 41902 9

EUROPEAN STANDARD

EN 12274-4

NORME EUROPÉENNE

EUROPÄISCHE NORM

February 2003

ICS 93.080.20

English version

Slurry surfacing - Test methods - Part 4: Determination of cohesion of the mix

Matériaux bitumineux coulés à froid - Méthode d'essai -
Partie 4: Détermination de la cohésion du mélange

Dünne Asphalttschicht in Kaltbauweise - Prüfverfahren - Teil
4: Bestimmung der Kohäsion der Mischung

This European Standard was approved by CEN on 21 November 2002.

CEN members are bound to comply with the CEN/GENELEC Internal Regulations which stipulate the conditions for giving this European Standard the status of a national standard without any alteration. Up-to-date lists and bibliographical references concerning such national standards may be obtained on application to the Management Centre or to any CEN member.

This European Standard exists in three official versions (English, French, German). A version in any other language made by translation under the responsibility of a CEN member into its own language and notified to the Management Centre has the same status as the official versions.

CEN members are the national standards bodies of Austria, Belgium, Czech Republic, Denmark, Finland, France, Germany, Greece, Hungary, Iceland, Ireland, Italy, Luxembourg, Malta, Netherlands, Norway, Portugal, Slovakia, Spain, Sweden, Switzerland and United Kingdom.



EUROPEAN COMMITTEE FOR STANDARDIZATION
COMITÉ EUROPÉEN DE NORMALISATION
EUROPÄISCHES KOMITEE FÜR NORMUNG

Management Centre: rue de Stassart, 36 B-1050 Brussels

Contents

	page
Foreword.....	3
1 Scope	3
2 Normative references	4
3 Terms and definitions.....	4
4 Principle	4
5 Materials.....	5
6 Apparatus	5
7 Calibration of test apparatus	11
8 Preparation of sample	11
9 Test procedure	13
10 Expression of results	13
11 Test report	14
Bibliography	15

Foreword

This document (EN 12274-4:2003) has been prepared by Technical Committee CEN/TC 227 "Road materials", the secretariat of which is held by DIN.

This European Standard shall be given the status of a national standard, either by publication of an identical text or by endorsement, at the latest by August 2003, and conflicting national standards shall be withdrawn at the latest by December 2005.

This European Standard is one of a series of standards as listed below:

EN 12274-1, *Slurry surfacing Test methods Part 1: Sampling for binder extraction.*

EN 12274-2, *Slurry surfacing Test methods Part 2: Determination of residual binder content.*

EN 12274-3, *Slurry surfacing Test methods Part 3: Consistency.*

EN 12274-4, *Slurry surfacing Test methods Part 4: Determination of cohesion of the mix.*

EN 12274-5, *Slurry surfacing Test methods Part 5: Determination of wearing.*

EN 12274-6, *Slurry surfacing Test methods Part 6: Rate of application.*

EN 12274-7¹, *Slurry surfacing Test methods Part 7: Shaking abrasion test in suitability of mineral aggregates to slurry mixes.*

EN 12274-8¹, *Slurry surfacing Test methods Part 8: Visual assessment.*

According to the CEN/CENELEC Internal Regulations, the national standards organizations of the following countries are bound to implement this European Standard: Austria, Belgium, Czech Republic, Denmark, Finland, France, Germany, Greece, Hungary, Iceland, Ireland, Italy, Luxembourg, Malta, Netherlands, Norway, Portugal, Slovakia, Spain, Sweden, Switzerland and the United Kingdom.

1 Scope

This European Standard describes a test method for determining the minimum cohesion of a slurry surfacing mix which enables the set time and trafficability time to be determined.

This European Standard applies to slurry surfacing to be used in surface layers.

NOTE For some coarse mixtures the precision is poor due to loss of aggregates comes up, a comment will be made in the report.

¹ In preparation.

2 Normative references

This European Standard incorporates by dated or undated reference, provisions from other publications. These normative references are cited at the appropriate places in the text, and the publications are listed hereafter. For dated references, subsequent amendments to or revisions of any of these publications apply to this European Standard only when incorporated in it by amendment or revision. For undated references the latest edition of the publication referred to applies (including amendments).

EN 12274-3, *Slurry surfacing — Test methods — Part 3: Consistency*.

ISO 48, *Rubber, vulcanized or thermoplastic — Determination of hardness (Hardness between 10 IRHD and 100 IRHD)*.

3 Terms and definitions

For the purposes of this European Standard, the following terms and definitions apply.

3.1

set

end of the non-reversible process in a slurry surfacing when the emulsion coalescence takes place

NOTE 1 The coalescence of an emulsion is the non-reversible phase starting from the beginning of the breaking of the emulsion to the total setting when the bitumen emulsion reverts to bitumen in presence of a mineral.

NOTE 2 After the set of a slurry surfacing

- it is not possible to stir the mixture;
- free emulsion during washing with water cannot be observed;
- an absorbent paper is not stained when pressed slightly onto the surface of the slurry.

3.2

set time

time elapsed between placing a slurry surfacing and its setting

3.3

trafficability time

period of time after laying, when the slurry surfacing can accept traffic

3.4

quick setting slurry

slurry with a set time less than or equal to 30 min

3.5

slow setting slurry

slurry with a set time more than 30 min

4 Principle

Torque measurements are taken on five samples of the same slurry mix at suitable intervals after casting.

5 Materials

5.1 Coarse aggregates and sand

A sufficient amount of the separated aggregates to be used in the slurry shall be dried in an oven at $(110 \pm 5) ^\circ\text{C}$ to reach constant mass.

NOTE Constant mass is deemed to be achieved when the difference between successive weighings at 30 min intervals does not exceed 0,1 % of the mass.

5.2 Reactive filler

The filler, e.g. cement or hydrated lime, shall be dried in an oven at $(110 \pm 5) ^\circ\text{C}$ to reach a constant mass.

NOTE Constant mass is deemed to be achieved when the difference between successive weighings at 30 min intervals does not exceed 0,1 % of the mass.

5.3 Emulsion

The emulsion shall be manually homogenized using a glass rod.

6 Apparatus

6.1 Apparatus used for preparation of samples

6.1.1 **Oven**, with a minimum capacity of 80 l capable of maintaining a temperature of $(110 \pm 5) ^\circ\text{C}$.

6.1.2 **Balance**, accurate to 0,1 g.

6.1.3 **Timing device**, accurate to 1 s.

6.1.4 Metal square-shaped moulds, having four trunco-conical holes (see Figure 1) of the dimensions given in Table 1.

Table 1 — Dimensions of moulds

Moulds	Dimensions							
	Width (W) mm	Length (L) mm	Height (H) mm	Hole diameter		Tolerances		
				mm		mm		
				upper D	lower D'	(W),(L)	(H)	(D,D')
Type A	140	140	6,3	60	60,3	1 %	1 %	1 %
Type B	140	140	10,0	60	60,4			
Type C	200	200	13,0	90	90,6			
Type D	250	250	19,0	115	115,8			

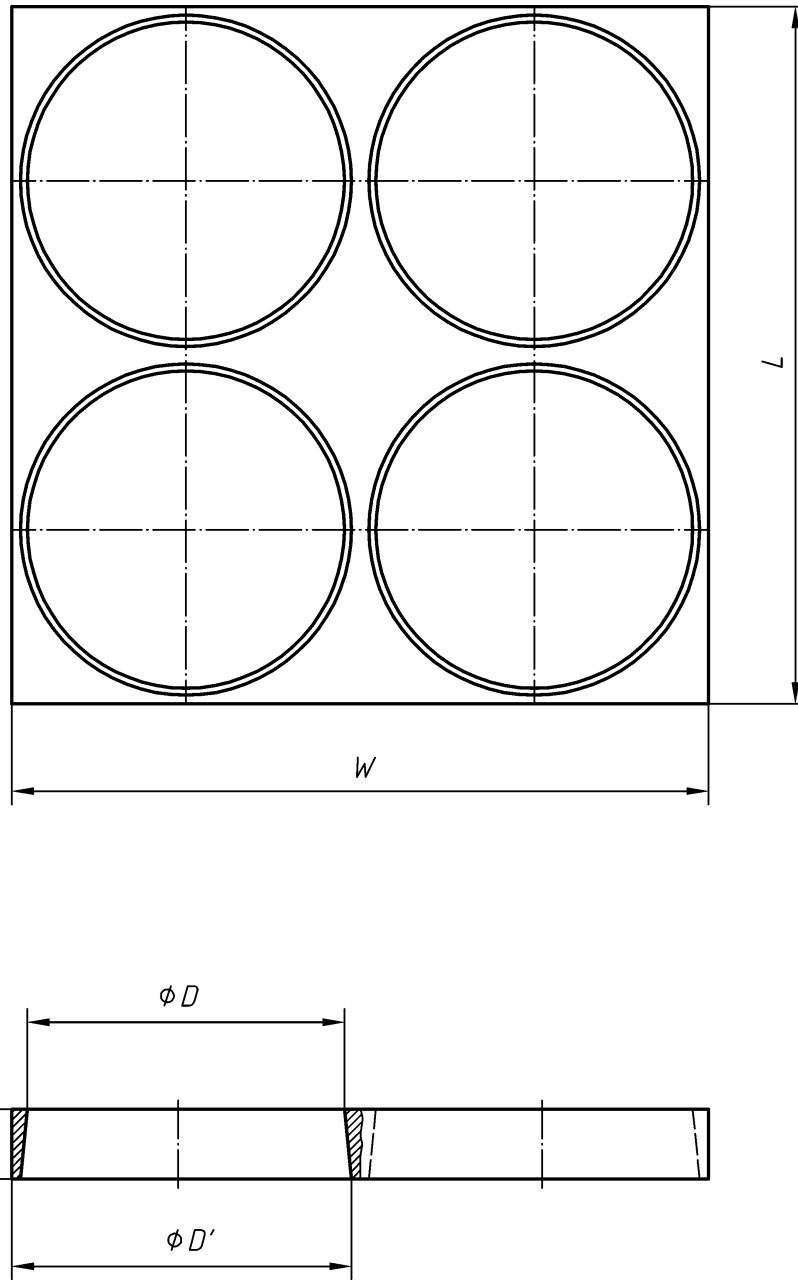
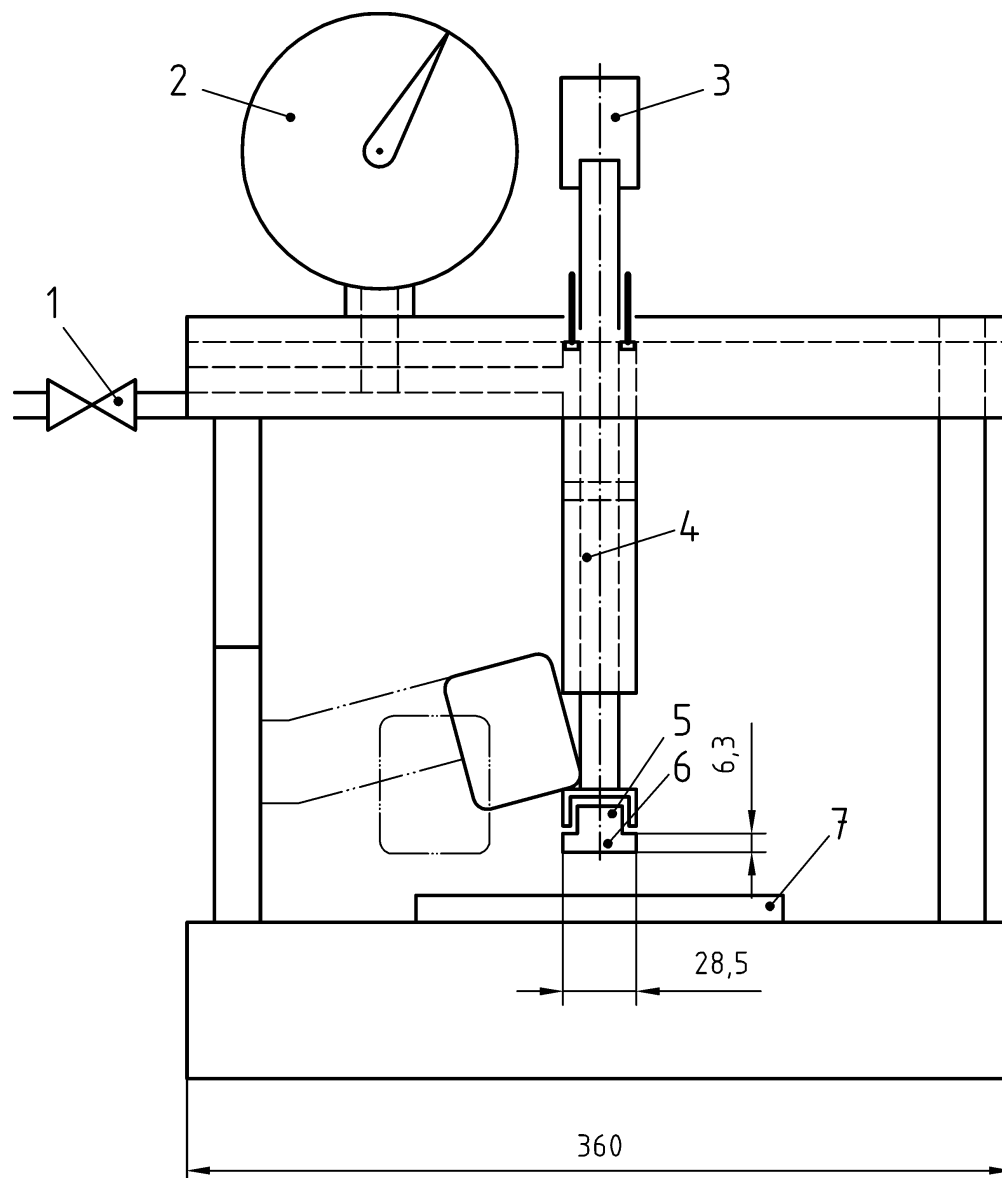

Figure 1 — Metal square-shaped moulds, upper view, side view

Dimensions in millimetres

**Key**

- 1 Control valve
- 2 Air pressure gauge
- 3 Drive socket for straight handle of torquemeter
- 4 Double acting double endrod pneumatic cylinder
- 5 Rubber foot
- 6 Autotire plug
- 7 Sample

Figure 2 — Metal square-shape moulds, front view

EN 12274-4:2003 (E)

6.1.5 End-rounded spatula, or metal rod.

6.1.6 **Ladles or beakers**, of 1 l and 2 l capacity.

6.1.7 **Roofing felt**, for sample holder of the same dimensions as the moulds of (700 ± 70) g/m².

6.2 Apparatus used for testing

6.2.1 Cohesion tester

6.2.1.1 General

A cohesion tester, as shown in Figures 2 to 4, shall consist of the elements described in 6.2.1.2 to 6.2.1.7:

6.2.1.2 Double rod end air cylinder, 28,5 mm in diameter, with 8 mm diameter rods and 76 mm stroke.

6.2.1.3 Neoprene rubber foot, (60 ± 2) degrees durometer in accordance with ISO 48, 6,3 mm height and 28,5 mm in diameter.

6.2.1.4 Air pressure regulator, with a variable down stream bleed valve so that constant pressure is maintained.

6.2.1.5 Four-way directional control valve, with exhaust port regulating valves.

6.2.1.6 Air pressure gauge, with a 0 kPa to 700 kPa pressure gauge.

6.2.1.7 Torque meter, capable of measuring and recording at least 3,5 Nm (35 kg/cm) torque.

6.2.2 **Air supply**, of 700 kPa.

Dimensions in millimetres

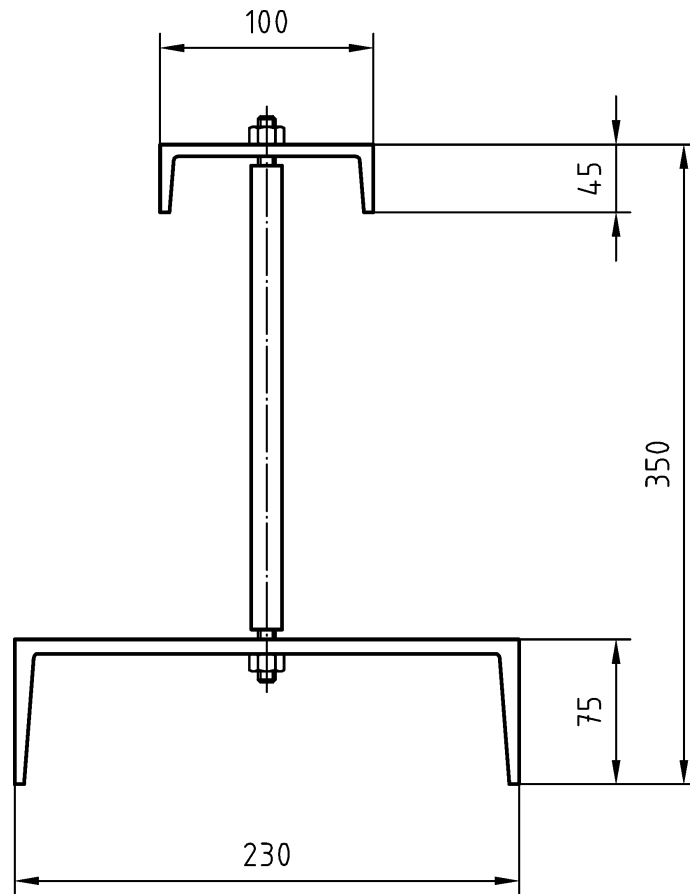

NOTE Tolerance for the dimensions: 1 %

Figure 3 — Cohesion tester, side view



NOTE Tolerance for the dimensions: 1 %

Figure 4 — Cohesion tester, side view

7 Calibration of test apparatus

7.1 Materials

7.1.1 Calibrated sand, with a grading curve in accordance with Table 2.

Table 2 — Grading curve of calibrated sand

Sieve mm	Passing %
1	85 to 100
0,5	0 to 5

7.1.2 P220 grit silicon carbide sand paper.

7.1.3 P100 grit silicon carbide sand paper.

NOTE P220 and P100 according to FEPA system (see Bibliography).

7.2 Procedure

Place the 220 grit sand paper in the cohesion tester and make up to 10 measurements in accordance with clause 9 (with the exception of the time intervals) in order to polish the rubber foot. Continue tests until a constant reading is achieved.

Once the rubber foot is polished, place the calibrated sand in the 10 mm high mould and take a series of measurements with the torque meter in accordance with clause 9 (with the exception of the time intervals) until a constant reading is achieved.

Place the 100 grit sand paper in the cohesion tester and make a series of measurements in accordance with clause 9 (with the exception of the time intervals) until a constant reading is achieved.

The cohesion tester shall then be deemed to be calibrated.

The calibration shall be carried out at least once per year.

8 Preparation of sample

8.1 Temperature

All materials that are going to be used in sample preparation shall remain at temperature of $(23 \pm 2) ^\circ\text{C}$ for at least 2 h before testing.

8.2 Water

The proportion of water shall be previously determined according to EN 12274-3.

NOTE In quick setting slurries, this test is sometimes difficult to carry out. In such cases the amount of water should be determined by observation to ensure complete homogeneity.

8.3 Aggregates and filler

Weigh aggregates and filler in the same proportions as the design mix and place into a ladle or beaker of a size conforming to Table 3 and mix with a spatula until a homogeneous mixture is obtained (approximately 1 min).

Table 3 — Sample size

Maximum aggregate size mm	Amount of aggregates and filler g	Ladle or beaker size l
4	400	1
5,6		
6,3		
8		
10	900	2
11,2		
16		

8.4 Water and additive

Add water and additive, (if necessary) and stir the mixture until all the aggregates and filler are completely wetted.

The calcium carbonate content of the water shall be less than 250 ppm.

8.5 Preparation of the mix

Add the corresponding amount of emulsion to that required in the design and stir using a spatula or metal rod until a visual homogeneous mixture is obtained. The mixing time for quick setting slurries shall be (45 ± 1) s and for slow setting slurries shall be between (60 ± 1) s and (180 ± 1) s.

8.6 Sample size

Prepare the sample in metal square-shape moulds corresponding to the maximum size of the aggregate in accordance with Table 4.

Table 4 — Mould size

Maximum aggregate size mm	Mould size
4,0	A
5,6	
6,3	B
8,0	
10,0	C
11,2	
16,0	D

Centre the mould over the supports and pour the slurry into it. Spread the sample and level it until a level, uniform and smooth surface is obtained. During this operation the handling of the slurry shall be minimized to avoid segregation.

8.7 Curing

Remove the moulds after the setting of the mix and keep the samples at a test temperature of $(23 \pm 2) ^\circ\text{C}$.

9 Test procedure

Torque measurements shall be made at intervals of 15 min, 30 min, 60 min, 90 min and 120 min after casting.

NOTE 1 These intervals are provisional and should be confirmed by Round Robin Tests.

The test shall be performed at $(23 \pm 2) ^\circ\text{C}$.

NOTE 2 For particular purposes, the torque test may be performed at other fixed temperatures.

Centre the specimen under the neoprene foot, with the instrument air pressure set at $(200 \pm 4) \text{ kPa}$, and lower the foot against the specimen at a rate of 80 mm/s to 100 mm/s.

Placing the foot, zero the torque meter and place it on the top cylinder rod-end and twist it in a smooth, firm, horizontal motion through a 90° to 120° arc within 0,5 s to 0,7 s.

Record the torque reading and the time.

10 Expression of results

Results shall be recorded at the time intervals mentioned in clause 9 until a definite trend is established and plotted onto graph paper.

NOTE When plotted onto graph paper to a suitable scale, the characteristics curve showing the development of cohesive strength of the particular mix tested will be indicated. The graph should show the calibration values.

11 Test report

The test report shall state that the test has been performed in accordance with this European Standard and shall contain the following information:

- a) type and size of aggregates used;
- b) type and amount of filler used;
- c) type and amount of emulsion used;
- d) type and amount of additives used;
- e) date of test;
- f) location of test;
- g) name of the person responsible for the test;
- h) results as calculated in clause 10;
- i) remarks;
- j) signature of the person responsible for the test.

Bibliography

ASTM D-3910-90, *Standard practices for design, testing and construction of slurry seal*

ISSA n° 139-90, *Test method to classify emulsified asphalt-aggregate mixture systems by modified cohesion tester measurement of set and cure characteristics.*

Benedict, C. R., *Classification of asphalt emulsion-aggregate systems by cohesion tester measurement of set and cure characteristics.* Proc 21st ISSA Conv. Phoenix, AZ, 1983.

FEPA, Fédération Européenne des Produits Abrasifs, 20 avenue Reille, F-75014 Paris.

BSI — British Standards Institution

BSI is the independent national body responsible for preparing British Standards. It presents the UK view on standards in Europe and at the international level. It is incorporated by Royal Charter.

Revisions

British Standards are updated by amendment or revision. Users of British Standards should make sure that they possess the latest amendments or editions.

It is the constant aim of BSI to improve the quality of our products and services. We would be grateful if anyone finding an inaccuracy or ambiguity while using this British Standard would inform the Secretary of the technical committee responsible, the identity of which can be found on the inside front cover.
Tel: +44 (0)20 8996 9000. Fax: +44 (0)20 8996 7400.

BSI offers members an individual updating service called PLUS which ensures that subscribers automatically receive the latest editions of standards.

Buying standards

Orders for all BSI, international and foreign standards publications should be addressed to Customer Services. Tel: +44 (0)20 8996 9001.
Fax: +44 (0)20 8996 7001. Email: orders@bsi-global.com. Standards are also available from the BSI website at <http://www.bsi-global.com>.

In response to orders for international standards, it is BSI policy to supply the BSI implementation of those that have been published as British Standards, unless otherwise requested.

Information on standards

BSI provides a wide range of information on national, European and international standards through its Library and its Technical Help to Exporters Service. Various BSI electronic information services are also available which give details on all its products and services. Contact the Information Centre.
Tel: +44 (0)20 8996 7111. Fax: +44 (0)20 8996 7048. Email: info@bsi-global.com.

Subscribing members of BSI are kept up to date with standards developments and receive substantial discounts on the purchase price of standards. For details of these and other benefits contact Membership Administration.
Tel: +44 (0)20 8996 7002. Fax: +44 (0)20 8996 7001.
Email: membership@bsi-global.com.

Information regarding online access to British Standards via British Standards Online can be found at <http://www.bsi-global.com/bsonline>.

Further information about BSI is available on the BSI website at <http://www.bsi-global.com>.

Copyright

Copyright subsists in all BSI publications. BSI also holds the copyright, in the UK, of the publications of the international standardization bodies. Except as permitted under the Copyright, Designs and Patents Act 1988 no extract may be reproduced, stored in a retrieval system or transmitted in any form or by any means – electronic, photocopying, recording or otherwise – without prior written permission from BSI.

This does not preclude the free use, in the course of implementing the standard, of necessary details such as symbols, and size, type or grade designations. If these details are to be used for any other purpose than implementation then the prior written permission of BSI must be obtained.

Details and advice can be obtained from the Copyright & Licensing Manager.
Tel: +44 (0)20 8996 7070. Fax: +44 (0)20 8996 7553.
Email: copyright@bsi-global.com.