

BS EN 12227:2010



BSI Standards Publication

Playpens for domestic use — Safety requirements and test methods

bsi.

...making excellence a habit.™

National foreword

This British Standard is the UK implementation of EN 12227:2010. It supersedes BS EN 12227-1:1999 and BS EN 12227-2:1999 which are withdrawn

The UK participation in its preparation was entrusted to Technical Committee CW/1/5, Nursery furniture.

A list of organizations represented on this committee can be obtained on request to its secretary.

This publication does not purport to include all the necessary provisions of a contract. Users are responsible for its correct application.

© BSI 2011

ISBN 978 0 580 61496 5

ICS 97.140; 97.190

Compliance with a British Standard cannot confer immunity from legal obligations.

This British Standard was published under the authority of the Standards Policy and Strategy Committee on 31 March 2011.

Amendments issued since publication

Date	Text affected
------	---------------

English Version

Playpens for domestic use - Safety requirements and test methods

Parcs à usage domestique - Exigences de sécurité et méthodes d'essai

Kinderlaufställe für den Wohnbereich - Sicherheitstechnische Anforderungen und Prüfungen

This European Standard was approved by CEN on 19 July 2010.

CEN members are bound to comply with the CEN/CENELEC Internal Regulations which stipulate the conditions for giving this European Standard the status of a national standard without any alteration. Up-to-date lists and bibliographical references concerning such national standards may be obtained on application to the CEN Management Centre or to any CEN member.

This European Standard exists in three official versions (English, French, German). A version in any other language made by translation under the responsibility of a CEN member into its own language and notified to the CEN Management Centre has the same status as the official versions.

CEN members are the national standards bodies of Austria, Belgium, Bulgaria, Croatia, Cyprus, Czech Republic, Denmark, Estonia, Finland, France, Germany, Greece, Hungary, Iceland, Ireland, Italy, Latvia, Lithuania, Luxembourg, Malta, Netherlands, Norway, Poland, Portugal, Romania, Slovakia, Slovenia, Spain, Sweden, Switzerland and United Kingdom.

EUROPEAN COMMITTEE FOR STANDARDIZATION
COMITÉ EUROPÉEN DE NORMALISATION
EUROPÄISCHES KOMITEE FÜR NORMUNG**Management Centre: Avenue Marnix 17, B-1000 Brussels**

Contents

Page

Foreword.....	4
Introduction	5
1 Scope	6
2 Normative references	6
3 Terms and definitions	6
4 Test equipment	7
4.1 Hip probe	7
4.2 Foothold template.....	8
4.3 Head probes	8
4.4 Template for V and irregular shaped openings	10
4.5 Finger probes	10
4.6 Protruding parts test equipment.....	11
4.7 Small parts cylinder.....	12
4.8 Feeler gauge.....	12
4.9 Bite tester	13
4.10 Base impacter	14
4.11 Side impacter	14
4.12 Loading pad.....	15
4.13 Retaining blocks for strength of mesh.....	15
4.14 Masses	16
4.15 Stops	16
4.16 Floor surface	16
4.17 Test mattress.....	16
5 General.....	16
5.1 Product conditioning.....	16
5.2 Test conditions	16
5.3 Application of forces	16
5.4 Tolerances	16
5.5 Prevention of movement of the playpen during testing	17
5.6 Order of tests	17
6 Chemical hazards	17
7 Thermal hazards	18
8 Mechanical hazards	18
8.1 Child retention function	18
8.2 Requirements for castors/wheels	24
8.3 Entrapment	25
8.4 Hazards from moving parts	28
8.5 Entanglement	28
8.6 Choking and ingestion hazards	30
8.7 Suffocation hazards.....	32
8.8 Hazardous edges and projections	32
8.9 Stuctural integrity	32
8.10 Stability	38
9 Product information.....	39
9.1 General.....	39
9.2 Marking	39
9.3 Purchase information.....	39

9.4	Instructions for use	39
10	Test report.....	40
Annex A	(informative) Rationales for inclusion of requirements for domestic playpens	41
A.1	General	41
A.2	Chemical hazards	41
A.3	Thermal hazards	41
A.3.1	Flammability.....	41
A.3.2	Flash effect.....	41
A.4	Mechanical hazards.....	41
A.4.1	General	41
A.4.2	Child retention function	42
A.4.3	Entrapment hazards	42
A.4.4	Hazards from moving parts	43
A.4.5	Entanglement.....	43
A.4.6	Detachable components	43
A.4.7	Hazardous edges and projections	44
A.4.8	Structural integrity	44
A.4.9	Stability.....	44
Annex B	(informative) Examples for the design of safe edges and corners	45
Bibliography	47

Foreword

This document (EN 12227:2010) has been prepared by Technical Committee CEN/TC 207 "Furniture", the secretariat of which is held by UNI.

This European Standard shall be given the status of a national standard, either by publication of an identical text or by endorsement, at the latest by February 2011, and conflicting national standards shall be withdrawn at the latest by February 2011.

Attention is drawn to the possibility that some of the elements of this document may be the subject of patent rights. CEN [and/or CENELEC] shall not be held responsible for identifying any or all such patent rights.

This document supersedes EN 12227-1:1999 and EN 12227-2:1999.

According to the CEN/CENELEC Internal Regulations, the national standards organizations of the following countries are bound to implement this European Standard: Austria, Belgium, Bulgaria, Croatia, Cyprus, Czech Republic, Denmark, Estonia, Finland, France, Germany, Greece, Hungary, Iceland, Ireland, Italy, Latvia, Lithuania, Luxembourg, Malta, Netherlands, Norway, Poland, Portugal, Romania, Slovakia, Slovenia, Spain, Sweden, Switzerland and the United Kingdom.

Introduction

If additional products are designed to be attached to the playpen, a hazard and risk analysis should be undertaken to identify any potential hazards.

1 Scope

This European Standard specifies the safety requirements and test methods for playpens and folding playpens for domestic use, for a child with a body weight up to 15 kg.

If a playpen has several functions or can be converted into another function, it shall comply with the relevant standards.

2 Normative references

The following referenced documents are indispensable for the application of this document. For dated references, only the edition cited applies. For undated references, the latest edition of the referenced document (including any amendments) applies.

EN 71-1, *Safety of toys — Part 1: Mechanical and physical properties*

EN 71-2, *Safety of toys — Part 2: Flammability*

EN 71-3, *Safety of toys — Part 3: Migration of certain elements*

EN 1103, *Textiles — Fabrics for apparel — Detailed procedure to determine the burning behaviour*

EN ISO 2439:2008, *Flexible cellular polymeric materials — Determination of hardness (indentation technique) (ISO 2439:2008)*

ISO 7619-2, *Rubber, vulcanized or thermoplastic — Determination of indentation hardness — Part 2: IRHD pocket meter method*

3 Terms and definitions

For the purposes of this document, the following terms and definitions apply.

**3.1
playpen**
enclosure comprising barrier and integral base intended to retain a child whilst allowing it space in which to play

**3.2
folding playpen**
playpen which can be folded or dismantled without the use of a tool for transportation or storage

**3.3
grab handle**
part attached to the playpen to assist the child within the playpen to attain and maintain a standing position

**3.4
barrier**
structure which forms the outer perimeter of the playpen, which may be continuous or comprise several components

**3.5
base**
structure forming the floor of the playpen to support the child

3.6

accessible parts

<when a child's hand cannot reach through the barrier> inside of the playpen and exterior of the playpen 300 mm from the upper part of the rim

<when a child's hand can reach through a barrier> whole playpen except the underside of the playpen base

4 Test equipment

4.1 Hip probe

The hip probe shall be made from plastics or other hard, smooth material with the dimensions given in Figure 1.

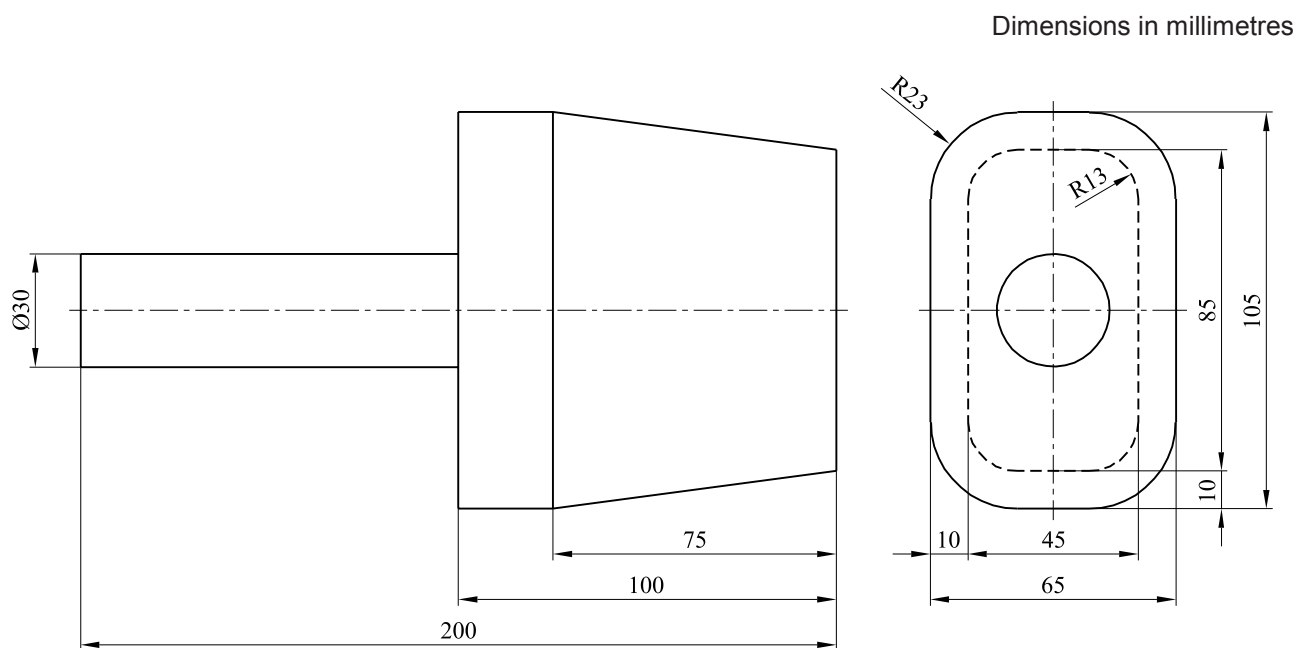

Key

- 1 Hip probe
- 2 Handle
- 3 Diameter

NOTE Tolerances on dimensions:

$$\left(\begin{array}{c} 65 \\ 0 \\ -0,5 \end{array} \right) \text{ mm}$$

$$\left(\begin{array}{c} 105 \\ 0 \\ -0,5 \end{array} \right) \text{ mm}$$

$$(30 \pm 5) \text{ mm}$$

$$(200 \pm 5) \text{ mm}$$

All other dimensions as per general tolerances (see 5.4).

Figure 1 — Hip probe with handle

4.2 Foothold template

A strip of 10 mm thick transparent material cut to the shape as shown in Figure 2.

The sides of the template shall be square to the faces. All edges and corners shall be left as machined without any radius.

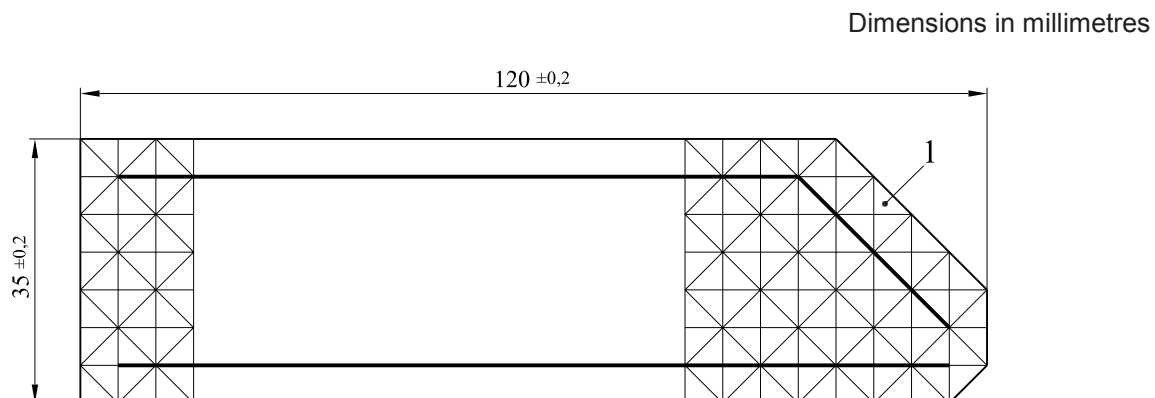

Key

- 1 Triangular cells plotted on a 5 mm × 5 mm grid

Figure 2 — Template for foothold test (example of left hand template)

Two templates are required to provide a left and right hand template. The markings shown in Figure 2 are on the bottom face of each template to avoid parallax errors.

4.3 Head probes

4.3.1 Small head probe

The small head probe, representing a child aged three months to six months, shall be made from plastics or other hard, smooth material with the dimensions given in Figure 3.

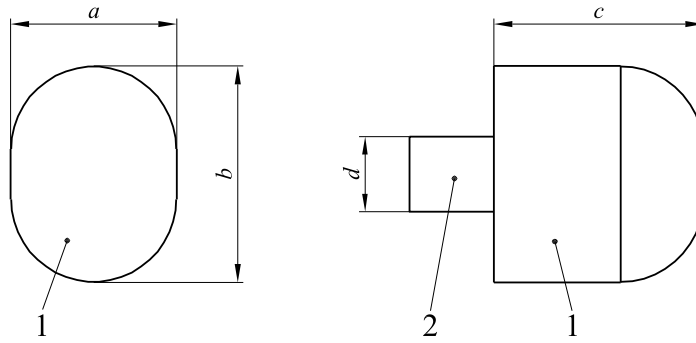

Key

$$a = \left(101 \begin{smallmatrix} 0 \\ -0,5 \end{smallmatrix} \right) \text{mm}$$

$$b = \left(137 \begin{smallmatrix} 0 \\ -0,5 \end{smallmatrix} \right) \text{mm}$$

$$c = 119 \text{ mm}$$

$$d = (45 \pm 5) \text{ mm}$$

- 1 Small head probe
- 2 Handle

Figure 3 — Small head probe with handle

4.3.2 Large head probe

The large head probe shall be made from plastics or other hard, smooth material with the dimensions given in Figure 4.

Dimensions in millimetres

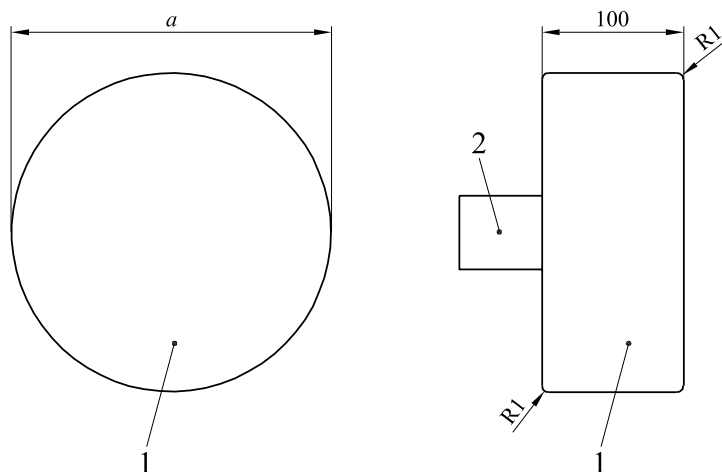

Key

$$a = \left(223 \begin{smallmatrix} +0,5 \\ 0 \end{smallmatrix} \right) \text{mm}$$

- 1 Large head probe
- 2 Handle

Figure 4 — Large head probe with handle

4.4 Template for V and irregular shaped openings

The template for V and irregular shaped openings shall be made from plastics or other hard, smooth material with the dimensions given in Figure 5.

The tolerance of the angles is $\pm 1^\circ$.

Dimensions in millimetres

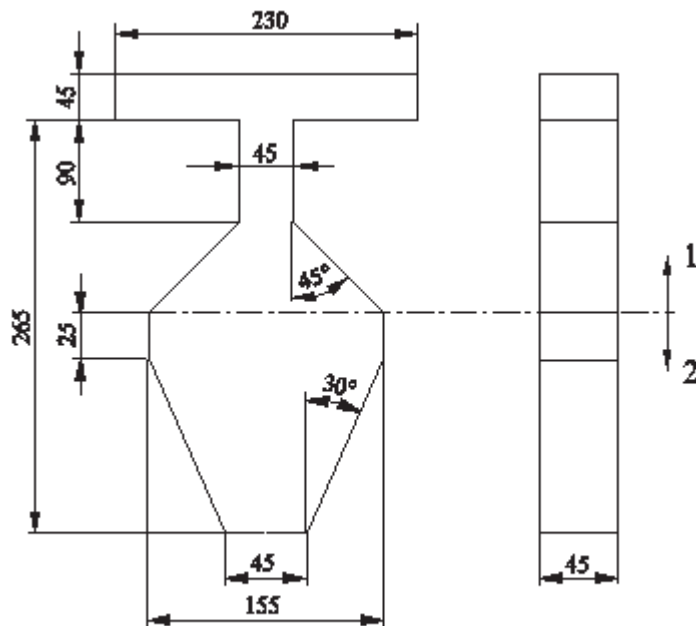

Key

- 1 B portion
- 2 A portion

Figure 5 — V and irregular shaped openings template

4.5 Finger probes

Probes made from plastics or other hard, smooth material of diameters 7 mm and 12 mm with a full hemispherical end that can be mounted on a force-measuring device, see Figure 6.

Probe for assessing mesh made from plastics or other hard, smooth material as shown in Figure 7.

Dimensions in millimetres

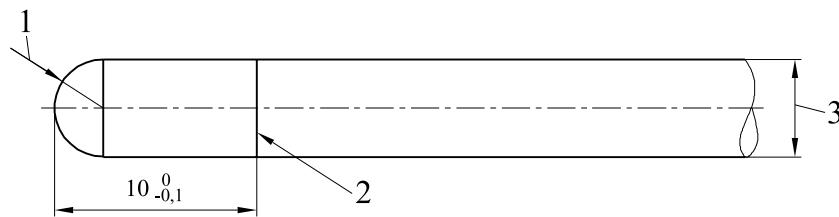

Key

- 1 R3,5 or R6
- 2 Line scribed around circumference showing depth of penetration
- 3 $\varnothing 7^{(0, -0,1)}$ mm or $\varnothing 12^{(0,1)}$ mm

Figure 6 — 7 mm and 12 mm diameter probes

Dimensions in millimetres

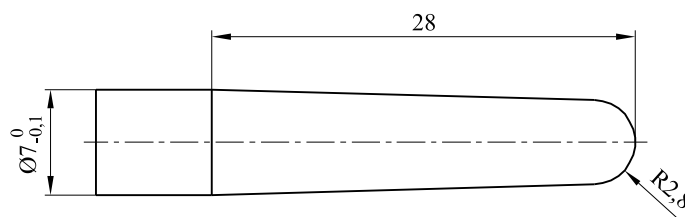
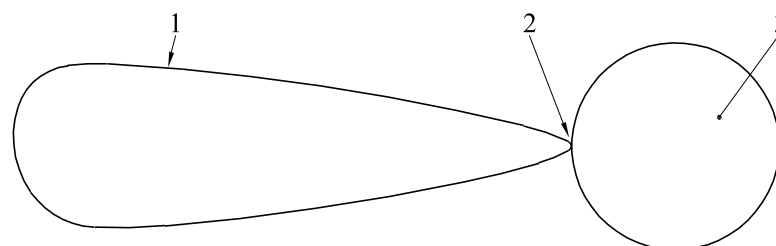

Figure 7 — 7 mm diameter probe for mesh

4.6 Protruding parts test equipment

4.6.1 Ball chain loop and spherical mass

This comprises a ball chain loop attached to a spherical mass, see Figure 8.



Key

- 1 Ball chain loop (4.6.2)
- 2 Common fixing point at the spherical mass
- 3 Spherical mass (4.6.3)

Figure 8 — Loop and mass

4.6.2 Ball chain

Ball chain with peripheral length of (400 ± 5) mm comprises a maximum of ten balls per 40 mm between ball centres of $(4,0 \pm 0,2)$ mm, see Figure 9, when the chain is loaded with a mass of 2,5 kg.

The diameter of each ball is $(3,2 \pm 0,2)$ mm, see Figure 9.

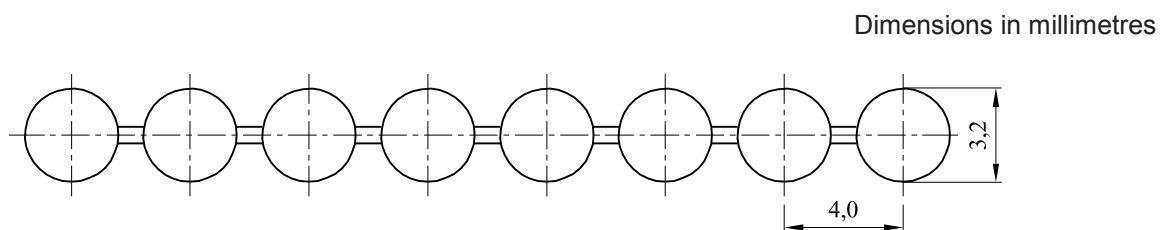

Figure 9 — Ball chain

4.6.3 Spherical mass

A smooth spherical mass of $(2,5 \pm 0,5)$ kg and 115 mm diameter.

4.7 Small parts cylinder

Cylinder, having the main dimensions given in Figure 10.

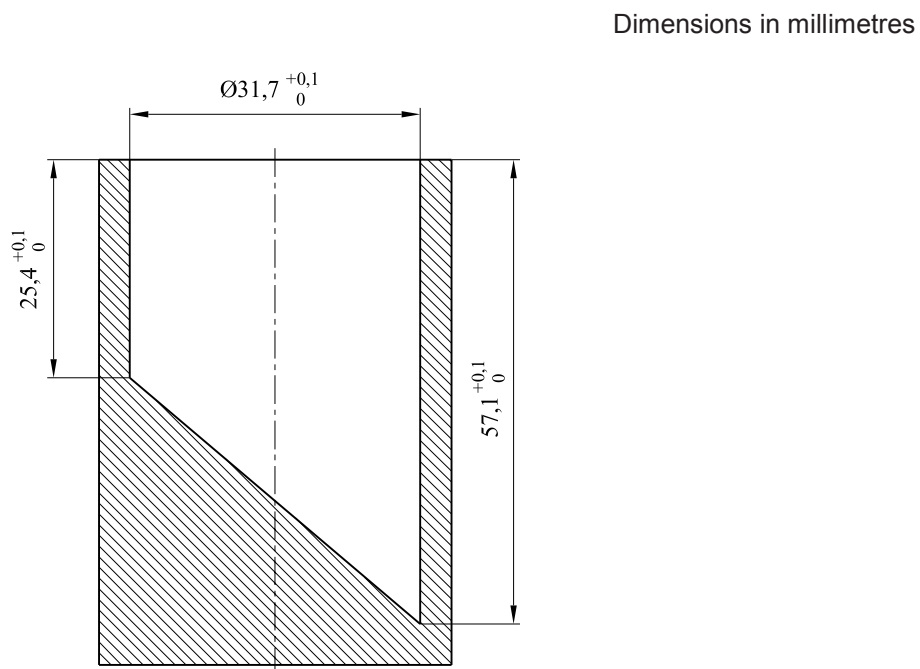

Figure 10 — Small parts cylinder

4.8 Feeler gauge

Feeler gauge with the dimensions given in Figure 11.

Dimensions in millimetres

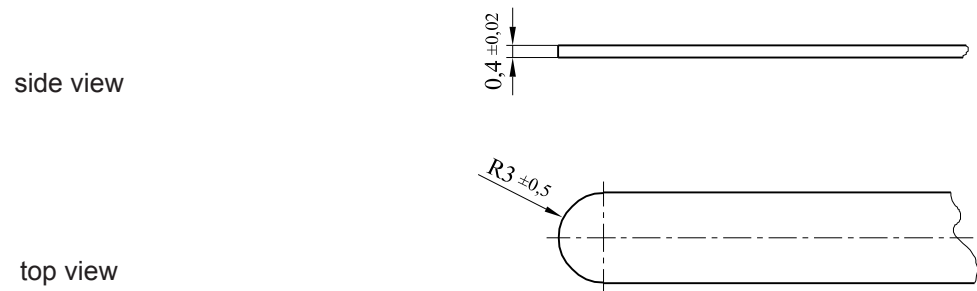

Figure 11 — Feeler gauge

4.9 Bite tester

The bite tester, see Figure 12, consists of two sets of teeth, see Figure 13, made from H13 high chrome tool steel or equivalent and hardened to 45-50 Rockwell C. There are two teeth at the top and two at the bottom of the bite tester, positioned so that the vertical centre line of one pair of teeth is $(1 \pm 0,1)$ mm in front of the centre line of the other set of teeth. In the fully closed position the teeth shall overlap each other by $(1 \pm 0,1)$ mm. The outer most corners of the teeth shall have a radius of $(0,3 \pm 0,1)$ mm.

The teeth shall be mounted so as to pivot about a point (50 ± 1) mm from the rear most pair of teeth and positioned so that when closed the centre lines of the two pairs of teeth are parallel to each other. The bite tester shall be equipped with a stop to prevent the distance between the teeth from exceeding (28 ± 1) mm when fully opened. The closing force of the teeth shall be set at (50 ± 5) N.

The bite tester shall be provided with a guide to prevent items entering further into the fully opened jaws by more than (17 ± 1) mm. The bite tester shall be equipped with a means whereby a force of (50 ± 5) N may be applied along its centre line in a direction tending to pull the teeth off the sample.

Dimensions in millimetres

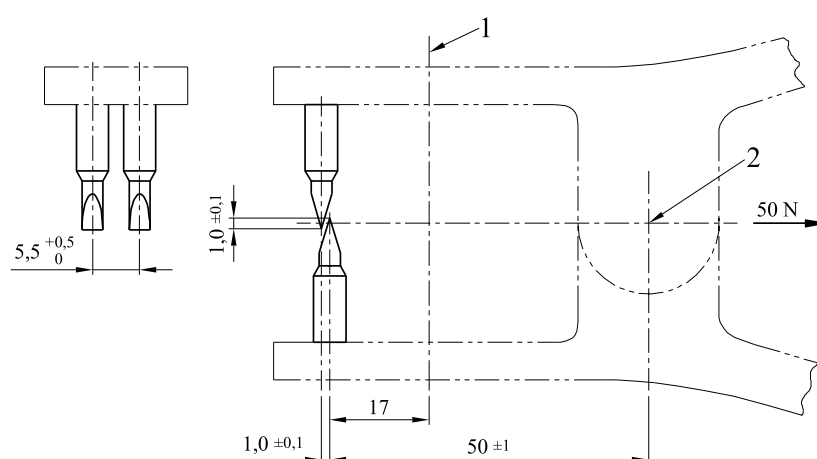

Key

- 1 Position of guide
- 2 Pivot point

Figure 12 — Bite tester

Dimensions in millimetres

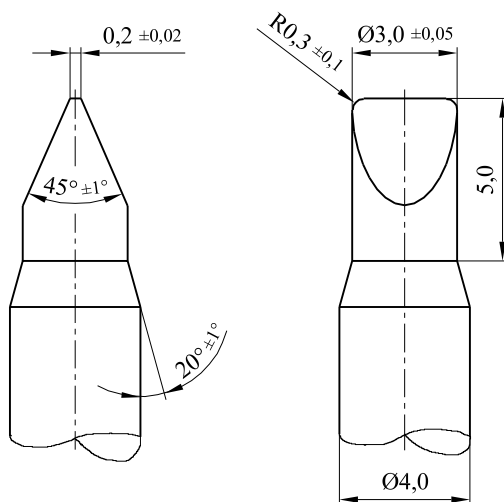

Figure 13 — Test teeth

4.10 Base impacter

An impacter with a total mass of 10 kg made of hardwood or equivalent material, with the dimensions given in Figure 14.

The impacter shall be guided so that it is kept upright and always falls on the impact point.

Dimensions in millimetres

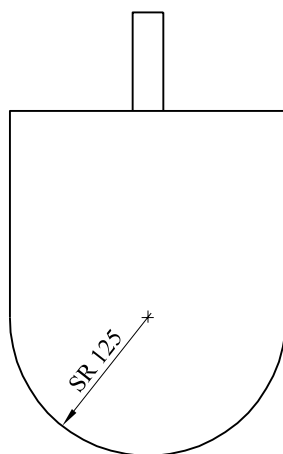

Key

SR Spherical radius

Figure 14 — Base impacter

4.11 Side impacter

A pendulum with a cylindrical head made of steel with the dimensions given in Figure 15. The head of the pendulum shall be surrounded by a 10 mm thick layer of rubber of hardness 76 IRHD to 78 IRHD in accordance with ISO 7619-2. The total mass shall be 2 kg.

Dimensions in millimetres

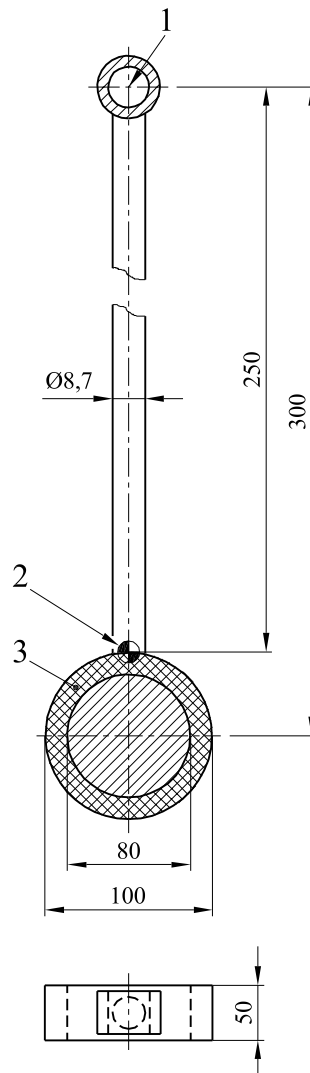

Key

- 1 Pivot point
- 2 Centre of gravity
- 3 Rubber 76 to 78 IRHD

Figure 15 — Side impacter

4.12 Loading pad

A rigid cylinder of 100 mm diameter having a smooth hard surface and rounded edges with a radius of 12 mm.

4.13 Retaining blocks for strength of mesh

Two retaining blocks made of a rigid material with a support surface for the playpen rim of 100 mm × 100 mm and a radius of 5 mm on the edges.

4.14 Masses

4.14.1 Mass of 15 kg and cross section of 100 mm × 100 mm.

4.14.2 Mass of 20 kg distributed evenly over an area of 150 mm × 150 mm.

4.15 Stops

Stops which prevent the article from sliding but not tilting, not higher than 12 mm except in cases where the design of the item necessitates the use of higher stops, in which case the lowest that will prevent the item from sliding shall be used.

4.16 Floor surface

Horizontal, rigid and flat surface.

4.17 Test mattress

A PUR foam sheet with a thickness of 60 mm, a bulk density of (35 ± 2) kg/m³ and an indentation hardness index of (170 ± 20) N in accordance with A 40 of EN ISO 2439:2008 and being at least 400 mm × 800 mm in area but not larger than the mattress base of the playpen under test. The test mattress shall have a cotton cover with a mass per unit area of 100 g/m² to 120 g/m².

5 General

5.1 Product conditioning

Before testing, any fabrics used shall be cleaned or washed and dried twice in accordance with the manufacturer's instructions.

5.2 Test conditions

The tests shall be carried out in ambient conditions of 15 °C to 25 °C.

The tests are designed to be applied to playpens that are fully assembled and ready for use. If of a knock-down type, the playpen shall be assembled according to the manufacturer's instructions. If the playpen can be assembled or combined in different ways, the most onerous combinations shall be used for each test.

Knock-down fittings shall be tightened before testing. Further re-tightening shall not take place unless this is specifically required by the manufacturer.

5.3 Application of forces

The forces in the static load tests shall be applied sufficiently slowly to ensure that negligible dynamic force is applied.

The forces in durability tests shall be applied at a rate to ensure that excessive heating does not occur.

5.4 Tolerances

Unless otherwise stated, the following tolerances apply:

a) Forces: ± 5 % of the nominal force;

- b) Masses: $\pm 0,5$ % of the nominal mass;
- c) Dimensions: $\pm 1,0$ mm of the nominal dimension;
- d) Angles: $\pm 2^\circ$ of the nominal angle;
- e) Positioning of loading pads: ± 5 mm;
- f) Duration of forces:
 - 1) (2 ± 1) s for durability tests;
 - 2) (10 ± 2) s for static load tests.

The tests are described in terms of the application of forces. Masses can however be used. The relationship $10\text{ N} = 1\text{ kg}$ may be used for this purpose.

Unless otherwise specified, the test forces may be applied by any suitable device which does not adversely affect the results.

5.5 Prevention of movement of the playpen during testing

If the playpen tends to slide or roll during the tests specified in Clause 8, it shall be restrained by stops (4.15).

5.6 Order of tests

Unless otherwise stated the tests shall be carried out on the same playpen in the order listed in this standard.

6 Chemical hazards

See rationale in A.2.

The migration of synthetic or natural elements from coatings of paint, varnish, lacquer, polymer and similar coatings on exterior surfaces shall comply with the following amounts:

- a) Antimony: 60 mg/kg;
- b) Arsenic: 25 mg/kg;
- c) Barium: 1 000 mg/kg;
- d) Cadmium: 75 mg/kg;
- e) Chromium: 60 mg/kg;
- f) Lead: 90 mg/kg;
- g) Mercury: 60 mg/kg;
- h) Selenium: 500 mg/kg.

These limits shall be verified in accordance with the test method given in EN 71-3.

Where a surface is coated with a multi-layer of paint or similar coating, the test sample shall not include the base material.

A separate sample may be used for these tests.

The underside of the playpen base and any castors/wheels are excluded from these requirements.

7 Thermal hazards

When tested in accordance with EN 71-2, the maximum rate of spread of flame of textile materials or coated textile materials shall not exceed 30 mm/s. See rationale in A.3.1.

When tested in accordance with EN 1103, there shall be no flash effect. See rationale in A.3.2.

These requirements apply to parts with an area larger than 310 cm².

A separate sample may be used for these tests.

8 Mechanical hazards

8.1 Child retention function

8.1.1 General

See rationale in A.4.2.

8.1.2 Height of barrier

8.1.2.1 Requirements

With the base in its lowest position the minimum vertical distance between the upper surface of the playpen base and any part of the upper surface of the barrier shall be at least 600 mm when measured in accordance with 8.1.2.2.9.

With the base in its lowest position the minimum distance between any foothold and any part of the upper surface of the barrier (see Figure 16) shall be at least 600 mm when measured in accordance with 8.1.2.2.10.

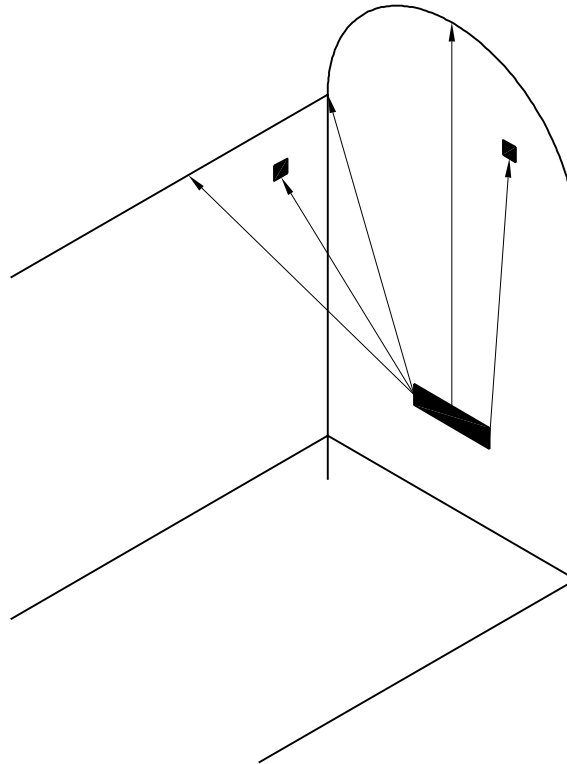

Figure 16 — Example of measurement between footholds and/or top of barriers with its base in its lowest position

With the base in its highest position the minimum vertical distance between the upper surface of the playpen base and any part of the upper surface of the barrier shall be at least 300 mm when measured in accordance with 8.1.2.2.9.

The rationale is given in A.4.2.2.

8.1.2.2 Determination of a foothold

8.1.2.2.1 Continuous structure

A foothold exists on a continuous structure if four triangles marked on the template are completely obscured by the structure being checked. These four triangles shall have at least one side in common with another of the triangles, see Figure 17.

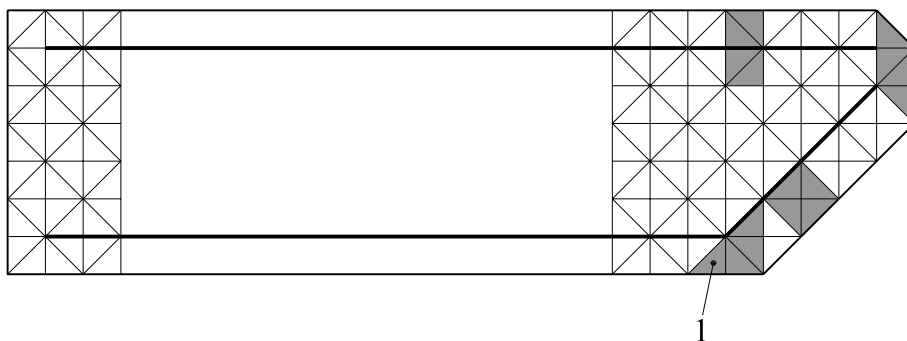

Key

- 1 This shaded area denotes one triangle; four shaded areas denotes four obscured triangles

Figure 17 — Examples of obscured triangles indicating a foothold on a continuous structure

8.1.2.2.2 Non-continuous structure

A foothold exists on a non-continuous structure if two or more triangles marked on the template are completely obscured between the edge of the template and the bold lines of the template by the structure being checked. The two or more triangles on either side of the template shall have at least one side in common with each other, see Figure 18.

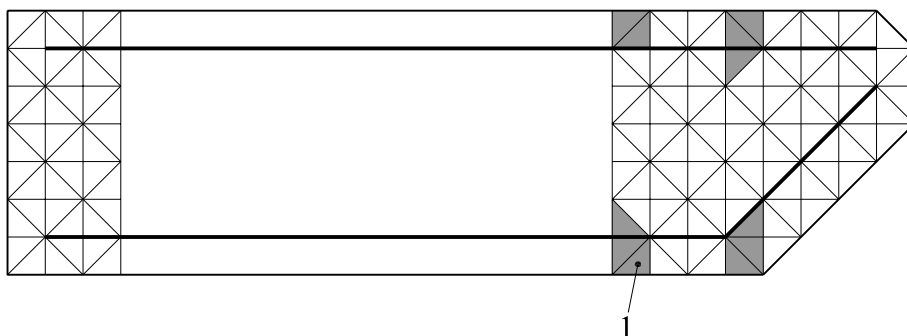

Key

- 1 This shaded area denotes one triangle

Figure 18 — Example of obscured triangles on a foothold on a non-continuous structure

8.1.2.2.3 Wire, thin structures and similar parts

A foothold exists on a wire, thin structure and similar part if it projects across the bold lines on the template, see Figure 19.

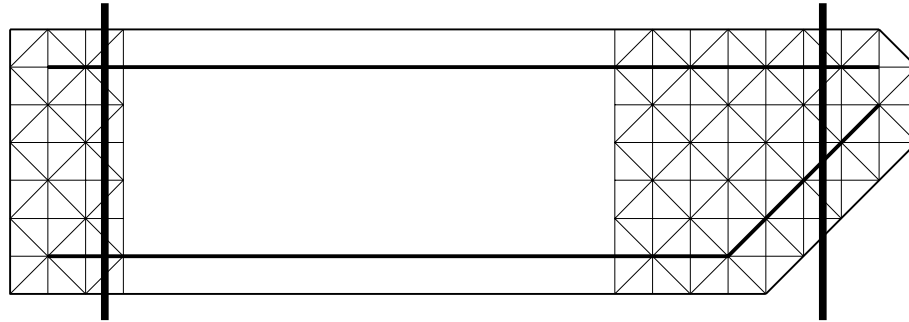

Key

| Denotes a wire, thin structure or similar part

Figure 19 — Example of a foothold on a wire, thin structure and similar part

8.1.2.2.4 Footholds on a continuous structure at an angle less than 55°

Using either the left or right hand template, place the template with its marked face on any continuous structure inclined at an angle of less than 55° to the horizontal. Orientate either template, see Figure 2, to check whether any four triangles are obscured indicating a foothold; see Figure 20 for examples.

8.1.2.2.5 Footholds on a non-continuous structure at an angle of less than 55°

Using either the left or right hand template, place the template with its marked face on any non-continuous structure inclined at an angle of less than 55° to the horizontal. Orientate either template, see Figure 2, to check whether two or more triangles are obscured between the edges of the template and the bold lines on the template indicating a foothold; see Figure 21 for examples.

8.1.2.2.6 Footholds on wire, thin structures or similar parts at an angle less than 55°

Using either the left or right hand template, place the template with its marked face on any wire, thin structure or similar parts at an angle less than 55° to the horizontal. Check whether the wire, thin structure or similar part has a line of contact extending between the two bold lines marked along the template; see Figure 22 for examples.

8.1.2.2.7 Footholds on an intersecting or adjacent structure where the second structure prevents slipping

Using either the left or right hand template, place the template with its marked face on any structure, thin structure or similar parts between 55° and 80° to the horizontal where there is also a supporting structure. Orientate either template, see Figure 2, to check whether any four triangles are obscured indicating a foothold; see Figure 23 for examples.

8.1.2.2.8 Footholds on rigid components covered by flexible materials

Where flexible materials or fabrics are covering rigid components, the template is pushed against the flexible material or fabric with a horizontal force of up to 30 N acting along the longitudinal axis of the template. Orientate either the left hand or the right hand template, see Figure 2, to check whether any four triangles are obscured by the rigid components indicating a foothold.

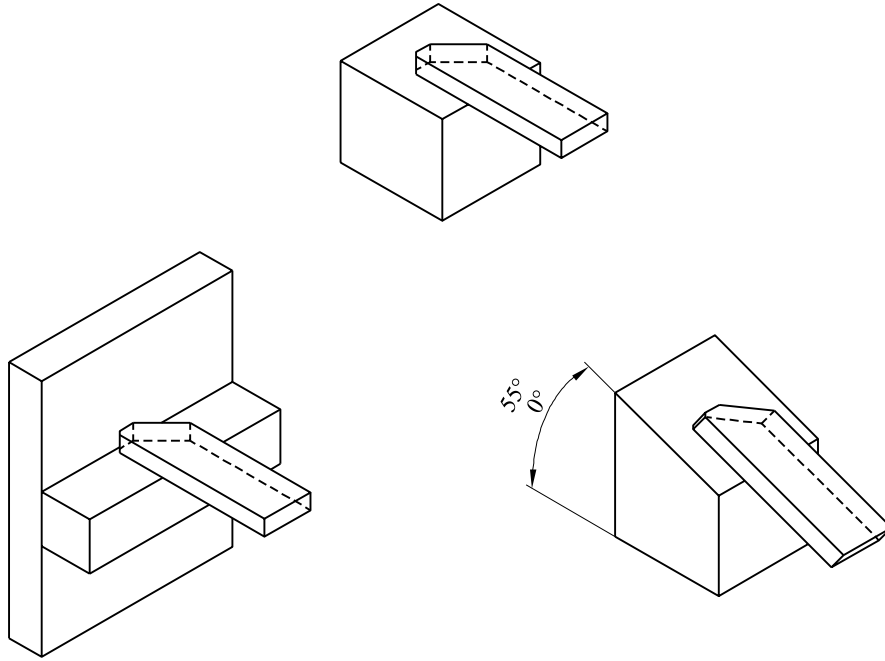

Figure 20 — Examples of footholds on a continuous structure at an angle less than 55°

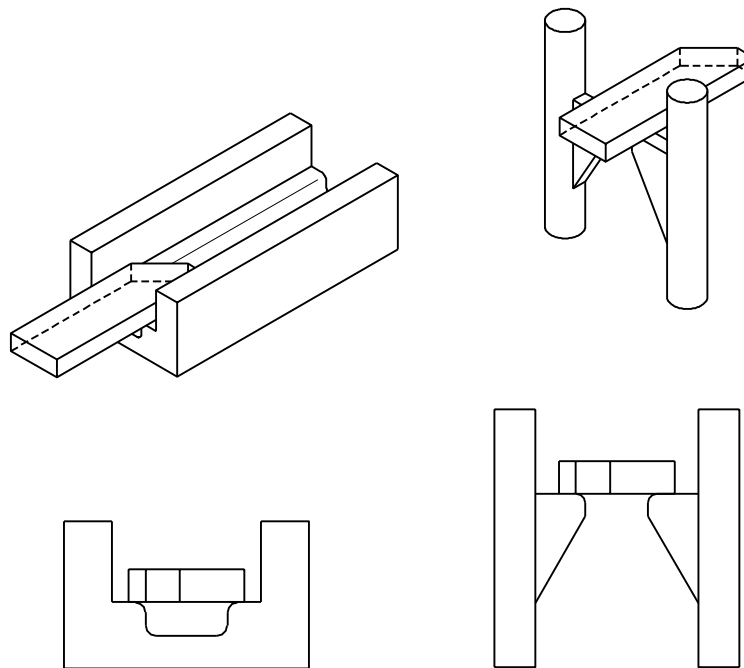

Figure 21 — Examples of footholds on a non-continuous structure at an angle less than 55°

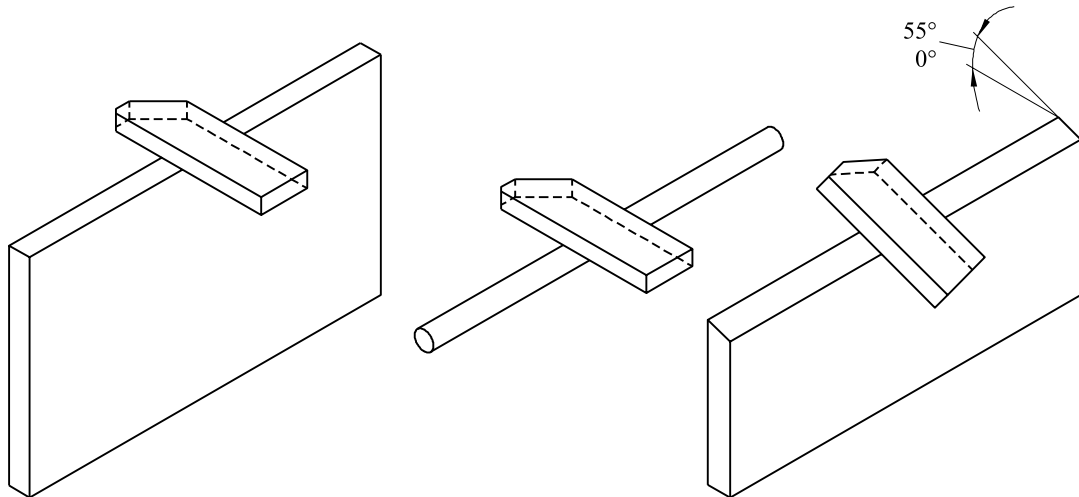

Figure 22 — Example of footholds on thin structures, on wire, or similar parts at an angle less than 55°

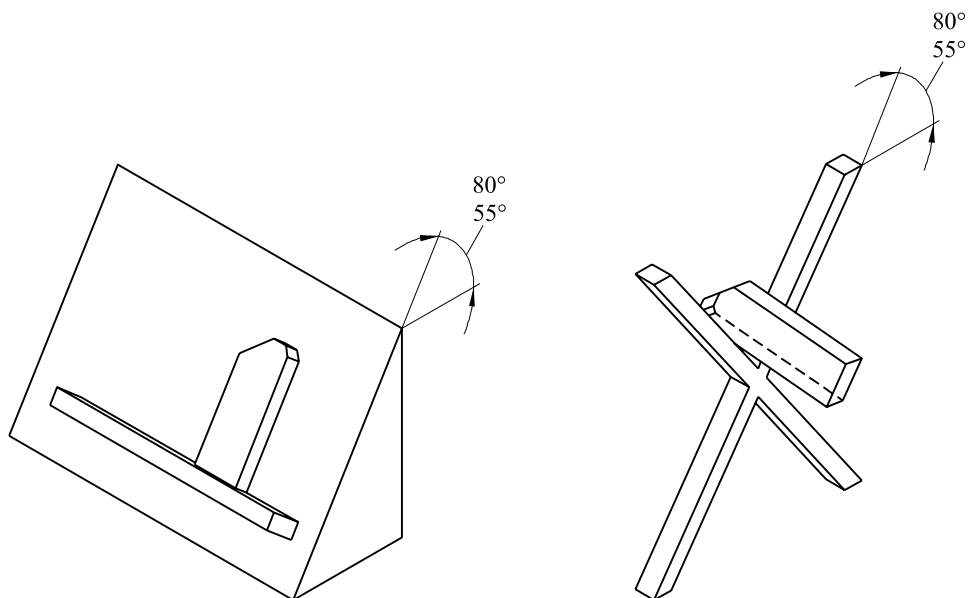

Figure 23 — Example of footholds on intersecting or adjacent structures where the second structure prevents slipping

8.1.2.2.9 Measurement of vertical height of barrier

Measure the vertical distance between the upper surface of the base, without applying any load to the base, and any part of the upper surface of the barrier. Apply a force of 300 N, positioned as described in 8.9.6.2, to the upper surface of the barrier and measure the height of the barrier under load.

8.1.2.2.10 Measurement between any foothold and the upper surface of barrier

Measure the distance between any foothold and any part of the upper surface of the barrier.

8.1.3 Size of openings

8.1.3.1 Requirements

When tested in accordance with 8.1.3.2, there shall be no openings that allow the hip probe to pass completely through when applied from the inside of the playpen.

See rationale in A.4.2.3.

8.1.3.2 Test method

Apply the hip probe, see 4.1, with a force in the longitudinal axis of the probe in any direction with a force up to 30 N into any opening accessible from inside the playpen.

8.1.4 Security of folding mechanisms

8.1.4.1 Requirements

To avoid the hazards due to unintentional release or operation by a child, one of the following conditions shall be fulfilled before and after testing in accordance with 8.1.4.2:

- a) all locking mechanisms require a minimum force of 50 N; or
- b) folding is only possible when two independent locking mechanisms are operated simultaneously; or
- c) there are two or more automatically engaging locking mechanisms that cannot be released by one single action; or
- d) folding of the playpen requires two consecutive actions, the first of which shall be maintained while the second is carried out, where the weight of the child acts to prevent folding, the removal of the child can be considered as one action; or
- e) have two locking mechanisms separated by a distance of at least 850 mm and requiring to be operated simultaneously.

Playpens that fold towards the inside shall be equipped with at least two locking mechanisms.

See rationale in A.4.2.4.

8.1.4.2 Test methods

With the playpen assembled for use in accordance with the manufacturer's instructions unfold and fold the playpen 300 times.

8.2 Requirements for castors/wheels

Castors/wheels shall not be fitted except in the following configuration, either:

- a) two or more castors/wheels and at least two other support points; or
- b) at least four castors/wheels, of which at least two can be locked.

8.3 Entrapment

8.3.1 General

The rationale is given in A.4.3.

8.3.2 Head entrapment

8.3.2.1 Requirements

When tested in accordance with 8.3.2.2.1, completely bound openings on the outside (exterior) of the playpen that allow the small head probe to pass completely through shall also allow the large head probe to pass completely through the bound opening.

Completely bound openings that allow the large head probe to pass completely through shall comply with the requirement for partially bound, V and irregular shaped openings when tested in accordance with 8.3.2.2.2.

Partially bound, V and irregular shaped openings shall be constructed so that:

- a) portion B of the template (see 4.4) does not enter the opening when tested in accordance with 8.3.2.2.2;
or
- b) the apex of portion A of the template contacts the base of the opening when tested in accordance with 8.3.2.2.2.

The following requirements do not apply to playpens that have mesh or fabric sides/ends and a rigid leg or support system, when the lowest part of the opening is less than 100 mm from the floor.

The area under the playpen base is excluded from these requirements.

8.3.2.2 Test methods

8.3.2.2.1 Completely bound openings

Press the small head probe specified in 4.3.1 with the highest force possible up to 30 N into completely bound openings. If the small head probe passes completely through the opening, then the large head probe specified in 4.3.2 shall pass completely through the completely bound opening with a force of up to 5 N. If completely bound openings contain V or irregular shaped openings, they should be assessed in accordance with 8.3.2.2.2.

8.3.2.2.2 Partially bound, V and irregular shaped openings

Position the B portion of the V and irregular shaped openings template specified in 4.4 between and perpendicular to the boundaries of the opening, as shown in Figure 24 or Figure 25 as appropriate. If the full thickness of the template cannot be inserted there is no hazard, but if it can be inserted there is a hazard, see Figures 24 and 25.

If the V and irregular shaped openings template can be inserted to a depth greater than the thickness of the template (45 mm), apply the A portion of the V and irregular shaped openings template, so that its centre line is in line with the centre line of the opening. Ensure that the plane of the test template is parallel and applied in line with the opening, as shown in Figure 26. Insert the V and irregular shaped openings template along the centre line of the opening until its motion is arrested by contact with the boundaries of the opening. If the V and irregular shaped openings template touches the bottom of the opening there is no hazard, but if the sides of the template touch the sides of the opening there is a hazard, see Figure 26.

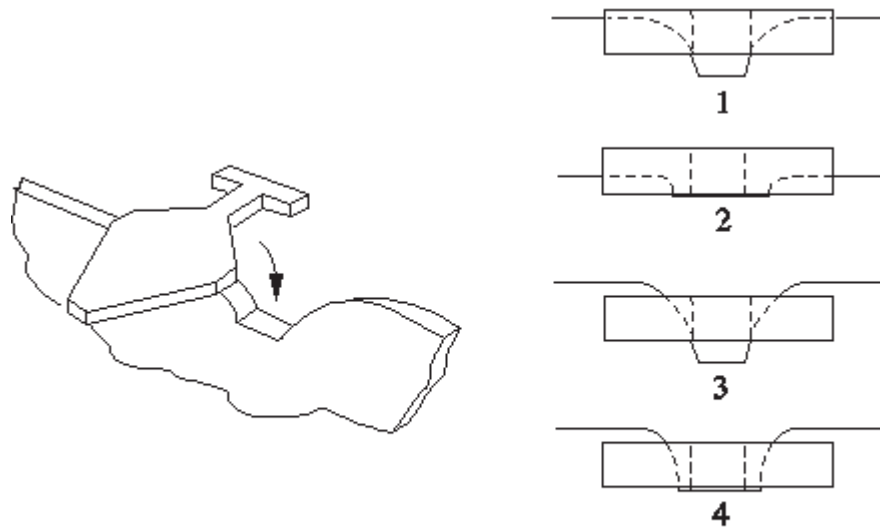

Key

- 1 is not a hazard
- 2 is not a hazard
- 3 is a hazard
- 4 is a hazard

Figure 24 — Method of insertion of portion B

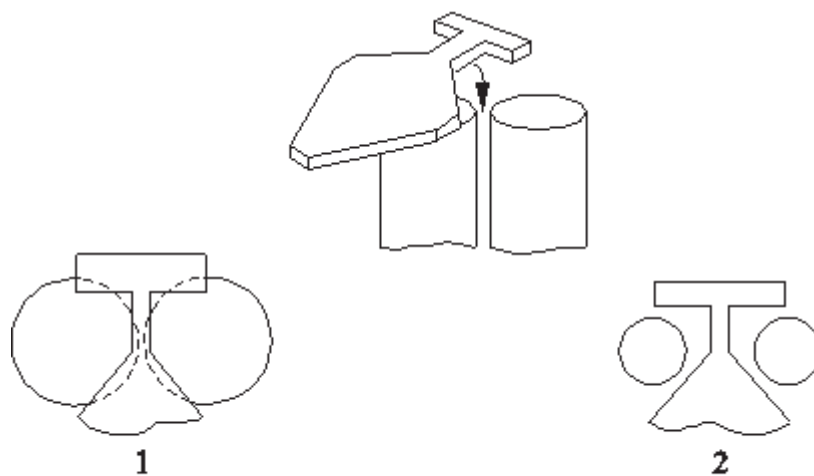

Key

- 1 is not a hazard
- 2 is a hazard

Figure 25 — Method of insertion of portion B

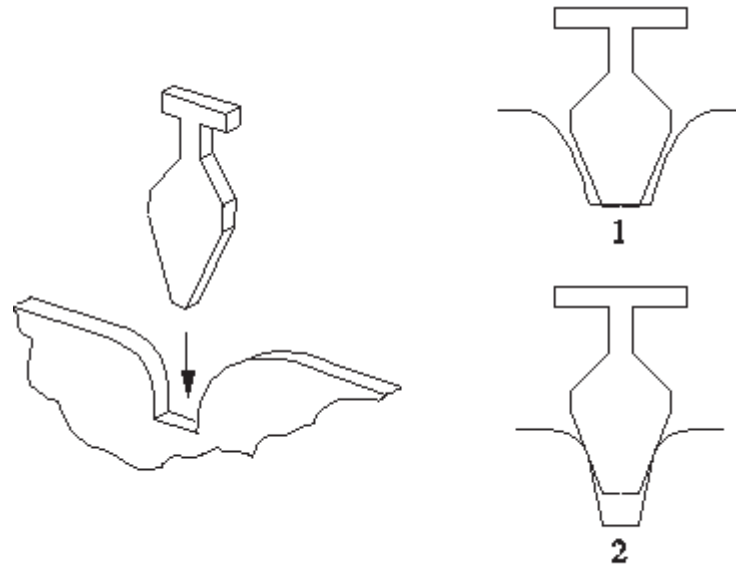

Key

- 1 is not a hazard
- 2 is a hazard

Figure 26 — Method of insertion of portion A

8.3.3 Finger entrapment

8.3.3.1 Requirements

There shall be no openings between 7 mm and 12 mm unless the depth of penetration is less than 10 mm when tested in accordance with 8.3.3.2.

Playpens that do not permit a child's hand to reach through the barrier shall have the exterior of the playpen, from 300 mm below the rim, excluded from this requirement.

Playpens that permit a child's hand to reach through the barrier shall have the underside of the base only excluded from this requirement.

There shall be no openings in mesh or flexible materials that allow the finger probe for mesh (Figure 7) to penetrate to the 7 mm diameter section.

The rationale is given in A.4.3.2.

8.3.3.2 Test method

Check whether the 7 mm probe (see Figure 6), with an applied force of up to 30 N, enters 10 mm or more into any accessible opening in any possible orientation. If the 7 mm probe enters 10 mm or more, then the 12 mm probe (see Figure 6) shall also enter 10 mm or more with an applied force of up to 5 N.

Check whether the finger probe for mesh (see Figure 7), with an applied force of up to 30 N, penetrates openings in mesh and flexible materials to the 7 mm diameter section.

8.4 Hazards from moving parts

8.4.1 Requirements for compression points

After the playpen is set up for normal use in accordance with the manufacturer's instruction, there shall be no accessible compression points which can close to less than 12 mm unless they are always less than 3 mm, as the result of

- a) the mass or movement of the playpen; or
- b) the movement of body weight by the child using the playpen; or
- c) the application of an external force (either by another child or, unintentionally, by the carer, or by a powered mechanism).

The rationale is given in A.4.4.

8.4.2 Requirements for shear points

After the playpen is set up for normal use in accordance with the manufacturer's instruction, there shall be no accessible shear points which can close to less than 12 mm, as the result of

- a) the mass or movement of the playpen; or
- b) the movement of body weight by the child using the playpen; or
- c) the application of an external force (either by another child or, unintentionally, by the carer, or by a powered mechanism).

8.4.3 Shear and compression points when setting up and folding

Shear and compression points that are created only when setting up or folding are permitted when there is no powered mechanism employed to fold the playpen.

When a powered mechanism is employed to fold the playpen there shall be no shear or compression points between 5 mm and 25 mm.

8.5 Entanglement

8.5.1 General

The rationale for entanglement is given in A.4.5.

8.5.2 Cords, ribbons and similar parts

8.5.2.1 Requirements

Cords, ribbons and similar parts that are accessible from inside the playpen shall have a maximum free length of 220 mm when tested in accordance with 8.5.2.2. Where cords, ribbons and similar parts are attached to the playpen together or within 80 mm of each other any single cord shall have a maximum free length of 220 mm and the combined length from one loose end to the end of another shall be a maximum of 360 mm.

Loops shall have a maximum peripheral dimension of 360 mm.

The rationale is given in A.4.5.2.

Monofilament threads shall not be used as cords, ribbons and similar parts, loops or as sewing threads.

The rationale is given in A.4.5.3.

8.5.2.2 Test method

The length of a cord, ribbon or similar part is measured from the fixing point on the article to the free end of the cord, ribbon or part used as a tie while a 25 N tensile force is applied.

The peripheral dimension of a loop shall be measured while a 25 N tensile force is applied.

8.5.3 Protruding parts

8.5.3.1 Requirements

When tested in accordance with 8.5.3.2, the ball chain loop and spherical mass shall not be supported by any protruding part accessible from inside the playpen. Parts of the playpen barrier more than 1 400 mm above the playpen base are considered not accessible.

The rationale is given in A.4.5.4.

8.5.3.2 Test methods

Place the base of the playpen in its lowest position.

Hold the spherical mass of the test equipment (see 4.6) in one hand and with the other hand create an open loop in the ball chain. Place the ball chain loop over any potential protruding part accessible from the inside of the playpen. Lower the weight until either the ball chain loop gets caught and the weight hangs freely from the protruding part, see Figure 27, or the ball chain loop slides over the protruding part.

Repeat the test for a total of three times. If during any of the three tests the loop and mass is supported by a protruding part, this is considered to be a failure.

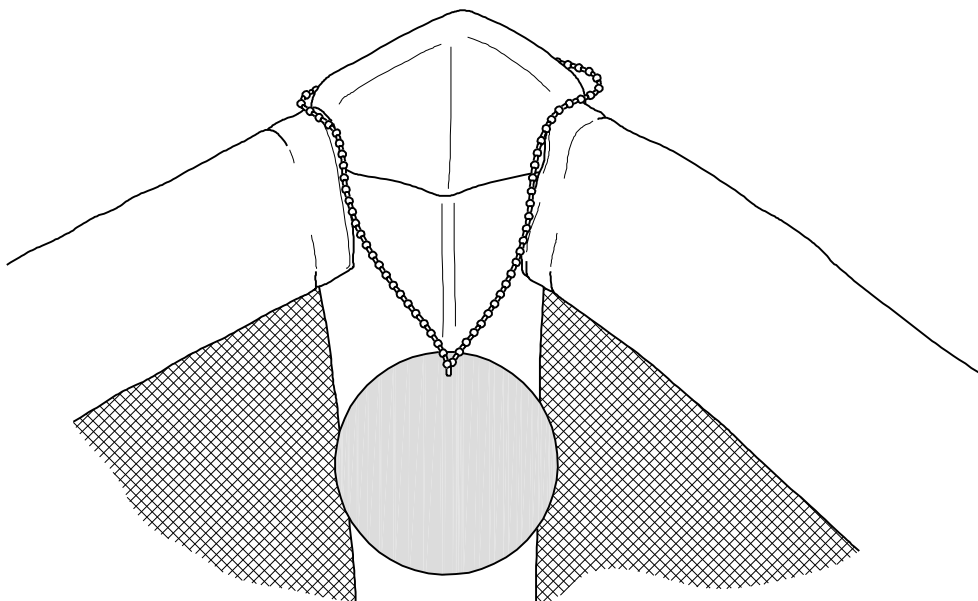

Figure 27 — Retention of loop and mass

8.6 Choking and ingestion hazards

8.6.1 Detachable components

8.6.1.1 General

The rationale is given in A.4.6.

8.6.1.2 Requirements

When tested in accordance with 8.6.1.3.1, 8.6.1.3.2 and 8.6.1.3.3 any component or part of a component that is removed, whether intended to be removed without the use of a tool or not, shall not fit entirely within the small parts cylinder specified in 4.7.

The rationale is given in A.4.6.2.

8.6.1.3 Test methods

8.6.1.3.1 Assessment of child's ability to grip components

A component is considered to be able to be gripped by a child if it can grip the component between its thumb and forefinger or between its teeth. Where it is difficult to assess whether a child can grip a component, it shall be possible to insert the feeler gauge specified in 4.8 for a least 2 mm using a force of (10 ± 1) N between the component and the underlying layer of the component or the playpen.

8.6.1.3.2 Torque test

Apply a torque gradually to the component within a period of 5 s in a clockwise direction until either

- a rotation of 180° from the original position has been attained; or
- a torque of 0,34 Nm is reached.

The maximum rotation or required torque shall be applied for 10 s.

The component shall then be allowed to return to a relaxed condition and the procedure repeated in an anticlockwise direction.

Where projections, components or assemblies are rigidly mounted on an accessible rod or shaft designed to rotate together with the projections, components or assemblies, during the test, the rod or shaft shall be clamped to prevent rotation.

If a component which is attached by a screw thread that becomes loosened during application of the required torque, the torque shall continue to be applied until the required torque is exceeded or the component disassembles or it becomes apparent that the component will not disassemble.

When using clamps and test equipment care shall be taken not to damage the attachment mechanism or body of the component.

Check whether any component or part of a component that is removed during the test fits wholly within the small parts cylinder specified in 4.7.

8.6.1.3.3 Tensile test

The tensile test shall be carried out on the same components as the torque test.

Attach a suitable clamp to the component assessed as being grippable in accordance with 8.6.1.3.1, taking care not to damage the attachment mechanism or body of the component.

Fasten the component in a tensile testing machine and apply a tensile force of up to 90 N to the component to be tested. Apply the force gradually within a period of 5 s and maintain for 10 s.

Check whether the component or any part of a component that is removed during the test fits wholly within the small parts cylinder specified in 4.7.

8.6.2 Playpen rim

8.6.2.1 Requirements

No filling shall be detached from the playpen rim when tested in accordance with 8.6.2.2.

The rationale is given in A.4.6.3.

8.6.2.2 Test method

The test procedure comprises two stages:

- Stage 1) Pinch the materials of the inside face of the playpen rim between finger and thumb and attach the bite tester, specified in 4.9 so as to "bite" the smallest amount of materials possible to allow contact with all four teeth and apply a pulling force of 50 N, maintaining it for 10 s, to the bite tester; then
- Stage 2) open the jaws of the bite tester as far as possible and push it horizontally onto the playpen rim as far as the guide, allow the teeth to close on the playpen rim and apply a pulling force of 50 N, maintaining it for 10 s to the bite tester.

This test procedure is applied to the following positions on the playpen rim:

- a) the centre of the longest straight edge;
- b) the centre of the longest radiused portion;
- c) the centre of the smallest radiused portion;
- d) any joint or seam;
- e) any other position considered more onerous.

If, during the test procedure, the outer material of the playpen rim is punctured by the teeth, remove the outer material to expose the layer below or the filling and repeat stages 1 and 2 until the filling cannot be reached or no filling becomes detached. As soon as any filling becomes detached the test is terminated.

A puncture is defined as occurring when at least one tooth of the bite tester has broken the textile or plastic material to which it is being applied, the tooth passing through the entire thickness of the material. Where the bite tester is applied to materials of a loose weave or open mesh, a puncture is defined as occurring when part of the weave or mesh is broken by at least one of the teeth of the bite tester. Should the teeth of the bite tester pass through materials of a loose weave or open mesh without damaging the material, a puncture has not occurred.

8.7 Suffocation hazards

8.7.1 Requirements for self adhesive labels and decals

Self adhesive labels and decals shall not be accessible to the child in the playpen, see 3.6.

The rationale is given in A.4.6.4.

8.7.2 Requirements for packaging

Any plastic covering used as packaging that does not fulfil the requirements of EN 71-1, shall be conspicuously marked in the official language(s) of the country where the playpen is sold with the following statement:

"TO AVOID DANGER OF SUFFOCATION REMOVE PLASTIC COVER BEFORE USING THIS ARTICLE. THIS COVER SHALL BE DESTROYED OR KEPT AWAY FROM CHILDREN"

NOTE The statement may be expressed in different words providing they clearly convey the same information.

The rationale is given in A.4.6.5.

8.8 Hazardous edges and projections

8.8.1 General

The rationale is given in A.4.7.

8.8.2 Edges

Edges and protruding parts accessible during normal use shall be rounded or chamfered and free of burrs and sharp edges.

The underside of the base of the playpen is excluded from this requirement.

Annex B shows examples for the design of safe edges and corners.

8.8.3 Requirements for points

There shall be no sharp points, e.g. staples, nails or screws, protruding from any part of the playpen.

8.9 Structural integrity

8.9.1 General

The rationale is given in A.4.8.

8.9.2 Grab handles

8.9.2.1 Requirements

When tested in accordance with 8.9.2.2 the grab handle shall not be damaged or become detached.

8.9.2.2 Test method

Gradually apply a vertically downwards force of 200 N to each grab handle and maintain for 1 min. All grab handles shall be tested independently.

8.9.3 Requirements for connecting screws

Connecting screws for direct fastening, e.g. self-tapping screws, shall not be used for the assembly of any component that is designed to be removed or loosened when dismantling the playpen for purposes of transportation or storage.

8.9.4 Requirements for staples

Staples shall be loaded in shear and shall not protrude above the surface.

8.9.5 Playpen base

8.9.5.1 Requirements

When tested in accordance with 8.9.5.2, no part of the playpen shall break, the base shall not become dislodged and the normal function of the playpen shall not be affected. When the playpen base is in contact with the floor, over its entire surface, the playpen is excluded from this requirement.

When tested in accordance with 8.9.5.2, the distance between the base and any barrier shall be a maximum of 5 mm.

If the base is adjustable, it shall not be possible to adjust it from a higher position to a lower position without the use of a tool unless the locking mechanisms fulfil the requirements of 8.1.4.

8.9.5.2 Test method

Place the playpen on a horizontal, rigid, flat surface.

Place the base in its lowest position. Place the test mattress (4.17) flat on the playpen base. Drop the base impactor specified in 4.10 allowing it to fall freely 1 000 times at a rate of not more than 30 times per minute, through a distance of (150 ± 5) mm above the playpen base onto the test mattress at each of the selected positions of impact, see Figure 28.

The impactor shall fall freely and bouncing shall not be restricted.

When the height of the base is adjustable and if the support construction is not the same as in the lowest position, repeat the test with the base at its highest position, on a point near to an attachment point.

The impact test shall be conducted at the impact points defined in Figure 28.

The maximum horizontal distance between the side of the impactor and the inner surface of the barrier shall be 50 mm at points b, c and d, see Figure 28.

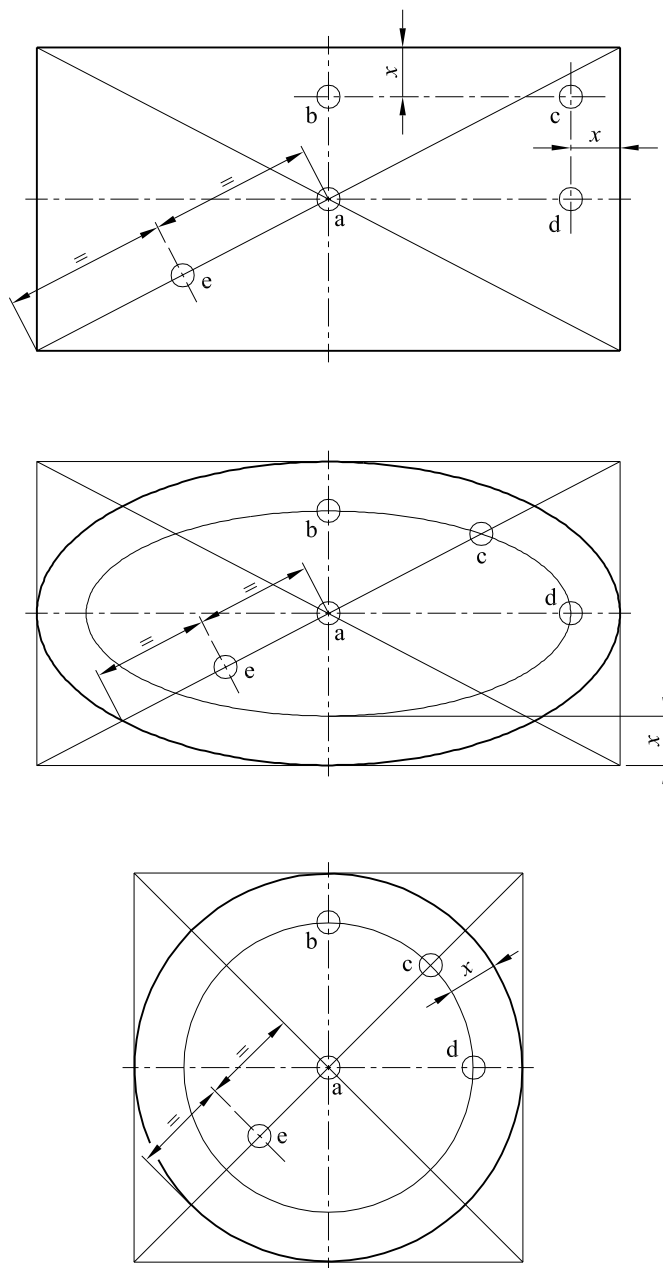

Key

$X > 125 \text{ mm}$ and $\leq 175 \text{ mm}$

a, b, c, d and e impact points

Figure 28 — Impact points

8.9.6 Strength of sides

8.9.6.1 Requirements for strength of sides

When tested in accordance with 8.9.6.2.1, 8.9.6.2.2 and 8.9.6.2.3, rigid sided playpens shall neither break nor become detached from their fastenings and shall not fold. Fittings and fastening devices shall not be damaged or detached and shall continue to function as intended.

When tested in accordance with 8.9.6.2.2, 8.9.6.2.3 and 8.9.6.2.4, there shall be no break, crevice or loosening of seams in mesh or fabric sided playpens and the playpen shall not fold. Fittings and fastening devices shall not be damaged or detached and shall continue to function as intended.

8.9.6.2 Test methods

8.9.6.2.1 Bending test

Position the playpen on a horizontal, rigid, flat surface with all the legs secured against stops specified in 4.15 and with the base at its lowest position. Prevent the playpen from tilting.

Apply a force of 250 N in turn to one side slat positioned in the middle and one at the end of each side. The force shall act horizontally in the directions of the longitudinal and transverse axis of the playpen. It shall be applied midway between the top and the bottom of the slat. The load duration shall be 30 s.

8.9.6.2.2 Impact test – sides

Position the playpen on a horizontal, rigid, flat surface with all the legs secured against stops specified in 4.15 and with the base at its lowest position. Prevent the playpen from tilting.

Place the side impacter (4.11) so that the impact acts on the side slat or side, at a height of 200 mm below the top edge of the side, see Figure 29.

One slat shall be hit from the outside, the next from the inside, and so forth. Carry out the test first from the outside and subsequently from the inside.

Playpens with a solid side shall have ten evenly distributed impacts on the longer sides and four evenly distributed impacts on the shorter sides, with the direction of impact alternating from inside and outside of the playpen. When all sides are the same length two opposite sides shall receive the ten impacts and the other two opposite sides shall receive the four impacts.

When testing playpens with mesh or fabric sides, the impacts shall act on ten points considered being the most onerous on the frame and/or support structure. Half of the points shall be impacted from the inside and half from the outside.

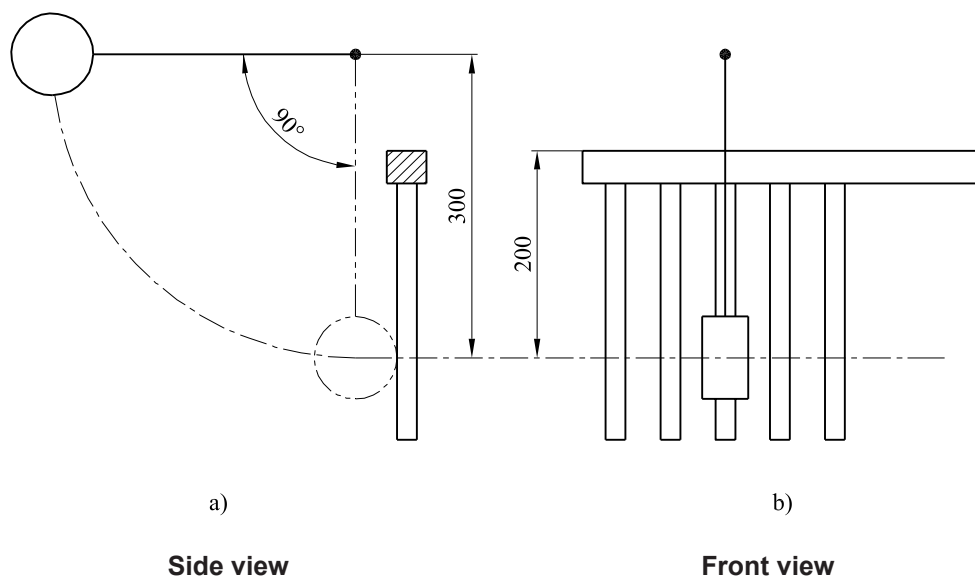

Figure 29 — Impact test – sides

8.9.6.2.3 Impact test – rim/top rail

Position the impact hammer to hit the rim/top rail as close to any corner post or joint as possible, see Figure 30. Allow the impact hammer to swing freely from an angle of 60° from the vertical. Carry out this procedure at either side of each corner post or joint of the playpen rim/top rail, making five impacts from inside the playpen and five impacts from outside the playpen at each position. When all the corner posts or joints around the rim/top rail are of the same construction only one needs to be tested. All different constructions need to be tested.

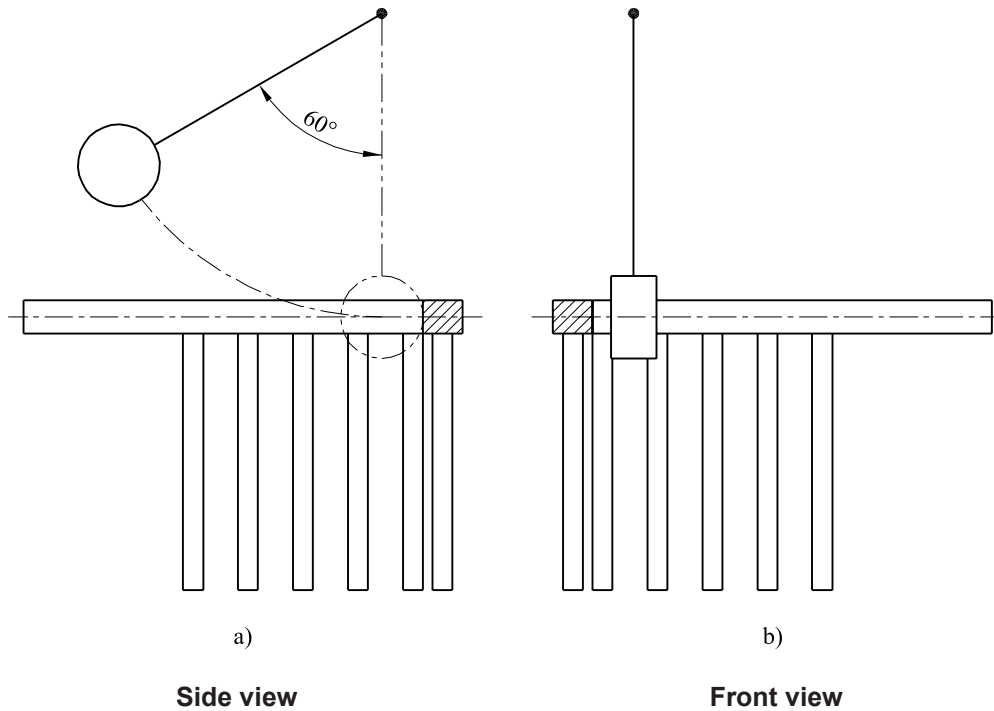

Figure 30 — Impact test – rim/top rail

8.9.6.2.4 Strength of mesh/fabric sides

Position the retaining blocks, see 4.13, and suitable leg supports on a hard flat horizontal surface. The retaining blocks shall be positioned parallel and with a distance of 400 mm between them.

Support the playpen on its side on the retaining blocks and leg supports so that the playpen is essentially horizontal. The playpen shall then be positioned so that the most onerous construction is tested.

Place the loading pad, see 4.12, on the inside mesh/fabric side on an axis centrally between the two retaining blocks and halfway between the top and bottom of the playpen side.

Gradually apply a total force of 250 N through the loading pad to the mesh/fabric side.

Throughout the test the free movement of the mesh/fabric shall not be restricted.

Repeat the test three times at the same point.

The test shall be repeated on any different construction.

8.9.7 Vertical static strength of frame and fastenings

8.9.7.1 Requirement

When tested in accordance with 8.9.7.2, there shall be no damage, the playpen shall not fold and shall continue to function as intended.

8.9.7.2 Test method

Position the playpen on a horizontal, rigid, flat surface with all the legs secured against stops specified in 4.15 and with the base at its lowest position. Prevent the playpen from tilting.

Gradually apply a vertical downwards force of 300 N and maintain for 10 s. The force shall be applied ten times at one position on the playpen rim considered to be the most onerous.

8.9.8 Fatigue strength

8.9.8.1 Requirement

When tested in accordance with 8.9.8.2 the fittings and fastening devices shall not be damaged or detached and the playpen shall continue to function as intended.

8.9.8.2 Test method

Position the playpen on a horizontal, rigid, flat surface with all the legs secured against the stops specified in 4.15.

Position the test load of 20 kg (4.14.2) at the centre of the bottom of the playpen.

A horizontal force of 100 N shall be applied in sequence to four points around the playpen rim, A, B, C and D. The force shall be applied by means of the loading pads, see 4.12, using a device that can apply the force sequentially in both longitudinal and lateral directions. The force shall be applied in opposite directions in both the longitudinal and lateral directions from the outside of the playpen, see Figure 31. Each application of the force shall take not less than 1 s to increase from 0 N to 100 N and back to 0 N.

The sequence shall be repeated 4 000 times.

The points for applying the forces (A, B, C, D) shall be located 50 mm from the intersection point of the centrelines of the side members at the highest point at that position, see Figure 31.

Dimensions in millimetres

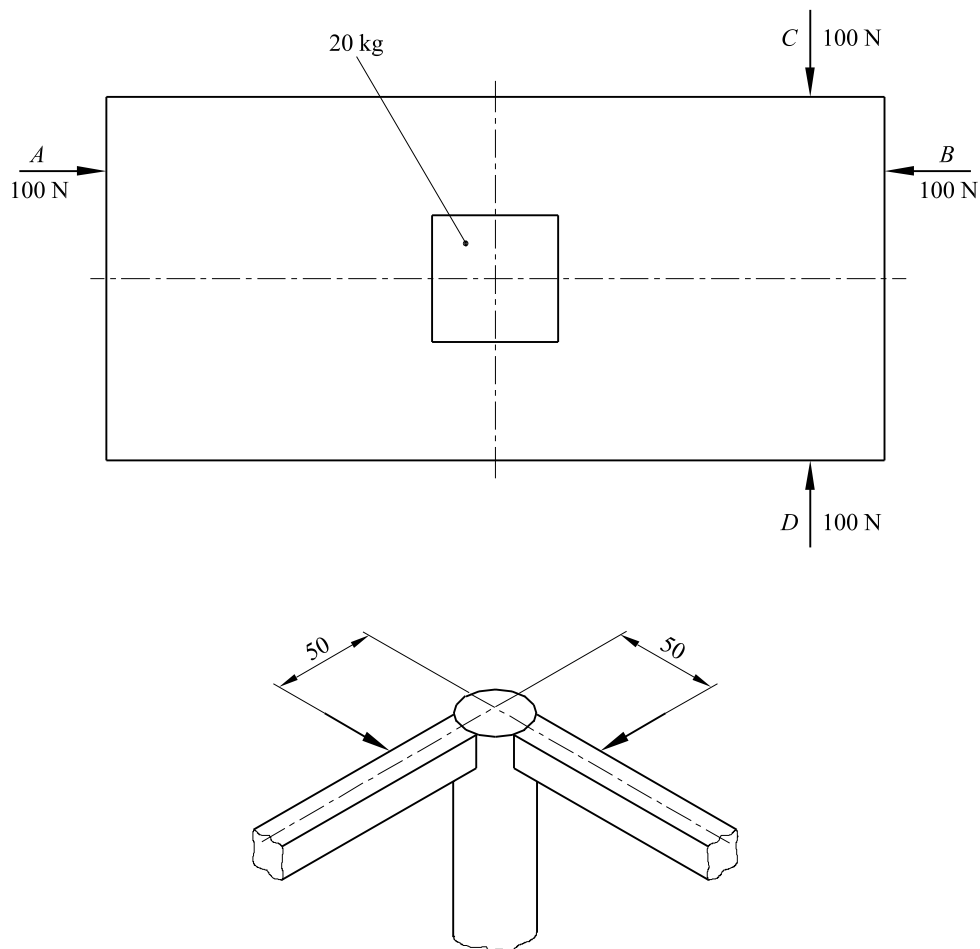

Key

A, B, C, D Points for applying the forces

Figure 31 — Fatigue test

8.10 Stability

8.10.1 Requirements

When tested in accordance with 8.10.2 the playpen shall not overturn.

The rationale is given in A.4.9.

8.10.2 Test method

Position the playpen on a horizontal, rigid, flat surface with the legs against the stops specified in 4.15. The tilting tendencies shall not be restrained.

In the case of playpens with castors/wheels, place the castors/wheels in the most onerous position.

Apply a mass of 10 kg with its centre of gravity at a point 50 mm downwards and 15 mm inwards measured from the upper surface of the rim of the playpen. Then apply a horizontally outwards force of 30 N to the top of the playpen rim in the position most likely to cause the playpen to overturn.

9 Product information

9.1 General

All product information required by this standard shall be given in the official language(s) of the country in which the playpen is sold.

Warning sentences shall have the word "WARNING" written in upper case.

9.2 Marking

9.2.1 Requirements

Playpens that conform to this standard shall be permanently marked with the following:

- a) the number and date of this European Standard;
- b) the name or trademark or other means of identification of either the manufacturer, distributor, importer or retailer.

Markings shall be conspicuous and legible and labels shall be securely attached.

9.2.2 Durability of marking

9.2.2.1 Requirement

After testing in accordance with 9.2.2.2 any permanent label and/or marking shall not be removed and markings shall be legible.

9.2.2.2 Test method

Any permanent label and/or marking shall be manually rubbed for 20 s using a water damped cotton cloth.

9.3 Purchase information

The following information shall be provided at the point of sale:

- the maximum age of the child for which the playpen is intended.

9.4 Instructions for use

9.4.1 General

Instructions for the safe use of the playpen shall be provided and shall be headed "**IMPORTANT! KEEP FOR FUTURE REFERENCE**" in letters not less than 3 mm high.

9.4.2 WARNINGS

The instructions shall contain the following warnings:

WARNING — Do not place the playpen close to an open fire or other heat source.

WARNING — Do not use the playpen without the base.

The following warning is only applicable for folding playpens:

WARNING — Ensure that the playpen is fully erected and all the locking mechanisms engaged before placing your child in this playpen.

9.4.3 Additional information

The instructions shall contain the following additional information, which may be presented with different wording:

- a) number and date of this European Standard;
- b) registered trade name or trademark of the manufacturer, distributor, importer or retailer;
- c) means of identifying the product, e.g. model number;
- d) maximum age of child for which the playpen is intended;
- e) if the height of the base is adjustable, the base should always be used in the lowest position as soon as the child is old enough to sit, kneel or to pull itself up;
- f) if applicable an assembly drawing, list and description of all parts and tools required for assembly and a diagram of the bolts and other fastenings required;
- g) statement drawing the attention of the user to the risk of leaving anything in the playpen which could provide a foothold or create a danger of suffocation or strangulation;
- h) statement that all assembly fittings should always be tightened properly;
- i) statement not to use the playpen if any part is broken, torn or missing and use only spare parts approved by the manufacturer;
- j) statement that accessories which are not approved by the manufacturer shall not be used;
- k) cleaning and maintenance recommendations.

10 Test report

The test report shall include at least the following information:

- a) reference to this European Standard;
- b) unit tested (relevant data);
- c) description of the delivery condition of the unit;
- d) test results in accordance with Clauses 6, 7 and 8;
- e) conformance to requirements;
- f) name and address of the test facility;
- g) date of the test.

Annex A (informative)

Rationales for inclusion of requirements for domestic playpens

A.1 General

This informative annex has been included with the purpose of providing the rationales for the inclusion of the requirements given in this standard.

A playpen is designed to provide an environment which restricts a child's access to hazards. It is essential therefore that the playpen should provide an effective protective function. Additionally, the playpen should be designed so that it cannot cause harm to the child.

Where appropriate, relevant clause numbers in the standard are given in this annex and the relevant reference for the annex is given in the normative part of the standard.

Attention is drawn to national and European legislations and regulations which have to be considered when addressing the safety of playpens.

A.2 Chemical hazards

Children up to the age of 24 months spend a considerable amount of time both mouthing and chewing. It is important that the level of the heavy metals used in the paints, varnishes, etc. which may have a harmful effect if ingested by the child are at a very low level. The test methods for these heavy metals are those specified in EN 71-3.

A.3 Thermal hazards

A.3.1 Flammability

It is necessary to reduce the rate of spread of flame as low as is reasonably possible so that a child can be removed if any of the materials used in the manufacture of the playpen should ignite.

The requirements and test method for the flammability of the materials used in playpens are those specified in EN 71-2.

A.3.2 Flash effect

Flash effect, where the flame spreads across the surface of material without the substrate burning, should also be controlled. The requirements and test method are those specified in EN 1103.

A.4 Mechanical hazards

A.4.1 General

There is a wide range of mechanical hazards from which a child requires protection. Reference can be made to CEN/TR 13387 for additional details concerning these hazards.

A.4.2 Child retention function

A.4.2.1 General

The child's access to hazards is limited by means of a protective barrier surrounding the child. The playpen should therefore be constructed so that the child cannot "escape" through the barrier, climb over the barrier or crawl under the barrier.

A base for the playpen is required so that the child cannot move the entire playpen or lift any part of the barrier to crawl underneath.

A.4.2.2 Height of barrier and footholds

The requirement for the minimum height of the barrier is given in 8.1.2.1. This barrier should not contain footholds that would enable a child to climb. Requirements for footholds are given in 8.1.2.1. If grab handles which can help a child to a standing position are fitted to the barrier, they should be placed at a sufficiently high level so that a child cannot easily gain a foothold.

A.4.2.3 Openings in the barrier

If the barrier comprises slats, they should be spaced so that the child's body and head cannot pass between them. However, if the child's torso could pass between the slats but not its head, there is the potential for the child's neck to be trapped, its air supply would then be restricted and brain damage could result. A requirement for a gap that would not let a hip probe to pass through is given in 8.1.3.1. It should be noted that the hip probe is applied from the inside to the outside of the playpen.

A.4.2.4 Security of folding mechanisms

Where a folding playpen is locked into position, if it should unfold in use, the child would be able to "escape", however the greater hazard would be that of crushing the child and this hazard has been addressed in hazards from moving parts.

Requirements are given in 8.3.2.

It only applies to the locking of mechanisms used to fold the playpen, not for the folding/unfolding of accessory. Accessory are not dealt within this standard.

A.4.3 Entrapment hazards

Entrapment hazards are where a child can become trapped in a static gap and the child does not have the ability to extract itself. These hazards should not be confused with those gaps between moving parts where a child's finger or flesh could become crushed or severed.

Entrapment of a child's head and neck is a serious hazard, its fingers less so and its limbs feet and hands although they would cause bruising and distress to the child, are considered to be the least serious.

It was considered not to be possible to design a playpen where all hazards gaps are addressed. Requirements have been included for the more serious hazards of head, neck and finger entrapment.

A.4.3.1 Head and neck entrapment

8.3.2.1 gives requirements to prevent a child's head becoming trapped. The head probe is applied from the outside to the inside of the playpen. This is particularly relevant to playpens with fabric or mesh sides where the fabric or mesh is usually backed by a support structure which could present hazards for trapping a child's head. 8.3.2.2 gives requirements for the elimination of gaps where a child's neck could become trapped.

A.4.3.2 Finger entrapment

8.3.3.1 gives requirements to reduce gaps where a child's fingers could become trapped.

A.4.4 Hazards from moving parts

8.4.1 gives requirements to reduce shear and squeeze points where a child's finger or flesh could be injured or severed. Unlike finger traps where a 7 mm gap is permitted, for moving parts a 3 mm gap is specified to reduce the risk of the flesh on a child's finger being severed.

As previously stated, requirements to prevent inadvertent folding of the entire product where a child's entire body could be crushed have been included.

A.4.5 Entanglement

A.4.5.1 General

If a child can become entangled within the playpen, there is a risk of strangulation.

A.4.5.2 Cords and loops

If a child can get a length or loop of cord, etc. wrapped around its neck, its airways could become restricted and brain damage could result. Any cords, strings or other narrow fabrics used on the playpen have their length restricted, see 8.5.2.1. The size of loops is also restricted to prevent them passing over the child's head, see 8.5.2.1.

A.4.5.3 Monofilament threads

Monofilament threads are made of a single thread from man-made fibre and are exceptionally strong. If they become wound round a child's finger the blood supply could be cut-off. There is a requirement in 8.5.2.1 that this type of thread should not be used in the manufacture of a playpen.

A.4.5.4 Protruding parts

Hazards associated with protruding parts can occur if a child's clothing can involuntarily become caught on projections or trapped in the playpen. The requirements given in 8.5.3.1 are to reduce the shape and size of projections and gaps.

A.4.6 Detachable components

A.4.6.1 General

Detachable components can be the cause of serious choking and suffocation hazards which occur when a child's internal or external airways are blocked, its breathing is impeded so that air cannot pass into the lungs.

Ingestion hazards result from small components passing into the child's stomach which may cause toxic contamination or internal blockage.

A.4.6.2 Size of components

The requirements given in 8.6.1.2 limit the size of components on the playpen that are either detachable or could be pulled off by the child. The requirements for both choking and ingestion hazards are identical.

A.4.6.3 Padded rims

Where a playpen has a padded rim, it is likely that the child will mouth, chew and bite on it. The requirements in 8.6.2.1 are to reduce the possibility of the child getting access to the filling which could cause a choking hazard.

A.4.6.4 Self-adhesive labels and decals

There is a requirement in 8.7.1 that self adhesive labels and decals shall not be used in playpens. This is to avoid the hazard of ingestion and suffocation from this plastic material moulding over the child's nose and mouth thus blocking the airways.

A.4.6.5 Packaging

To avoid the hazard of suffocation, packaging supplied with the playpen should be removed so that a child cannot gain access to it. 8.7.2 gives the text for a suitable warning.

A.4.7 Hazardous edges and projections

Sharp edges on the playpen could cause cuts, lacerations or abrasions to a child's skin, projecting parts could puncture a child's skin or eye. A corner is considered to be both a sharp edge and a projection.

Requirements to eliminate sharp edges and projections are given in 8.8.2 and 8.8.3.

A.4.8 Structural integrity

Any major failure of the structure of the playpen could either cause harm to the child or reduce its protective function.

8.9 gives requirements and test methods for both separate parts of the playpen and for aspects of the overall strength of the playpen.

A.4.9 Stability

It is also important that the playpen will remain stable and not tip over in use. Requirements which address the most onerous situation where a child is hanging by its arms on the side of a playpen are given in 8.10.1.

Annex B (informative)

Examples for the design of safe edges and corners

Figure B.1 shows examples for the design of safe edges and corners.

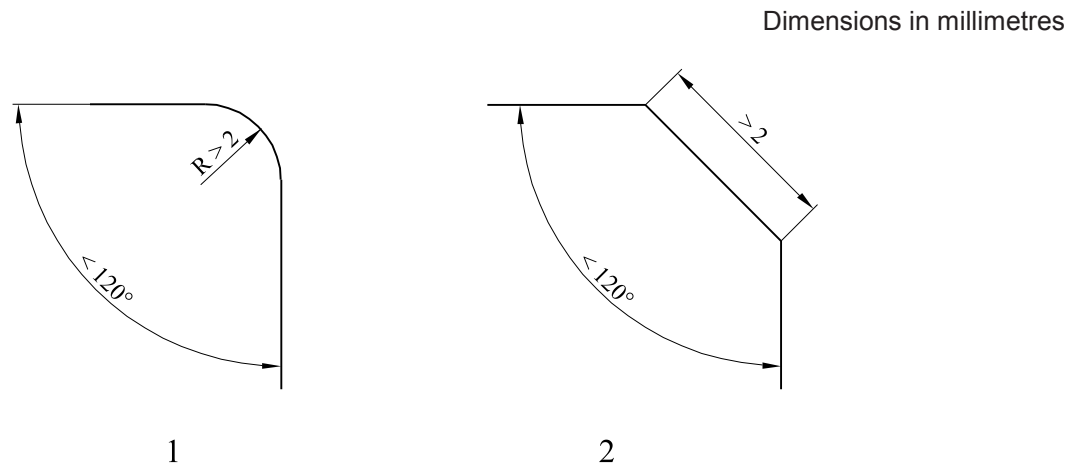

Key

- 1 Radiused
- 2 Chamfered

Figure B.1 — Examples of a safe design of edges and corners

Edges and corners on components with a thickness of less than 4 mm should be rounded, folded, rolled or spiralled as shown in the examples in Figure B.1 or have a protective covering as shown in the example in Figure B.2.

Where a component is folded, rolled or spiralled as shown in Figure B.1, the edge that is folded, rolled or spiralled should have full radius on it to reduce the hazard of sharp edges.

When tested in accordance with 8.6.1.3.3, the protective covering should either not be removed or if removed the edge should comply with the above or the examples given in Figure B.1.

Dimensions in millimetres

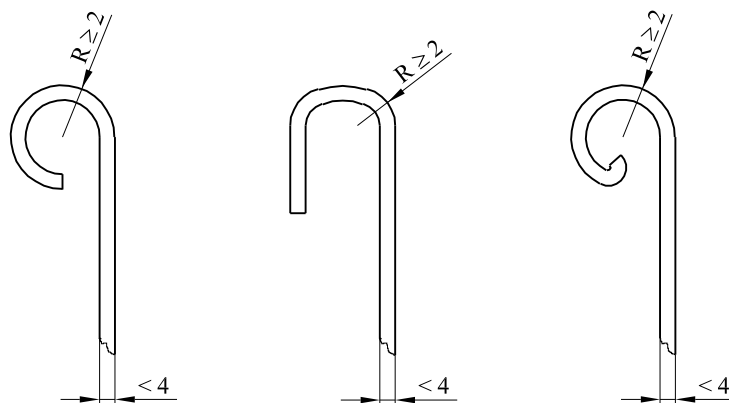

Figure B.2 — Examples of folded, rolled and spiralled edges

Dimensions in millimetres

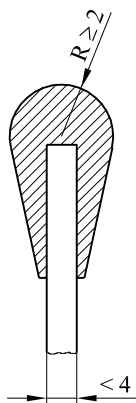

Figure B.3 — Example of a protected edge

When the playpen is assembled for use, any accessible external and internal edges on open-ended tubes should have a minimum radius of 2 mm or be chamfered as shown in Figure B.1.

Open-ended tubes with a wall thickness of less than 4 mm should all be closed, covered or capped.

Bibliography

- [1] CEN/TR 13387, *Child use and care articles — Safety guidelines*

British Standards Institution (BSI)

BSI is the national body responsible for preparing British Standards and other standards-related publications, information and services.

BSI is incorporated by Royal Charter. British Standards and other standardization products are published by BSI Standards Limited.

About us

We bring together business, industry, government, consumers, innovators and others to shape their combined experience and expertise into standards-based solutions.

The knowledge embodied in our standards has been carefully assembled in a dependable format and refined through our open consultation process. Organizations of all sizes and across all sectors choose standards to help them achieve their goals.

Information on standards

We can provide you with the knowledge that your organization needs to succeed. Find out more about British Standards by visiting our website at bsigroup.com/standards or contacting our Customer Services team or Knowledge Centre.

Buying standards

You can buy and download PDF versions of BSI publications, including British and adopted European and international standards, through our website at bsigroup.com/shop, where hard copies can also be purchased.

If you need international and foreign standards from other Standards Development Organizations, hard copies can be ordered from our Customer Services team.

Subscriptions

Our range of subscription services are designed to make using standards easier for you. For further information on our subscription products go to bsigroup.com/subscriptions.

With **British Standards Online (BSOL)** you'll have instant access to over 55,000 British and adopted European and international standards from your desktop. It's available 24/7 and is refreshed daily so you'll always be up to date.

You can keep in touch with standards developments and receive substantial discounts on the purchase price of standards, both in single copy and subscription format, by becoming a **BSI Subscribing Member**.

PLUS is an updating service exclusive to BSI Subscribing Members. You will automatically receive the latest hard copy of your standards when they're revised or replaced.

To find out more about becoming a BSI Subscribing Member and the benefits of membership, please visit bsigroup.com/shop.

With a **Multi-User Network Licence (MUNL)** you are able to host standards publications on your intranet. Licences can cover as few or as many users as you wish. With updates supplied as soon as they're available, you can be sure your documentation is current. For further information, email bsmusales@bsigroup.com.

BSI Group Headquarters

389 Chiswick High Road London W4 4AL UK

Revisions

Our British Standards and other publications are updated by amendment or revision.

We continually improve the quality of our products and services to benefit your business. If you find an inaccuracy or ambiguity within a British Standard or other BSI publication please inform the Knowledge Centre.

Copyright

All the data, software and documentation set out in all British Standards and other BSI publications are the property of and copyrighted by BSI, or some person or entity that owns copyright in the information used (such as the international standardization bodies) and has formally licensed such information to BSI for commercial publication and use. Except as permitted under the Copyright, Designs and Patents Act 1988 no extract may be reproduced, stored in a retrieval system or transmitted in any form or by any means – electronic, photocopying, recording or otherwise – without prior written permission from BSI. Details and advice can be obtained from the Copyright & Licensing Department.

Useful Contacts:

Customer Services

Tel: +44 845 086 9001

Email (orders): orders@bsigroup.com

Email (enquiries): cservices@bsigroup.com

Subscriptions

Tel: +44 845 086 9001

Email: subscriptions@bsigroup.com

Knowledge Centre

Tel: +44 20 8996 7004

Email: knowledgecentre@bsigroup.com

Copyright & Licensing

Tel: +44 20 8996 7070

Email: copyright@bsigroup.com



...making excellence a habit.™