

Gravity drainage systems inside buildings —

Part 4: Wastewater lifting plants — Layout and calculation

The European Standard EN 12056-4:2000 has the status of a
British Standard

ICS 91.140.80

National foreword

This British Standard is the official English language version of EN 12056-4:2000.

The UK participation in its preparation was entrusted by Technical Committee B/505, Wastewater engineering, to Subcommittee B/505/21, Roof drainage and sanitary pipework, which has the responsibility to:

- aid enquirers to understand the text;
- present to the responsible European committee any enquiries on the interpretation, or proposals for change, and keep the UK interests informed;
- monitor related international and European developments and promulgate them in the UK.

A list of organizations represented on this subcommittee can be obtained on request to its secretary.

Cross-references

The British Standards which implement international or European publications referred to in this document may be found in the BSI Standards Catalogue under the section entitled “International Standards Correspondence Index”, or by using the “Find” facility of the BSI Standards Electronic Catalogue.

A British Standard does not purport to include all the necessary provisions of a contract. Users of British Standards are responsible for their correct application.

Compliance with a British Standard does not of itself confer immunity from legal obligations.

Summary of pages

This document comprises a front cover, an inside front cover, the EN title page, pages 2 to 19 and a back cover.

The BSI copyright notice displayed in this document indicates when the document was last issued.

Amendments issued since publication

Amd. No.	Date	Comments

This British Standard, having been prepared under the direction of the Sector Committee for Building and Civil Engineering, was published under the authority of the Standards Committee and comes into effect on 15 September 2000

© BSI 09-2000

ISBN 0 580 36442 9

EUROPEAN STANDARD

EN 12056-4

NORME EUROPÉENNE

EUROPÄISCHE NORM

June 2000

ICS 91.140.80

English version

Gravity drainage systems inside buildings - Part 4: Wastewater lifting plants - Layout and calculation

Réseaux d'évacuation gravitaire à l'intérieur des bâtiments -
Partie 4: Stations de relevage d'effluents - Conception et
calculs

Schwerkraftentwässerungsanlagen innerhalb von
Gebäuden - Teil 4: Abwasserhebeanlagen - Planung und
Bemessung

This European Standard was approved by CEN on 27 October 1999.

CEN members are bound to comply with the CEN/CENELEC Internal Regulations which stipulate the conditions for giving this European Standard the status of a national standard without any alteration. Up-to-date lists and bibliographical references concerning such national standards may be obtained on application to the Central Secretariat or to any CEN member.

This European Standard exists in three official versions (English, French, German). A version in any other language made by translation under the responsibility of a CEN member into its own language and notified to the Central Secretariat has the same status as the official versions.

CEN members are the national standards bodies of Austria, Belgium, Czech Republic, Denmark, Finland, France, Germany, Greece, Iceland, Ireland, Italy, Luxembourg, Netherlands, Norway, Portugal, Spain, Sweden, Switzerland and United Kingdom.



EUROPEAN COMMITTEE FOR STANDARDIZATION
COMITÉ EUROPÉEN DE NORMALISATION
EUROPÄISCHES KOMITEE FÜR NORMUNG

Central Secretariat: rue de Stassart, 36 B-1050 Brussels

Contents

	Page
Foreword	3
1 Scope	3
2 Normative references	3
3 Definitions, symbols, units and designation	4
3.1 Definitions	4
3.1.1 Wastewater lifting plant.....	4
3.1.2 Backflow	4
3.1.3 Flood level	4
3.1.4 Backflow loop.....	4
3.1.5 Duty flow, \dot{V}_p	4
3.1.6 Discharge head, H_p	4
3.1.7 Collection tank for wastewater containing faecal matter.....	4
3.1.8 Useful volume	4
3.2 Symbols	5
4 Protection against backflow	5
5 Installation	7
5.1 General requirements	7
5.2 Pipework.....	7
5.3 Ventilation	10
5.4 Drains	10
5.5 Electrical connections	10
6 Selection of wastewater lifting plants	10
6.1 Determination of flow, Q_p	10
6.2 Determination of head, H_p	10
6.2.1 Calculation procedure for head, H_p	11
6.2.2 Static head, H_{geo}	11
6.2.3 Losses in valves and fittings, $H_{V,A}$	12
6.2.4 Friction losses in discharge pipework, $H_{V,R}$	13
6.3 Determination of useful volume, V	14
7 Commissioning	16
8 Inspection and maintenance	16
8.1 Inspection	16
8.2 Maintenance	16
8.3 Maintenance contract	16
Annex A (informative)	17
Bibliography	19

Foreword

This European Standard has been prepared by Technical Committee CEN/TC 165 "Waste water engineering", the secretariat of which is held by DIN.

This European Standard shall be given the status of a national standard, either by publication of an identical text or by endorsement, at the latest by December 2000, and conflicting national standards shall be withdrawn at the latest by June 2001.

This part is the fourth in a series relating to the functional requirements of gravity drainage systems inside buildings. There will be five parts, as follows: Gravity drainage systems inside buildings:

- Part 1: General and performance requirements
- Part 2: Sanitary pipework - Layout and calculation
- Part 3: Roof drainage - Layout and calculation
- Part 4: Wastewater lifting plants - Layout and calculation
- Part 5: Installation and testing, instructions for operation, maintenance and use

According to the CEN/CENELEC Internal Regulations, the national standards organizations of the following countries are bound to implement this European Standard: Austria, Belgium, Czech Republic, Denmark, Finland, France, Germany, Greece, Iceland, Ireland, Italy, Luxembourg, Netherlands, Norway, Portugal, Spain, Sweden, Switzerland and the United Kingdom.

1 Scope

This part gives layout, operation and maintenance requirements for lifting plants for wastewater containing faecal matter, faecal-free wastewater and rainwater within buildings and sites, together with their discharge pipework and connection to drain. It also covers faecal wastewater lifting plants for limited applications.

2 Normative references

This standard incorporates by dated or undated reference provision from other publications. These normative references are cited at the appropriate places in the text and the publications are listed hereafter. For dated references, subsequent amendments to or revisions to any of these publications apply to this European Standard only when incorporated in it by amendment or revision. For undated references the latest edition of the publication referred to applies.

EN 1085
Wastewater treatment - Vocabulary

prEN 12050-1
Wastewater lifting plants for buildings and sites - Principles of construction and testing - Part 1: Lifting plants for wastewater containing faecal matter

prEN 12050-2
Wastewater lifting plants for buildings and sites - Principles of construction and testing - Part 2: Lifting plants for faecal-free wastewater

prEN 12050-3
Wastewater lifting plants for buildings and sites - Principles of construction and testing - Part 3: Lifting plants for wastewater containing faecal matter for limited applications

prEN 12050-4
Wastewater lifting plants for buildings and sites - Principles of construction and testing - Part 4: Non-return valves for faecal-free wastewater and wastewater containing faecal matter

EN 12056-1
Gravity drainage systems inside buildings - Part 1: General and performance requirements

EN 12056-2
Gravity drainage systems inside buildings - Part 2: Sanitary pipework - Layout and calculation

EN 12056-3
Gravity drainage systems inside buildings - Part 3: Roof drainage - Layout and calculation

EN 12056-5
Gravity drainage systems inside buildings - Part 5: Installation and testing, instructions for operation, maintenance and use

3 Definitions, symbols, units and designation

For the purposes of this standard, EN 1085 and the following definitions and symbols apply:

3.1 Definitions

3.1.1 wastewater lifting plant

device for the collection and automatic lifting of wastewater, which may or may not contain faecal matter, to a height above flood level

3.1.2 backflow

flow of wastewater from a drain or sewer against the direction of flow back into the connected pipework

3.1.3 flood level

the maximum level to which waste water can rise within a drainage system

3.1.4 backflow loop

part of the pressurized pipework from a wastewater lifting plant above flood level (see Figures 1 and 2)

3.1.5 duty flow, \dot{V}_p

flow discharged by the pumping device of the wastewater lifting plant against the total head at the duty point (see Figure 6)

3.1.6 discharge head, H_p

pressure produced by the pumping device of a wastewater lifting plant at the duty point to overcome the static height difference plus the total losses in the discharge pipework (see Figure 6)

3.1.7 collection tank for wastewater containing faecal matter

unpressurized part of a wastewater lifting plant in which the incoming wastewater is stored prior to lifting

3.1.8 useful volume

volume in the collection tank between switch-on level and switch-off level that can be lifted

3.2 Symbols

Table 1 — Symbols

Symbol	Unit	Definition
d_i	mm	Inside diameter
DN	mm	Nominal size
g	m/s^2	Gravitational constant (= 9,81 m/s^2)
H_{geo}	m	Static head
H_P	m	Discharge head of pumping device at duty point
H_{tot}	m	Total head
H_V	m	Head loss
$H_{V,A}$	m	Loss in valves and fittings
$H_{V,j}$	–	Dimensionless head loss as a function of pipe length
$H_{V,R}$	m	Friction loss in discharge pipework
L	m	Pipeline length
P_V	bar (N/m^2)	Pressure loss
Q_i (\dot{V})	l/s	Wastewater inflow
Q (\dot{V}_A)	l/s	Flow generally
Q_P (\dot{V}_P)	l/s	Duty flow of pumping device
Q_R (\dot{V}_R)	l/s	Rainwater discharge
T	s	Minimum running time
V	l	Useful volume
v	m/s	Flow velocity
Z	–	Resistance factor

4 Protection against backflow

Even when a public drain or sewer system is designed in accordance with generally approved calculation methods and carefully maintained, it cannot, for economic reasons, be sized to be able to discharge the unusually large quantities of water which may arise during a heavy storm. Under these conditions surcharge the connecting drains and the building drainage system has to be taken into account.

A similar situation can be caused by unplanned inflows, blockages, overloading or reductions in cross-section.

In addition, failure of a pumping station can cause a sewer to surcharge. For these reasons, sanitary appliances below flood level shall be adequately protected against backflow. If no other information is available, in generally flat areas the level of the highway¹ at the point where the drain connects to the sewer may be assumed to be the flood level.

Protection against backflow may be provided by a wastewater lifting plant with a backflow loop (see Figures 1 and 2). Only a backflow loop will provide a high degree of security against backflow.

Alternatively, an anti-flooding valve may be used (see Figure 3), provided:

- there is a fall to the sewer, and;
- the rooms are of minor importance, i.e. no valuable items are present and the health of the inhabitants will not be affected in the case of flooding, and;
- the number of users is small and a WC is available above flood level, and;
- sanitary appliances do not need to be used during flooding.

¹ "highway" refers to the road, pathways, roadside shoulders, etc.

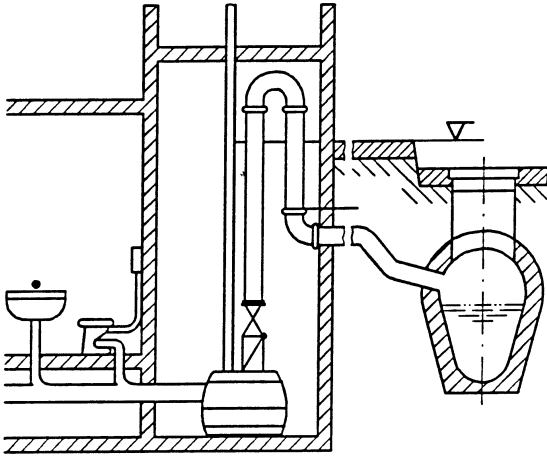

Figure 1 — Illustration of protection against backflow where the drain or sewer is higher than the sanitary appliances

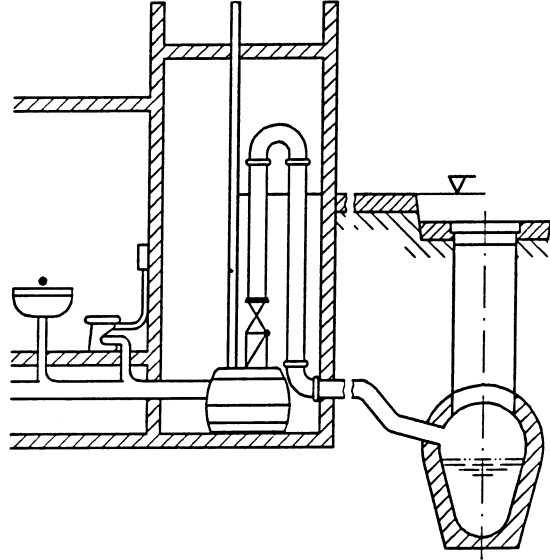

Figure 2 — Illustration of protection against backflow by means of a wastewater lifting plant where there is a fall to the drain or sewer

标准分享网 www.bzfxw.com

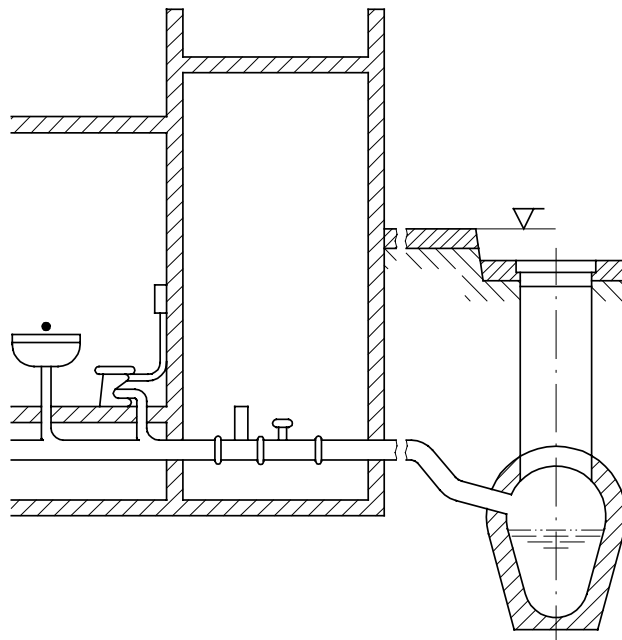

Figure 3 — Illustration of protection of a room of minor importance against backflow by means of anti-flooding valve where there is a natural fall to the sewer

5 Installation

5.1 General requirements

Wastewater lifting plants shall be installed so that rotation is prevented. Wastewater lifting plants that might be subject to flotation shall be fastened down.

Rooms containing wastewater lifting plants shall be of sufficient size to give a working space of at least 600 mm around and above all operating parts or components that may need maintenance. Rooms shall be adequately lit and well ventilated. Where a faecal wastewater lifting plant to prEN 12050-1 is used, a sump shall be provided.

All pipework connections to a wastewater lifting plant shall be noise absorbing.

Collection tanks for wastewater containing faecal matter shall not be structurally connected to the building. Where a faecal wastewater lifting plant is used within a building, it shall have a free-standing collection tank.

In accordance with prEN 12050-1, duplicate pumping devices shall be installed in plants where the wastewater inflow cannot be interrupted.

Surface water drainage of areas below flood level shall be kept separate from domestic wastewater and pumped away using a wastewater lifting plant installed outside the building.

5.2 Pipework

Sanitary pipework below flood level and draining to a wastewater lifting plant shall be designed and installed in accordance with EN 12056.

All pipework shall be installed so that it is self-draining and shall not be restricted or reduced in diameter in the direction of flow. The minimum size of discharge pipework shall be in accordance with Table 2.

Table 2 — Minimum size of discharge pipework

Type of wastewater lifting plant	Minimum size of discharge pipework
Non-macerating faecal lifting plant to prEN 12050-1	DN 80
Macerating faecal lifting plant to prEN 12050-1	DN 32
Faecal-free lifting plant to prEN 12050-2	DN 32
Non-macerating faecal lifting plant for limited applications to prEN 12050-3	DN 25
Macerating faecal lifting plant for limited applications to prEN 12050-3	DN 20

All pipework connected to a lifting plant shall be installed so that it is not under stress and shall be adequately supported.

An isolating valve shall be installed on the inlet of the wastewater lifting plant and also on the discharge side after the non-return valve. For wastewater lifting plants to prEN 12050-2 or prEN 12050-3 with discharge pipework less than DN 80, the isolating valves may be omitted provided that any non-return valve has a backwash device or some other means of emptying the discharge pipework into the collection tank is provided.

Discharge pipework from a wastewater lifting plant shall be installed to form a backflow loop above flood level (see Figures 1 and 2).

No other connections shall be made to the discharge pipework.

Discharge pipework from a wastewater lifting plant shall always be connected to a ventilated drain (see Figures 4 and 5) and never to a stack.

Discharge pipeworks shall be connected to a drain in the same way as for a gravity connection. Cleaning access to the drain shall be provided. Discharge pipework shall be capable of withstanding 1,5-times the maximum operating pressure of the lifting plant.

Air admittance valves shall not be installed in the discharge pipework.

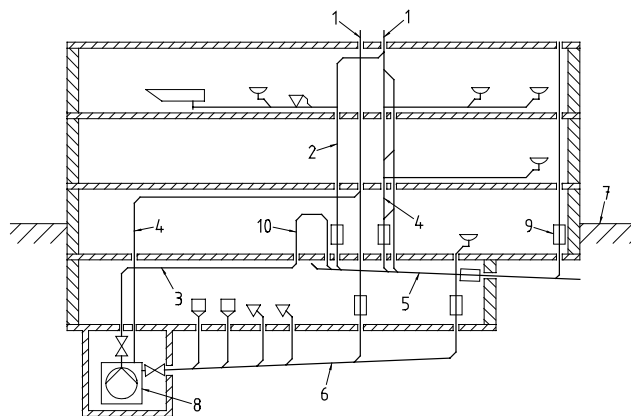

- | | |
|--|--|
| 1 Ventilating pipes | 6 Drain |
| 2 Discharge stack | 7 Flood level |
| 3 Discharge pipework from faecal lifting plant | 8 Faecal lifting plant with non-return valve |
| 4 Ventilating pipe for faecal lifting plant | 9 Access point |
| 5 Drain | 10 Backflow loop |

Figure 4 — Illustration of connection of a faecal lifting plant to a drain

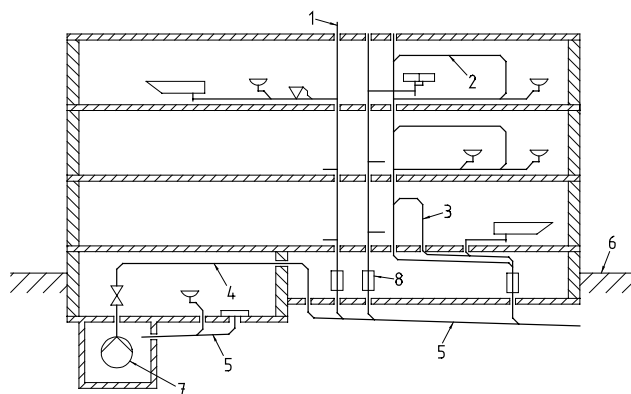

- | | |
|---|--|
| 1 Stack vent | 5 Drain |
| 2 Branch ventilating pipes | 6 Flood level |
| 3 Branch ventilating pipes | 7 Lifting plant for faecal-free wastewater with non-return valve |
| 4 Discharge pipework with backflow loop | 8 Access point |

Figure 5 — Illustration of connection of a lifting plant for faecal-free wastewater to a drain

5.3 Ventilation

Faecal lifting plants to prEN 12050-1 shall be ventilated to above roof level. Ventilating pipes may be connected to either a ventilating stack or a stack vent. Ventilating pipes shall not be connected to the inflow side of the ventilating pipework of a grease separator.

5.4 Drains

Drains shall be sized in accordance with EN 12056-2 and EN 12056-3 and the following requirements:

- a) The capacity of surface water drains, Q_p , shall be greater than the sum of the pumped discharge, Q_R , and the surface water flow calculated in accordance with EN 12056-3.
- b) If a number of wastewater lifting plants discharge into a single drain, the capacity of the drain shall be at least 100% of the largest pumped flow plus $0,4 \times Q_p$ of the sum of the others.

5.5 Electrical connections

Electrical connections shall be carried out by a suitably qualified electrician in accordance with the electrical regulations applying in the country of installation. Any non-waterproof electrical fittings, such as control boxes and alarm units, shall be installed in dry, well-ventilated areas located above flood level.

Where a warning device is specified, this shall be installed so as to warn all premises served by the wastewater lifting plant if a failure should occur.

6 Selection of wastewater lifting plants

In order to select a wastewater lifting plant, the total inflow, Q_i , and the total head, H_{tot} , need to be calculated. A wastewater lifting plant with a duty of Q_p and H_p shall be selected with Q_p greater than Q_i and H_p as close as possible to H_{tot} .

6.1 Determination of flow, Q_p

The total inflow, Q_i , shall be calculated in accordance with EN 12056 -2 or -3, as appropriate.

In addition to the determination specified in EN 12056-2, the velocity in the discharge pipework shall be not less than 0,7 m/s and shall not exceed 2,3 m/s. When selecting a wastewater lifting plant, attention shall be paid to minimum energy usage. Generally Q_p shall be at least Q_i . However, for faecal lifting plants for limited applications according to prEN 12050-3, Q_p may be less than Q_i , if the manufacturer specifies the extent of the reduction.

6.2 Determination of head, H_p

The discharge head, H_p , shall be greater or equal to the total head, H_{tot} . The total head, H_{tot} , shall be calculated as:

$$H_{tot} = H_{geo} + H_V \quad (1)$$

and $H_V = H_{V,A} + H_{V,R} \quad (2)$

where

H_{tot}	total head, in metres;
H_{geo}	static head, in metres;
H_V	head losses (dynamic portion of total head), in metres;
$H_{V,A}$	losses in valves and fittings, in metres;
$H_{V,R}$	friction losses in the discharge pipework, in metres.

Figure 6 shows the relationship between head and flow and illustrates their component parts.

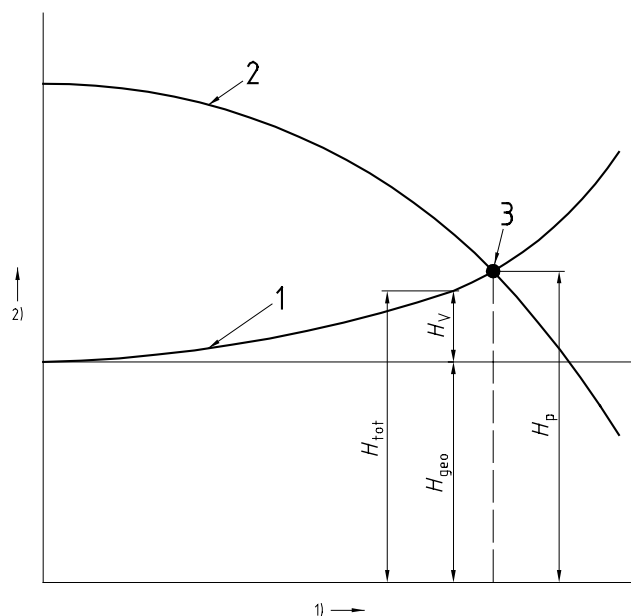

- 1 System curve
- 2 Pump curve
- 3 Duty point

- 1) Flow generally \dot{V}_A
- 2) Discharge head H

Figure 6 — Relationship between head and flow

6.2.1 Calculation procedure for head, H_p

The procedure for the calculation of the discharge head, H_p , is shown in Figure 7.

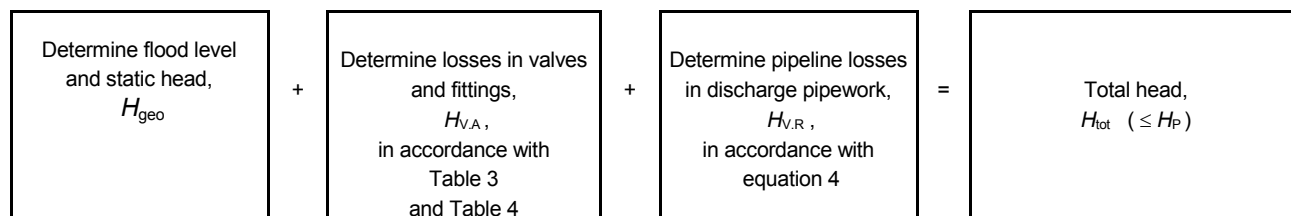

Figure 7 — Calculation method for total head, H_{tot} , and Discharge Head, H_p

6.2.2 Static head, H_{geo}

The static head is calculated as the vertical distance between the lowest water level in the wastewater lifting plant and the highest point of the discharge pipework. For simplification, it is permissible to measure the vertical distance from the floor of the room where the lifting plant is located and the lowest part of the backflow loop (see Figure 8).

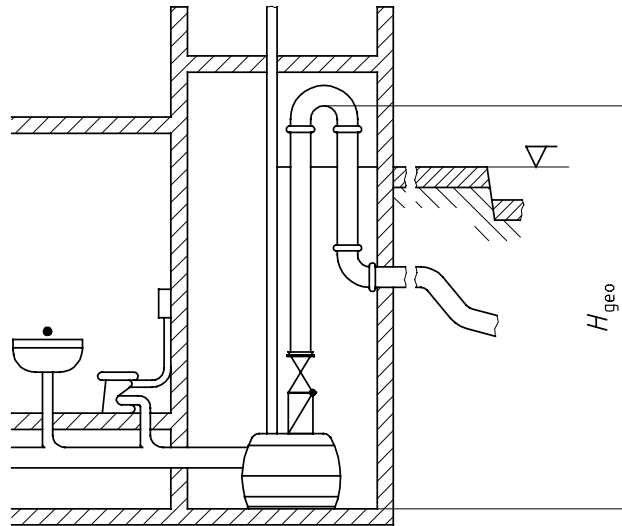

Figure 8 — Static head

6.2.3 Losses in valves and fittings, $H_{V,A}$

The head losses in each individual valve and fitting in the discharge pipework up to the backflow loop shall be calculated individually and summed, i.e.:

$$H_{V,A} = \sum_i \zeta_i \frac{v_i^2}{2g} \quad (3)$$

where

- $H_{V,A}$ losses in valves and fittings, in metres;
- ζ resistance factor, dimensionless;
- g gravitational constant, in metres per second per second;
- v_i velocity in valve or fitting, in metres per second.

Resistance factors for valves and fittings, ζ , are given in Table 3.

Table 3 — Resistance factors ζ for valves and fittings

Type of resistance	ζ
Shut-off valve ^{*)}	0,5
Non-return valve ^{*)}	2,2
Bend 90°	0,5
Bend 45°	0,3
Free outflow	1,0
T-Piece 45° passage in case of flow merging	0,3
T-Piece 90° passage in case of flow merging	0,5
T-Piece 45° branch in case of flow merging	0,6
T-Piece 90° branch in case of flow merging	1,0
T-Piece 90° in case of opposite direction	1,3
Increase in diameter	0,3

^{*)} Specifications provided by the manufacturer should be preferred.

Determination of head losses through valves and fittings is given in Table 4. Alternatively, information supplied by the manufacturer may be used.

Table 4 — Head loss, $H_{V,A}$, and flow velocity, v , in valves and fittings

V m/s	Resistance factor ζ												
	0,4	0,6	0,8	1,0	1,2	1,4	1,6	1,8	2,0	2,5	3,0	3,5	4,0
	Head loss, $H_{V,A}$ m												
0,7	0,010	0,015	0,02	0,025	0,029	0,034	0,039	0,044	0,049	0,061	0,074	0,086	0,098
0,8	0,013	0,019	0,026	0,032	0,038	0,045	0,051	0,058	0,064	0,080	0,096	0,112	0,128
0,9	0,016	0,024	0,032	0,041	0,049	0,057	0,065	0,073	0,081	0,101	0,122	0,142	0,162
1,0	0,02	0,030	0,040	0,050	0,060	0,070	0,080	0,090	0,100	0,125	0,150	0,175	0,200
1,1	0,024	0,036	0,048	0,061	0,073	0,085	0,097	0,109	0,121	0,151	0,182	0,212	0,242
1,2	0,029	0,043	0,058	0,072	0,086	0,101	0,115	0,130	0,144	0,180	0,216	0,252	0,288
1,3	0,034	0,051	0,068	0,085	0,101	0,118	0,135	0,152	0,169	0,211	0,254	0,296	0,338
1,4	0,039	0,059	0,078	0,098	0,118	0,137	0,157	0,176	0,196	0,245	0,294	0,343	0,392
1,5	0,045	0,068	0,090	0,113	0,135	0,158	0,180	0,203	0,225	0,281	0,338	0,394	0,450
1,6	0,051	0,077	0,102	0,128	0,154	0,179	0,205	0,230	0,256	0,320	0,384	0,448	0,512
1,7	0,058	0,087	0,116	0,145	0,173	0,202	0,231	0,260	0,289	0,361	0,434	0,506	0,578
1,8	0,065	0,097	0,130	0,162	0,194	0,227	0,259	0,292	0,324	0,405	0,486	0,567	0,648
1,9	0,072	0,108	0,144	0,181	0,217	0,253	0,289	0,325	0,361	0,451	0,542	0,632	0,722
2,0	0,080	0,120	0,160	0,200	0,240	0,280	0,320	0,360	0,400	0,500	0,600	0,700	0,800
2,1	0,088	0,132	0,176	0,221	0,265	0,309	0,353	0,397	0,441	0,551	0,662	0,772	0,882
2,2	0,097	0,145	0,194	0,242	0,290	0,339	0,387	0,436	0,484	0,605	0,726	0,847	0,968
2,3	0,106	0,159	0,212	0,265	0,317	0,370	0,423	0,476	0,529	0,661	0,794	0,926	1,058
2,4	0,115	0,173	0,230	0,288	0,346	0,403	0,461	0,518	0,576	0,720	0,864	1,008	1,152
2,5	0,125	0,188	0,250	0,313	0,375	0,438	0,500	0,563	0,625	0,781	0,938	1,094	1,250

6.2.4 Friction losses in discharge pipework, $H_{V,R}$

Friction losses, $H_{V,R}$, are determined in accordance with Figure 9, annex A or using manufacturer's information for all straight pipes in the discharge pipework up to the backflow loop, i.e.:

$$H_{V,R} = \sum_j H_{V,j} \times L_j \quad (3)$$

where

$H_{V,R}$ friction losses in discharge pipework, in metres;
 $H_{V,j}$ head loss as function of pipe length, dimensionless;
 L_j length of straight pipes, in metres.

Alternatively, $H_{V,j}$, may be calculated using the Colebrook-White² equation. The values for the head loss, $H_{V,j}$, apply to pure water at 10°C or for liquids of similar kinematic viscosity and a full pipeline.

² Also known as the Prandtl-Colebrook equation.

Example:

Given: pipe DN 80
rate of flow 20 m³/h

value read: $H_{V,j} = 0,022$

Head loss in a pipe of length $L_j = 10$ m: $H_{V,R} = 0,022 \times 10\text{m} = 0,22$ m.

6.3 Determination of useful volume, V

This clause does not apply to faecal lifting plants for limited applications complying with EN 12050-3.

The recommended useful volume is determined in accordance with

$$V = T \times Q_P \quad (5)$$

where

V useful volume, in litres;
 T minimum running time, in seconds, from Table 5;
 Q_P pump flow, in litres per second.

Table 5 — Relation between motor power and minimum running time

Motor power kW	Minimum running time, T s
to 2,5	2,2
2,5 to 7,5	5,5
over 7,5	8,5
Note 1: These factors are based on experience.	

The lifting plant manufacturer may specify other values for the minimum running time T . The useful volume shall be greater than the volume in the discharge pipework between the non-return valve and the backflow loop. In order to ensure that the contents of the discharge pipework are turned over during each pumping sequence, the minimum useful volume shall be 20 l.

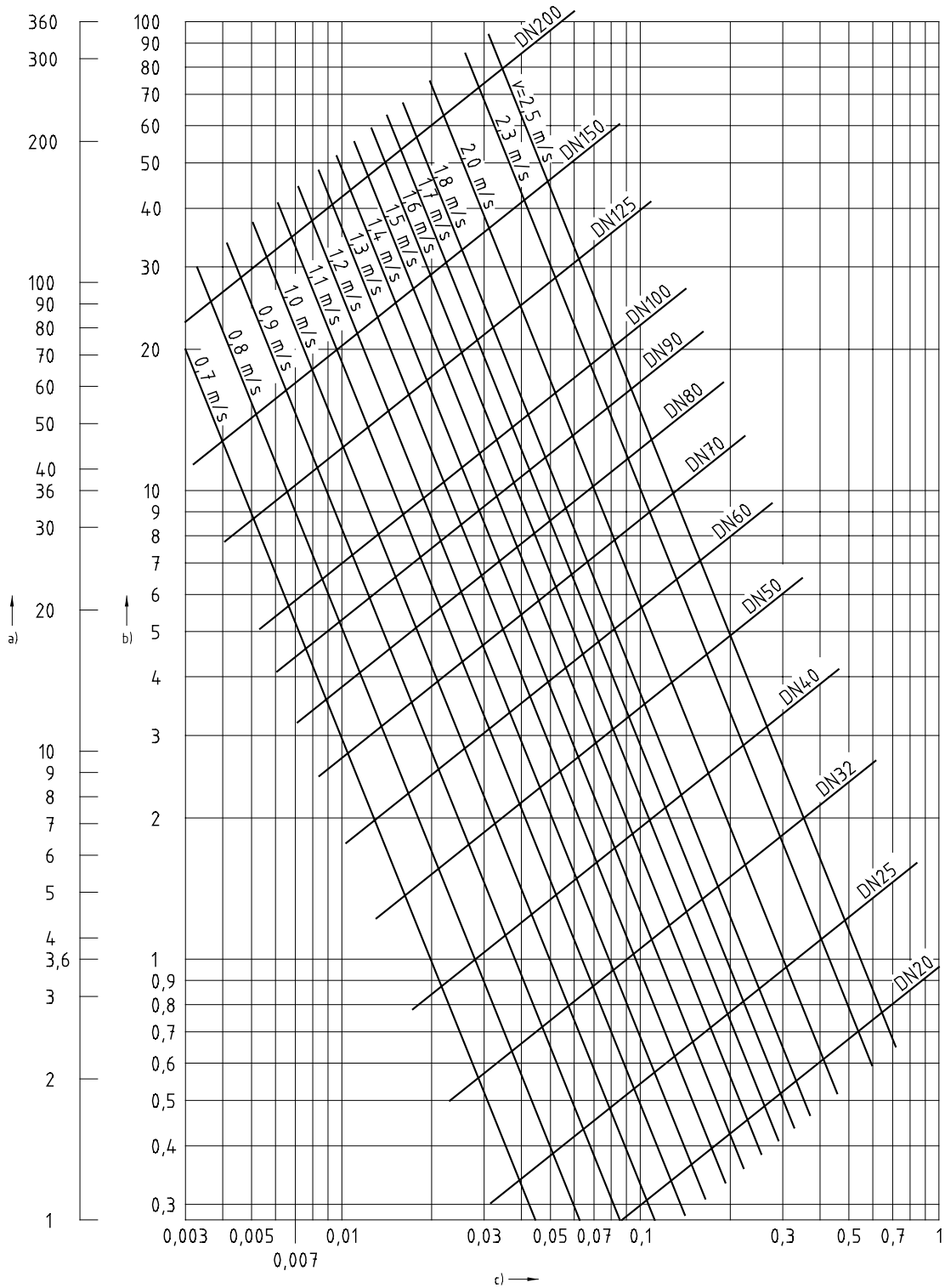

a) rate of flow Q in m^3/h b) rate of flow Q in l/s c) head loss $H_{v,j}$ without dimension

Figure 9 — Dimensionless head loss $H_{v,j}$ in relationship to the internal diameter of the pipe, d , flow velocity, v , and rate of flow Q^3

³ Annex A contains a numerical depiction of the diagram

7 Commissioning

The plant shall be commissioned by a suitably qualified person. The supplier of the wastewater lifting plant is responsible for ensuring the availability of this person. Testing with water for a minimum of two switching sequences is required for commissioning. During the test, dry running shall be avoided. The following items shall be checked before, during and after testing:

- a) electrical safety in accordance with IEC or local regulations;
- b) direction of rotation of the motor;
- c) valves (operation, opening, sealing);
- d) switching and setting of the control levels in the collection tank, where not preset by the manufacturer;
- e) watertightness of plant, valves and pipes;
- f) rated voltage and frequency;
- g) functional test of the non-return valve;
- h) warning device; in combination with a second switching circuit where applicable;
- i) discharge pipework support;
- j) motor protection switch (by removing individual fuses (two-phase running));
- k) oil level (if oil chamber fitted);
- l) control lights, gauges and meters;
- m) operation of hand pump, where fitted.

Commissioning shall be recorded in writing, including important data such as the setting of the motor overload switch and the readings from hours-run meters.

8 Inspection and maintenance

8.1 Inspection

Wastewater lifting plants should be inspected monthly by observing at least two switching cycles and checking the operation.

8.2 Maintenance

Lifting plants shall be maintained regularly by a suitably qualified person. The time between maintenance checks shall not be greater than:

- 1/4 year for plants in commercial premises;
- 1/2 year for plants serving multiple dwellings;
- 1 year for plants in single dwellings.

Maintenance shall include:

- a) checking by visual inspection all connection points for leakage;
- b) operation of valves, checking ease of operation and sealing. If necessary, reset and grease;
- c) opening and closing of non-return valves; checking seating and ball/flap; functional check;
- d) cleaning the pumping unit and the pipework directly connected to it; checking impeller and bearings;
- e) checking oil level, where necessary, refill or change oil (if oil chamber fitted);
- f) internal cleaning of tank (if required or under special circumstances);
- g) visual inspection of the electrical part of the plant;
- h) visually checking condition of collection tank;
- i) every two years rinse out plant with water.

After carrying out maintenance, the plant shall be recommissioned in accordance with clause 7. A log should be kept of all maintenance work, detailing any work carried out and the applicable information. If faults are found that cannot be corrected, these shall be notified in writing to the operator of the wastewater lifting plant and an acknowledgement requested.

8.3 Maintenance contract

Owners of lifting plants are recommended to take out a maintenance contract to cover regular maintenance and repair work.

Annex A (informative)

Table A.1 — Determination of dimensionless head loss $H_{V,j}$ in straight piping systems with a operating roughness of $k_b = 0,25$ mm in relationship to the nominal size of the pipe, DN, flow velocity, v , and rate of flow Q

m ³ /h	DN 20 $d_1 = 20,0$ mm		DN 25 $d_1 = 25,0$ mm		DN 32 $d_1 = 32,0$ mm		DN 40 $d_1 = 40,0$ mm		DN 50 $d_1 = 50,0$ mm		DN 60 $d_1 = 60,0$ mm	
	$H_{V,j}$	v m/s	$H_{V,j}$	v m/s	$H_{V,j}$	v m/s	$H_{V,j}$	v m/s	$H_{V,j}$	v m/s	$H_{V,j}$	v m/s
1,0	0,087	0,9	-	-	-	-	-	-	-	-	-	-
1,2	0,124	1,1	0,039	0,7	-	-	-	-	-	-	-	-
1,4	0,167	1,2	0,052	0,8	-	-	-	-	-	-	-	-
1,6	0,216	1,4	0,067	0,9	-	-	-	-	-	-	-	-
1,8	0,272	1,6	0,085	1,0	-	-	-	-	-	-	-	-
2,0	0,334	1,8	0,104	1,1	0,029	0,7	-	-	-	-	-	-
2,2	0,403	1,9	0,125	1,2	0,035	0,8	-	-	-	-	-	-
2,4	0,478	2,1	0,148	1,4	0,041	0,8	-	-	-	-	-	-
2,6	0,559	2,3	0,173	1,5	0,048	0,9	-	-	-	-	-	-
2,8	-	-	0,200	1,6	0,055	1,0	-	-	-	-	-	-
3,0	-	-	0,228	1,7	0,063	1,0	0,020	0,7	-	-	-	-
3,2	-	-	0,259	1,8	0,071	1,1	0,022	0,7	-	-	-	-
3,4	-	-	0,292	1,9	0,080	1,2	0,025	0,8	-	-	-	-
3,6	-	-	0,327	2,0	0,090	1,2	0,028	0,8	-	-	-	-
3,8	-	-	0,363	2,2	0,100	1,3	0,031	0,8	-	-	-	-
4,0	-	-	0,402	2,3	0,110	1,4	0,034	0,9	-	-	-	-
4,2	-	-	-	-	0,121	1,5	0,038	0,9	-	-	-	-
4,4	-	-	-	-	0,132	1,5	0,041	1,0	-	-	-	-
4,6	-	-	-	-	0,144	1,6	0,045	1,0	0,014	0,7	-	-
4,8	-	-	-	-	0,157	1,7	0,049	1,1	0,015	0,7	-	-
5,0	-	-	-	-	0,170	1,7	0,053	1,1	0,017	0,7	-	-
5,2	-	-	-	-	0,184	1,8	0,057	1,1	0,018	0,7	-	-
5,4	-	-	-	-	0,198	1,9	0,062	1,2	0,019	0,8	-	-
5,6	-	-	-	-	0,212	1,9	0,066	1,2	0,021	0,8	-	-
5,8	-	-	-	-	0,228	2,0	0,071	1,3	0,022	0,8	-	-
6,0	-	-	-	-	0,243	2,1	0,076	1,3	0,024	0,8	-	-
6,2	-	-	-	-	0,259	2,1	0,081	1,4	0,025	0,9	-	-
6,4	-	-	-	-	0,276	2,2	0,086	1,4	0,027	0,9	-	-
6,6	-	-	-	-	0,293	2,3	0,091	1,5	0,029	0,9	-	-
6,8	-	-	-	-	0,311	2,3	0,097	1,5	0,030	1,0	0,012	0,7
7,0	-	-	-	-	-	-	0,102	1,5	0,032	1,0	0,013	0,7
7,2	-	-	-	-	-	-	0,108	1,6	0,034	1,0	0,013	0,7
7,4	-	-	-	-	-	-	0,114	1,6	0,036	1,0	0,014	0,7
7,6	-	-	-	-	-	-	0,120	1,7	0,038	1,1	0,015	0,7
7,8	-	-	-	-	-	-	0,126	1,7	0,040	1,1	0,015	0,8
8,0	-	-	-	-	-	-	0,133	1,8	0,042	1,1	0,016	0,8
8,2	-	-	-	-	-	-	0,139	1,8	0,044	1,2	0,017	0,8
8,4	-	-	-	-	-	-	0,146	1,9	0,046	1,2	0,018	0,8
8,6	-	-	-	-	-	-	0,153	1,9	0,048	1,2	0,019	0,8
8,8	-	-	-	-	-	-	0,160	1,9	0,050	1,2	0,019	0,9
9,0	-	-	-	-	-	-	0,167	2,0	0,052	1,3	0,02	0,9
9,2	-	-	-	-	-	-	0,175	2,0	0,054	1,3	0,021	0,9
9,4	-	-	-	-	-	-	0,182	2,1	0,057	1,3	0,022	0,9
9,6	-	-	-	-	-	-	0,190	2,1	0,059	1,4	0,023	0,9
9,8	-	-	-	-	-	-	0,198	2,2	0,062	1,4	0,024	1,0
10,0	-	-	-	-	-	-	0,206	2,2	0,064	1,4	0,025	1,0
10,2	-	-	-	-	-	-	0,214	2,3	0,067	1,4	0,026	1,0
10,4	-	-	-	-	-	-	0,222	2,3	0,069	1,5	0,027	1,0
10,6	-	-	-	-	-	-	0,231	2,3	0,072	1,5	0,028	1,0
10,8	-	-	-	-	-	-	-	-	0,074	1,5	0,029	1,1

(continued)

Table A.1 (completed)

m ³ /h	DN 60 d ₁ = 60,0mm		DN 70 d ₁ = 70,0 mm		DN 80 d ₁ = 80,0 mm		DN 90 d ₁ = 90,0 mm		DN 100 d ₁ = 100,0 mm		DN 125 d ₁ = 125,0 mm	
	H _{vj}	v m/s	H _{vj}	v m/s	H _{vj}	v m/s	H _{vj}	v m/s	H _{vj}	v m/s	H _{vj}	v m/s
11,0	0,003	1,1	0,014	0,8	-	-	-	-	-	-	-	-
11,5	0,033	1,1	0,015	0,8	-	-	-	-	-	-	-	-
12,0	0,035	1,2	0,016	0,9	-	-	-	-	-	-	-	-
12,5	0,038	1,2	0,017	0,9	-	-	-	-	-	-	-	-
13,0	0,041	1,3	0,019	0,9	0,090	0,7	-	-	-	-	-	-
13,5	0,045	1,3	0,020	1,0	0,01	0,7	-	-	-	-	-	-
14,0	0,048	1,4	0,022	1,0	0,011	0,8	-	-	-	-	-	-
14,5	0,051	1,4	0,023	1,0	0,012	0,8	-	-	-	-	-	-
15,0	0,055	1,5	0,025	1,1	0,012	0,8	-	-	-	-	-	-
15,5	0,058	1,5	0,026	1,1	0,013	0,9	-	-	-	-	-	-
16,0	0,062	1,6	0,028	1,2	0,014	0,9	-	-	-	-	-	-
16,5	0,066	1,6	0,03	1,2	0,015	0,9	0,008	0,7	-	-	-	-
17,0	0,070	1,7	0,031	1,2	0,016	0,9	0,009	0,7	-	-	-	-
17,5	0,074	1,7	0,033	1,3	0,017	1,0	0,009	0,8	-	-	-	-
18,0	0,078	1,8	0,035	1,3	0,018	1,0	0,01	0,8	-	-	-	-
20,0	0,096	2,0	0,043	1,4	0,022	1,1	0,012	0,9	0,007	0,7	-	-
22,0	0,116	2,2	0,052	1,6	0,026	1,2	0,014	1,0	0,008	0,8	-	-
24,0	-	-	0,062	1,7	0,031	1,3	0,017	1,0	0,01	0,8	-	-
26,0	-	-	0,072	1,9	0,036	1,4	0,02	1,1	0,011	0,9	-	-
28,0	-	-	0,083	2,0	0,042	1,5	0,023	1,2	0,013	1,0	-	-
30,0	-	-	0,095	2,2	0,048	1,7	0,026	1,3	0,015	1,1	-	-
32,0	-	-	-	-	0,054	1,8	0,029	1,4	0,017	1,1	0,005	0,7
34,0	-	-	-	-	0,061	1,9	0,033	1,5	0,019	1,2	0,006	0,8
36,0	-	-	-	-	0,068	2,0	0,037	1,6	0,021	1,3	0,007	0,8
38,0	-	-	-	-	0,076	2,1	0,041	1,7	0,024	1,3	0,008	0,9
40,0	-	-	-	-	0,084	2,2	0,045	1,7	0,026	1,4	0,008	0,9
42,0	-	-	-	-	-	-	0,050	1,8	0,029	1,5	0,009	1,0
44,0	-	-	-	-	-	-	0,055	1,9	0,032	1,6	0,01	1,0
46,0	-	-	-	-	-	-	0,060	2,0	0,034	1,6	0,011	1,0
48,0	-	-	-	-	-	-	0,065	2,1	0,037	1,7	0,012	1,1
50,0	-	-	-	-	-	-	0,070	2,2	0,041	1,8	0,013	1,1
52,0	-	-	-	-	-	-	0,076	2,3	0,044	1,8	0,014	1,2
54,0	-	-	-	-	-	-	-	-	0,047	1,9	0,015	1,2
56,0	-	-	-	-	-	-	-	-	0,051	2,0	0,016	1,3
58,0	-	-	-	-	-	-	-	-	0,054	2,1	0,017	1,3
60,0	-	-	-	-	-	-	-	-	0,058	2,1	0,018	1,4
62,0	-	-	-	-	-	-	-	-	0,062	2,2	0,019	1,4
64,0	-	-	-	-	-	-	-	-	0,066	2,3	0,021	1,4
66,0	-	-	-	-	-	-	-	-	-	-	0,022	1,5
68,0	-	-	-	-	-	-	-	-	-	-	0,023	1,5
70,0	-	-	-	-	-	-	-	-	-	-	0,025	1,6
72,0	-	-	-	-	-	-	-	-	-	-	0,026	1,6
74,0	-	-	-	-	-	-	-	-	-	-	0,027	1,7
76,0	-	-	-	-	-	-	-	-	-	-	0,029	1,7
78,0	-	-	-	-	-	-	-	-	-	-	0,030	1,8
80,0	-	-	-	-	-	-	-	-	-	-	0,032	1,8
82,0	-	-	-	-	-	-	-	-	-	-	0,034	1,9
84,0	-	-	-	-	-	-	-	-	-	-	0,035	1,9
86,0	-	-	-	-	-	-	-	-	-	-	0,037	1,9
88,0	-	-	-	-	-	-	-	-	-	-	0,039	2,0

Bibliography

EN 752-6 : 1995

Drain and sewer systems outside buildings - Part 6: Pumping installations

BSI — British Standards Institution

BSI is the independent national body responsible for preparing British Standards. It presents the UK view on standards in Europe and at the international level. It is incorporated by Royal Charter.

Revisions

British Standards are updated by amendment or revision. Users of British Standards should make sure that they possess the latest amendments or editions.

It is the constant aim of BSI to improve the quality of our products and services. We would be grateful if anyone finding an inaccuracy or ambiguity while using this British Standard would inform the Secretary of the technical committee responsible, the identity of which can be found on the inside front cover. Tel: 020 8996 9000. Fax: 020 8996 7400.

BSI offers members an individual updating service called PLUS which ensures that subscribers automatically receive the latest editions of standards.

Buying standards

Orders for all BSI, international and foreign standards publications should be addressed to Customer Services. Tel: 020 8996 9001. Fax: 020 8996 7001.

In response to orders for international standards, it is BSI policy to supply the BSI implementation of those that have been published as British Standards, unless otherwise requested.

Information on standards

BSI provides a wide range of information on national, European and international standards through its Library and its Technical Help to Exporters Service. Various BSI electronic information services are also available which give details on all its products and services. Contact the Information Centre. Tel: 020 8996 7111. Fax: 020 8996 7048.

Subscribing members of BSI are kept up to date with standards developments and receive substantial discounts on the purchase price of standards. For details of these and other benefits contact Membership Administration. Tel: 020 8996 7002. Fax: 020 8996 7001.

Copyright

Copyright subsists in all BSI publications. BSI also holds the copyright, in the UK, of the publications of the international standardization bodies. Except as permitted under the Copyright, Designs and Patents Act 1988 no extract may be reproduced, stored in a retrieval system or transmitted in any form or by any means – electronic, photocopying, recording or otherwise – without prior written permission from BSI.

This does not preclude the free use, in the course of implementing the standard, of necessary details such as symbols, and size, type or grade designations. If these details are to be used for any other purpose than implementation then the prior written permission of BSI must be obtained.

If permission is granted, the terms may include royalty payments or a licensing agreement. Details and advice can be obtained from the Copyright Manager. Tel: 020 8996 7070.