

Steel wire and wire products — Hose reinforcement wire

The European Standard EN 10324:2004 has the status of a British Standard

ICS 77.140.65

National foreword

This British Standard is the official English language version of EN 10324:2004. It supersedes BS 3592-2:1992 which is withdrawn.

The UK participation in its preparation was entrusted to Technical Committee ISE/26, Steel wire, which has the responsibility to:

- aid enquirers to understand the text;
- present to the responsible international/European committee any enquiries on the interpretation, or proposals for change, and keep the UK interests informed;
- monitor related international and European developments and promulgate them in the UK.

A list of organizations represented on this committee can be obtained on request to its secretary.

Cross-references

The British Standards which implement international or European publications referred to in this document may be found in the *BSI Catalogue* under the section entitled “International Standards Correspondence Index”, or by using the “Search” facility of the *BSI Electronic Catalogue* or of British Standards Online.

This publication does not purport to include all the necessary provisions of a contract. Users are responsible for its correct application.

Compliance with a British Standard does not of itself confer immunity from legal obligations.

Summary of pages

This document comprises a front cover, an inside front cover, the EN title page, pages 2 to 13 and a back cover.

The BSI copyright notice displayed in this document indicates when the document was last issued.

Amendments issued since publication

Amd. No.	Date	Comments

This British Standard was published under the authority of the Standards Policy and Strategy Committee on 10 January 2005

© BSI 10 January 2005

ISBN 0 580 45216 6

ICS

English version

Steel wire and wire products - Hose reinforcement wire

Fils et produits tréfilés en acier - Fil d'armature pour
flexiblesStahldraht und Drahterzeugnisse -
Schlaucharmierungsdraht

This European Standard was approved by CEN on 1 July 2004.

CEN members are bound to comply with the CEN/CENELEC Internal Regulations which stipulate the conditions for giving this European Standard the status of a national standard without any alteration. Up-to-date lists and bibliographical references concerning such national standards may be obtained on application to the Central Secretariat or to any CEN member.

This European Standard exists in three official versions (English, French, German). A version in any other language made by translation under the responsibility of a CEN member into its own language and notified to the Central Secretariat has the same status as the official versions.

CEN members are the national standards bodies of Austria, Belgium, Cyprus, Czech Republic, Denmark, Estonia, Finland, France, Germany, Greece, Hungary, Iceland, Ireland, Italy, Latvia, Lithuania, Luxembourg, Malta, Netherlands, Norway, Poland, Portugal, Slovakia, Slovenia, Spain, Sweden, Switzerland and United Kingdom.



EUROPEAN COMMITTEE FOR STANDARDIZATION
COMITÉ EUROPÉEN DE NORMALISATION
EUROPÄISCHES KOMITEE FÜR NORMUNG

Management Centre: rue de Stassart, 36 B-1050 Brussels

Contents

	Page
Foreword.....	3
1 Scope	4
2 Normative references	4
3 Terms and definitions	4
4 Classification.....	5
5 Designation and ordering	5
5.1 Designation	5
5.2 Information to be supplied by the purchaser and items to be agreed	5
6 Requirements	6
6.1 Material	6
6.1.1 Steel	6
6.1.2 Chemical composition	6
6.1.3 Wire	6
6.1.4 Coating material.....	6
6.2 Mechanical properties.....	7
6.2.1 Tensile strength and elongation	7
6.2.2 Reverse bend test.....	7
6.2.3 Torsion test	7
6.3 Surface quality	9
6.3.1 General.....	9
6.3.2 Coating mass	9
6.4 Dimensions and tolerances	9
6.4.1 Tolerance on diameter	9
6.4.2 Out of roundness	9
6.5 Delivery conditions.....	9
6.5.1 Unit package.....	9
6.5.2 Welds	9
6.5.3 Cast of wire.....	10
7 Testing and inspection.....	10
7.1 Tests and inspection documents.....	10
7.2 Test procedures	10
7.2.1 Tensile test	10
7.2.2 Reverse bend test and torsion test.....	10
7.2.3 Diameter and out of roundness.....	10
7.3 Coating mass	10
7.4 Retests	10
8 Marking, labelling and packaging	10
Annex A (informative) Packaging of hose reinforcement wire.....	12
A.1 Recommended types of spool.....	12
A.2 Recommended length of wire per spool	13

Foreword

This document (EN 10324:2004) has been prepared by Technical Committee ECISS/TC 30 "Steel wire", the secretariat of which is held by BSI.

This European Standard shall be given the status of a national standard, either by publication of an identical text or by endorsement, at the latest by March 2005, and conflicting national standards shall be withdrawn at the latest by March 2005.

According to the CEN/CENELEC Internal Regulations, the national standards organizations of the following countries are bound to implement this European Standard: Austria, Belgium, Cyprus, Czech Republic, Denmark, Estonia, Finland, France, Germany, Greece, Hungary, Iceland, Ireland, Italy, Latvia, Lithuania, Luxembourg, Malta, Netherlands, Norway, Poland, Portugal, Slovakia, Slovenia, Spain, Sweden, Switzerland and United Kingdom.

1 Scope

This document specifies the composition, dimensions and mechanical properties of high carbon steel wire for reinforcing high pressure hoses. It is applicable to wire used as a multiple parallel wire braided or spirally wrapped reinforcement in a rubber or synthetic hose which is made to withstand relatively high bursting pressure.

2 Normative references

The following referenced documents are indispensable for the application of this document. For dated references, only the edition cited applies. For undated references, the latest edition of the referenced document (including any amendments) applies.

EN 10002-1, *Metallic materials — Tensile testing — Part 1: Method of test at ambient temperature*

EN 10016-1, *Non-alloy steel rod for drawing and/or cold rolling — Part 1: General requirements*

EN 10016-2, *Non-alloy steel rod for drawing and/or cold rolling — Part 2: Specific requirements for general purposes rod*

EN 10016-4, *Non-alloy steel rod for drawing and/or cold rolling — Part 4: Specific requirements for rod for special applications*

EN 10021, *General technical delivery requirements for steel and iron products*

EN 10204, *Metallic products — Types of inspection documents*

EN 10218-1:1994, *Steel wire and wire products — General — Part 1: Test methods*

EN 10218-2, *Steel wire and wire products — General — Part 2: Wire dimensions and tolerances*

EN 10244-1, *Steel wire and wire products – Non-ferrous metallic coatings on steel wire – Part 1: General principles*

EN 10244-6, *Steel wire and wire products – Non-ferrous metallic coatings on steel wire – Part 6: Copper, bronze or brass coatings*

CR 10261, *ECISS Information Circular 11 – Iron and steel – Review of available methods of chemical analysis*

3 Terms and definitions

For the purposes of this document, the following terms and definitions apply.

3.1
nominal diameter: d
value of the diameter, expressed in millimetres, by which the wire is designated and specified by the purchaser

NOTE This is the basis on which the values of all relevant characteristics are determined for the acceptance of the wire

3.2
actual diameter
arithmetic mean of two measurements of the diameter at right angles determined at any cross-section

3.3**out of roundness**

arithmetic difference between the maximum and minimum diameter measured in a transverse cross-section perpendicular to the wire axis

4 Classification

Hose wire is classified according to tensile strength. It is supplied in three classes of tensile strength:

- NT: Normal tensile strength;
- HT: High tensile strength;
- ST: Super tensile strength.

5 Designation and ordering**5.1 Designation**

For hose wire supplied in accordance with this document, the designation shall state in the following order:

- the term: hose wire;
- the coating: see **6.1.4**;
- the number of this document;
- the tensile strength class (see **4**) and the nominal tensile strength;
- the nominal diameter.

EXAMPLE Brass coated hose wire 0,30 mm high tensile strength 2750 MPa to 3050 MPa in accordance with EN 10324 shall be designated:

Hose wire brass coated EN 10324 HT 2750 MPa to 3050 MPa 0,30.

5.2 Information to be supplied by the purchaser and items to be agreed

The purchaser shall clearly state in his enquiry or order the product and following information:

- the required nominal diameter;
- the desired quantity;
- the unit and type of package (for recommended types of spools see **A.1**);
- if a coating other than brass is required (see **6.1.4**);
- the type of inspection document.

The following shall be agreed between the purchaser and the supplier at enquiry or order:

- specification of the coating if a coating other than brass is required (see **6.1.4**);

- value of the circular cast if it is required to be less than 100 mm or more than 250 mm (see 6.5.3);
- additional information to be included on the spool and unit package labels (see 8).

EXAMPLE 20 t hose wire brass coated EN 10324 HT 2750 MPa to 3050 MPa 0,30 on spools of 30 kg doc EN 10204"3.1.B."

6 Requirements

6.1 Material

6.1.1 Steel

The wire shall be manufactured from steel rod conforming to EN 10016-1 and EN 10016-2 for tensile strength NT and conforming to EN 10016-4 for tensile strengths HT and ST.

6.1.2 Chemical composition

The chemical composition according to the heat analysis shall conform to the limit values given in Table 1. The permissible deviation of the product analysis from the heat analysis shall be in accordance with EN 10016-2 and EN 10016-4.

Table 1 — Chemical composition (% by mass)

Type	C	Si	Mn	P max.	S max.
NT	0,60 to 0,80	0,15 to 0,30	0,40 to 0,70	0,035	0,035
HT and ST	0,75 to 0,90	0,15 to 0,30	0,40 to 0,60	0,020	0,025

Unless otherwise agreed at the time of enquiry and order, the choice of a suitable physical or chemical method of analysis for the determination of the product analysis shall be at the discretion of the supplier.

In cases of dispute, the analysis shall be carried out by a laboratory approved by the two parties. The method of analysis to be applied shall be agreed upon, if possible, in accordance with CR 10261.

6.1.3 Wire

The wire shall be patented and cold drawn in order to provide the required mechanical properties.

6.1.4 Coating material

If not otherwise stipulated by the purchaser at the time of enquiry or order (see 5.2), the coating material shall be brass with a chemical composition of Cu: $(67 \pm 5) \%$ and the remainder zinc.

In the case of other coatings, the specification shall be agreed between the purchaser and supplier at the time of enquiry or order (see 5.2).

6.2 Mechanical properties

6.2.1 Tensile strength and elongation

When tested in accordance with 7.2.1 before and after the braiding operation the wire shall conform to the tensile strength values and have an elongation at rupture as specified in Table 2.

6.2.2 Reverse bend test

When tested in accordance with 7.2.2 the wire shall withstand the minimum number of bends specified in Table 2 without rupture.

6.2.3 Torsion test

When tested in accordance with 7.2.2 the wire shall withstand the minimum number of torsions specified in Table 2 without fracture.

Table 2 — Mechanical properties

Diameter d^a (mm)	Tensile strength (MPa) ^b	Elongation at rupture (At) % min.	Reverse bends (Nb) on $r: 2,5$ mm min.	Torsion (Nt) ($l = 100 d$) min.
Normal tensile (NT)				
0,25	2450 to 2750	1,6	125	41
0,28	2450 to 2750	1,6	110	40
0,30	2450 to 2750	1,6	95	39
0,34	2450 to 2750	1,6	80	36
0,38	2450 to 2750	1,6	65	35
0,40	2450 to 2750	1,6	60	34
0,45	2450 to 2750	1,8	50	32
0,50	2450 to 2750	1,9	35	31
0,56	2450 to 2750	2,0	30	29
0,60	2450 to 2750	2,0	28	28
0,65	2450 to 2750	2,2	27	27
0,71	2450 to 2750	2,2	25	25
0,80	2150 to 2450	2,2	22	24
High Tensile (HT)				
0,20	2750 to 3050	1,3	160	41
0,25	2750 to 3050	1,6	120	40
0,28	2750 to 3050	1,6	100	39
0,30	2750 to 3050	1,6	85	38
0,34	2750 to 3050	1,6	70	35
0,35	2750 to 3050	1,6	70	32
0,38	2750 to 3050	1,6	60	32
0,40	2750 to 3050	1,6	50	30
0,45	2750 to 3050	1,8	40	27
0,50	2750 to 3050	1,9	25	25
0,56	2750 to 3050	2,0	25	24
0,60	2750 to 3050	2,0	20	23
Super Tensile (ST)				
0,20	3050 to 3350	1,3	110	33
0,25	3050 to 3350	1,6	80	32
0,30	3050 to 3350	1,6	60	32
0,38	3050 to 3350	1,6	40	26

^a For intermediate sizes the requirements shall be those given for the next higher size of the same tensile strength class.
^b 1MPa = 1N/mm².

6.3 Surface quality

6.3.1 General

The surface of the wire shall be smooth and free from grease and other contaminants. The surface of the wire shall provide good adhesion between the wire surface and the rubber.

6.3.2 Coating mass

When measured in accordance with 7.3 the mass of coating on the wire shall be in accordance with the values listed in Table 3.

Table 3 — Coating mass

Diameter d (mm)	Coating mass (kgm)
$d \leq 0,34$	5 ± 2
$0,34 < d$	4 ± 2

6.4 Dimensions and tolerances

6.4.1 Tolerance on diameter

When the wire is measured in accordance with 7.2.3. The tolerance on the nominal wire diameter shall be $\pm 0,01$ mm.

6.4.2 Out of roundness

The out of roundness shall be $\leq 0,01$ mm.

6.5 Delivery conditions

6.5.1 Unit package

The wire shall be supplied in units of one single length of wire, the unit package being spools.

NOTE The recommended types of spool are given in A.1. The recommended length of wire per spool is given in A.2.

6.5.2 Welds

Welds at final size are permitted provided the weld is properly cleaned and smooth so as to permit proper processing.

The weld and heat affected zone shall have a minimum breaking force of 40 % of the minimum specified in Table 2.

6.5.3 Cast of wire

The circular cast as defined in EN 10218-1 shall be measured in accordance with EN 10218-1. Unless otherwise agreed between the purchaser and the supplier at the time of enquiry or order (see 5.2) the circular cast shall be not be less than 100 mm and not more than 250 mm.

The wap of helix cast measured in accordance with EN 10218-1:1994, 14.3.1 shall be not more than 50 mm.

7 Testing and inspection

7.1 Tests and inspection documents

Products conforming to this document shall be delivered with specific testing (see EN 10021) and the relevant inspection document in accordance with EN 10204 specified by the purchaser at the time of enquiry or order (see 5.2).

7.2 Test procedures

7.2.1 Tensile test

Tensile testing shall be carried out in accordance with EN 10218-1 and EN 10002-1 on samples comprising the full cross-section of the wire. The minimum breaking force and the elongation (A_t) at the moment of rupture shall be recorded.

7.2.2 Reverse bend test and torsion test

The test length for the torsion test shall be 100 d .

The test samples shall be subjected to a thermal ageing treatment at 150 °C for 1 h. The reverse bend tests shall be performed in accordance with EN 10218-1.

7.2.3 Diameter and out of roundness

The diameter shall be measured in accordance with EN 10218-2 using a micrometer with a precision of $\pm 0,001$ mm.

7.3 Coating mass

The coating mass shall be determined in accordance with EN 10244-1 and EN 10244-6.

7.4 Retests

Retests shall be performed in accordance with EN 10021.

8 Marking, labelling and packaging

Each spool and each unit package shall be marked with the information needed to permit traceability and reference to inspection documents.

Each spool and each unit package shall have a label attached to it bearing at least the information specified in Table 4.

Other information on the label shall be as agreed between the purchaser and the supplier.

Wire shipments shall be suitably protected against mechanical damage and/or contamination during transport.

Table 4 — Labelling information

Information	Spool	Package
Designation	+	+
Manufacturer	+	+
Identification number	+	
Heat number	(+)	
Destination		+
Order number		+
Mass (Nominal and Gross) in kilograms		+
Origin		(+)
Customer reference		+
NOTE + = mandatory; (+) = optional.		

Annex A
(informative)

Packaging of hose reinforcement wire

A.1 Recommended types of spool

Hose reinforcement wire is supplied wound on metal or plastic spools. See Figure A.1.

NOTE The arrow on the flange indicates the rotation direction for unwinding the spool.

Recommended types of spool are given in Table A.1.

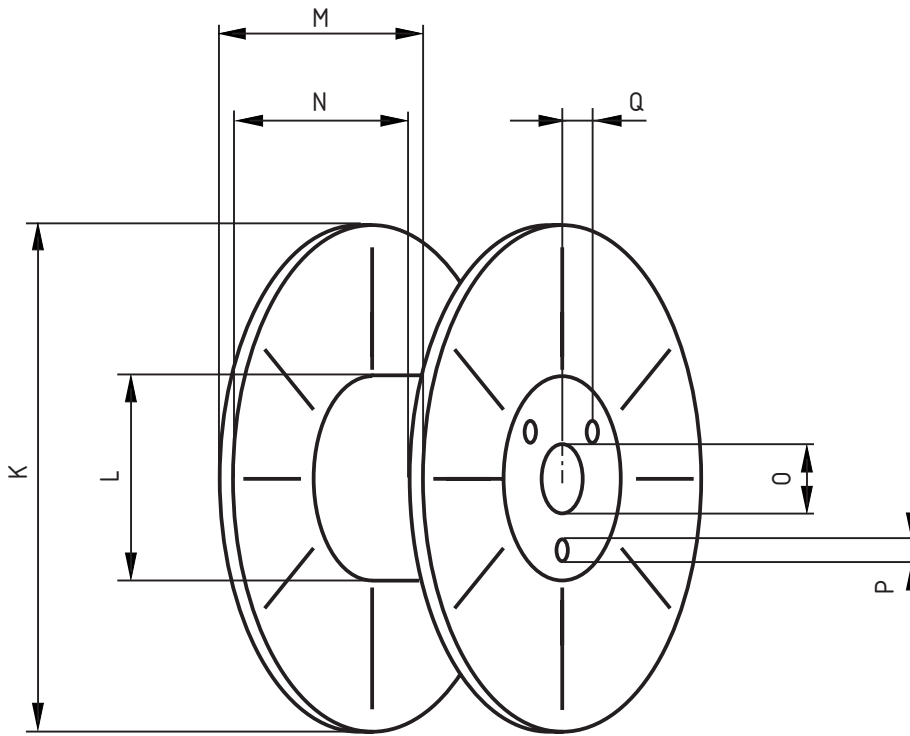

Key

- K Diameter of flange
- L Diameter of barrel
- M Overall width
- N Traverse
- O Bore
- P Number x diameter of drivehole/bore
- Q Distance of drivehole/bore

Figure A.1 — Spool for packing hose reinforcement wire

Table A.1 — Recommended types of spool

Dimensions in millimetres

	Spool type	
	BS60	BP60
Diameter of flange (K)	255	254
Diameter of barrel (L)	117	102
Overall width (M)	167	184
Tranerse (N)	153	153
Bore (O)	33	33
Number x diameter of drivehole	3 x 12,7	3 x 6
Distance drivehole/bore (Q)	43	30
Mass (kg)	1,90	1,2
Approximate wire capacity (kg)	28	28

A.2 Recommended length of wire per spool

The recommended length of hose reinforcement wire per spool is given in Table A.2.

Table A.2 — Recommended length of wire per spool

Diameter (mm)	Tensile strength range (MPa) ^a	Length per BS 60 spool (m)
0,56	2450 to 2750	15 000
0,60	2150 to 2450	14 000
0,60	2450 to 2750	14 000
0,65	2150 to 2450	11 000
0,65	2450 to 2750	11 000
0,71	2150 to 2450	9 500
0,71	2450 to 2750	9 500
0,80	2150 to 2450	7 000

^a 1MPa = 1N/mm².

BSI — British Standards Institution

BSI is the independent national body responsible for preparing British Standards. It presents the UK view on standards in Europe and at the international level. It is incorporated by Royal Charter.

Revisions

British Standards are updated by amendment or revision. Users of British Standards should make sure that they possess the latest amendments or editions.

It is the constant aim of BSI to improve the quality of our products and services. We would be grateful if anyone finding an inaccuracy or ambiguity while using this British Standard would inform the Secretary of the technical committee responsible, the identity of which can be found on the inside front cover. Tel: +44 (0)20 8996 9000. Fax: +44 (0)20 8996 7400.

BSI offers members an individual updating service called PLUS which ensures that subscribers automatically receive the latest editions of standards.

Buying standards

Orders for all BSI, international and foreign standards publications should be addressed to Customer Services. Tel: +44 (0)20 8996 9001. Fax: +44 (0)20 8996 7001. Email: orders@bsi-global.com. Standards are also available from the BSI website at <http://www.bsi-global.com>.

In response to orders for international standards, it is BSI policy to supply the BSI implementation of those that have been published as British Standards, unless otherwise requested.

Information on standards

BSI provides a wide range of information on national, European and international standards through its Library and its Technical Help to Exporters Service. Various BSI electronic information services are also available which give details on all its products and services. Contact the Information Centre. Tel: +44 (0)20 8996 7111. Fax: +44 (0)20 8996 7048. Email: info@bsi-global.com.

Subscribing members of BSI are kept up to date with standards developments and receive substantial discounts on the purchase price of standards. For details of these and other benefits contact Membership Administration. Tel: +44 (0)20 8996 7002. Fax: +44 (0)20 8996 7001. Email: membership@bsi-global.com.

Information regarding online access to British Standards via British Standards Online can be found at <http://www.bsi-global.com/bsonline>.

Further information about BSI is available on the BSI website at <http://www.bsi-global.com>.

Copyright

Copyright subsists in all BSI publications. BSI also holds the copyright, in the UK, of the publications of the international standardization bodies. Except as permitted under the Copyright, Designs and Patents Act 1988 no extract may be reproduced, stored in a retrieval system or transmitted in any form or by any means – electronic, photocopying, recording or otherwise – without prior written permission from BSI.

This does not preclude the free use, in the course of implementing the standard, of necessary details such as symbols, and size, type or grade designations. If these details are to be used for any other purpose than implementation then the prior written permission of BSI must be obtained.

Details and advice can be obtained from the Copyright & Licensing Manager. Tel: +44 (0)20 8996 7070. Fax: +44 (0)20 8996 7553. Email: copyright@bsi-global.com.