

Chemical analysis of ferrous materials — Determination of oxygen in steel and iron —

Part 1: Sampling and preparation of steel samples for oxygen determination

The European Standard EN 10276-1:2000 has the status of a
British Standard

ICS 77.080.01

ICS 77.040.30

English version

Chemical analysis of ferrous materials – Determination of
oxygen in steel and iron – Part 1: Sampling and preparation of
steel samples for oxygen determination

Analyse chimique des matériaux sidérurgiques – Dosage
de l'oxygène dans les aciers et les fontes – Partie 1:
Echantillonnage et préparation des échantillons en acier
pour dosage de l'oxygène

Chemische Analyse von Eisenmetallen – Bestimmung des
Sauerstoffgehalts von Stahl und Eisen – Teil 1: Herstellung
und Vorbereitung der Stahlproben für die Sauerstoff-
Bestimmung

This European Standard was approved by CEN on 22 April 2000.

CEN members are bound to comply with the CEN/CENELEC Internal Regulations which stipulate the conditions for giving this European Standard the status of a national standard without any alteration. Up-to-date lists and bibliographical references concerning such national standards may be obtained on application to the Central Secretariat or to any CEN member.

This European Standard exists in three official versions (English, French, German). A version in any other language made by translation under the responsibility of a CEN member into its own language and notified to the Central Secretariat has the same status as the official versions.

CEN members are the national standards bodies of Austria, Belgium, Czech Republic, Denmark, Finland, France, Germany, Greece, Iceland, Ireland, Italy, Luxembourg, Netherlands, Norway, Portugal, Spain, Sweden, Switzerland and United Kingdom.



EUROPEAN COMMITTEE FOR STANDARDIZATION
COMITÉ EUROPÉEN DE NORMALISATION
EUROPÄISCHES KOMITEE FÜR NORMUNG

Central Secretariat: rue de Stassart, 36 B-1050 Brussels

Contents

Foreword.....	3
1 Scope.....	4
2 Normative reference	4
3 Principle	4
4 Reagents.....	4
5 Apparatus.....	4
6 Sampling	5
7 Sample preparation.....	5

Foreword

This European Standard has been prepared by Technical Committee ECISS/TC 20, Methods of chemical analysis of ferrous products, the Secretariat of which is held by SIS.

This European Standard shall be given the status of a national standard, either by publication of an identical text or by endorsement, at the latest by November 2000, and conflicting national standards shall be withdrawn at the latest by November 2000.

According to the CEN/CENELEC Internal Regulations, the national standards organizations of the following countries are bound to implement this European Standard: Austria, Belgium, Czech Republic, Denmark, Finland, France, Germany, Greece, Iceland, Ireland, Italy, Luxembourg, Netherlands, Norway, Portugal, Spain, Sweden, Switzerland and the United Kingdom.

1 Scope

This European Standard specifies two methods for the preparation of steel samples for oxygen determination. Both methods are suitable for preparing samples for the determination of oxygen content, especially for oxygen contents < 0,005 0 %. This standard is applicable to steels having a hardness of < 400 HBW 10/3000.

2 Normative reference

This European Standard incorporates by dated or undated reference provisions from other publications. These normative references are cited at the appropriate places in the text and the publications are listed hereafter. For dated references, subsequent amendments to or revisions of any of these publications apply to this European Standard only when incorporated in it by amendment or revision. For undated references the latest edition of the publication referred to applies (including amendments).

ISO 14284 Steel and iron – Sampling and preparation of samples for the determination of chemical composition.

3 Principle

Samples for oxygen determination are machined to a suitable shape and size within the restrictions imposed by the instrument used. In order to ensure that the surface has the minimum possible oxygen content, samples for analysis are prepared either by punching (method A) or by turning (method B).

4 Reagents

4.1 Organic oxygen free hydrocarbon solvent, e.g. n-hexane (boiling-point range: 68 °C to 69 °C).

4.2 Argon or nitrogen.

5 Apparatus

5.1 Methods A and B

5.1.1 Mechanical steel saw.

5.1.2 Tweezers.

5.1.3 Receptacles for storing the test samples, e.g. glass tubes about 2,5 cm long and about 1 cm in diameter with stoppers/caps.

5.2 Method A:

5.2.1 Punch: suitable for punching out samples in the manner described in 7.1.4.

Purging by argon or nitrogen ensures minimum possible contact of the samples with atmospheric oxygen. This is illustrated in Figure 1.

5.2.2 Flat bed finisher for finishing the steel sample.

5.2.3 Electrical hand drill and rotary file, with rotation speed exceeding 30 000 rev/min.

5.3 Method B:

- 5.3.1 Lathe for turning steel samples at speeds of 250 rev/min to 1 200 rev/min.
- 5.3.2 Hand saw: the saw blade shall be free from grease or paint.
- 5.3.3 Filing block made of stainless steel which holds the samples firm during filing of the end-faces (Figure 2).
- 5.3.4 Hand files: cut no. 4.
- 5.3.5 Metal wire brush with strong bristles about 2 cm long.

6 Sampling

Sampling for preparation of the analytical samples shall proceed in accordance with ISO 14284.

The distribution of oxygen within the product is dependent on the manufacturing process. The result of the oxygen determination will therefore depend on the sample position. This has to be agreed if it is not specified in the product standard.

7 Sample preparation

7.1 Method A Punching

- 7.1.1 Saw off slices 3 mm to 4 mm thick from the sample piece using a mechanical saw (5.1.1). The number shall be as required by the method.

NOTE: Figures 3 and 4 give examples of the different procedures for different sample shapes.

- 7.1.2 Use a flat bed finisher (5.2.2) with 60 grade silicon carbide paper so that the sample slices are ground flat on both sides removing most of the oxide layer. Hold the sample with a magnetic holding device during grinding.
- 7.1.3 Remove thoroughly any oxides remaining on the surface with a rotary file under a flow of argon or nitrogen (5.2.3). The condition of the surface after preparation shall be smooth, bright and free from burrs and irregularities. Avoid significant heating of the sample in order to prevent oxidation of the surface after removal from inert atmosphere.

After treatment, handle the samples with tweezers only. Do not touch the samples by hand.

NOTE: During milling and all subsequent preparations, take care to ensure that the tools and objects coming into contact with the sample are free from oxygen containing contaminants.

- 7.1.4 The test samples should usually have a mass of approximately 1 g. The mass of the sample depends on the method of oxygen determination. Prepare the samples with a punch (5.2.1). A punch of 4 to 6 mm diameter is normally suitable for this purpose. During the punching operation purge the receptacle into which the sample is collected, with argon or nitrogen (4.2) (Figure 1). Keep the test samples in a glass receptacle (5.1.3). Samples should be analyzed as soon as possible on the same day as preparation.
- 7.1.5 Immediately before analysis, wash the test samples in organic solvent (4.1) and dry them in air or under vacuum free from backgassing.

NOTE: Problems with microcracks have been encountered in the determination of low levels of carbon (< 10 ppm). There may be similar contamination problems in the determination of oxygen.

7.2 Method B Turning

7.2.1 Take rectangular pieces about 100 mm long with a cross section of about 10 mm × 10 mm from the sample piece with a mechanical saw. Figures 3 and 4 give examples of the various procedures for different shapes of samples.

If rods, wire or forged pieces of about 10 mm diameter are available, it is only necessary to cut off one piece about 100 mm in length.

7.2.2 The test samples should usually have a mass of approximately 1 g. The mass of the sample depends on the method of oxygen determination. Prepare these samples by turning the pieces on a lathe (5.3.1). For this purpose, turn down the sample obtained in accordance with 7.2.1, to about 7 mm diameter at a speed of about 1 000 rev/min. Subsequent turning down to 6 mm diameter shall be at a speed of 250 rev/min with a feed of about 0,2 mm/rev. After turning, file the surface with a fine file (5.3.4) with the lathe still running until the sample is smooth and bright. Avoid significant heating of the sample in order to prevent oxidation of the surface.

As an alternative to slow-speed turning, reduce the diameter from 7 mm to 6 mm using a speed of between 800 rev/min to 1 000 rev/min and a feed of between 0,1 to 0,15 mm/rev. In this case, the cylindrical surface is smooth enough to dispense with the filing operation.

NOTE: Use no cooling lubricant during turning down from 7 mm to 6 mm. Take care also during the subsequent stages in preparation to ensure that any objects coming into contact with the sample are free from oxygen containing contaminants.

7.2.3 Using the hand saw (5.3.2), saw off the end of the sample which is not used for analysis. Clean the accessible end face of the clamped sample by filing. Then, saw off a test sample 4 mm to 5 mm long for analysis.

Handle the sample with tweezers only. Do not touch samples by hand. Use the tweezers for all manipulations. File carefully the unfiled end face of the sample in a filing block (Figure 2) or in another similar holding device. Remove carefully any adhering dust with a small brush (5.3.5). Keep the test samples in a glass receptacle (5.1.3). These shall be analyzed as soon as possible on the same day as they were prepared.

Immediately before analysis, wash the samples in organic solvent (4.1) and dry them in air or under vacuum free from backgassing.

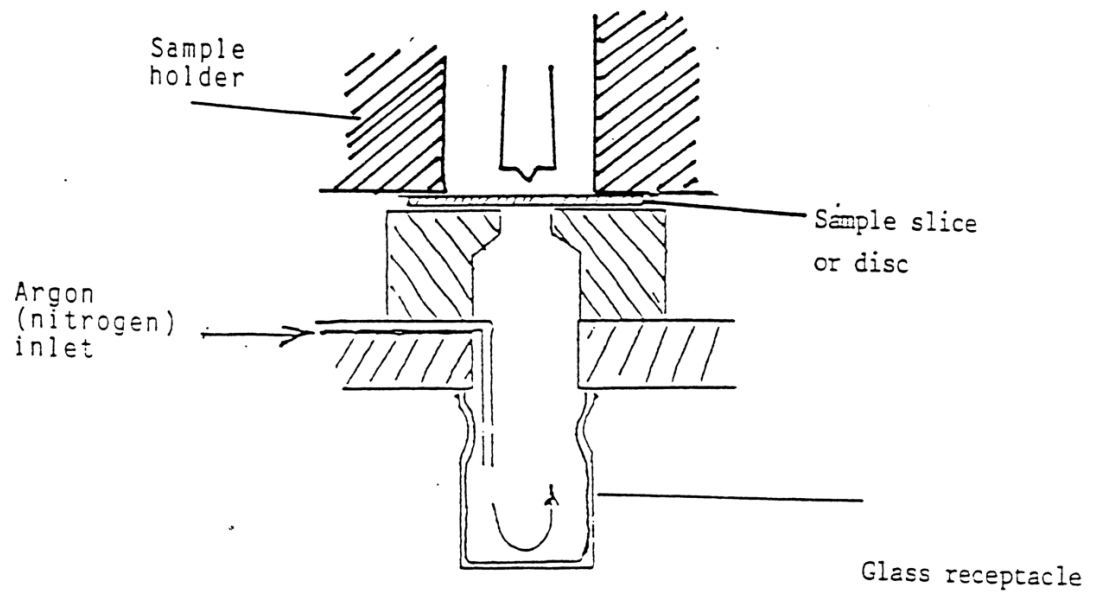

Figure 1 - Punch for making samples for oxygen analysis

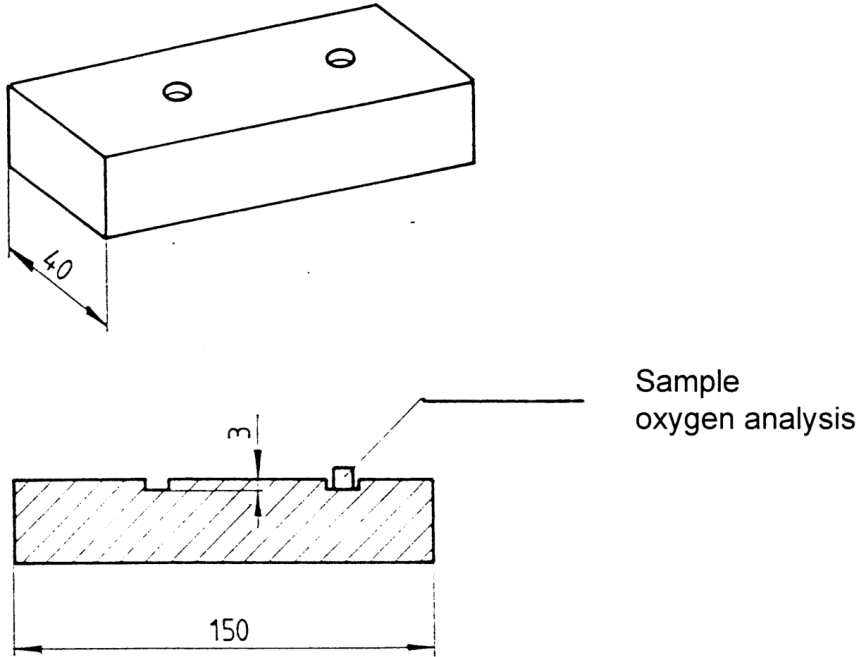
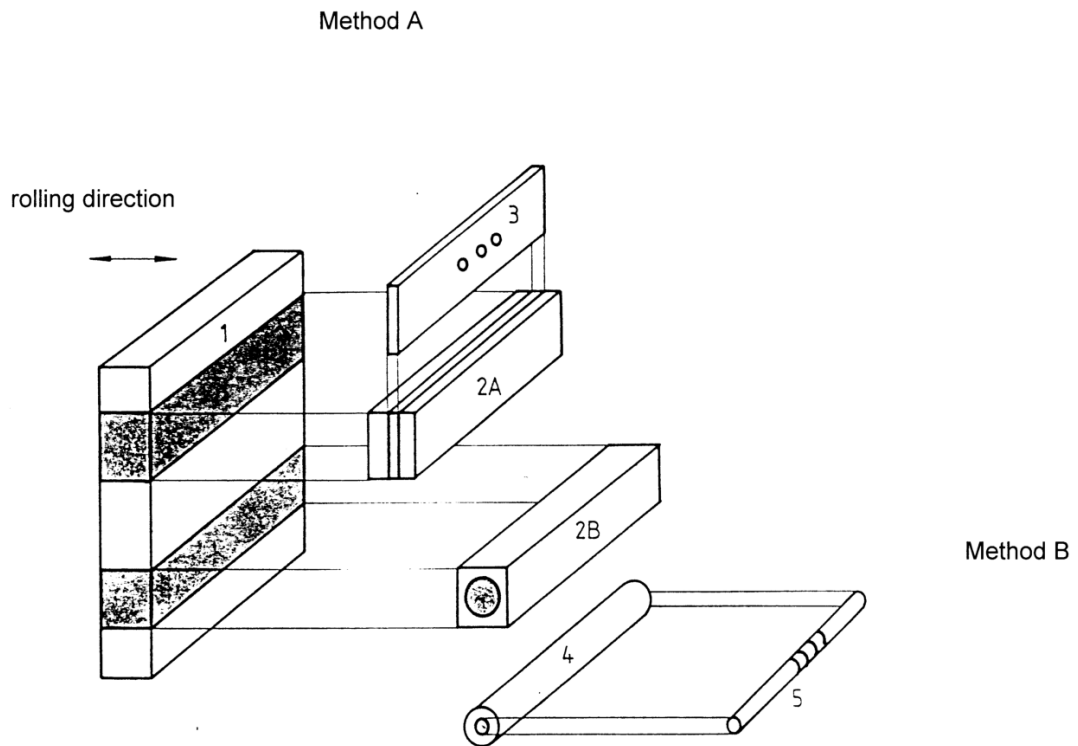

Figure 2 - Filing block



1. Sample piece.
- 2A and 2B. Sections sawn out of the sample piece.
3. Sawn-out sample slice; the shaded circles denote the positions at which the samples can be punched out.
4. Produced from 2B by turning.
5. Produced by turning, from which the test samples (shaded zones) are sawn.

Figure 3 - Example of production of test samples from a sample piece

Method A

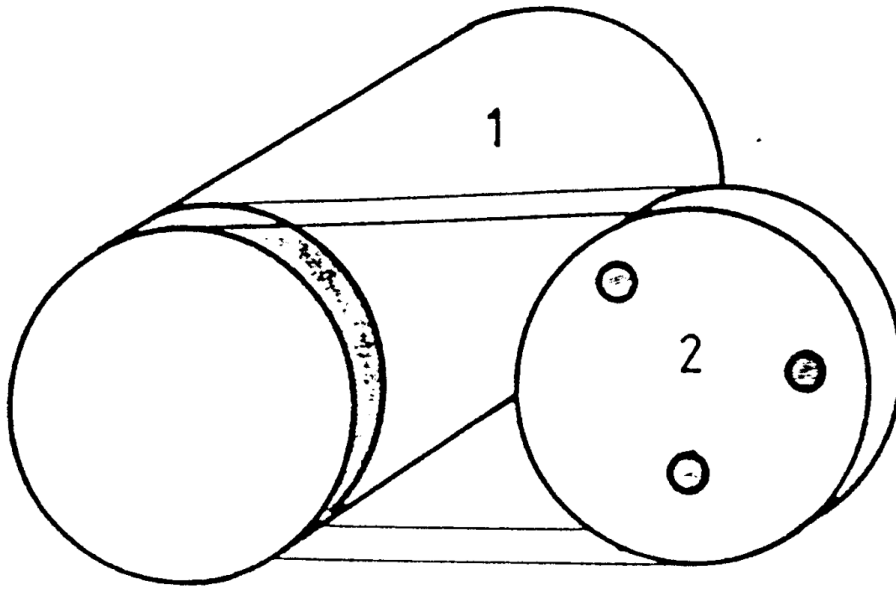

Method B

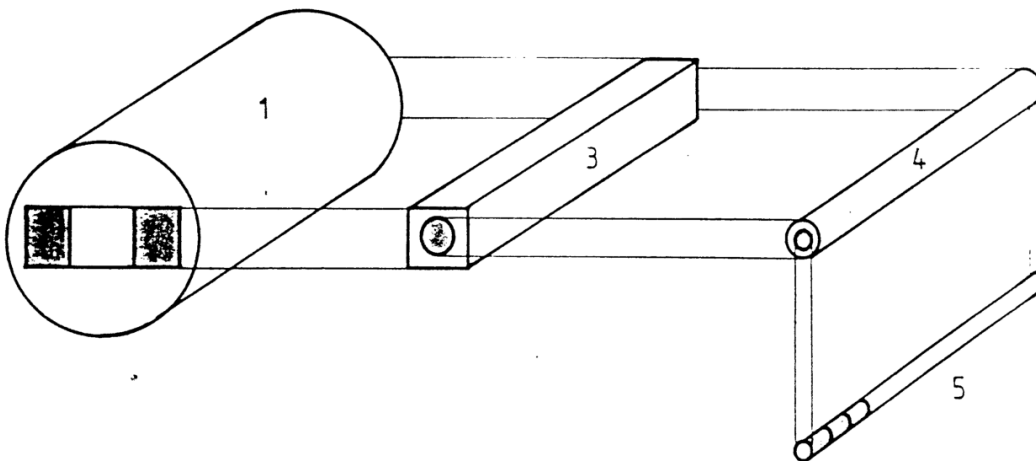

1. Sample piece.
2. Sample slice/disc sawn off. The shaded circles denote the positions at which the samples can be punched out.
3. Bar sawn out of the sample piece.
4. Bar produced from (3) by turning.
5. Bar produced by turning down from which the test samples (indicated by shading) can be sawn.

Figure 4 - Example of production of test samples from a sample piece

BSI — British Standards Institution

BSI is the independent national body responsible for preparing British Standards. It presents the UK view on standards in Europe and at the international level. It is incorporated by Royal Charter.

Revisions

British Standards are updated by amendment or revision. Users of British Standards should make sure that they possess the latest amendments or editions.

It is the constant aim of BSI to improve the quality of our products and services. We would be grateful if anyone finding an inaccuracy or ambiguity while using this British Standard would inform the Secretary of the technical committee responsible, the identity of which can be found on the inside front cover. Tel: 020 8996 9000. Fax: 020 8996 7400.

BSI offers members an individual updating service called PLUS which ensures that subscribers automatically receive the latest editions of standards.

Buying standards

Orders for all BSI, international and foreign standards publications should be addressed to Customer Services. Tel: 020 8996 9001. Fax: 020 8996 7001.

In response to orders for international standards, it is BSI policy to supply the BSI implementation of those that have been published as British Standards, unless otherwise requested.

Information on standards

BSI provides a wide range of information on national, European and international standards through its Library and its Technical Help to Exporters Service. Various BSI electronic information services are also available which give details on all its products and services. Contact the Information Centre. Tel: 020 8996 7111. Fax: 020 8996 7048.

Subscribing members of BSI are kept up to date with standards developments and receive substantial discounts on the purchase price of standards. For details of these and other benefits contact Membership Administration. Tel: 020 8996 7002. Fax: 020 8996 7001.

Copyright

Copyright subsists in all BSI publications. BSI also holds the copyright, in the UK, of the publications of the international standardization bodies. Except as permitted under the Copyright, Designs and Patents Act 1988 no extract may be reproduced, stored in a retrieval system or transmitted in any form or by any means – electronic, photocopying, recording or otherwise – without prior written permission from BSI.

This does not preclude the free use, in the course of implementing the standard, of necessary details such as symbols, and size, type or grade designations. If these details are to be used for any other purpose than implementation then the prior written permission of BSI must be obtained.

If permission is granted, the terms may include royalty payments or a licensing agreement. Details and advice can be obtained from the Copyright Manager. Tel: 020 8996 7070.