

Non-destructive testing of steel tubes —

Part 4: Automatic full peripheral magnetic transducer/flux leakage testing of seamless ferromagnetic steel tubes for the detection of transverse imperfections

The European Standard EN 10246-4:1999 has the status of a
British Standard

ICS 23.040.10; 77.040.20

National foreword

This British Standard is the official English language version of EN 10246-4:1999.

This British Standard contains elements of BS 3889-1:1983. A complete list of the parts of EN 10246 is given in annex A of this standard. This British Standard partially supersedes BS 3889-1:1983, and when all relevant parts have been published BS 3889-1:1983 will be withdrawn.

The UK participation in its preparation was entrusted by Technical Committee ISE/73, Steels for pressure purposes, to Subcommittee ISE/73/1, Steel tubes for pressure purposes, which has the responsibility to:

- aid enquirers to understand the text;
- present to the responsible European committee any enquiries on the interpretation, or proposals for change, and keep the UK interests informed;
- monitor related international and European developments and promulgate them in the UK.

A list of organizations represented on this subcommittee can be obtained on request to its secretary.

Cross-references

The British Standards which implement international or European publications referred to in this document may be found in the BSI Standards Catalogue under the section entitled “International Standards Correspondence Index”, or by using the “Find” facility of the BSI Standards Electronic Catalogue.

A British Standard does not purport to include all the necessary provisions of a contract. Users of British Standards are responsible for their correct application.

Compliance with a British Standard does not of itself confer immunity from legal obligations.

Summary of pages

This document comprises a front cover, an inside front cover, the EN title page, pages 2 to 12, an inside back cover and a back cover.

The BSI copyright notice displayed in this document indicates when the document was last issued.

Amendments issued since publication

Amd. No.	Date	Comments

This British Standard, having been prepared under the direction of the Engineering Sector Committee, was published under the authority of the Standards Committee and comes into effect on 15 February 2000

© BSI 02-2000

ISBN 0 580 35435 0

ICS 23.040.10; 77.040.20

English version

Non-destructive testing of steel tubes – Part 4: Automatic full peripheral magnetic transducer/flux leakage testing of seamless ferromagnetic steel tubes for the detection of transverse imperfections

Essais non destructifs des tubes en acier – Partie 4:
Contrôle automatique par flux de fuite à l'aide de palpeurs magnétiques sur toute la circonférence des tubes pour la détection des imperfections transversales des tubes en aciers ferromagnétiques sans soudure

Zerstörungsfreie Prüfung von Stahlrohren – Teil 4:
Automatische Magnetfeldsonden-Streuflußprüfung nahtloser ferromagnetischer Stahlrohre über den gesamten Rohrumfang zum Nachweis von Querfehlern

This European Standard was approved by CEN on 6 October 1999.

CEN members are bound to comply with the CEN/CENELEC Internal Regulations which stipulate the conditions for giving this European Standard the status of a national standard without any alteration. Up-to-date lists and bibliographical references concerning such national standards may be obtained on application to the Central Secretariat or to any CEN member.

This European Standard exists in three official versions (English, French, German). A version in any other language made by translation under the responsibility of a CEN member into its own language and notified to the Central Secretariat has the same status as the official versions.

CEN members are the national standards bodies of Austria, Belgium, Czech Republic, Denmark, Finland, France, Germany, Greece, Iceland, Ireland, Italy, Luxembourg, Netherlands, Norway, Portugal, Spain, Sweden, Switzerland and United Kingdom.



EUROPEAN COMMITTEE FOR STANDARDIZATION
COMITÉ EUROPÉEN DE NORMALISATION
EUROPÄISCHES KOMITEE FÜR NORMUNG

Central Secretariat: rue de Stassart, 36 B-1050 Brussels

Contents

Page

Foreword	3
1 Scope	4
2 General requirements	4
3 Method of test	4
4 Reference standards	5
5 Equipment calibration and checking	9
6 Acceptance	10
7 Test reporting	10
Annex A (informative) Table of Parts of EN 10246 - Non-destructive testing of steel tubes	11
Annex B (informative) Guidelines notes on limitations associated with the transducer/flux leakage test method	12

Foreword

This European Standard has been prepared by Technical Committee ECISS/TC 29 "Steel tubes and fittings for steel tubes", the Secretariat of which is held by UNI.

This European Standard shall be given the status of a national standard, either by publication of an identical text or by endorsement, at the latest by May 2000, and conflicting national standards shall be withdrawn at the latest by May 2000.

This European Standard has been prepared under a mandate given to CEN by the European Commission and the European Free Trade Association. This European Standard is considered to be a supporting standard to those application and product standards which in themselves support an essential safety requirement of a New Approach Directive and which make reference to this European Standard.

According to the CEN/CENELEC Internal Regulations, the national standards organizations of the following countries are bound to implement this European Standard: Austria, Belgium, Czech Republic, Denmark, Finland, France, Germany, Greece, Iceland, Ireland, Italy, Luxembourg, Netherlands, Norway, Portugal, Spain, Sweden, Switzerland and the United Kingdom.

1 Scope

This Part of EN 10246 specifies the requirements for automatic full peripheral magnetic transducer/flux leakage testing of seamless ferromagnetic steel tubes for the detection of transverse imperfections. The standard specifies acceptance levels, calibration procedures and gives guidance on the limitations of the tests.

This Part of EN 10246 is applicable to the inspection of tubes with an outside diameter equal to or greater than 10 mm.

European Standard EN 10246 "Non-destructive testing of steel tubes" comprises the Parts shown in annex A.

2 General requirements

2.1 The magnetic transducer/flux leakage inspection covered by this Part of EN 10246 is usually carried out on tubes after completion of all the primary production process operations.

2.2 The tubes to be tested shall be sufficiently straight and free from foreign matter as to ensure the validity of the test.

3 Method of test

3.1 The tubes shall be tested using a magnetic transducer/flux leakage technique for the detection of predominantly transverse imperfections (see figure 1). No limits on thickness are specified: The effectiveness of the technique decreases with increasing thickness (see annex B).

It is recognized that there may be a short length at both tube ends which cannot be tested. Any untested ends shall be dealt with in accordance with the requirements of the appropriate product standards.

3.2 When testing, the tube and the transducer shall be moved relative to each other so that the whole of the tube surface is scanned.

The relative speed during testing shall not vary by more than $\pm 10\%$.

3.3 The maximum width of each individual transducer, measured at right angles to the major axis of the tube shall be 30 mm.

3.4 The equipment shall be capable of classifying tubes as either acceptable or suspect tubes by means of an automatic trigger/alarm level combined with a marking and/or sorting system.

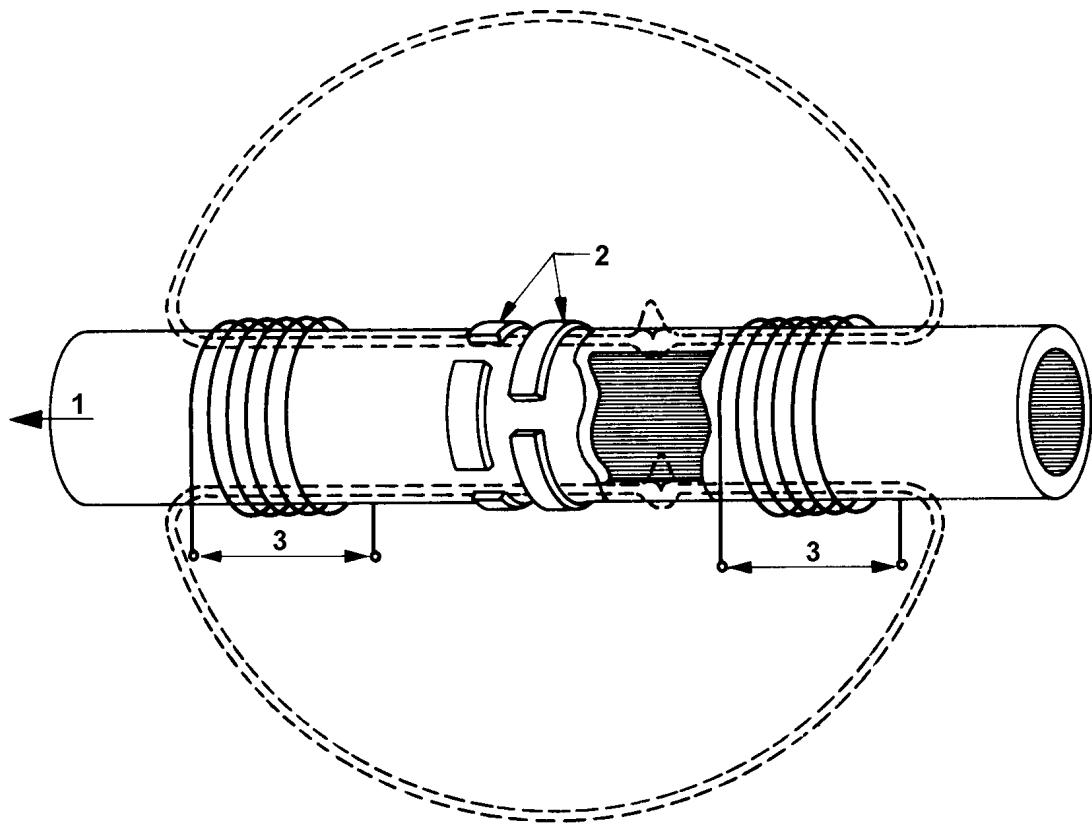

1= direction of tube movement 2= staggered array of transducers

3= direct voltage

NOTE: The magnetic transducer array in the above diagram may take different forms, for example absolute, differential, depending on the equipment used and other factors. The means of introducing magnetic flux in a direction parallel to the major axis of the tube can be achieved by methods other than that shown above.

Figure 1: Simplified diagram of typical magnetic transducer/flux leakage technique

4 Reference standards

4.1 General

4.1.1 The reference standards defined in this Part of EN 10246 are convenient standards for calibration of non-destructive testing equipment. The dimensions of these standards should not be construed as the minimum size of imperfections detectable by such equipment.

4.1.2 The magnetic transducer/flux leakage equipment shall be calibrated using a transverse reference notch on the outside and inside surfaces, or the outside surface only (see note below) of a tubular test piece.

Alternatively, a circular reference hole drilled radially through the full thickness of the test piece may be used for equipment calibration by agreement between the purchaser and the manufacturer.

In this case the diameter of the drill required to produce the reference hole for a specific acceptance level shall be agreed upon and the manufacturer shall demonstrate that the test sensitivity achieved using the reference hole and the equipment settings, for example filtering, is essentially equivalent to that obtained when using the specified external reference notch and the agreed internal reference notch depth.

The diameter of the reference hole, when used, shall be verified and shall not exceed the agreed drill diameter by more than 0,2 mm.

NOTE: The internal surface of the test piece may be dressed or machined prior to the preparation of the internal notch.

The internal notch should not be used when the tube internal diameter is less than 20 mm, unless otherwise agreed between the purchaser and the manufacturer, or when the tube thickness is greater than 20 mm since, due to technical limitations given in annex B, the test at the tube bore is not adequate even after applying the maximum ratios given in table B1.

4.1.3 The test piece shall be of the same specified diameter, thickness, surface finish and heat treatment conditions as the tube to be tested and shall have similar electromagnetic properties.

4.1.4 The external and internal notches and reference hole shall be sufficiently separated from the ends of the test piece and from each other (when both notches are used), so that clearly distinguishable signal indications are obtained.

4.2 Types of reference notches

4.2.1 The reference notches shall be of the "N" type (see figure 2) and shall be transverse to the major axis of the tube. The sides shall be nominally parallel and the bottom shall be nominally square to the sides.

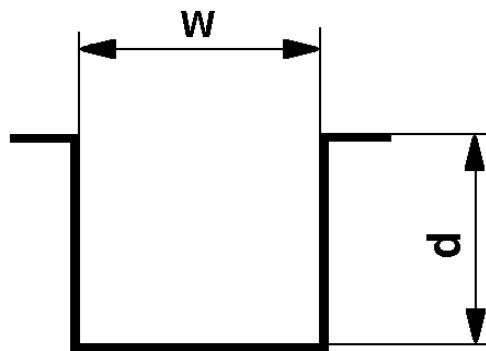

w = width d = depth

Figure 2: "N" type notch

4.2.2 The reference notch shall be formed by machining, spark erosion or other methods.

NOTE: It is recognized that the bottom or the bottom corners of the notch may be rounded.

4.2.3 The notches normally used shall be as shown in figures 3(a) and 3(b). The notches shown in figures 3 (c), 3(d) and 3(e) may be used at the discretion of the manufacturer.

4.3 Dimensions of reference notch

4.3.1 The width, w (see figure 2), of the reference notch shall not be greater than twice the depth of the reference notch, with a maximum of 1 mm.

4.3.2 The depth, d (see figure 2), of the reference notch shall be as follows:

- a) the external notch depth shall be as given in table 1 with the following limitations:
 - minimum notch depth: 0,3 mm for F2 and F3 category and 0,5 mm for F4, F5 and F6 category tubes;
 - maximum notch depth: 1,5 mm;
- b) the internal notch depth shall be subject to agreement between purchaser and manufacturer (see annex B) but in no circumstance shall be less than the specified external notch depth or greater than that applying the maximum ratios given in table B1; the maximum internal notch depth shall be 3,0 mm.

Table 1: Acceptance level designation and corresponding external reference notch depth

Acceptance level	Notch depth in % of the specified thickness (see note)
F2	5
F3	10
F4	12,5
F5	15
F6	20

Note. The values of notch depth specified in this table are the same for the corresponding categories, in all European Standards concerning non-destructive testing of steel tubes where reference is made to different acceptance levels. It should, however, be kept in mind that although the reference standards are identical, the various test methods involved can give different test results. Accordingly the acceptance level designation prefix F (flux leakage) has been adopted to avoid any inferred direct equivalence with other test methods.

4.3.3 The tolerance on notch depth shall be $\pm 15\%$ of the reference notch depth or $\pm 0,05$ mm whichever is the larger.

4.3.4 The length of the reference notch, as far as it is not specified by the type of notch (chord notch, arc notch - see figures 3c) to 3e)), shall be at least 25 mm.

4.4 Verification of reference notch

The reference notch dimensions and shape shall be verified by a suitable technique.

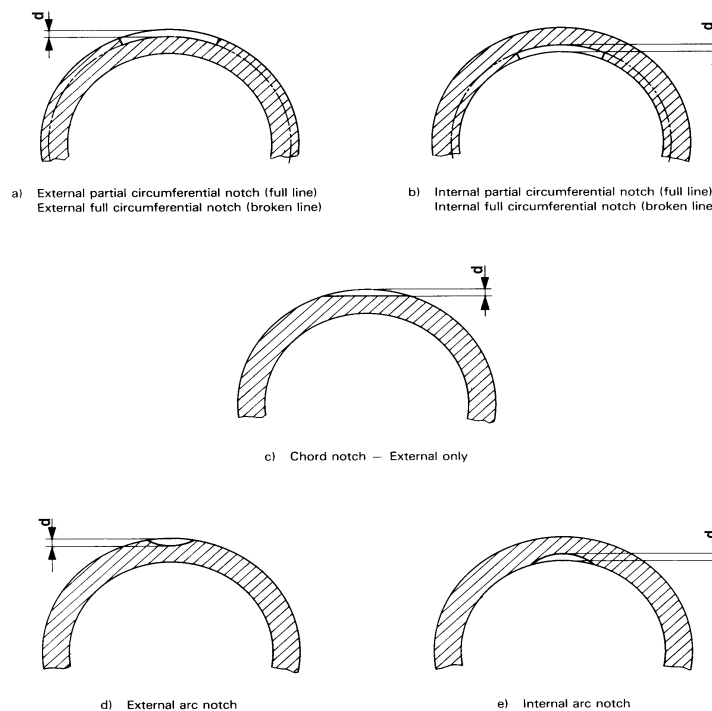

Figure 3: Transverse notch forms

5 Equipment calibration and checking

5.1 The equipment shall be calibrated to produce consistently, (e.g. from three consecutive passes of the test piece through the equipment), clearly identifiable signals from the reference standard(s). These signals shall be used to set the trigger/alarm level of the equipment.

5.2 During the calibration check, the relative speed of movement between the test piece and the transducer assembly shall be the same as that to be used during production test. Semi-dynamic calibration checking may be used. When requested the manufacturer shall demonstrate that the semi-dynamic calibration check gives the same results as for the dynamic calibration check.

5.3 The calibration of the equipment shall be checked at regular intervals during the production testing of tubes of the same specified diameter, thickness and grade by passing the test piece through the test equipment.

The frequency of checking the calibration shall be at least every four hours but also whenever there is an equipment operator team changeover and at the start and end of production.

5.4 The equipment shall be recalibrated if any of the parameters which were used during the initial calibration are changed.

5.5 If on checking during production testing the calibration requirements are not satisfied, even after increasing the test sensitivity by 3 dB to allow for system drift, then all tubes tested since the previous check shall be retested after the equipment has been recalibrated.

6 Acceptance

6.1 Any tube producing signals lower than the trigger/alarm level shall be deemed to have passed this test.

6.2 Any tube producing signals equal to or greater than the trigger/alarm level shall be designated suspect, or at the manufacturer's option, may be retested.

6.3 If on retesting, no signals are obtained equal to or greater than trigger/alarm level, the tube shall be deemed to have passed this test.

Tubes giving signals equal to or greater than trigger/alarm level shall be designated suspect.

6.4 For suspect tubes, one or more of the following actions shall be taken subject to the requirements of the product standard:

a) The suspect area shall be dressed or explored by a suitable method. After checking that the remaining thickness is within tolerance, the tube shall be tested as previously specified. If no signals are obtained equal to or greater than trigger/alarm level, the tube shall be deemed to have passed this test.

The suspect area may be retested by other non-destructive techniques and test methods, by agreement between the purchaser and manufacturer to agreed acceptance levels.

b) The suspect area shall be cropped off. The manufacturer shall ensure that all the suspect area has been removed.

c) The tube shall be deemed not to have passed the test.

7 Test reporting

When specified, the manufacturer shall submit to the purchaser a test report containing at least the following information:

- a) reference to this Part of EN 10246;
- b) date of test report;
- c) acceptance level;
- d) statement of conformity;
- e) product designation by grade and size;
- f) type and details of inspection technique;
- g) description of the reference standard.

Annex A
(informative)
Table of Parts of EN 10246 - Non-destructive testing of steel tubes

Purpose of test	Title of Part	Part no.	ISO ref.
Leak tightness	Automatic electromagnetic testing of seamless and welded (except submerged arc-welded) ferromagnetic steel tubes for verification of hydraulic leak-tightness.	1	9302
	Automatic eddy current testing of seamless and welded (except submerged arc-welded) austenitic and austenitic-ferritic steel tubes for verification of hydraulic leak-tightness.	2	-
Longitudinal and/or transverse imperfections	Automatic eddy current testing of seamless and welded (except submerged arc-welded) steel tubes for the detection of imperfections	3	9304
	Automatic full peripheral magnetic transducer/flux leakage testing of seamless ferromagnetic steel tubes for the detection of transverse imperfections	4	9598
	Automatic full peripheral magnetic transducer/flux leakage testing of seamless and welded (except submerged arc-welded) ferromagnetic steel tubes for the detection of longitudinal imperfections	5	9402
	Automatic full peripheral ultrasonic testing of seamless steel tubes for the detection of transverse imperfections.	6	9305
	Automatic full peripheral ultrasonic testing of seamless and welded (except submerged arc-welded) steel tubes for the detection of longitudinal imperfections.	7	9303
	Automatic ultrasonic testing of the weld seam of electric welded steel tubes for the detection of longitudinal imperfections.	8	9764
	Automatic ultrasonic testing of the weld seam of submerged arc-welded steel tubes for the detection of longitudinal and/or transverse imperfections.	9	9765
	Radiographic testing of the weld seam of automatic fusion arc welded steel tubes for the detection of imperfections	10	12096
Surface imperfections	Liquid penetrant testing of seamless and welded steel tubes for the detection of surface imperfections.	11	12095
	Magnetic particle inspection of seamless and welded ferromagnetic steel tubes for the detection of surface imperfections	12	13665
Thickness	Automatic full peripheral ultrasonic thickness testing of seamless and welded (except submerged arc-welded) steel tubes.	13	10543
Laminar imperfections	Automatic ultrasonic testing of seamless and welded (except submerged arc-welded) steel tubes for the detection of laminar imperfections.	14	10124
	Automatic ultrasonic testing of strip/plate used in the manufacture of welded steel tubes for the detection of laminar imperfections.	15	12094
	Automatic ultrasonic testing of the areas adjacent to the weld seam of welded steel tubes for the detection of laminar imperfections.	16	13663
	Ultrasonic testing of the tube ends of seamless and welded steel tubes for the detection of laminar imperfections	17	11496
	Magnetic particle inspection of the tube ends of seamless and welded ferromagnetic steel tubes for the detection of laminar imperfections.	18	13664

Annex B
 (informative)

Guidelines notes on limitations associated with the transducer/flux leakage test method

It should be noted that during the magnetic transducer/flux leakage testing of tubes, the test sensitivity is at its maximum on the tube surface adjacent to the magnetic transducer and decreases with increasing distance from the tube surface due to effective diminishing flux diversion from imperfection at the tube bore surface in relation to that at the external surface. The signal response from an internal surface imperfection may thus be smaller than that from an external imperfection of the same size.

As a result, it is necessary for the internal notch depth to be increased in excess of that specified for the external notch depth by an amount to be agreed between the purchaser and the manufacturer, dependant on for example the type of equipment in use and the surface condition of the tube to be tested but generally in accordance with table B1.

Table B.1: Maximum ratio of internal and external notch depth with respect to tube thickness

Specified wall thickness T mm	Maximum ratio $\frac{\text{internal notch depth}}{\text{external notch depth}}$	
	F2	F3/F4/F5/F6
$4 < T \leq 12$	2,0 ¹⁾	1,2
$12 < T \leq 15$	2,5	1,5
$15 < T \leq 20$	3,0	2,0

1) Minimum internal notch depth: 0,4 mm

BSI — British Standards Institution

BSI is the independent national body responsible for preparing British Standards. It presents the UK view on standards in Europe and at the international level. It is incorporated by Royal Charter.

Revisions

British Standards are updated by amendment or revision. Users of British Standards should make sure that they possess the latest amendments or editions.

It is the constant aim of BSI to improve the quality of our products and services. We would be grateful if anyone finding an inaccuracy or ambiguity while using this British Standard would inform the Secretary of the technical committee responsible, the identity of which can be found on the inside front cover. Tel: 020 8996 9000. Fax: 020 8996 7400.

BSI offers members an individual updating service called PLUS which ensures that subscribers automatically receive the latest editions of standards.

Buying standards

Orders for all BSI, international and foreign standards publications should be addressed to Customer Services. Tel: 020 8996 9001. Fax: 020 8996 7001.

In response to orders for international standards, it is BSI policy to supply the BSI implementation of those that have been published as British Standards, unless otherwise requested.

Information on standards

BSI provides a wide range of information on national, European and international standards through its Library and its Technical Help to Exporters Service. Various BSI electronic information services are also available which give details on all its products and services. Contact the Information Centre. Tel: 020 8996 7111. Fax: 020 8996 7048.

Subscribing members of BSI are kept up to date with standards developments and receive substantial discounts on the purchase price of standards. For details of these and other benefits contact Membership Administration. Tel: 020 8996 7002. Fax: 020 8996 7001.

Copyright

Copyright subsists in all BSI publications. BSI also holds the copyright, in the UK, of the publications of the international standardization bodies. Except as permitted under the Copyright, Designs and Patents Act 1988 no extract may be reproduced, stored in a retrieval system or transmitted in any form or by any means – electronic, photocopying, recording or otherwise – without prior written permission from BSI.

This does not preclude the free use, in the course of implementing the standard, of necessary details such as symbols, and size, type or grade designations. If these details are to be used for any other purpose than implementation then the prior written permission of BSI must be obtained.

If permission is granted, the terms may include royalty payments or a licensing agreement. Details and advice can be obtained from the Copyright Manager. Tel: 020 8996 7070.