

BS EN 10228-1:2016



BSI Standards Publication

Non-destructive testing of steel forgings

Part 1: Magnetic particle inspection

National foreword

This British Standard is the UK implementation of EN 10228-1:2016. It supersedes BS EN 10228-1:1999 which is withdrawn.

The UK participation in its preparation was entrusted to Technical Committee ISE/111, Steel Castings and Forgings.

A list of organizations represented on this committee can be obtained on request to its secretary.

This publication does not purport to include all the necessary provisions of a contract. Users are responsible for its correct application.

© The British Standards Institution 2016. Published by BSI Standards Limited 2016

ISBN 978 0 580 80529 5

ICS 77.040.20; 77.140.85

Compliance with a British Standard cannot confer immunity from legal obligations.

This British Standard was published under the authority of the Standards Policy and Strategy Committee on 30 June 2016.

Amendments issued since publication

Date	Text affected
------	---------------

EUROPEAN STANDARD

EN 10228-1

NORME EUROPÉENNE

EUROPÄISCHE NORM

June 2016

ICS 77.040.20; 77.140.85

Supersedes EN 10228-1:1999

English Version

Non-destructive testing of steel forgings - Part 1: Magnetic particle inspection

Essais non destructifs des pièces forgées - Partie 1 :
Contrôle par magnétoscopie

Zerstörungsfreie Prüfung von Schmiedestücken aus
Stahl - Teil 1: Magnetpulverprüfung

This European Standard was approved by CEN on 3 October 2015.

CEN members are bound to comply with the CEN/CENELEC Internal Regulations which stipulate the conditions for giving this European Standard the status of a national standard without any alteration. Up-to-date lists and bibliographical references concerning such national standards may be obtained on application to the CEN-CENELEC Management Centre or to any CEN member.

This European Standard exists in three official versions (English, French, German). A version in any other language made by translation under the responsibility of a CEN member into its own language and notified to the CEN-CENELEC Management Centre has the same status as the official versions.

CEN members are the national standards bodies of Austria, Belgium, Bulgaria, Croatia, Cyprus, Czech Republic, Denmark, Estonia, Finland, Former Yugoslav Republic of Macedonia, France, Germany, Greece, Hungary, Iceland, Ireland, Italy, Latvia, Lithuania, Luxembourg, Malta, Netherlands, Norway, Poland, Portugal, Romania, Slovakia, Slovenia, Spain, Sweden, Switzerland, Turkey and United Kingdom.



EUROPEAN COMMITTEE FOR STANDARDIZATION
COMITÉ EUROPÉEN DE NORMALISATION
EUROPÄISCHES KOMITEE FÜR NORMUNG

CEN-CENELEC Management Centre: Avenue Marnix 17, B-1000 Brussels

Contents	Page
European foreword.....	3
1 Scope	4
2 Normative references	4
3 Items for agreement.....	4
4 Test procedure	5
4.1 General.....	5
4.2 Description	5
4.3 Content.....	5
5 Personnel qualification.....	6
6 Testing system.....	6
6.1 Magnetizing equipment	6
6.2 Detection media.....	6
6.3 Function checks	6
7 Stage of manufacture	6
8 Surface condition	7
8.1 General.....	7
8.2 Surface condition related to quality class	7
8.3 As-forged surface condition	7
9 Coverage	7
10 Magnetization	7
10.1 Direction of magnetization	7
10.2 Current waveform.....	8
10.3 Flux density and field strength.....	8
11 Use of detection media	8
12 Viewing conditions	8
13 Classification of indications	9
14 Recording and acceptance criteria	10
15 Removal of defects.....	11
16 Demagnetization	11
17 Test report.....	11
Annex A (normative) Magnetization using prods or electromagnetic yoke	13
A.1 Definition of tested area with prods or yoke	13
A.2 Definition of search pattern and examination sequence.....	14
Annex B (informative) Significant technical changes to the version EN 10228-1:1999.....	15

European foreword

This document (EN 10228-1:2016) has been prepared by Technical Committee ECISS/TC 111 “Steel castings and forgings”, the secretariat of which is held by AFNOR.

This European Standard shall be given the status of a national standard, either by publication of an identical text or by endorsement, at the latest by December 2016 and conflicting national standards shall be withdrawn at the latest by December 2016.

Attention is drawn to the possibility that some of the elements of this document may be the subject of patent rights. CEN [and/or CENELEC] shall not be held responsible for identifying any or all such patent rights.

This document supersedes EN 10228-1:1999.

Annex B provides the significant technical changes to the previous version EN 10228-1:1999.

EN 10228 consists of the following parts under the general title *Non-destructive testing of steel forgings*:

- *Part 1: Magnetic particle inspection;*
- *Part 2: Penetrant testing;*
- *Part 3: Ultrasonic testing of ferritic or martensitic steel forgings;*
- *Part 4: Ultrasonic testing of austenitic and austenitic-ferritic stainless steel forgings.*

According to the CEN-CENELEC Internal Regulations, the national standards organizations of the following countries are bound to implement this European Standard: Austria, Belgium, Bulgaria, Croatia, Cyprus, Czech Republic, Denmark, Estonia, Finland, Former Yugoslav Republic of Macedonia, France, Germany, Greece, Hungary, Iceland, Ireland, Italy, Latvia, Lithuania, Luxembourg, Malta, Netherlands, Norway, Poland, Portugal, Romania, Slovakia, Slovenia, Spain, Sweden, Switzerland, Turkey and the United Kingdom.

1 Scope

This European Standard describes techniques and acceptance criteria to be used for the magnetic particle testing of forgings manufactured from ferromagnetic materials. The method described is used for the detection of surface discontinuities. It can also detect discontinuities just below the surface but the sensitivity to such discontinuities decreases rapidly with depth.

NOTE A steel forging is considered to be ferromagnetic if the magnetic flux density is greater than 1 T for a tangential magnetic field strength of 2,4 kA/m.

2 Normative references

The following documents, in whole or in part, are normatively referenced in this document and are indispensable for its application. For dated references, only the edition cited applies. For undated references, the latest edition of the referenced document (including any amendments) applies.

EN ISO 3059, *Non-destructive testing — Penetrant testing and magnetic particle testing — Viewing conditions (ISO 3059)*

EN ISO 9712, *Non-destructive testing — Qualification and certification of NDT personnel (ISO 9712)*

EN ISO 9934-1, *Non-destructive testing — Magnetic particle testing — Part 1: General principles (ISO 9934-1)*

EN ISO 9934-2, *Non-destructive testing — Magnetic particle testing — Part 2: Detection media (ISO 9934-2)*

EN ISO 9934-3, *Non-destructive testing — Magnetic particle testing — Part 3: Equipment (ISO 9934-3)*

3 Items for agreement

The following aspects concerning magnetic particle inspection shall be agreed between the purchaser and the supplier at the time of enquiry and order:

- a) the manufacturing stages(s) at which magnetic particle inspection shall be performed (see Clause 7);
- b) the surface areas to be examined (see Clause 8);
- c) the quality class required, or the quality classes and the surface areas to which they apply (see 8.2 and Clause 14);
- d) whether the testing shall be performed with the specified detection media (see 6.2);
- e) whether a particular current waveform is required (see 10.2);
- f) the applicable recording and acceptance criteria if different from those detailed in Table 2.
- g) whether demagnetization shall be carried out after testing, together with the maximum level of residual magnetism (see Clause 16);
- h) whether testing shall be conducted in the presence of the purchaser or his representative;

- i) whether a written procedure shall be submitted for approval by the purchaser (see Clause 4).

4 Test procedure

4.1 General

Magnetic particle testing shall be performed in accordance with a written test procedure. Where specified in the enquiry or order, the written procedure shall be submitted to the purchaser for approval prior to the test.

4.2 Description

This written procedure shall be one of the following:

- a) a product specification;
- b) a procedure written specifically for the application;
- c) this part of EN 10228 may be used if it is accompanied by testing details specific to the application.

4.3 Content

The procedure shall contain the following details as minimum requirements:

- a) description of the forgings to be tested;
- b) reference documents;
- c) qualification of testing personnel;
- d) stage of manufacture at which the test is carried out;
- e) surface areas specified in terms of the applicable quality classes;
- f) magnetizing technique(s);
- g) description of the testing equipment;
- h) calibration and checking of equipment;
- i) waveform and flux density and/or tangential field strength required for each technique used;
- j) detection media, and contrast paint if used;
- k) surface condition required;
- l) viewing conditions;
- m) method of marking or recording indications;
- n) whether demagnetization is required; if so the method to be used and required maximum level of residual magnetism;
- o) acceptance criteria;

p) testing report.

5 Personnel qualification

Personnel shall be qualified in accordance with EN ISO 9712.

6 Testing system

6.1 Magnetizing equipment

If the contact current flow (prods) magnetization method is used on a finished machined surface, then the prod contact points shall be checked after magnetization for damage, using an alternative magnetization technique, penetrant testing or visual examination.

All equipment shall be calibrated and checked in accordance with EN ISO 9934-3.

One or more of the following types of magnetizing equipment shall be used:

- a) alternating current electromagnetic yokes (see Annex A);
- b) current flow equipment with prods (see Annex A);
- c) permanent magnets;
- d) magnetic flow equipment with flexible cable or coil;
- e) central conductor;
- f) magnetic induction;
- g) equipment enabling multiple magnetizing techniques, either coincidentally or in sequence.

6.2 Detection media

Detection media shall conform to the requirements detailed in EN ISO 9934-2.

6.3 Function checks

A function check shall be carried out prior to the test to ensure the proper functioning of the testing system. The check shall be performed as detailed in EN ISO 9934-1.

NOTE The temperature of the forging can be checked to ensure that it is within the detection media manufacturer's specified temperature limits.

7 Stage of manufacture

Where practicable, final acceptance testing shall be performed on the forging in its delivery condition (see Clause 3).

8 Surface condition

8.1 General

Surfaces to be examined shall be clean and free from scale, oil, grease, machining marks, heavy paint and any other contaminant that could adversely affect the testing sensitivity or the interpretation of indications.

Cleaning and preparation of the surfaces shall not be detrimental to the material, the surface finish or the detection media.

8.2 Surface condition related to quality class

The finish of surfaces to be tested shall conform to the requirements detailed in Table 1 for the applicable quality class.

Table 1 — Surface condition

Surface roughness parameter R_a *), in μm	Quality classes ^a			
	1	2	3	4
$6,3 < R_a \leq 12,5$	X	X	-	-
$R_a \leq 6,3$	X	X	X ^b	X ^c
^a X signifies the quality class that can be achieved for the specified surface finish. ^b Quality class not applicable to the testing of surfaces with a machining allowance greater than 3 mm per face. ^c Quality class not applicable to the testing of surfaces with a machining allowance greater than 1 mm per face. *) R_a = arithmetical mean deviation of the profile.				

8.3 As-forged surface condition

It is difficult to carry out a comprehensive test on a forged surface. The surface to be tested shall be prepared by shot-blasting, sand-blasting or surface grinding so that defects can be clearly distinguished from indications resulting from surface irregularities.

For general applications, quality classes 1 and 2 shall be applicable.

9 Coverage

Where practicable, the test shall be performed in such a way that 100 % coverage of the surface to be tested is achieved.

Viewing of the area under testing shall be completed before proceeding to the next area or the next stage of magnetization.

10 Magnetization

10.1 Direction of magnetization

Magnetization shall be performed in accordance with the requirements detailed in EN ISO 9934-1.

The surface shall be tested in at least two approximately perpendicular directions to detect defects lying in any orientation.

NOTE 1 Where the probable nature and orientation of flaws in a forging can be forecast with confidence as, for example, in certain long forged parts, and where specified in the enquiry or order, magnetization can be performed in a single direction.

NOTE 2 Where magnetization is performed by locally applying the current flow method or using the magnetic flow method with a portable electromagnetic yoke, the surface under examination can be marked in a grid to ensure 100 % coverage. The recommended size of the grid and magnetizing directions are detailed in Annex A.

10.2 Current waveform

The supplier shall decide which waveform to use unless a specific current waveform (e.g. alternating current or half-wave rectified alternating current) has been agreed between the purchaser and supplier.

NOTE Reference can be made to EN ISO 9934-1 for guidance.

10.3 Flux density and field strength

The tangential flux density shall be at least 1,0 T. The adequacy of the flux density and/or field strength shall be verified on the surface under testing, in each magnetizing direction, prior to or during the test, using one or more of the methods detailed in EN ISO 9934-3.

A flux density of 1,0 T is generally achieved with a tangential field strength from 2kA/m to 6kA/m, dependent upon the magnetic permeability of the material being tested.

11 Use of detection media

The continuous method of application shall be used. The ink or powder shall be applied immediately prior to and during magnetization. Magnetization shall be continued for at least two seconds after the application has ceased to allow indications to build up and for the ink, if applicable, to drain.

The ink shall be thoroughly mixed prior to application.

NOTE 1 Large forgings can be tested in sections to ensure adequate ink application.

NOTE 2 Pre-wetting of the forging accelerates distribution of the ink.

12 Viewing conditions

Viewing conditions shall be in accordance with EN ISO 3059:

a) Non-fluorescent detection media:

The surface under examination shall be viewed under white light of at least 500 lx intensity on the surface. Glare and reflections shall be avoided.

NOTE Lower illuminances can be agreed between the purchaser and supplier.

b) Fluorescent detection media:

Prior to the examination at least 5 min shall be allowed for the Inspector's eyes to become adapted to the reduced background lighting.

UV-A lamps shall be allowed to warm up for at least 5 min.

13 Classification of indications

The following rules shall apply (see Figure 1):

- a) An indication shall be considered 'isolated' when it is not aligned with any other indication, or when it is aligned with another indication but separated from it by more than five times the length of the longer of the two indications considered.
- b) Interacting indications are two (or more) indications which are aligned, and shall be considered as one continuous length for the purpose of assessment if their separation is less than five times the length of the longer of the two indications considered. The length of interacting indications is the length measured between the opposite ends of the two outer indications.
- c) The cumulative length is the sum of the lengths of all indications detected in the reference surface (i.e. 148 mm × 105 mm, or = A6 format).

NOTE 1 Discontinuity indications in forgings are normally linear. This European Standard, therefore, considers only linear indications, i.e. those the length of which are at least three times the width.

- d) The Inspector shall carry out any necessary testing and observations to eliminate false indications.

NOTE 2 False indications may occur during test due to spurious effects such as magnetic writing, changes in section or boundaries between materials of different magnetic properties.

Dimensions in millimetres

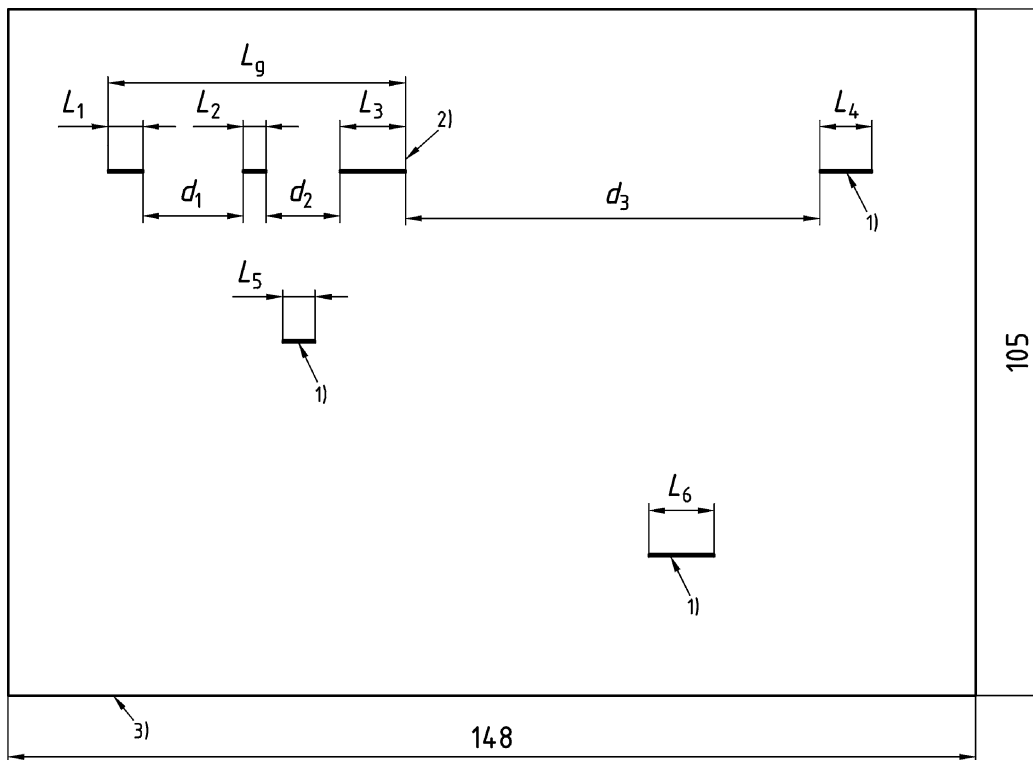

Key

- 1) isolated indications
- 2) interacting indications
- 3) reference surface where:
 - Reference surface = 148 mm × 105 mm (i.e. A6 format).
 - $d_1 = 15,2$ mm, $d_2 = 11,6$ mm, $d_3 = 63,5$ mm, $L_1 = 5,8$ mm, $L_2 = 3,6$ mm, $L_3 = 10,1$ mm, $L_4 = 7,9$ mm, $L_5 = 5,1$ mm, $L_6 = 10,1$ mm
 - $d_1 < 5L_1$; $d_2 < 5L_3$; $d_3 > 5L_3$.
 - L_1 , L_2 and L_3 = individual lengths of interacting indications.
 - L_g = total length of interacting indications
 - $L_g = (L_1 + d_1) + (L_2 + d_2) + L_3$.
 - L_4 , L_5 and L_6 = lengths of isolated indications.
 - $L_g + L_4 + L_5 + L_6$ = cumulative length of indications in reference surface.

The total number of indications in the reference surface is 4 (as identified by L_g , L_4 , L_5 and L_6), see Table 2.

Figure 1 — Classification of linear indications

14 Recording and acceptance criteria

Four quality classes shall be applied to a forging or to parts of a forging. Quality class 4 is the most stringent, dictating the smallest recording level and the smallest acceptance standard. For forgings for general application supplied in the as-forged surface condition only, quality classes 1 and 2 are applicable.

The applicable quality class(-es) shall be agreed between the purchaser and supplier prior to the test. Table 2 details recording levels and acceptance criteria that shall be applied for four quality classes.

NOTE Where agreed, recording levels and acceptance criteria different from those detailed in Table 2 can be used.

Table 2 — Quality classes, recording levels and acceptance criteria^c

Parameter	Quality class			
	1	2	3 ^a	4 ^b
Recording level: indication length (mm)	≥ 5	≥ 2	≥ 2	≥ 1
allowable length L of isolated indications and allowable length L_g of interacting indications (mm)	≤ 20	≤ 8	≤ 4	≤ 2
allowable cumulative length of indications in the reference surface (mm)	≤ 75	≤ 36	≤ 24	≤ 5
Maximum allowable number of indications in the reference surface	15	10	7	5
^a Quality class not applicable to the examination of areas with a machining allowance greater than 3 mm per face. ^b Quality class not applicable to the examination of areas with a machining allowance greater than 1 mm per face. ^c Reference surface = 148 mm × 105 mm (i.e. A6 format) For objects smaller than the reference surface, or if only an area is examined smaller than the reference surface, then the maximum allowable number of indications should be determined and agreed accordingly (the acceptance criteria for the dimensions remain unchanged).				

15 Removal of defects

Indications which do not meet the applicable acceptance criteria shall be considered as defects. Removal of a defect shall be followed by further magnetic particle inspection. Provided that the forging dimensions remain in tolerance, defects shall be eliminated by grinding and/or machining. Elimination of a defect by grinding shall be carried out in the direction perpendicular to the defect and in such a manner as to blend the resulting hollow with the remaining surface.

16 Demagnetization

Where agreed between the purchaser and the supplier, demagnetization shall be carried out after the test by use of decreasing current or magnetic flux in accordance with the requirements detailed in EN ISO 9934-1. Unless otherwise agreed, the relevant level of residual field strength shall not exceed 800 A/m.

17 Test report

All magnetic particle tests shall be the subject of a written report which shall include the following information as minimum requirements:

- a) name of supplier;
- b) order number;
- c) identification of forging(s) under examination;

- d) scope of the test: surface areas and applicable quality classes;
- e) stage of manufacture at which magnetic particle test was performed;
- f) surface condition;
- g) equipment used;
- h) magnetizing technique(s) used;
- i) waveform and flux density and/or tangential field strength for each technique used;
- j) detection media and contrast paint used including the batch number;
- k) viewing conditions;
- l) reference to this part of EN 10228 or to the written procedure used (where applicable);
- m) test results:
 - 1) location;
 - 2) classification;
 - 3) orientation and size of all indications exceeding the appropriate recording level;
 - 4) number of recorded indications in reference surface;
 - 5) description of unacceptable indications;
- n) level of residual magnetism where required;
- o) details of any restrictions to the required coverage;
- p) date of the test;
- q) name, qualification, certification (if specified) and signature of the operator.

Annex A (normative)

Magnetization using prods or electromagnetic yoke

A.1 Definition of tested area with prods or yoke

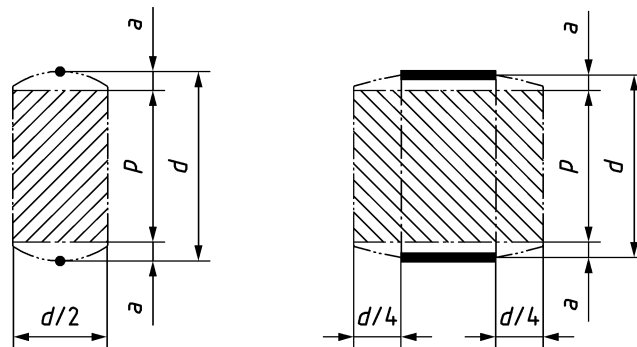

Key

- prods
- ▬ poles
- d prod spacing or pole spacing
- p, p_1, p_2 grid dimensions
- $p_1 = d - 2a; p_2 = 0,7(d - 2a)$
- $75 < d < 250$ mm
- $a = 25$ mm
- 1 and 2 magnetization direction

Figure A.1

A.2 Definition of search pattern and examination sequence

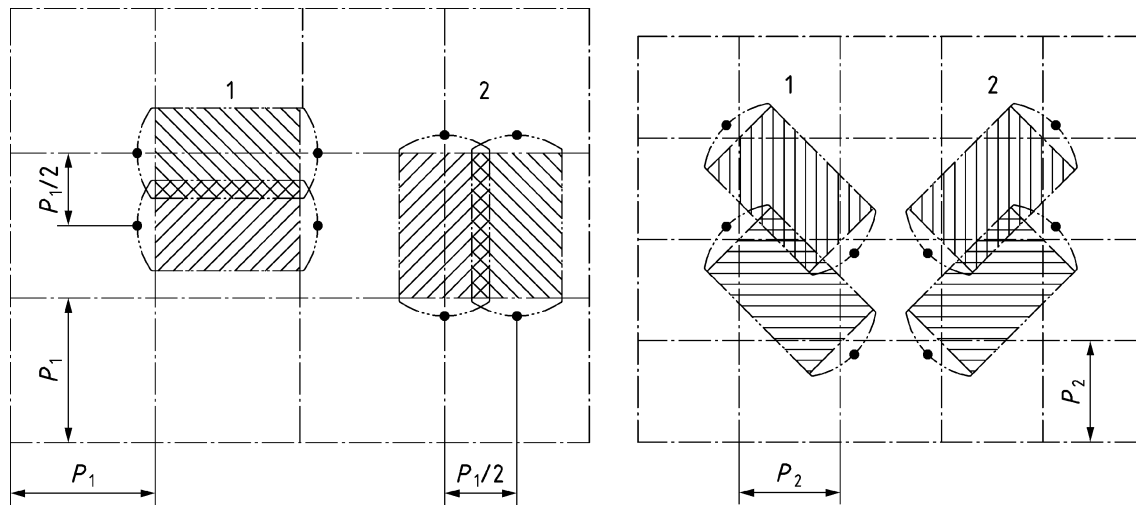

Key

- prods
- d prod spacing or pole spacing
- p, p_1, p_2 grid dimensions
- $p_1 = d - 2a; p_2 = 0,7(d - 2a)$
- $75 < d < 250$ mm
- $a = 25$ mm
- 1 and 2 magnetization direction

Figure A.2

Annex B
(informative)

Significant technical changes to the version EN 10228-1:1999

Some significant changes to the previous version EN 10228-1:1999 are listed below:

- a) actualizing updating of the normative references;
- b) updating and alignment of the designations to the actual state of art;
- c) Figure 1 and the correspondent explanations actualized;
- d) Figures A.1 and A.2 concerning magnetization using prods or electromagnetic yoke updated.

British Standards Institution (BSI)

BSI is the national body responsible for preparing British Standards and other standards-related publications, information and services.

BSI is incorporated by Royal Charter. British Standards and other standardization products are published by BSI Standards Limited.

About us

We bring together business, industry, government, consumers, innovators and others to shape their combined experience and expertise into standards-based solutions.

The knowledge embodied in our standards has been carefully assembled in a dependable format and refined through our open consultation process. Organizations of all sizes and across all sectors choose standards to help them achieve their goals.

Information on standards

We can provide you with the knowledge that your organization needs to succeed. Find out more about British Standards by visiting our website at bsigroup.com/standards or contacting our Customer Services team or Knowledge Centre.

Buying standards

You can buy and download PDF versions of BSI publications, including British and adopted European and international standards, through our website at bsigroup.com/shop, where hard copies can also be purchased.

If you need international and foreign standards from other Standards Development Organizations, hard copies can be ordered from our Customer Services team.

Copyright in BSI publications

All the content in BSI publications, including British Standards, is the property of and copyrighted by BSI or some person or entity that owns copyright in the information used (such as the international standardization bodies) and has formally licensed such information to BSI for commercial publication and use.

Save for the provisions below, you may not transfer, share or disseminate any portion of the standard to any other person. You may not adapt, distribute, commercially exploit, or publicly display the standard or any portion thereof in any manner whatsoever without BSI's prior written consent.

Storing and using standards

Standards purchased in soft copy format:

- A British Standard purchased in soft copy format is licensed to a sole named user for personal or internal company use only.
- The standard may be stored on more than 1 device provided that it is accessible by the sole named user only and that only 1 copy is accessed at any one time.
- A single paper copy may be printed for personal or internal company use only.

Standards purchased in hard copy format:

- A British Standard purchased in hard copy format is for personal or internal company use only.
- It may not be further reproduced – in any format – to create an additional copy. This includes scanning of the document.

If you need more than 1 copy of the document, or if you wish to share the document on an internal network, you can save money by choosing a subscription product (see 'Subscriptions').

Reproducing extracts

For permission to reproduce content from BSI publications contact the BSI Copyright & Licensing team.

Subscriptions

Our range of subscription services are designed to make using standards easier for you. For further information on our subscription products go to bsigroup.com/subscriptions.

With **British Standards Online (BSOL)** you'll have instant access to over 55,000 British and adopted European and international standards from your desktop. It's available 24/7 and is refreshed daily so you'll always be up to date.

You can keep in touch with standards developments and receive substantial discounts on the purchase price of standards, both in single copy and subscription format, by becoming a **BSI Subscribing Member**.

PLUS is an updating service exclusive to BSI Subscribing Members. You will automatically receive the latest hard copy of your standards when they're revised or replaced.

To find out more about becoming a BSI Subscribing Member and the benefits of membership, please visit bsigroup.com/shop.

With a **Multi-User Network Licence (MUNL)** you are able to host standards publications on your intranet. Licences can cover as few or as many users as you wish. With updates supplied as soon as they're available, you can be sure your documentation is current. For further information, email subscriptions@bsigroup.com.

Revisions

Our British Standards and other publications are updated by amendment or revision.

We continually improve the quality of our products and services to benefit your business. If you find an inaccuracy or ambiguity within a British Standard or other BSI publication please inform the Knowledge Centre.

Useful Contacts

Customer Services

Tel: +44 345 086 9001

Email (orders): orders@bsigroup.com

Email (enquiries): cservices@bsigroup.com

Subscriptions

Tel: +44 345 086 9001

Email: subscriptions@bsigroup.com

Knowledge Centre

Tel: +44 20 8996 7004

Email: knowledgecentre@bsigroup.com

Copyright & Licensing

Tel: +44 20 8996 7070

Email: copyright@bsigroup.com

BSI Group Headquarters

389 Chiswick High Road London W4 4AL UK