



BSI Standards Publication

Seamless steel tubes for pressure purposes — Technical delivery conditions

Part 4: Non-alloy and alloy steel tubes with
specified low temperature properties

National foreword

This British Standard is the UK implementation of EN 10216-4:2013. It supersedes BS EN 10216-4:2002 which is withdrawn.

The UK participation in its preparation was entrusted to Technical Committee ISE/110, Steel Tubes, and Iron and Steel Fittings.

A list of organizations represented on this committee can be obtained on request to its secretary.

This publication does not purport to include all the necessary provisions of a contract. Users are responsible for its correct application.

© The British Standards Institution 2013. Published by BSI Standards Limited 2013

ISBN 978 0 580 68643 6

ICS 23.040.10; 77.140.75

Compliance with a British Standard cannot confer immunity from legal obligations.

This British Standard was published under the authority of the Standards Policy and Strategy Committee on 31 December 2013.

Amendments issued since publication

Date	Text affected
------	---------------

EUROPEAN STANDARD

EN 10216-4

NORME EUROPÉENNE

EUROPÄISCHE NORM

December 2013

ICS 23.040.10; 77.140.75

Supersedes EN 10216-4:2002

English Version

Seamless steel tubes for pressure purposes - Technical delivery conditions - Part 4: Non-alloy and alloy steel tubes with specified low temperature properties

Tubes sans soudure en acier pour service sous pression -
Conditions techniques de livraison - Partie 4 : Tubes en
acier non allié et allié avec caractéristiques spécifiées à
basse température

Nahtlose Stahlrohre für Druckbeanspruchungen -
Technische Lieferbedingungen - Teil 4: Rohre aus
unlegierten und legierten Stählen mit festgelegten
Eigenschaften bei tiefen Temperaturen

This European Standard was approved by CEN on 17 August 2013.

CEN members are bound to comply with the CEN/CENELEC Internal Regulations which stipulate the conditions for giving this European Standard the status of a national standard without any alteration. Up-to-date lists and bibliographical references concerning such national standards may be obtained on application to the CEN-CENELEC Management Centre or to any CEN member.

This European Standard exists in three official versions (English, French, German). A version in any other language made by translation under the responsibility of a CEN member into its own language and notified to the CEN-CENELEC Management Centre has the same status as the official versions.

CEN members are the national standards bodies of Austria, Belgium, Bulgaria, Croatia, Cyprus, Czech Republic, Denmark, Estonia, Finland, Former Yugoslav Republic of Macedonia, France, Germany, Greece, Hungary, Iceland, Ireland, Italy, Latvia, Lithuania, Luxembourg, Malta, Netherlands, Norway, Poland, Portugal, Romania, Slovakia, Slovenia, Spain, Sweden, Switzerland, Turkey and United Kingdom.



EUROPEAN COMMITTEE FOR STANDARDIZATION
COMITÉ EUROPÉEN DE NORMALISATION
EUROPÄISCHES KOMITEE FÜR NORMUNG

CEN-CENELEC Management Centre: Avenue Marnix 17, B-1000 Brussels

Contents	Page
Foreword	4
1 Scope	5
2 Normative references	5
3 Terms and definitions	6
4 Symbols	6
5 Classification and designation	6
5.1 Classification	6
5.2 Designation	7
6 Information to be supplied by the purchaser	7
6.1 Mandatory information	7
6.2 Options	7
6.3 Example of an order	8
7 Manufacturing process	8
7.1 Steelmaking process	8
7.2 Tube manufacture and delivery conditions	8
8 Requirements	9
8.1 General	9
8.2 Chemical composition	10
8.3 Mechanical properties	12
8.4 Appearance and internal soundness	14
8.5 Straightness	14
8.6 Preparation of ends	14
8.7 Dimensions, masses and tolerances	15
9 Inspection	19
9.1 Types of inspection	19
9.2 Inspection documents	19
9.3 Summary of inspection and verification testing	20
10 Sampling	20
10.1 Frequency of tests	20
10.2 Preparation of samples and test pieces	21
11 Verification test methods	22
11.1 Chemical analysis	22
11.2 Tensile test	22
11.3 Flattening test	22
11.4 Ring tensile test	23
11.5 Drift expanding test	23
11.6 Ring expanding test	24
11.7 Impact test	24
11.8 Leak tightness test	24
11.9 Dimensional inspection	25
11.10 Visual examination	25
11.11 Non-Destructive Testing	25
11.12 Material identification	26
11.13 Retests, sorting and reprocessing	26
12 Marking	26
12.1 Marking to be applied	26
12.2 Additional marking	26
13 Protection	27
Annex A (informative) Technical changes from the previous edition	28

Annex ZA (informative) Relationship between this European Standard and the Essential Requirements of EU Directive 97/23/EC29

Bibliography30

Foreword

This document (EN 10216-4:2013) has been prepared by Technical Committee ECISS/TC 110 "Steel tubes and fittings for steel tubes", the secretariat of which is held by UNI.

This European Standard shall be given the status of a national standard, either by publication of an identical text or by endorsement, at the latest by June 2014, and conflicting national standards shall be withdrawn at the latest by June 2014.

Attention is drawn to the possibility that some of the elements of this document may be the subject of patent rights. CEN [and/or CENELEC] shall not be held responsible for identifying any or all such patent rights.

This document supersedes EN 10216-4:2002.

For the list of the most significant technical changes that have been made in this new edition, see Annex A.

This document has been prepared under a mandate given to CEN by the European Commission and the European Free Trade Association, and supports essential requirements of EU Directive(s).

For relationship with EU Directive(s), see informative Annex ZA, which is an integral part of this document.

This European Standard consists of the following parts, under the general title "*Seamless steel tubes for pressure purposes – Technical delivery conditions*":

Part 1 :Non-alloy steel tubes with specified room temperature properties;

Part 2 :Non-alloy and alloy steel tubes with specified elevated temperature properties;

Part 3 :Alloy fine grain steel tubes;

Part 4: Non-alloy and alloy steel tubes with specified low temperature properties (the present document);

Part 5 :Stainless steel tubes.

Another European Standard series covering tubes for pressure purposes is:

EN 10217: Welded steel tubes for pressure purposes —Technical delivery conditions.

According to the CEN-CENELEC Internal Regulations, the national standards organizations of the following countries are bound to implement this European Standard: Austria, Belgium, Bulgaria, Croatia, Cyprus, Czech Republic, Denmark, Estonia, Finland, Former Yugoslav Republic of Macedonia, France, Germany, Greece, Hungary, Iceland, Ireland, Italy, Latvia, Lithuania, Luxembourg, Malta, Netherlands, Norway, Poland, Portugal, Romania, Slovakia, Slovenia, Spain, Sweden, Switzerland, Turkey and the United Kingdom.

1 Scope

This European Standard specifies the technical delivery conditions in two test categories for seamless tubes of circular cross section, with specified low temperature properties, made of non-alloy and alloy steel.

NOTE Once this standard is published in the Official Journal of the European Union (OJEU) under Directive 97/23/EC, presumption of conformity to the Essential Safety Requirements (ESR) of Directive 97/23/EC is limited to technical data of materials in this standard and does not presume adequacy of the material to a specific item of equipment. Consequently, the assessment of the technical data stated in this material standard against the design requirements of this specific item of equipment to verify that the ESRs of the Pressure Equipment Directive are satisfied, needs to be done by the designer or manufacturer of the pressure equipment, taking also into account the subsequent manufacturing processes which may affect properties of the base materials.

2 Normative references

The following documents, in whole or in part, are normatively referenced in this document and are indispensable for its application. For dated references, only the edition cited applies. For undated references, the latest edition of the referenced document (including any amendments) applies.

EN 10020, *Definition and classification of grades of steel*

EN 10021, *General technical delivery conditions for steel products*

EN 10027-1, *Designation systems for steels - Part 1: Steel names*

EN 10027-2, *Designation systems for steels - Part 2: Numerical system*

EN 10052, *Vocabulary of heat treatment terms for ferrous product*

EN 10168:2004, *Steel products - Inspection documents - List of information and description*

EN 10204:2004, *Metallic products - Types of inspection documents*

EN 10220, *Seamless and welded steel tubes - Dimensions and masses per unit length*

EN 10266, *Steel tubes, fittings and structural hollow sections - Symbols and definitions of terms for use in product standards*

CEN/TR 10261, *Iron and steel - Review of available methods of chemical analysis*

EN ISO 148-1:2010, *Metallic materials - Charpy pendulum impact test - Part 1: Test method (ISO 148-1:2009)*

EN ISO 377:2013, *Steel and steel products - Location and preparation of samples and test pieces for mechanical testing (ISO 377:2013)*

EN ISO 2566-1, *Steel - Conversion of elongation values – Part 1: Carbon and low-alloy steels (ISO 2566-1)*

EN ISO 6892-1:2009, *Metallic materials - Tensile testing - Part 1: Method of test at room temperature (ISO 6892-1:2009)*

EN ISO 8492:2004, *Metallic materials - Tube - Flattening test (ISO 8492:1998)*

EN ISO 8493:2004, *Metallic materials - Tube - Drift expanding test (ISO 8493:1998)*

EN ISO 8495:2004, *Metallic materials - Tube - Ring expanding test (ISO 8495:1998)*

EN ISO 8496:2004, *Metallic materials - Tube - Ring tensile test (ISO 8496:1998)*

EN ISO 10893-1, *Non-destructive testing of steel tubes - Part 1: Automated electromagnetic testing of seamless and welded (except submerged arc-welded) steel tubes for the verification of hydraulic leak-tightness (ISO 10893-1)*

EN ISO 10893-3, *Non-destructive testing of steel tubes - Part 3: Automated full peripheral flux leakage testing of seamless and welded (except submerged arc-welded) ferromagnetic steel tubes for the detection of longitudinal and/or transverse imperfections (ISO 10893-3)*

EN ISO 10893-8, *Non-destructive testing of steel tubes - Part 8: Automated ultrasonic testing of seamless and welded steel tubes for the detection of laminar imperfections (ISO 10893-8)*

EN ISO 10893-10, *Non-destructive testing of steel tubes - Part 10: Automated full peripheral ultrasonic testing of seamless and welded (except submerged arc-welded) steel tubes for the detection of longitudinal and/or transverse imperfections (ISO 10893-10)*

EN ISO 14284:2002, *Steel and iron - Sampling and preparation of samples for the determination of chemical composition (ISO 14284)*

ISO 11484:2009, *Steel products - Employer's qualification system for non-destructive testing (NDT) personnel*

3 Terms and definitions

For the purposes of this document, the terms and definitions given in EN 10020, EN 10021, EN 10052, EN 10266 and the following apply.

3.1

test category

classification that indicates the extent and level of inspection and testing

3.2

employer

organization for which a person works on a regular basis

Note 1 to entry: The employer may be either the tube manufacturer or supplier or a third party organization providing Non-Destructive Testing (NDT) services.

4 Symbols

For the purposes of this document, the symbols given EN 10266 and the following apply.

— TC test category

5 Classification and designation

5.1 Classification

In accordance with the classification system in EN 10020, the steel grades P 215NL, P 255QL and P265NL are classified as non-alloy quality steels and the other steel grades are classified as alloy special steels.

5.2 Designation

5.2.1 For the tubes covered by this document, the steel designation consists of:

— the number of this Part of EN 10216;

plus either

— the steel name in accordance with EN 10027-1;

or

— the steel number allocated in accordance with EN 10027-2.

5.2.2 The steel name of non-alloy steel grades is designated by:

— the capital letter P for pressure purposes;

— the indication of the specified minimum yield strength at room temperature, expressed in MPa (see Table 4);

— the symbol of the heat treatment for the steel grade concerned (see Table 1);

— the symbol L for low temperature.

5.2.3 The steel name of alloy-steel grades is designated by the chemical composition (see Table 2) and the symbols for the heat treatment, where specified in column 1 and footnote a) of Table 1.

6 Information to be supplied by the purchaser

6.1 Mandatory information

The following information shall be supplied by the purchaser at the time of enquiry and order:

- a) the quantity (mass or total length or number);
- b) the term "tube";
- c) the dimensions (outside diameter D and wall thickness T) (see Table 6);
- d) the designation of the steel grade in accordance with this Part of EN 10216 (see 5.2);
- e) the test category for non-alloy steel (see 9.3).

6.2 Options

A number of options are specified in this Part of EN 10216 and these are listed below. In the event that the purchaser does not indicate a wish to implement any of these options at the time of enquiry and order, the tubes shall be supplied in accordance with the basic specification (see 6.1).

- 1) Cold finishing (see 7.2.2);
- 2) restriction on copper and tin content (see Table 2);
- 3) product analysis (see 8.2.2);
- 4) selection of test method for verification of leak-tightness (see 8.4.2.1);

- 5) Non-Destructive Testing for test category 2 tubes for detection of transverse imperfections (see 8.4.2.2);
- 6) Non-Destructive Testing for test category 2 tubes for detection of laminar imperfections (see 8.4.2.2);
- 7) special ends preparation (see 8.6);
- 8) exact lengths (see 8.7.3);
- 9) inspection certificate 3.2 other than the standard document (see 9.2.1);
- 10) test pressure for hydrostatic leak-tightness test (see 11.8.1);
- 11) wall thickness measurement away from the ends (see 11.9);
- 12) Non-Destructive Testing method (see 11.11.1);
- 13) additional marking (see 12.2);
- 14) protection (see 13).

6.3 Example of an order

50 t of seamless tube with an outside diameter of 168,3 mm, a wall thickness of 4,5 mm in accordance with EN 10216-4, made of steel grade P265NL, test category 1, with a 3.2 inspection certificate in accordance with EN 10204:

EXAMPLE 50 t - Tube - 168,3 x 4,5 - EN 10216-4 - P265NL - TC1 - Option 9: 3.2.

7 Manufacturing process

7.1 Steelmaking process

The steelmaking process is at the discretion of the manufacturer with the exception that the open hearth (Siemens-Martin) process shall not be employed unless in combination with a secondary steelmaking or ladle refining process.

Steels shall be fully killed.

NOTE This excludes the use of rimming, balanced or semi-killed steel.

7.2 Tube manufacture and delivery conditions

7.2.1 All NDT activities shall be carried out by qualified and competent level 1, 2 and/or 3 personnel authorized to operate by the employer.

The qualification shall be in accordance with ISO 11484 or, at least, an equivalent to it.

It is recommended that the level 3 personnel be certified in accordance with EN ISO 9712 or, at least, an equivalent to it.

The operating authorization issued by the employer shall be in accordance with a written procedure.

NDT operations shall be authorized by level 3 NDT individual approved by the employer.

NOTE The definition of level 1, 2 and 3 can be found in appropriate standards, e.g. EN ISO 9712 and ISO 11484.

7.2.2 The tubes shall be manufactured by a seamless process.

Unless option 1 is specified, the tubes may be either hot or cold finished at the discretion of the manufacturer. The terms “ hot finished “ and “ cold finished “ apply to the condition of the tube before it is heat treated in accordance with 7.2.3.

Option 1: The tubes shall be cold finished before heat treatment.

7.2.3 The tubes shall be supplied in the relevant heat treatment conditions as specified in Table 1.

Table 1 — Delivery conditions

Steel grade		Heat treatment ^{a b}	Normalizing temperature °C	Tempering temperature °C	Quenching and tempering		
Steel name	Steel number				Hardening temperature °C	Cooling medium ^c	Tempering temperature °C
P215NL	1.0451	+N	900 to 940	--	--	--	--
P255QL	1.0452	+QT	--	--	890 to 930	Water or oil	600 to 680
P265NL	1.0453	+N	880 to 940	--	--	--	--
26CrMo4-2	1.7219	+QT	--	--	830 to 860	Water or oil	600 to 680
11 MnNi5-3	1.6212	+N ^d	890 to 940	(580 to 640)	--	--	--
13 MnNi6-3	1.6217	+N ^d	890 to 940	(580 to 640)	--	--	--
12Ni14	1.5637	+NT	830 to 880	580 to 640	--	--	--
		+QT	--	--	820 to 880	Water or oil	580 to 660
X12Ni5	1.5680	+NT	800 to 850	580 to 640	--	--	--
		+QT	--	--	800 to 850	Water or oil	580 to 660
X10Ni9	1.5682	+N+NT	880 to 915 + 775 to 805	565 to 605 ^e	-	--	--
		+QT ^f	(880 to 930)	--	770 to 820	water or oil	540 to 600

^a N = Normalizing ; QT = Quenching and Tempering; NT = Normalizing and Tempering.
^b Where two types of heat treatment are specified for a steel grade, the application depends on wall thickness and T/D ratio. The decision is left to the manufacturer but shall be reported in the inspection document.
^c When choosing the cooling medium, the influence of other parameters, such as dimensions and quenching temperature, on properties and crack susceptibility should be taken into account. Other cooling media such as synthetic quenchants may also be used.
^d Tempering can occasionally be necessary after normalizing; the decision shall be left to the discretion of the manufacturer but shall be stated to the customer at the time of enquiry and order. Steel tubes treated in such a way shall be designated by the steel name supplemented by the symbol “+NT “.
^e Cooling at still air or accelerated cooling.
^f An additional prenormalizing treatment, in the temperature range indicated may be necessary for this grade. In such a case, the manufacturer shall inform the purchaser.

8 Requirements

8.1 General

When supplied in a delivery condition indicated in 7.2 and inspected in accordance with Clauses 9, 10 and 11, the tubes shall conform to the requirements of this Part EN 10216.

In addition, the general technical delivery requirements specified in EN 10021 shall apply.

Tubes shall be suitable for hot and cold bending provided the bending is carried out in an appropriate manner.

8.2 Chemical composition

8.2.1 Cast analysis

The cast analysis reported by the steel producer shall apply and conform to with the requirements of Table 2.

When welding tubes are produced in accordance with this Part of EN 10216, account should be taken of the fact that the behaviour of the steel during and after welding is dependent not only on the steel, but also on the applied heat treatment and the conditions of preparing for and carrying out the welding.

8.2.2 Product analysis

Option 3: *A product analysis for the tubes shall be supplied.*

Table 3 specifies the permissible deviations of the product analysis from the specified limits on cast analysis given in Table 2.

Table 2 — Chemical composition (cast analysis) ^a, in % by mass

Steel grade		C	Si	Mn	P max	S max	Cr	Ni	Mo	Al ^{total} ^b	Cu ^c	Nb max	Ti max	V max
Steel name	Steel number									min	max			
P215NL	1.0451	≤ 0,15	≤ 0,35	0,40 to 1,20	0,025	0,010	≤ 0,30	≤ 0,30	≤ 0,08	0,020	0,30	0,010	0,040	0,02
P255QL	1.0452	≤ 0,17	≤ 0,35	0,40 to 1,20	0,025	0,010	≤ 0,30	≤ 0,30	≤ 0,08	0,020	0,30	0,010	0,040	0,02
P265NL	1.0453	≤ 0,20	≤ 0,40	0,60 to 1,40	0,025	0,010	≤ 0,30	≤ 0,30	≤ 0,08	0,020	0,30	0,010	0,040	0,02
26CrMo4-2	1.7219	0,22 to 0,29	≤ 0,35	0,50 to 0,80	0,025	0,010	0,90 to 1,20	--	0,15 to 0,30	--	0,30	--	--	--
11MnNi5-3	1.6212	≤ 0,14	≤ 0,50	0,70 to 1,50	0,025	0,010	--	0,30 ^d to 0,80	--	0,020	0,30	0,05	--	0,05
13MnNi6-3	1.6217	≤ 0,16	≤ 0,50	0,85 to 1,70	0,025	0,010	--	0,30 ^d to 0,85	--	0,020	0,30	0,05	--	0,05
12Ni14	1.5637	≤ 0,15	0,15 to 0,35	0,30 to 0,80	0,025	0,005	--	3,25 to 3,75	--	--	0,30	--	--	0,05
X12Ni5	1.5680	≤ 0,15	≤ 0,35	0,30 to 0,80	0,020	0,005	--	4,5 to 5,3	--	--	0,30	--	--	0,05
X10Ni9	1.5682	≤ 0,13	0,15 to 0,35	0,30 to 0,80	0,020	0,005	--	8,5 to 9,5	≤ 0,10	--	0,30	--	--	0,05

^a Elements not included in this table shall not be intentionally added to the steel without the agreement of the purchaser, except for elements which may be added for finishing the cast. All appropriate measures shall be taken to prevent the addition of undesirable elements from scrap or other materials used in the steel making process.

^b By agreement between purchaser and manufacturer, aluminium may be replaced by other elements having a similar effect.

^c **Option 2:** In order to facilitate subsequent forming operation, an agreed maximum copper content lower than indicated and an agreed specified maximum tin content shall apply.

^d The lower limit for the nickel content may be reduced to not less than 0,15 % for tubes with wall thickness not exceeding 10 mm.

Table 3 — Permissible deviations of the product analysis from specified limits on cast analysis given in Table 2

Element	Limiting value for the cast analysis in accordance with Table 2 % by mass	Permissible deviation of the product analysis % by mass
C	≤ 0,29	± 0,02
Si	≤ 0,40	± 0,05
	> 0,40 to ≤ 0,50	+ 0,06
Mn	≤ 1,70	+ 0,10 - 0,05
P	≤ 0,025	+ 0,005
S	≤ 0,015	+ 0,003
	> 0,015 to ≤ 0,020	+ 0,005
Al	≥ 0,020	- 0,005
Cr	≤ 1,20	± 0,10
Cu	≤ 0,30	+ 0,05
Mo	≤ 0,30	± 0,05
Nb	≤ 0,05	+ 0,005
Ni	≤ 0,85	± 0,05
	> 0,85 to ≤ 3,75	± 0,07
	> 3,75 to ≤ 5,3	± 0,10
	> 5,3 to ≤ 9,5	± 0,15
Ti	≤ 0,040	+ 0,01
V	≤ 0,05	+ 0,01

8.3 Mechanical properties

The mechanical properties of the tubes shall conform to the requirements in Table 4 and Table 5 and in 11.3 to 11.7, irrespective of whether they are verified or not (see Table 10).

Table 4 — Mechanical properties at room temperature for wall thickness up to and including 40 mm

Steel grade		Tensile properties			
Steel Name	Steel number	Upper yield strength or proof strength R_{eH} or $R_{p0,2}$ min MPa *	Tensile strength R_m MPa *	Elongation A_{min} % ^a	
				l	t
P215NL	1.0451	215 ^b	360 to 480	25	23
P255QL	1.0452	255	360 to 490	23	21
P265NL	1.0453	265 ^c	410 to 570	24	22
26CrMo4-2	1.7219	440	560 to 740	18	16
11MnNi5-3	1.6212	285	410 to 530	24	22
13MnNi6-3	1.6217	355	490 to 610	22	20
12Ni14	1.5637	345	440 to 620	22	20
X12Ni5	1.5680	390	510 to 710	21	19
X10Ni9	1.5682	510	690 to 840	20	18

^a l = longitudinal t = transverse.
^b For wall thickness ≤ 10 mm.
^c For wall thickness ≤ 25 mm.
* 1 MPA = 1N/mm²

Table 5 — Minimum impact energy

Steel Grade		Wall thickness T mm	Orientation of test pieces with respect to tube axis	Minimum average impact energy KV ₂ J at a temperature of °C										
				-196	-120	-110	-100	-90	-60	-50	-40	-20	+20	
P215NL	1.0451	≤ 10	Longitudinal	-	-	-	-	-	-	-	-	40	45	55
P255QL	1.0452	≤ 25	Longitudinal	-	-	-	-	-	-	-	40	45	50	60
			Transverse	-	-	-	-	-	-	-	27	30	35	40
		> 25 to ≤ 40	Longitudinal	-	-	-	-	-	-	-	-	40	45	55
			Transverse	-	-	-	-	-	-	-	-	27	30	35
P265NL	1.0453	≤ 25	Longitudinal	-	-	-	-	-	-	-	-	40	45	50
			Transverse	-	-	-	-	-	-	-	-	27	30	35
26CrMo4-2	1.7219	≤ 40	Longitudinal	-	-	-	-	-	40	40	45	50	60	
			Transverse	-	-	-	-	-	27	27	30	35	40	
11MnNi5-3	1.6212	≤ 40	Longitudinal	-	-	-	-	-	40	45	50	55	70	
13MnNi6-3	1.6217		Transverse	-	-	-	-	-	27	30	35	40	45	
12Ni14	1.5637	≤ 25	Longitudinal	-	-	-	40	45	50	55	55	60	65	
			Transverse	-	-	-	27	30	35	35	40	45	45	
		> 25 to ≤ 40	Longitudinal	-	-	-	-	40	45	50	50	55	65	
			Transverse	-	-	-	-	27	30	30	35	40	45	
X12Ni5	1.5680	≤ 25	Longitudinal	-	40	45	50	55	65	65	65	70	70	
			Transverse	-	27	30	30	35	45	45	45	50	50	
		> 25 to ≤ 40	Longitudinal	-		40	45	50	60	65	65	65	70	
			Transverse	-		27	30	30	40	45	45	45	50	
X10Ni9	1.5682	≤ 40	Longitudinal	40	50	50	60	60	70	70	70	70	70	
			Transverse	27	35	35	40	40	50	50	50	50	50	

8.4 Appearance and internal soundness

8.4.1 Appearance

8.4.1.1 The tubes shall be free from external and internal surface defects that can be detected by visual examination.

8.4.1.2 The internal and external surface finish of the tubes shall be typical of the manufacturing process and the heat treatment employed. Normally the finish and surface condition shall be such that any surface imperfections or marks requiring dressing can be identified.

8.4.1.3 It shall be permissible to dress, only by grinding or machining, surface imperfections provided that after doing so, the wall thickness in the dressed area is not less than the specified minimum wall thickness. All dressed areas shall blend smoothly into the contour of the tube.

8.4.1.4 Any surface imperfection, which is demonstrated to be deeper than 5 % of the wall thickness T or 3 mm whichever is the smaller, shall be dressed.

This requirement does not apply to surface imperfection with a depth equal or less 0,3 mm.

8.4.1.5 Surface imperfections which encroach on the specified minimum wall thickness shall be considered defects and tubes containing these shall be deemed not to comply with this Part of EN 10216.

8.4.2 Internal soundness

8.4.2.1 Leak-tightness

The tubes shall pass a hydrostatic test (see 11.8.1) or electromagnetic test (see 11.8.2) for leak-tightness.

Unless option 4 is specified. the choice of the test method is at the discretion of the manufacturer.

Option 4: *The test method for verification of leak-tightness in accordance with 11.8.1 or 11.8.2 is specified by the purchaser.*

8.4.2.2 Non-Destructive Testing

The tubes of test category 2 shall be subjected to a Non-Destructive Testing for the detection of longitudinal imperfections, in accordance with 11.11.1.

Option 5: *The tubes of test category 2 shall be subjected to a Non-Destructive testing for the detection of transverse imperfections in accordance with 11.11.2.*

Option 6: *The tubes of test category 2 shall be subjected to a Non-Destructive testing for the detection of the laminar imperfections in accordance with 11.11.3.*

8.5 Straightness

The deviation from straightness of any tube length L shall not exceed $0,0015 L$. Deviations from straightness over any one metre length shall not exceed 3 mm.

8.6 Preparation of ends

Tubes shall be delivered with square cut ends. The ends shall be free from excessive burrs.

Option 7: The tubes shall be delivered with bevelled ends (see Figure 1). The bevel shall have an angle α of $30^{\circ} \begin{smallmatrix} +5^{\circ} \\ 0^{\circ} \end{smallmatrix}$ with a root face C of $1,6 \text{ mm} \pm 0,8 \text{ mm}$, except that for wall thickness T greater than 20 mm, an alternative bevel may be specified.

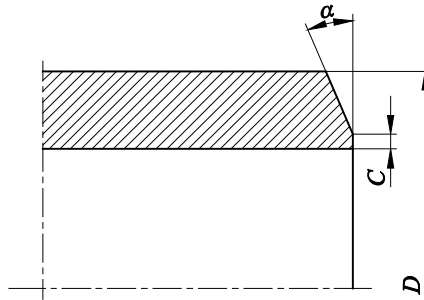

Key:

- D outside diameter
- α bevel angle
- C root face of bevelled end

Figure 1 — Tube end bevel

8.7 Dimensions, masses and tolerances

8.7.1 Diameter and wall thickness

Tubes shall be delivered by outside diameter D and wall thickness T .

Preferred outside diameters D and wall thicknesses T have been selected from EN 10220 and are given in Table 6.

Dimensions which are different from those in Table 6 may be agreed.

8.7.2 Mass

For the mass per unit length, the provisions of EN 10220 apply.

Table 6 — Preferred dimensions

Dimensions in millimetres

Outside diameter D series ^a			Wall thicknesses T mm																				
1	2	3	1,6	1,8	2	2,3	2,6	2,9	3,2	3,6	4	4,5	5	5,6	6,3	7,1	8	8,8	10	11	12,5	14,2	
10,2																							
	12																						
	12,7																						
13,5																							
	14																						
	16																						
17,2																							
	18																						
	19																						
	20																						
21,3																							
	22																						
	25																						
	25,4																						
26,9																							
	30																						
	31,8																						
	32																						
33,7																							
	35																						
	38																						
	40																						
42,4																							
	44,5																						
48,3																							
	51																						
	54																						
	57																						
60,3																							
	63,5																						
	70																						
	73																						
76,1																							
	82,5																						
88,9																							
	101,6																						
	108																						
114,3																							
	127																						
	133																						
139,7																							
	141,3																						
	152,4																						
	159																						
168,3																							
	177,8																						
	193,7																						
219,1																							
	224,5																						
273																							
323,9																							
355,6																							
406,4																							
457																							
508																							
	559																						
610																							
	660																						
711																							

Table 6 (continued)

Outside diameter <i>D</i> series ^a			Wall thicknesses <i>T</i> mm									
1	2	3	16	17,5	20	22,2	25	28	30	32	36	40
10,2												
	12											
	12,7											
13,5												
		14										
	16											
17,2												
		18										
	19											
	20											
21,3												
		22										
	25											
		25,4										
26,9												
		30										
	31,8											
	32											
33,7												
		35										
	38											
	40											
42,4												
		44,5										
48,3												
	51											
		54										
	57											
60,3												
	63,5											
	70											
		73										
76,1												
		82,5										
88,9												
	101,6											
		108										
114,3												
	127											
	133											
139,7												
		141,3										
		152,4										
		159										
168,3												
		177,8										
		193,7										
219,1												
		244,5										
273												
323,9												
355,6												
406,4												
457												
508												
		559										
610												
		660										
711												

^a series 1 = diameter for which all the accessories needed for the construction of piping system are standardized;
series 2 = diameter for which not all the accessories are standardized;
series 3 = diameter for special application for which very few standardized accessories exist.

8.7.3 Lengths

Unless option 8 is specified, the tubes shall be delivered in random length. The delivery range shall be agreed at the time of enquiry and order.

Option 8: The tubes shall be delivered in exact lengths and the length shall to be specified at the time of enquiry and order. For tolerances see 8.7.4.2.

8.7.4 Tolerances

8.7.4.1 Tolerances on diameter and thickness

The diameter and the wall thickness of the tubes shall be within the relevant tolerance limits given in Table 7 or Table 8.

Out of roundness is included in the tolerances on diameter and eccentricity is included in the tolerances on wall thickness.

Table 7 — Tolerances on outside diameter and wall thickness

Outside Diameter D mm	Tolerances on D	Tolerances on T for a T/D ratio			
		$\leq 0,025$	$> 0,025$ $\leq 0,050$	$> 0,050$ $\leq 0,10$	$> 0,10$
$D \leq 219,1$	$\pm 1\%$ or $\pm 0,5$ mm whichever is the greater	$\pm 12,5\%$ or $\pm 0,4$ mm whichever is the greater			
$D > 219,1$		$\pm 20\%$	$\pm 15\%$	$\pm 12,5\%$	$\pm 10\%$ ^a

^a For outside diameters $D \geq 355,6$ mm, it is permitted to exceed the upper wall thickness locally by a further 5 % of the wall thickness T .

Table 8 — Tolerances on outside diameter and wall thickness for tube ordered cold finished

Tolerance on D	Tolerance on T
$\pm 0,5\%$ or $\pm 0,3$ mm whichever is the greater	$\pm 10\%$ or $\pm 0,2$ mm whichever is the greater

8.7.4.2 Tolerances on exact lengths

The tolerances for exact lengths shall be as given in Table 9.

Table 9 — Tolerances on exact lengths

Dimensions in millimetres	
Length L	Tolerance on exact length
$L \leq 6\ 000$	+10 0
$6\ 000 < L \leq 12\ 000$	+15 0
$L > 12\ 000$	+ by agreement 0

9 Inspection

9.1 Types of inspection

Conformity to the requirements of the order, for tubes in accordance with this Part of EN 10216, shall be verified by specific inspection.

When an Inspection Certificate 3.1 is specified, the material manufacturer shall state in the confirmation of the order whether he is operating according to a “quality–assurance system”, certified by a competent Body established within the Community, and having undergone a specific assessment for materials.

NOTE See the EU Directive 97/23/EC, Annex I, section 4.3 third paragraph and for further information the Guidelines of the EU Commission and the Member States for its interpretation (see e.g. Guidelines 7/2 and 7/16).

9.2 Inspection documents

9.2.1 Types of inspection documents

Unless option 13 is specified, an inspection certificate 3.1, in accordance with EN 10204, shall be issued.

Option 9: *Inspection Certificate 3.2 in accordance with EN 10204 shall be issued.*

If an inspection certificate 3.2 is specified, the purchaser shall notify the manufacturer of the name and address of the organization or person who is to carry out the inspection and produce the inspection document, and it shall be agreed which party shall issue the certificate.

Document 3.1 and 3.2 are to be validated by manufacturer's authorized representative.

9.2.2 Content of inspection documents

The content of the inspection documents shall be in accordance with EN 10168.

In all type of inspection documents, a statement on the conformity of the products delivered with the requirements of this specification and the order shall be included.

The Inspection documents shall contain the following codes and information:

- A commercial transactions and parties involved;
- B description of products to which the inspection document applies;
- C02-C03 direction of the test pieces and testing temperature;
- C10-C13 tensile test;
- C40-C43 impact test, if applicable;
- C60-C69 other tests;
- C71-C92 chemical composition on cast analysis (product analysis, if applicable);
- D01 marking and identification, surface appearance, shape and dimensional properties;
- D02-D99 leak-tightness test, NDT, material identification, if applicable;
- Z validation.

In addition to the inspection certificate 3.1, the manufacturer shall state the references to the certificate (see 9.1) of the appropriate “quality–assurance system”, if applicable.

9.3 Summary of inspection and verification testing

Non-alloy steel tubes shall be inspected and tested in accordance with test category 1 or test category 2 as specified at the time of inquiry and order (see 6.1).

Alloyed steel tubes shall be inspected and tested in accordance with test category 2 (see Table 10).

Inspection and testing to be carried out are summarized in Table 10.

Table 10 — Summary of inspection and verification testing

Type of inspection and test		Frequency of testing	Refer to	Test category	
				1	2
Mandatory tests	Cast analysis	one per cast	8.2.1 - 11.1	X	X
	Tensile test at ambient temperature	one per sample tube	8.3 - 11.2.1	X	X
	Flattening test for $D < 600$ mm and T/D ratio $\leq 0,15$ but $T \leq 40$ mm ^a or Ring tensile test for $D > 150$ mm and $T \leq 40$ mm		8.3 - 11.3 - 11.4	X	X
	Drift expanding test for $D \leq 150$ mm and $T \leq 10$ mm ^a or Ring expanding test for $D \leq 114,3$ mm and $T \leq 12,5$ mm		8.3 - 11.5 - 11.6	X	X
	Impact test at low temperature		8.3 - 11.7	X	X
	Leak tightness inspection		each tube	8.4.2. - 11.8	X
	Dimensional inspection	8.7 - 11.9		X	X
	Visual examination	11.10		X	X
	NDT for the detection of longitudinal imperfections	each tube	8.4.2.2 - 11.11.1	--	X
	Material identification of alloy steel		11.12	X	X
	Optional tests	Product analysis (Option 3)	one per cast	8.2.2 - 11.1	X
Wall thickness measurement away from tube ends (Option 11)		See 11.9		X	X
NDT for the detection of transverse imperfections (Option 5)		each tube	8.4.2.2 - 11.11.2	--	X
NDT for the detection of laminar imperfections (Option 6)			8.4.2.2 - 11.11.3	--	X
^a The choice of flattening test or ring tensile test and of drift expanding test or ring expanding test is at the manufacturer's discretion.					

10 Sampling

10.1 Frequency of tests

10.1.1 Test unit

A test unit shall comprise tubes of the same specified diameter and wall thickness, the same steel grade, the same cast, the same manufacturing process, subjected to the same finishing treatment in a continuous furnace or heat treated in the same furnace charge in a batch-type furnace.

The number of tubes per test unit shall conform to Table 11:

The manufacturing length (e.g. the rolled length after the normalizing forming process) may differ from the delivery length providing there is no additional HT after cutting the manufacturing lengths into individual lengths.

Table 11 — Number of tubes per test unit

Outside diameter D mm	Maximum number of tubes per test unit
$D \leq 114,3$	200
$114,3 < D \leq 323,9$	100
$D > 323,9$	50

10.1.2 Number of sample tubes per test unit

The following number of sample tubes shall be selected from each test unit:

- test category 1: one sample tube;
- test category 2: two sample tubes; when the total number of tubes is less than 20, only one sample tube.

10.2 Preparation of samples and test pieces

10.2.1 Selection and preparation of samples for product analysis

Samples for product analysis shall be taken from the test pieces or samples for mechanical testing or from the whole wall thickness of the tube at the same location as the mechanical test samples in accordance with EN ISO 14284.

10.2.2 Location, orientation and preparation of samples and test pieces for mechanical tests

10.2.2.1 General

Samples and test pieces shall be taken at the tube ends and in accordance with the requirements of EN ISO 377.

10.2.2.2 Test pieces for tensile tests

The test pieces for the tensile tests shall be prepared in accordance with EN ISO 6892-1.

At the manufacturer's discretion:

- for tubes with an outside diameter $D \leq 219,1$ mm, the test piece shall be either a full tube section or a strip section and shall be taken in a direction longitudinal to the axis of the tube;
- for tubes with an outside diameter $D > 219,1$ mm, the test piece shall either be a machined test piece with circular cross section from an unflattened sample or a strip section and be taken in a direction either longitudinal or transverse to the axis of the tube.

10.2.2.3 Test pieces for the flattening test, ring tensile test, drift expanding test and ring expanding test

The test pieces for the flattening test, ring tensile test, drift expanding test and the ring expanding test shall consist of a full tube section in accordance with EN ISO 8492, EN ISO 8496, EN ISO 8493 or EN ISO 8495, respectively.

10.2.2.4 Test pieces for impact test

Three standard Charpy V-notch test pieces shall be prepared in accordance with EN ISO 148-1. If the wall thickness is such that standard test pieces cannot be produced without flattening of the section, then test pieces of width less than 10 mm, but not less than 5 mm shall be prepared; the largest obtainable width shall be used.

Where test pieces of at least 5 mm width cannot be obtained, the tubes shall not be subject to impact testing.

The test pieces shall be taken transverse to the tube axis unless D_{\min} , as calculated by the following formula, is greater than the specified outside diameter, in which case longitudinal test pieces shall be used:

$$D_{\min} = (T-5) + [756,25 / (T-5)] \quad (1)$$

The test pieces shall be prepared such that the axis of the notch is perpendicular to the surface of the tube; see Figure 2.

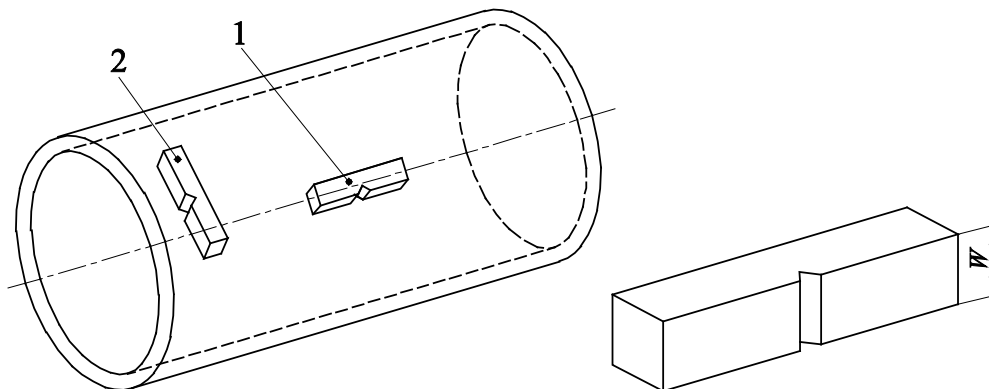

Key

- 1 longitudinal test piece
- 2 transverse test piece
- w specimen width

Figure 2 — Impact test piece orientation

11 Verification test methods

11.1 Chemical analysis

The elements to be determined and reported shall be those specified in Table 2. The choice of a suitable physical or chemical analytical method for the analysis shall be at the discretion of the manufacturer. In cases of dispute, the method used shall be agreed between the manufacturer and the purchaser, taking into account CEN/TR 10261.

11.2 Tensile test

The test shall be carried out at room temperature in accordance with EN ISO 6892-1, and the following determined:

- the tensile strength (R_m);
- the upper yield strength (R_{eH}) or if a yield phenomenon is not present the 0,2 % proof strength ($R_{p0,2}$);
- the percentage elongation after fracture with a reference to a gauge length (L_0) of $5,65 \cdot \sqrt{S_0}$; if a non-proportional test piece is used, the percentage elongation value shall be converted to the value for a gauge length $L_0 = 5,65 \cdot \sqrt{S_0}$ using the conversion tables in EN ISO 2566-1.

11.3 Flattening test

The test shall be carried out in accordance with EN ISO 8492.

The tube section shall be flattened in a press until the distance H between the platens reaches the value given by the following formula:

$$H = \frac{(1 + C)}{C + (T / D)} x T \quad (2)$$

where

H is the distance between platens, in millimetres, to be measured under load;

D is the specified outside diameter, in millimetres;

T is the specified wall thickness, in millimetres;

C is the constant factor of deformation, the value of which is given in Table 12.

Table 12 — Flattening test Constant factor of deformation C

Steel grade		C
Steel name	Steel number	
P 215NL	1.0451	0,09
P 255QL	1.0452	0,09
P 265NL	1.0453	0,07
26CrMo4-2	1.7219	0,06
11MnNi5-3	1.6212	0,07
13MnNi6-3	1.6217	0,07
12Ni14	1.5637	0,08
X12Ni5	1.5680	0,06
X10Ni9	1.5682	0,06

After testing, the test piece shall be free from cracks or breaks. However, slight incipient cracks at its edges shall not be regarded as justification for rejection.

11.4 Ring tensile test

The test shall be carried out in accordance with EN ISO 8496.

The tube section shall be subjected to strain in the circumferential direction until fracture occurs.

After fracture the test pieces shall not show any visible cracks without the use of magnifying aids (excluding the fracture point).

11.5 Drift expanding test

The test shall be carried out in accordance with EN ISO 8493.

The tube section shall be expanded with a 60° conical tool until the percentage increase in outside diameter shown in Table 13 is reached.

Table 13 — Drift expanding test requirements

Steel grade	% increase in outside diameter for d/D^a		
	$\leq 0,6$	$> 0,6 \leq 0,8$	$> 0,8$
All steel grades	8	10	15

^a $d = D - 2T$

After testing, the test piece shall be free from cracks or breaks. However, slight incipient cracks at its edges shall not be regarded as justification for rejection.

11.6 Ring expanding test

The test shall be carried out in accordance with EN ISO 8495.

The tube section shall be expanded with a conical tool until it breaks. The surface outside the fracture zone shall be free from cracks or breaks. However, slight incipient cracks at its edges shall not be regarded as justification for rejection.

11.7 Impact test

11.7.1 The test shall be carried out (but see 10.2.2.4) in accordance with EN ISO 148-1, at the lowest temperature specified in Table 5 for the steel grade concerned.

11.7.2 The mean value of the three test pieces shall meet the requirements given in Table 5. One individual value may be below the specified value, provided that it is not less than 70 % of that value.

11.7.3 If the width (W) of the test piece is less than 10 mm, the measured impact energy (KV_p) shall be converted to the calculated impact energy (KV_c) using the following formula:

$$KV_c = \frac{10 \times KV_p}{W} \quad (3)$$

where

- KV_c is the calculated impact energy, in joules;
- KV_p is the measured impact energy, in joules;
- W is the width of the test piece, in millimetres.

The calculated impact energy KV_c shall conform to with the requirements given in 11.7.2.

11.7.4 If the requirements of 11.7.2 are not met, then an additional set of three test pieces may be taken at the discretion of the manufacturer from the same sample and tested. To consider the test unit as conforming, after testing the second set, the following conditions shall be satisfied simultaneously:

- the average value of the six tests shall be equal to or greater than the specified minimum average value;
- not more than two of the six individual values may be lower than the specified minimum average value;
- not more than one of the six individual values may be lower than 70 % of the specified minimum average value.

11.7.5 The dimensions in millimetres of the test pieces, the measured impact energy values and the resulting average value shall be reported.

11.8 Leak tightness test

11.8.1 Hydrostatic test

The hydrostatic test shall be carried out at a test pressure of 70 bar¹⁾ or at a test pressure P calculated using the following formula, whichever is lower:

1) 1 bar = 100 kPa.

$$P = 20 \frac{S \times T}{D} \quad (4)$$

where

P is the test pressure, in bar;

D is the specified outside diameter, in millimetres;

T is the specified wall thickness, in millimetres;

S is the stress, in MPa, corresponding to 70 % of the specified minimum yield strength (see Table 4) for the steel grade concerned.

The test pressure shall be held for not less than 5 s for tubes with an outside diameter D less than or equal to 457 mm and for not less than 10 s for tubes with an outside diameter D greater than 457 mm.

The tube shall withstand the test without showing leakage.

NOTE This hydrostatic leak-tightness test is not a strength test.

Option 10: A test pressure different from that specified in 11.8.1 and corresponding to stresses below 90 % of the specified minimum yield strength (see Table 4) for the steel grade concerned is specified.

11.8.2 Electromagnetic test

The test shall be carried out in accordance with EN ISO 10893-1.

11.9 Dimensional inspection

Specified dimensions, including straightness, shall be verified.

The outside diameter shall be measured at the tube ends. For tubes with outside diameter $D \geq 406,4$ mm, the diameter may be measured using a circumference tape.

Unless option 11 is specified, the wall thickness shall be measured at both tube ends.

Option 11: The wall thickness shall be measured away from the tube ends in accordance with an agreed procedure.

11.10 Visual examination

Tubes shall be visually examined to ensure conformity to the requirements of 8.4.1.

11.11 Non-Destructive Testing

11.11.1 Tubes of test category 2 shall be subjected to Non-Destructive Testing for the detection of longitudinal imperfections, in accordance with EN ISO 10893-10, to acceptance level U2 sub-category C or EN ISO 10893-3 acceptance level F2.

Unless option 12 is specified, the selection of the method is at the discretion of the manufacture.

Option 12: The test method is specified by the purchaser.

Regions at the tube ends not automatically tested shall either be subjected to manual/semi-automatic ultrasonic testing in accordance with EN ISO 10893-10 to acceptance level U 2 sub-category C or be cropped off.

11.11.2 If option 5 (see 8.4.2.2) is specified, the tubes shall be submitted to ultrasonic testing for the detection of transverse imperfections in accordance with EN ISO 10893-10 to acceptance level U2 sub-category C.

11.11.3 If option 6 (see 8.4.2.2) is specified the tubes shall be submitted to ultrasonic testing for the detection of the laminar imperfections in accordance with EN ISO 10893-8 to acceptance level U2.

11.12 Material identification

Each tube made from alloy steel (see 5.1) shall be tested by an appropriate method to ensure that the correct grade is being supplied.

11.13 Retests, sorting and reprocessing

For retest, sorting and reprocessing the requirements of EN 10021 shall apply.

12 Marking

12.1 Marking to be applied

The marking shall be indelibly marked on each tube at least at one end. For tubes with outside diameter $D \leq 51$ mm, the marking on tubes may be replaced by the marking on a label attached to the bundle or box.

The marking shall include the following information:

- the manufacturer's name or trade mark ;
- the number of this European Standard and the steel name (see 5.2);
- the test category in case of non-alloy steel grades;
- the cast number or a code number;
- the mark of the inspection representative;
- an identification number (e.g. order or item number) which permits the correlation of the product or delivery unit to the related documents.

Example of marking:

EXAMPLE X - EN 10216-4 - P265NL - TC1 - Y - Z₁ - Z₂

where

- X is the manufacturer's mark;
- TC1 is the designation of the test category 1;
- Y is the cast number or a code number;
- Z₁ is the mark of the inspection representative;
- Z₂ is the identification number.

12.2 Additional marking

Option 13: Additional marking, as agreed upon at the time of enquiry and order, shall be applied.

13 Protection

The tubes shall be delivered without a temporary protective coating.

Option 14: *A temporary protective coating or durable coating and/or lining shall be applied.*

Annex A (informative)

Technical changes from the previous edition

A.1 Introduction

This informative annex is intended to guide the user to places where significant technical changes have been introduced into the previous edition of this European Standard. Editorial changes are not included in this annex. References refer to the previous edition.

While this annex is intended to be comprehensive, the user should satisfy himself that he fully understands the changes which have been made. The user is ultimately responsible for recognizing any differences between this edition and the previous edition of the document.

A.2 Technical changes

- 1 Scope
- 2 Normative references
- 6 Information to be supplied by the purchaser
 - 6.2 Options [4) and 9)]
- 7 Manufacturing process
 - 7.1 Steelmaking process
- 8 Requirements
 - 8.3 Mechanical properties
 - 8.6 Preparation of ends
- 9 Inspections
 - 9.1 Types of inspections
 - 9.2 Inspection documents (9.2.1)
 - 9.3 Summary of inspection and verification testing
- 10 Sampling
 - 10.1 Frequency of tests (10.1.1)
- Annex ZA (ZA.1)

Annex ZA (informative)

Relationship between this European Standard and the Essential Requirements of EU Directive 97/23/EC

This European Standard has been prepared under a mandate given to CEN by the European Commission and the European Free Trade Association to provide a means of conforming to Essential Requirements of the New Approach Directive 97/23/EC.

Once this standard is cited in the Official Journal of the European Union under that Directive and has been implemented as a national standard in at least one Member State, compliance with the clauses of this standard given in Table ZA.1 confers, within the limits of the scope of this standard, a presumption of conformity with the corresponding Essential Requirements of that Directive and associated EFTA regulations.

Table ZA.1 — Correspondence between this European Standard and the essential requirements of the EU Directive 97/23/EC

Clauses/subclauses of this EN	Essential Requirements (ERs) of the Directive 97/23/EC	Qualifying remarks/Notes
8.3	Annex I, 4.1a	Appropriate material properties
7.1 and 8.2	Annex I, 4.1 c	Ageing
7.2 and 8.4	Annex I, 4.1d	Suitable for the processing procedures
9 and 10	Annex I, 4.3	Documentation

WARNING: Other requirements and other EU Directives may be applicable to the product(s) falling within the scope of this standard.

Bibliography

EN ISO 9712:2012, *Non-destructive testing - Qualification and certification of NDT personnel (ISO 9712:2012)*

British Standards Institution (BSI)

BSI is the national body responsible for preparing British Standards and other standards-related publications, information and services.

BSI is incorporated by Royal Charter. British Standards and other standardization products are published by BSI Standards Limited.

About us

We bring together business, industry, government, consumers, innovators and others to shape their combined experience and expertise into standards-based solutions.

The knowledge embodied in our standards has been carefully assembled in a dependable format and refined through our open consultation process. Organizations of all sizes and across all sectors choose standards to help them achieve their goals.

Information on standards

We can provide you with the knowledge that your organization needs to succeed. Find out more about British Standards by visiting our website at bsigroup.com/standards or contacting our Customer Services team or Knowledge Centre.

Buying standards

You can buy and download PDF versions of BSI publications, including British and adopted European and international standards, through our website at bsigroup.com/shop, where hard copies can also be purchased.

If you need international and foreign standards from other Standards Development Organizations, hard copies can be ordered from our Customer Services team.

Subscriptions

Our range of subscription services are designed to make using standards easier for you. For further information on our subscription products go to bsigroup.com/subscriptions.

With **British Standards Online (BSOL)** you'll have instant access to over 55,000 British and adopted European and international standards from your desktop. It's available 24/7 and is refreshed daily so you'll always be up to date.

You can keep in touch with standards developments and receive substantial discounts on the purchase price of standards, both in single copy and subscription format, by becoming a **BSI Subscribing Member**.

PLUS is an updating service exclusive to BSI Subscribing Members. You will automatically receive the latest hard copy of your standards when they're revised or replaced.

To find out more about becoming a BSI Subscribing Member and the benefits of membership, please visit bsigroup.com/shop.

With a **Multi-User Network Licence (MUNL)** you are able to host standards publications on your intranet. Licences can cover as few or as many users as you wish. With updates supplied as soon as they're available, you can be sure your documentation is current. For further information, email bsmusales@bsigroup.com.

BSI Group Headquarters

389 Chiswick High Road London W4 4AL UK

Revisions

Our British Standards and other publications are updated by amendment or revision.

We continually improve the quality of our products and services to benefit your business. If you find an inaccuracy or ambiguity within a British Standard or other BSI publication please inform the Knowledge Centre.

Copyright

All the data, software and documentation set out in all British Standards and other BSI publications are the property of and copyrighted by BSI, or some person or entity that owns copyright in the information used (such as the international standardization bodies) and has formally licensed such information to BSI for commercial publication and use. Except as permitted under the Copyright, Designs and Patents Act 1988 no extract may be reproduced, stored in a retrieval system or transmitted in any form or by any means – electronic, photocopying, recording or otherwise – without prior written permission from BSI. Details and advice can be obtained from the Copyright & Licensing Department.

Useful Contacts:

Customer Services

Tel: +44 845 086 9001

Email (orders): orders@bsigroup.com

Email (enquiries): cservices@bsigroup.com

Subscriptions

Tel: +44 845 086 9001

Email: subscriptions@bsigroup.com

Knowledge Centre

Tel: +44 20 8996 7004

Email: knowledgecentre@bsigroup.com

Copyright & Licensing

Tel: +44 20 8996 7070

Email: copyright@bsigroup.com



...making excellence a habit.™