

# Steel products with improved deformation properties perpendicular to the surface of the product — Technical delivery conditions

The European Standard EN 10164:2004 has the status of a  
British Standard

ICS 77.140.70



## National foreword

This British Standard is the official English language version of EN 10164:2004. It supersedes BS EN 10164:1993 which is withdrawn.

The UK participation in its preparation was entrusted to Technical Committee ISE/12, Structural steels, which has the responsibility to:

- aid enquirers to understand the text;
- present to the responsible international/European committee any enquiries on the interpretation, or proposals for change, and keep the UK interests informed;
- monitor related international and European developments and promulgate them in the UK.

A list of organizations represented on this committee can be obtained on request to its secretary.

### Cross-references

The British Standards which implement international or European publications referred to in this document may be found in the *BSI Catalogue* under the section entitled “International Standards Correspondence Index”, or by using the “Search” facility of the *BSI Electronic Catalogue* or of British Standards Online.

This publication does not purport to include all the necessary provisions of a contract. Users are responsible for its correct application.

**Compliance with a British Standard does not of itself confer immunity from legal obligations.**

### Summary of pages

This document comprises a front cover, an inside front cover, the EN title page, pages 2 to 14, an inside back cover and a back cover.

The BSI copyright notice displayed in this document indicates when the document was last issued.

### Amendments issued since publication

Amd. No.	Date	Comments

This British Standard was published under the authority of the Standards Policy and Strategy Committee on 16 December 2004

© BSI 16 December 2004

ISBN 0 580 45118 6



English version

**Steel products with improved deformation properties  
perpendicular to the surface of the product - Technical delivery  
conditions**

Aciers de construction à caractéristiques de déformation  
améliorées dans le sens perpendiculaire à la surface du  
produit - Conditions techniques de livraison

Stahlerzeugnisse mit verbesserten  
Verformungseigenschaften senkrecht zur  
Erzeugnisoberfläche - Technische Lieferbedingungen

This European Standard was approved by CEN on 4 November 2004.

CEN members are bound to comply with the CEN/CENELEC Internal Regulations which stipulate the conditions for giving this European Standard the status of a national standard without any alteration. Up-to-date lists and bibliographical references concerning such national standards may be obtained on application to the Central Secretariat or to any CEN member.

This European Standard exists in three official versions (English, French, German). A version in any other language made by translation under the responsibility of a CEN member into its own language and notified to the Central Secretariat has the same status as the official versions.

CEN members are the national standards bodies of Austria, Belgium, Cyprus, Czech Republic, Denmark, Estonia, Finland, France, Germany, Greece, Hungary, Iceland, Ireland, Italy, Latvia, Lithuania, Luxembourg, Malta, Netherlands, Norway, Poland, Portugal, Slovakia, Slovenia, Spain, Sweden, Switzerland and United Kingdom.



EUROPEAN COMMITTEE FOR STANDARDIZATION  
COMITÉ EUROPÉEN DE NORMALISATION  
EUROPÄISCHES KOMITEE FÜR NORMUNG

Management Centre: rue de Stassart, 36 B-1050 Brussels

# Contents

	Page
Foreword.....	3
Introduction .....	4
1 Scope .....	5
2 Normative references .....	5
3 Designation .....	5
4 Information to be supplied by the purchaser .....	6
4.1 Mandatory information .....	6
4.2 Options .....	6
5 Requirements .....	6
5.1 Reduction of area.....	6
5.2 Ultrasonic testing.....	7
6 Inspection .....	7
6.1 Test units .....	7
6.1.1 General.....	7
6.1.2 Flat products .....	7
6.1.3 Sections .....	8
7 Preparation of samples and test pieces .....	8
7.1 Location and orientation of samples and test pieces.....	8
7.1.1 Preparation of samples .....	8
7.1.2 Preparation of test pieces .....	9
7.2 Identification of samples and test pieces .....	12
8 Test method.....	12
8.1 Tensile test .....	12
8.2 Retest .....	13
8.3 Invalidation of tests .....	13
9 Marking, labelling and packaging .....	13
10 Complaints .....	13
11 Options (see 4.2).....	13
Bibliography.....	14

Licensed Copy: Institute Of Technology Tallaght, Institute of Technology, Thu May 24 12:20:15 GMT+00:00 2007, Uncontrolled Copy, (c) BSI



## Foreword

This document (EN 10164:2004) has been prepared by Technical Committee ECISS/TC 10 “Structural steels – Grades and qualities”, the secretariat of which is held by NEN.

This European Standard shall be given the status of a national standard, either by publication of an identical text or by endorsement, at the latest by June 2005, and conflicting national standards shall be withdrawn at the latest by June 2005.

This document supersedes EN 10164:1993, *Steel products with improved deformation properties perpendicular to the surface of the product - Technical delivery conditions*.

During the 5 year review of EN 10164:1993 the members of ECISS/TC 10 agreed to revise EN 10164:1993. It was asked to actualise the normative references and to bring the text in line with “Iron and steel standardization – Model for a product standard”. In the scope the product thickness is increased to 400 mm to be in line with EN 10025-2. The upper yield strength is increased to 960 MPa to be in line with EN 10025-6.

This document includes a Bibliography.

According to the CEN/CENELEC Internal Regulations, the national standards organizations of the following countries are bound to implement this European Standard: Austria, Belgium, Cyprus, Czech Republic, Denmark, Estonia, Finland, France, Germany, Greece, Hungary, Iceland, Ireland, Italy, Latvia, Lithuania, Luxembourg, Malta, Netherlands, Norway, Poland, Portugal, Slovakia, Slovenia, Spain, Sweden, Switzerland and United Kingdom.

This document is now  
**POOBLIC**

## Introduction

Flat products and sections of steel as normally manufactured have deformation properties perpendicular to the surface (through thickness) which are different from those obtained in the surface direction. This anisotropy of the properties may lead to difficulties in welded structures, for instance lamellar tearing.

It is, however, possible to improve the through thickness properties by using additional steel making procedures.

Through thickness properties are characterized in this document by specified values for reduction of area in a through thickness tensile test.

There is no direct relationship between these values and the integrity of structures, because the risk of lamellar tearing is also basically influenced by the type of structure, weld design and welding procedure. The minimum values for reduction of area in this document cannot therefore by themselves be regarded as ensuring safety against occurrence of lamellar tearing.

However the reduction of area is a good general guide to lamellar tear resistance i.e. the risk of lamellar tearing decreases with increased reduction of area in the through thickness tensile test.



## 1 Scope

This document specifies through thickness properties and associated test methods for flat products and sections of steel.

This document may be applied as a supplement to all product standards for flat products and sections of fully killed steels, except stainless steels. It covers products having a thickness between 15 mm and 400 mm inclusive of steels with a specified minimum upper yield strength  $R_{eH}$  or proof strength  $R_{p0,2} \leq 960 \text{ MPa}^1$  for which improved through thickness properties are required.

The application of this document to other product thicknesses and other steel types shall be the subject of agreement at the time of the order.

See option 1.

## 2 Normative references

The following referenced documents are indispensable for the application of this document. For dated references, only the edition cited applies. For undated references, the latest edition of the referenced document (including any amendments) applies.

EN 10002-1, *Metallic materials - Tensile testing - Part 1: Method of test at ambient temperature*

EN 10021, *General technical delivery requirements for steel and iron products*

EN 10160, *Ultrasonic testing of steel flat product of thickness equal to or greater than 6 mm (reflection method)*

EN 10306:2001, *Iron and steel - Ultrasonic testing of H beams with parallel flanges and IPE beams*

## 3 Designation

Products with requirements for improved deformation properties perpendicular to the surface of the product shall be designated as follows:

- the designation of the steel (according to the relevant product standard);
- the number of this document (EN 10164);
- the designation of the quality class (according to Table 1).

EXAMPLE Steel according to EN 10025-3 of the grade S355N (1.0545) with requirements for improved deformation properties perpendicular to the surface of the product according to EN 10164 of class Z25,

Steel EN 10025-3 - S355N + EN 10164 - Z25

or

Steel EN 10025-3 – 1.0545 + EN 10164 - Z25

---

1) 1 MPa = 1 N/mm<sup>2</sup>

## 4 Information to be supplied by the purchaser

### 4.1 Mandatory information

The following information shall be supplied by the purchaser at the time of the order:

- a) the designation of the steel (according to the relevant product standard);
- b) the designation of the quality class (see Table 1).

Where no specific choice is made by the purchaser the supplier shall refer back to the purchaser.

### 4.2 Options

A number of options are specified in Clause 11. In the event that the purchaser does not indicate his wish to implement any of these options, the supplier shall supply in accordance with the basic specification.

## 5 Requirements

### 5.1 Reduction of area

Table 1 gives minimum values for reduction of area for the specified quality classes.

NOTE Reduction of area (Z) is defined in EN 10002-1 as:

$$\left( \frac{S_o - S_u}{S_o} \right) \times 100$$

where

$S_o$  is the original cross-sectional area of the parallel length;

$S_u$  is the minimum cross-sectional area after fracture.

For flat products the minimum values for reduction of area apply to the whole product.

For sections the minimum values for reduction of area apply to either the flange or the web depending on where the samples are taken (see 7.1.1.3).

**Table 1 — Quality classes and minimum values for the reduction of area**

Quality class	Reduction of area in %	
	Minimum average value of three tests	Minimum individual value
Z15	15	10
Z25	25	15
Z35	35	25



## 5.2 Ultrasonic testing

Flat products shall be submitted to an ultrasonic examination in accordance with the requirements of EN 10160. Sections shall be submitted to an ultrasonic examination in accordance with the requirements of EN 10306.

Unless otherwise agreed at the time of the order flat products shall meet the requirements of class S1 in accordance with EN 10160, sections shall meet the requirements of class 2.3 in accordance with EN 10306:2001, Table 2.

See option 2.

NOTE Application of the normal ultrasonic techniques does not give information about the susceptibility to lamellar tearing.

## 6 Inspection

### 6.1 Test units

#### 6.1.1 General

Each consignment shall be subdivided into test units in accordance with 6.1.2 and 6.1.3.

#### 6.1.2 Flat products

The test units for flat products of the quality classes Z15, Z25 and Z35 based on the sulphur content of the ladle analysis are given in Table 2.

**Table 2 — Test units for flat products**

Quality class	Test unit for		
	S > 0,005 % <sup>a</sup>		S ≤ 0,005 % <sup>a</sup>
	Parent plate or coil <sup>b</sup>	max. 40 t <sup>c</sup>	Cast <sup>d</sup>
Z15	if agreed	x <sup>e</sup>	x
Z25	x	-	x <sup>e</sup>
Z35	x	-	x <sup>e</sup>
<sup>a</sup> Ladle analysis. <sup>b</sup> Coil applies to wide strip, narrow strip and slit strip. <sup>c</sup> Or part thereof of products of the same cast with the same heat treatment. <sup>d</sup> Products with the same heat treatment. <sup>e</sup> Unless otherwise agreed at the time of the order. See option 3			

This document is now  
**POOBLIC**

### 6.1.3 Sections

The test unit for sections shall consist of products from the same cast having been subjected to the same heat treatment with a total mass of max. 40 t or part thereof.

## 7 Preparation of samples and test pieces

### 7.1 Location and orientation of samples and test pieces

#### 7.1.1 Preparation of samples

**7.1.1.1** One sample sufficient to enable six test pieces to be machined shall be taken from each test unit according to 6.1.2.

**7.1.1.2** For flat products according to 6.1.2 the sample shall be taken from one end of the product. These samples shall be taken for ingot cast material on the longitudinal axis of the product and for continuously cast material they may be taken at the manufacturer's discretion either on the longitudinal axis of the product or from approximately midway between the edge and the longitudinal axis of the products.

**7.1.1.3** For sections the sample shall be taken from one end of the product. The sampling position shall be the flange unless otherwise agreed at the time of the order. The location of the sample is indicated in Figure 1.

See option 4.



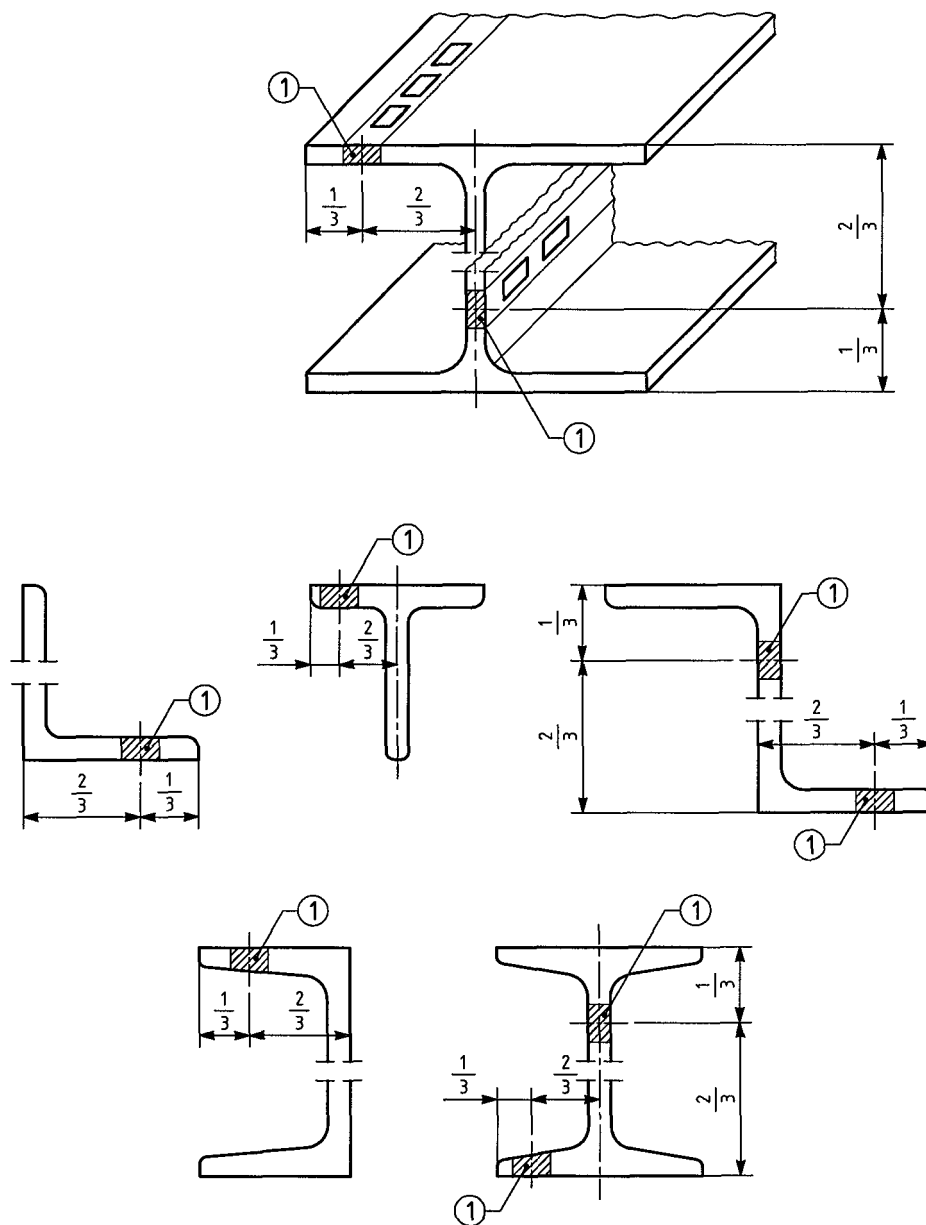

### Key

- 1 Location of samples

**Figure 1 — Location of samples for sections**

**7.1.1.4** Only three tensile test pieces shall be machined from the sample, the remaining test pieces being kept in reserve in the event that supplementary testing is required (see 8.1.3).

### 7.1.2 Preparation of test pieces

#### 7.1.2.1 Specimen

From the sample obtained in accordance with 7.1, three full thickness specimens shall be taken. The cross-section of each specimen shall be sufficient to permit the removal of any resultant heat affected or work

hardened zone during machining of the final test pieces. The balance of the sample shall be kept in reserve in the event that additional tests are required.

### 7.1.2.2 Test pieces with or without extension pieces

#### 7.1.2.2.1 General

From the specimens obtained in accordance with 7.1.2.1 test pieces with or without extension pieces shall be prepared in accordance with the procedures given in 7.1.2.2.2 and 7.1.2.2.3, as appropriate.

Extension pieces are:

- mandatory for  $15 \text{ mm} \leq t \leq 20 \text{ mm}$ , where  $t$  is the product thickness;
- optional for  $20 \text{ mm} < t \leq 80 \text{ mm}$ , where  $t$  is the product thickness;
- not acceptable for  $t > 80 \text{ mm}$ , where  $t$  is the product thickness.

The axis of the test pieces shall be perpendicular to the surface.

#### 7.1.2.2.2 Procedure for test pieces with extension pieces (see Figure 2)

Prior to any welding taking place all rust, scale and grease shall be removed from the contact surfaces of the specimen.

- a) Extension pieces are welded to both surfaces of the specimen using friction welding, or another suitable method, in such a way as to ensure a minimum heat affected zone.

For specimens from sections with non-parallel surfaces, one surface shall be machined parallel to the other. In the case of I beams with tapered flanges the inside surface shall always be machined.

- b) The test piece shall have the following diameter,  $d_o$ :

- $d_o = 6 \text{ mm}$  or  $10 \text{ mm}$  for  $15 \text{ mm} \leq t \leq 25 \text{ mm}$ , where  $t$  is the product thickness;
- $d_o = 10 \text{ mm}$  for  $25 \text{ mm} < t \leq 80 \text{ mm}$ , where  $t$  is the product thickness.

- c) The parallel length,  $L_c$ , of the test piece shall be at least  $1,5 d_o$  and shall not exceed  $80 \text{ mm}$ . The heat affected zone shall be outside  $L_c$ .

#### 7.1.2.2.3 Procedure for test pieces without extension pieces (see Figures 3 and 4)

- a) The test piece shall have the following diameter,  $d_o$ :

- $d_o = 6 \text{ mm}$  or  $10 \text{ mm}$  for  $20 \text{ mm} \leq t \leq 40 \text{ mm}$ , where  $t$  is the product thickness;
- $d_o = 10 \text{ mm}$  for  $40 \text{ mm} < t \leq 400 \text{ mm}$ , where  $t$  is the product thickness.

- b) The parallel length,  $L_c$ , of the test piece shall be at least  $1,5 d_o$  and shall not exceed  $80 \text{ mm}$ .

- c) For products  $\leq 80 \text{ mm}$  the total length,  $L_t$ , of the test piece shall be equal to the full product thickness,  $t$ .

- d) For products  $> 80 \text{ mm}$  and  $\leq 400 \text{ mm}$  the total length,  $L_t$ , of the test piece shall be such that  $L_c$  contains the  $\frac{1}{4}$  thickness position of the product.

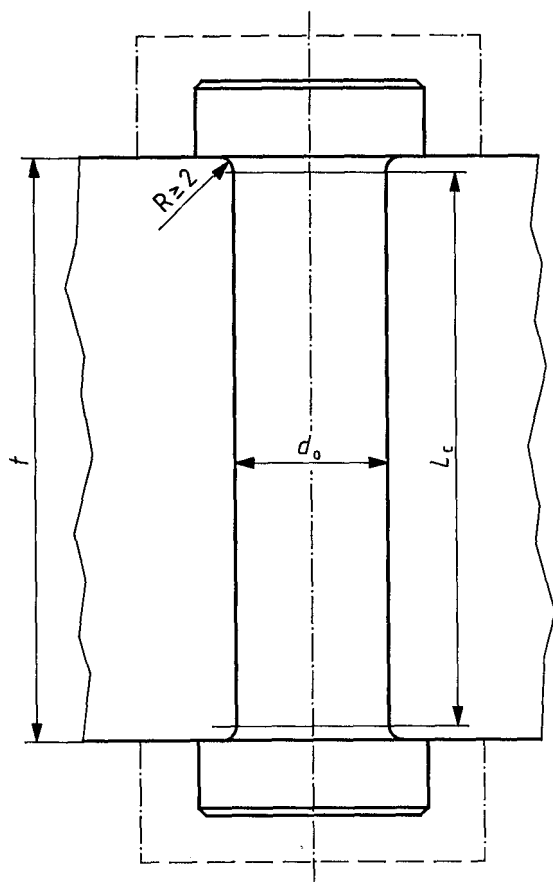

Figure 1 — Type and preparation of test pieces with two extension pieces for product thickness  $t$ ,  $15 \text{ mm} \leq t \leq 80 \text{ mm}$

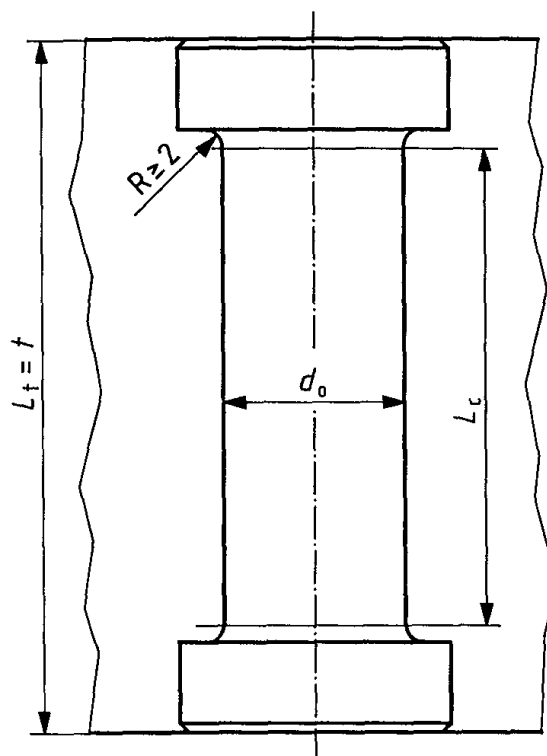

Figure 2 — Type and preparation of test pieces without extension pieces for product thickness  $t$ ,  $20 \text{ mm} < t \leq 80 \text{ mm}$

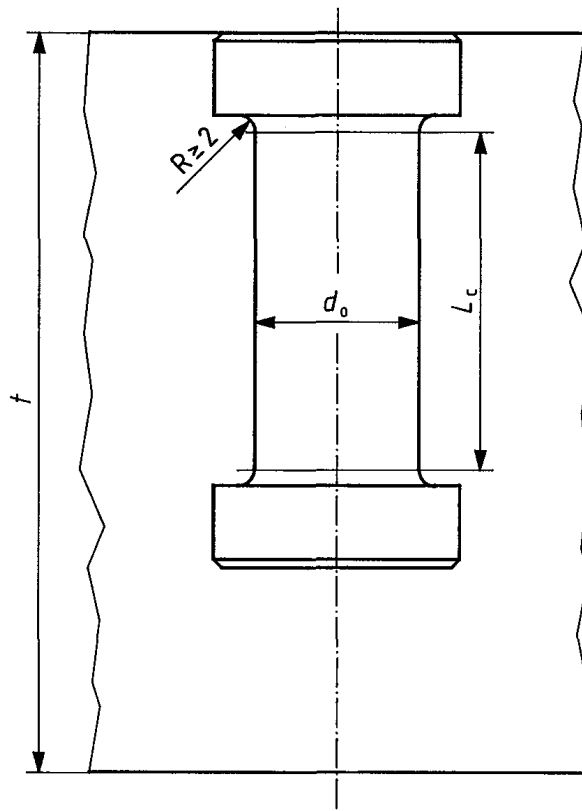

Figure 4 — Type and preparation of test pieces without extension pieces for product thickness  $t$ ,  
 $80 \text{ mm} < t \leq 400 \text{ mm}$

## 7.2 Identification of samples and test pieces

Samples and test pieces shall be traceable to the original product and to the location and orientation in the product.

## 8 Test method

### 8.1 Tensile test

**8.1.1** The tensile test shall be carried out in accordance with EN 10002-1 and the reduction of area shall be determined in accordance with EN 10002-1. The assessment of results is based on a sequential method (as defined in EN 10021).

**8.1.2** The average value of a set of three test pieces (see 7.1.1.4) shall meet the specified requirement (see 5.1). One individual value may be below the specified minimum average value, provided that it is not less than the specified minimum individual value.

**8.1.3** If the conditions under 8.1.2 are not satisfied then an additional set of three test pieces shall be taken from the same sample and tested. To consider the test unit as conforming, after testing the second set, the following conditions shall be satisfied simultaneously:

- the average value of six tests shall be equal to or greater than the specified minimum average value;
- not more than two of six individual values may be lower than the specified minimum average value;
- not more than one of six individual values may be lower than the specified minimum individual value.

**8.1.4** If these conditions are not satisfied, the sample product is rejected and retests are carried out on the remainder of the test unit, if applicable (see 8.2).

## 8.2 Retest

Except in cases where the test unit is the parent plate or the coil (6.1.2) a new set of three tests shall be carried out on each of two different products from the remainder of the test unit, those two series of tests shall meet the requirements. In this case 8.1.3 and 8.1.4 no longer apply.

If one of these retests does not meet the requirements of this document, the remainder of the test unit shall be retested product by product.

Each product on which the tests do not meet the requirements shall be rejected.

## 8.3 Invalidation of tests

The requirements of EN 10021 shall apply with the addition that a fracture in the weld or in the heat affected zone is also a reason for invalidation.

## 9 Marking, labelling and packaging

The product shall be marked according to the relevant product standard or specification with the addition of the quality class as specified in this document (see 5.1).

EXAMPLE S355N+Z15

## 10 Complaints

With regard to any claims and action arising, EN 10021 shall apply.

## 11 Options (see 4.2)

The following options apply:

- 1) Other product thicknesses and steel types may be agreed (see Clause 1).
- 2) Ultrasonic tested flat products shall meet the requirements other than class S1 in accordance with EN 10160 and sections shall meet the requirements other than class 2.3 in accordance with EN 10306:2001, Table 2 (see 5.2).
- 3) Other test units for the flat products indicated in Table 2 by footnote e shall be agreed.
- 4) An other sampling position than the flange shall be agreed (see 7.1.1.3).

## Bibliography

- [1] EN 10025-2, *Hot rolled products of structural steels - Part 2: Technical delivery conditions for non-alloy structural steels*
- [2] EN 10025-3, *Hot rolled products of structural steels - Part 3: Technical delivery conditions for normalized/normalized rolled weldable fine grain structural steels*
- [3] EN 10025-6, *Hot rolled products of structural steels - Part 6: Technical delivery conditions for flat products of high yield strength structural steels in the quenched and tempered condition*



*blank*



## BSI — British Standards Institution

BSI is the independent national body responsible for preparing British Standards. It presents the UK view on standards in Europe and at the international level. It is incorporated by Royal Charter.

### Revisions

British Standards are updated by amendment or revision. Users of British Standards should make sure that they possess the latest amendments or editions.

It is the constant aim of BSI to improve the quality of our products and services. We would be grateful if anyone finding an inaccuracy or ambiguity while using this British Standard would inform the Secretary of the technical committee responsible, the identity of which can be found on the inside front cover.  
Tel: +44 (0)20 8996 9000. Fax: +44 (0)20 8996 7400.

BSI offers members an individual updating service called PLUS which ensures that subscribers automatically receive the latest editions of standards.

### Buying standards

Orders for all BSI, international and foreign standards publications should be addressed to Customer Services. Tel: +44 (0)20 8996 9001.  
Fax: +44 (0)20 8996 7001. Email: [orders@bsi-global.com](mailto:orders@bsi-global.com). Standards are also available from the BSI website at <http://www.bsi-global.com>.

In response to orders for international standards, it is BSI policy to supply the BSI implementation of those that have been published as British Standards, unless otherwise requested.

### Information on standards

BSI provides a wide range of information on national, European and international standards through its Library and its Technical Help to Exporters Service. Various BSI electronic information services are also available which give details on all its products and services. Contact the Information Centre.  
Tel: +44 (0)20 8996 7111. Fax: +44 (0)20 8996 7048. Email: [info@bsi-global.com](mailto:info@bsi-global.com).

Subscribing members of BSI are kept up to date with standards developments and receive substantial discounts on the purchase price of standards. For details of these and other benefits contact Membership Administration.  
Tel: +44 (0)20 8996 7002. Fax: +44 (0)20 8996 7001.  
Email: [membership@bsi-global.com](mailto:membership@bsi-global.com).

Information regarding online access to British Standards via British Standards Online can be found at <http://www.bsi-global.com/bsonline>.

Further information about BSI is available on the BSI website at <http://www.bsi-global.com>.

### Copyright

Copyright subsists in all BSI publications. BSI also holds the copyright, in the UK, of the publications of the international standardization bodies. Except as permitted under the Copyright, Designs and Patents Act 1988 no extract may be reproduced, stored in a retrieval system or transmitted in any form or by any means – electronic, photocopying, recording or otherwise – without prior written permission from BSI.

This does not preclude the free use, in the course of implementing the standard, of necessary details such as symbols, and size, type or grade designations. If these details are to be used for any other purpose than implementation then the prior written permission of BSI must be obtained.

Details and advice can be obtained from the Copyright & Licensing Manager.  
Tel: +44 (0)20 8996 7070. Fax: +44 (0)20 8996 7553.  
Email: [copyright@bsi-global.com](mailto:copyright@bsi-global.com).