

Stainless steel strip for springs — Technical delivery conditions

The European Standard EN 10151:2002 has the status of a
British Standard

ICS 77.140.25

National foreword

This British Standard is the official English language version of EN 10151:2002. It supersedes BS 5770-4:1981 which is withdrawn.

The UK participation in its preparation was entrusted to Technical Committee ISE/30, Stainless steels, which has the responsibility to:

- aid enquirers to understand the text;
- present to the responsible international/European committee any enquiries on the interpretation, or proposals for change, and keep the UK interests informed;
- monitor related international and European developments and promulgate them in the UK.

A list of organizations represented on this committee can be obtained on request to its secretary.

Cross-references

The British Standards which implement international or European publications referred to in this document may be found in the *BSI Catalogue* under the section entitled "International Standards Correspondence Index", or by using the "Search" facility of the *BSI Electronic Catalogue* or of British Standards Online.

This publication does not purport to include all the necessary provisions of a contract. Users are responsible for its correct application.

Compliance with a British Standard does not of itself confer immunity from legal obligations.

Summary of pages

This document comprises a front cover, an inside front cover, the EN title page, pages 2 to 29 and a back cover.

The BSI copyright date displayed in this document indicates when the document was last issued.

Amendments issued since publication

Amd. No.	Date	Comments

This British Standard, having been prepared under the direction of the Engineering Sector Policy and Strategy Committee, was published under the authority of the Standards Policy and Strategy Committee on 26 November 2002

© BSI 26 November 2002

ISBN 0 580 40827 2

ICS 77.140.25

English version

Stainless steel strip for springs - Technical delivery conditions

Bandes pour ressorts en aciers inoxydables - Conditions
techniques de livraison

Federband aus nichtrostenden Stählen - Technische
Lieferbedingungen

This European Standard was approved by CEN on 14 September 2002.

CEN members are bound to comply with the CEN/CENELEC Internal Regulations which stipulate the conditions for giving this European Standard the status of a national standard without any alteration. Up-to-date lists and bibliographical references concerning such national standards may be obtained on application to the Management Centre or to any CEN member.

This European Standard exists in three official versions (English, French, German). A version in any other language made by translation under the responsibility of a CEN member into its own language and notified to the Management Centre has the same status as the official versions.

CEN members are the national standards bodies of Austria, Belgium, Czech Republic, Denmark, Finland, France, Germany, Greece, Iceland, Ireland, Italy, Luxembourg, Malta, Netherlands, Norway, Portugal, Spain, Sweden, Switzerland and United Kingdom.



EUROPEAN COMMITTEE FOR STANDARDIZATION
COMITÉ EUROPÉEN DE NORMALISATION
EUROPÄISCHES KOMITEE FÜR NORMUNG

Management Centre: rue de Stassart, 36 B-1050 Brussels

Contents

	page
Foreword.....	3
1 Scope	4
2 Normative references	4
3 Terms and definitions.....	5
4 Classification and designation	5
4.1 Classification.....	5
4.2 Designation.....	5
4.2.1 Steel names	5
4.2.2 Steel numbers	5
5 Information to be supplied by the purchaser.....	5
5.1 Mandatory information	5
5.2 Options.....	6
6 Manufacturing process	7
6.1 General.....	7
6.2 Delivery	7
6.2.1 Delivery form	7
6.2.2 Delivery condition.....	7
7 Requirements	7
7.1 Chemical composition.....	7
7.2 Mechanical properties	7
7.3 Technological properties and surface condition.....	8
7.4 Internal soundness	8
7.5 Dimensions and tolerances on dimensions.....	8
8 Inspection and testing.....	8
8.1 General.....	8
8.2 Types and contents of inspection documents	8
8.3 Specific inspection and testing	9
8.3.1 Extent of testing.....	9
8.3.2 Selection and preparation of samples and test pieces.....	9
8.3.3 Methods of test	9
9 Disputes	10
Annex A (informative) Additional information	17
A.1 Selection of stainless steels for use in precision strip form for spring applications.....	17
A.2 Further details on ferritic steel X6Cr17 (1.4016).....	17
A.3 Further details on martensitic steels	18
A.4 Further details on precipitation hardening steel X7CrNiAl17-7 (1.4568).....	18
A.5 Further details on austenitic steels.....	18
A.6 Further general guidelines on processing.....	18
A.6.1 Physical properties.....	18
A.6.2 Cleaning and heat treatment.....	18
A.6.3 Mean surface roughness.....	19

Foreword

This document (EN 10151:2002) has been prepared by Technical Committee ECISS/TC 23 "Steels for heat treatment, alloy steels and free-cutting steels - Qualities and dimensions", the secretariat of which is held by DIN.

This European Standard shall be given the status of a national standard, either by publication of an identical text or by endorsement, at the latest by May 2003, and conflicting national standards shall be withdrawn at the latest by May 2003.

Annex A is informative.

According to the CEN/CENELEC Internal Regulations, the national standards organizations of the following countries are bound to implement this European Standard: Austria, Belgium, Czech Republic, Denmark, Finland, France, Germany, Greece, Iceland, Ireland, Italy, Luxembourg, Malta, Netherlands, Norway, Portugal, Spain, Sweden, Switzerland and the United Kingdom.

1 Scope

1.1 This European Standard applies to cold rolled narrow strip of thicknesses up to and including 3 mm in rolled widths less than 600 mm made from the stainless steel grades listed in Table 1. The steels are used in the conditions given in Table 4 for the production of springs and spring parts that are exposed to corrosive effects and sometimes slightly increased temperatures.

1.2 Other steel grades than those listed in Table 1, but covered by prEN 10088-2 can be supplied in the above conditions after agreement between supplier and customer (see also annex A).

1.3 The general technical delivery conditions specified in EN 10021 apply in addition to the specifications of this European Standard, unless otherwise specified in this European Standard.

2 Normative references

This European Standard incorporates by dated or undated reference, provisions from other publications. These normative references are cited at the appropriate places in the text, and the publications are listed hereafter. For dated references, subsequent amendments to or revisions of any of these publications apply to this European Standard only when incorporated in it by amendment or revision. For undated references the latest edition of the publication referred to applies (including amendments).

CR 10260, *Designation systems for steels - Additional symbols.*

CR 10261, *Iron and steel - Review of available methods of chemical analysis.*

EN 10002-1, *Metallic materials - Tensile testing - Part 1: Method of test at ambient temperature.*

EN 10021, *General technical delivery requirements for steel and iron products.*

EN 10027-1, *Designation systems for steel - Part 1: Steel names, principal symbols.*

EN 10027-2, *Designation systems for steel - Part 2: Numerical system.*

EN 10052, *Vocabulary of heat treatment terms for ferrous products.*

EN 10079, *Definition of steel products.*

prEN 10088-2, *Stainless steels - Part 2: Technical delivery conditions for sheet/plate and strip of corrosion resisting steels for general and construction purposes.*

prEN 10168, *Iron and steel products – Inspection documents – List of information and description.*

EN 10204, *Metallic products - Types of inspection documents.*

EN 10258, *Cold-rolled stainless steel narrow strip and cut lengths - Tolerances on dimensions and shape.*

EN ISO 377, *Steel and steel products - Location and preparation of samples and test pieces for mechanical testing (ISO 377:1997).*

EN ISO 6507-1, *Metallic materials – Vickers hardness test – Part 1: Test method (ISO 6507-1:1997).*

EN ISO 7438, *Metallic materials – Bend test (ISO 7438:1985).*

ISO 14284, *Steel and iron - Sampling and preparation of samples for the determination of chemical composition.*

3 Terms and definitions

For the purposes of this European Standard, the following term and definition in addition to the terms and definitions given in EN 10021, EN 10052, EN 10079, prEN 10088-2, EN ISO 377 and ISO 14284 applies.

3.1

spool

strip spirally wound onto a supporting centre. Strip on a spool can also be welded together end-to-end

4 Classification and designation

4.1 Classification

Steels covered in this European Standard are classified according to their structure into:

- ferritic steels;
- martensitic steels;
- precipitation hardening steels;
- austenitic steels.

4.2 Designation

4.2.1 Steel names

For the steel grades covered by this European Standard, the steel names as given in the relevant tables are allocated in accordance with EN 10027-1 and CR 10260.

4.2.2 Steel numbers

For the steel grades covered by this European Standard, the steel numbers as given in the relevant tables are allocated in accordance with EN 10027-2 and CR 10260.

5 Information to be supplied by the purchaser

5.1 Mandatory information

The following information shall be supplied by the purchaser at the time of enquiry and order:

- a) the quantity to be delivered;
- b) the designation of the product form (e.g. strip or cut length);
- c) the number of the dimensional standard (EN 10258);
- d) the dimensions and tolerances on thickness, width and length according to EN 10258 and, if applicable, letters denoting relevant special tolerances (see 7.5);
- e) the internal coil diameter according to EN 10258 (see 7.5);
- f) the number of this European Standard (EN 10151);
- g) steel name or steel number (see 4.2);

EN 10151:2002 (E)

- h) the delivery condition (see 6.2.2),
- i) the type of inspection document in accordance with EN 10204 (see 8.2).

EXAMPLE

5 tons narrow strip according to EN 10258 of nominal thickness 0,80 mm ordered with precision thickness tolerances (P), nominal width of 250 mm with precision tolerances on width (P) in steel X5CrNi18-10 (1.4301) in the cold worked condition +C850, process route 2H, as specified in this European Standard and an inspection certificate 3.1.B according to EN 10204.

5 t narrow strip EN 10258-0,80Px250P
Steel EN 10151-X5CrNi18-10+C850+2H
EN 10204-3.1.B

or

5 t narrow strip EN 10258-0,80Px250P
Steel EN 10151-1.4301+C850+2H
EN 10204-3.1.B

5.2 Options

A number of options are specified in this European Standard and listed below. If the purchaser does not indicate his wish to implement one of these options, the supplier shall supply in accordance with the basis specification of this European Standard (see 5.1):

- a) any requirement concerning manufacturing process of the steel and of the products (see 6.1);
- b) any requirement concerning form of delivery (see 6.2.1.1);
- c) any requirement concerning condition of the edges (see 6.2.1.2);
- d) any requirement concerning special treatment conditions (see 6.2.2.1 and Table A.4);
- e) any requirement concerning special technological properties (see 7.3.1, Table 5 and 7.3.3);
- f) any requirement concerning surface finish (see 7.3.2);
- g) any requirement concerning bending limit of strip differing from Table 5 (see 7.3.1 and 8.3.3.2.2);
- h) any requirement concerning testing of internal soundness (see 7.4);
- i) any requirement concerning additional specific testing (see 8.1);
- j) any requirement concerning tensile testing for checking the uniformity of tensile strength (see 8.3.1 and Table 6);
- k) any requirement concerning determination of product analysis (see 8.3.2.2 and Table 6);
- l) any requirement concerning carrying out of bending ability tests (see 8.3.2.3 and Table 6);
- m) any requirement concerning tolerances on flatness, edge waviness and edge camber (see 8.3.3.3);
- n) any requirement concerning measurement of coil set including the relevant values (see 8.3.3.3).

6 Manufacturing process

6.1 General

Unless otherwise agreed at the time of enquiry and order, the steelmaking process and manufacturing process of the products are left to the discretion of the manufacturer.

6.2 Delivery

6.2.1 Delivery form

6.2.1.1 Strip is usually supplied in coils. Thin strip may be wound on a supporting centre, made of steel, cardboard or other material, in order to avoid the collapse of the centre. Strip may also be supplied as a spool (see 3.1), in order to increase coil weight, whilst minimising coil outside diameter. In the latter case, any welds shall be clearly marked.

Alternatively, strip may be supplied in cut lengths. These may be in a box, or on a pallet, and perhaps strapped together in bundles.

Several coils, or bundles of cut lengths, may be assembled on a carrier.

Unless otherwise agreed at the time of enquiry and order, the choice of delivery form is left to the discretion of the manufacturer.

6.2.1.2 Unless otherwise agreed at the time of enquiry and order, cold-rolled strip for springs is delivered with slit edges. By special agreement, strip can also be supplied with mill edges or with special edges, e.g. machined edges, deburred edges or edges dressed to produce a regular form, usually square or round.

6.2.2 Delivery condition

6.2.2.1 The condition in which the strip is to be delivered shall always be specified by the purchaser.

The delivery conditions possible are those given in Table 3 and Table 4.

In special cases, products may, if this is agreed, also be delivered in the treatment conditions given in Table A.4 which are normally reserved for finished springs.

6.2.2.2 In the condition +C, strip shall be delivered with a bright surface (2H), or a rough, matt surface (see 7.3.2).

Strip of steel types X20Cr13 (1.4021), X30Cr13 (1.4028), X39Cr13 (1.4031) and X7CrNiAl17-7 (1.4568) in the conditions "annealed" or "solution annealed" may be delivered, at the manufacturer's choice, with a bright annealed (2R), pickled (2D), pickled and skin passed (2B) or matt (2F) surface according to prEN 10088-2.

7 Requirements

7.1 Chemical composition

7.1.1 The chemical composition requirements given in Table 1 apply in respect of the chemical composition according to the cast analysis.

7.1.2 The product analysis may deviate from the limiting values for the cast analysis given in Table 1 by the values listed in Table 2.

7.2 Mechanical properties

7.2.1 For the tensile strength of spring-hard rolled strip, the data in Table 3 and Table 4 apply.

7.2.2 Regardless of the mass of the coil and for spools (see 3.1) of mass 500 kg or less, the maximum difference in tensile strength between the two ends of a coil or spool shall be 100 MPa (see 8.3.1). For spools with masses above 500 kg, the maximum difference in tensile strength shall be agreed at the time of enquiry and order.

7.3 Technological properties and surface condition

7.3.1 The strip shall have adequate bending ability. Unless otherwise agreed, the guidance data given in Table 5 apply. Cracks visible with the naked eye are not permitted.

7.3.2 The surface of the strip shall be one of those mentioned in 6.2.2 and defined in prEN 10088-2. Oil films from cold-rolling are permitted. Pits, grooves, scars and scratches are only permitted to the extent that they do not impair the performance of the spring. See also A.6.3.

7.3.3 If, for strip which is intended for high-duty springs, the requirements according to 7.3.1 and 7.3.2 are not sufficient, particular agreements shall be made at the time of enquiry and order.

7.4 Internal soundness

The products shall be free from internal defects that could impair their application to a significant extent. Tests appropriate for an assessment of the internal characteristics may be agreed upon at the time of enquiry and order.

7.5 Dimensions and tolerances on dimensions

The tolerances on thickness, width and length shall be specified in accordance with EN 10258.

The internal coil diameter shall be agreed in accordance with EN 10258.

8 Inspection and testing

8.1 General

The manufacturer shall carry out appropriate process control, inspection and testing to assure himself that the delivery complies with the requirements of the order.

This includes the following:

- a suitable frequency of verification of the dimensions of the products;
- an adequate intensity of visual examination of the surface quality of the products;
- an appropriate frequency and type of test to ensure that the correct grade of steel is used.

The nature and frequency of these verifications, examinations and tests are determined by the manufacturer, in the light of the degree of consistency that has been determined by the evidence of the quality system. In view of this, verifications by specific tests for these requirements are not necessary unless otherwise agreed.

8.2 Types and contents of inspection documents

8.2.1 At the time of enquiry and order, the issue of one of the inspection documents in accordance with EN 10204 shall be agreed for each delivery.

8.2.2 If the issuing of an inspection certificate 3.1.A, 3.1.B or 3.1.C according to EN 10204 or of an inspection report 3.2 according to EN 10204 has been agreed, specific inspections according to 8.3 are to be carried out and the following information shall be given in the inspection document with the code numbers and details required by prEN 10168:

- a) the information groups A, B and Z of prEN 10168;

- b) the results of the cast analysis in accordance with the code numbers C71 to C92 in prEN 10168;
- c) the results of the mandatory tests marked in the second column of Table 6 by an 'm';
- d) the result of any optional test or inspections agreed at the time of enquiry and order.

8.3 Specific inspection and testing

8.3.1 Extent of testing

The data in Table 6 apply for the composition of test units and for the number of tests per test unit, subject to the following exception for tensile strength:

If proof of uniformity of tensile strength (in accordance with 7.2.2) is agreed upon at the time of enquiry and order, a test piece shall be taken from both ends of each coil or spool (see 3.1). If, from one coil of hot-rolled or cold rolled material, several coils or spools of cold-rolled strip are produced and if these are numbered in sequence, it is only necessary to take a test piece from the beginning of each consecutively produced coil or spool.

8.3.2 Selection and preparation of samples and test pieces

8.3.2.1 General

The general conditions given in ISO 14284 and EN ISO 377 for the selection and preparation of samples and test pieces shall apply.

8.3.2.2 Product analysis

For product analysis, the selection and preparation of samples shall be carried out in conformity with the requirements of ISO 14284.

8.3.2.3 Tensile and bending tests

The test pieces for the tensile test and the bending test shall be taken in accordance with Figure 2 and prepared in accordance with EN 10002-1 and 8.3.3.2.2 respectively.

8.3.3 Methods of test

8.3.3.1 Chemical analysis

In cases of dispute, the reference method used for chemical analysis shall be in accordance with one of the European Standards listed in CR 10261.

8.3.3.2 Tensile and bending tests

8.3.3.2.1 The tensile test shall be carried out in accordance with EN 10002-1.

8.3.3.2.2 By analogy with the process of spring manufacture, to check the bending ability, a test strip, if possible 20 mm in width, is bent through 90° under a press around a mandrel with a radius matched to the thickness of the test piece (see Table 5). Bending is carried out perpendicularly to the longitudinal axis of the test piece, i.e. transverse to the direction of rolling in the case of longitudinal test pieces and parallel to the direction of rolling in the case of transverse test pieces.

In addition, the general specifications in EN ISO 7438 apply.

8.3.3.3 Tolerances on shape

The methods of testing flatness, edge waviness and edge camber and their tolerances may be agreed at the time of enquiry and order.

The measurement of coil set may be agreed at the time of enquiry and order. If agreed, the relevant values for the coil set, measured as the deflection a (see Figure 1), shall also be specified at the time of enquiry and order.

9 Disputes

The conditions for dealing with complaints laid down in EN 10021 shall apply.

Dimensions in millimetres

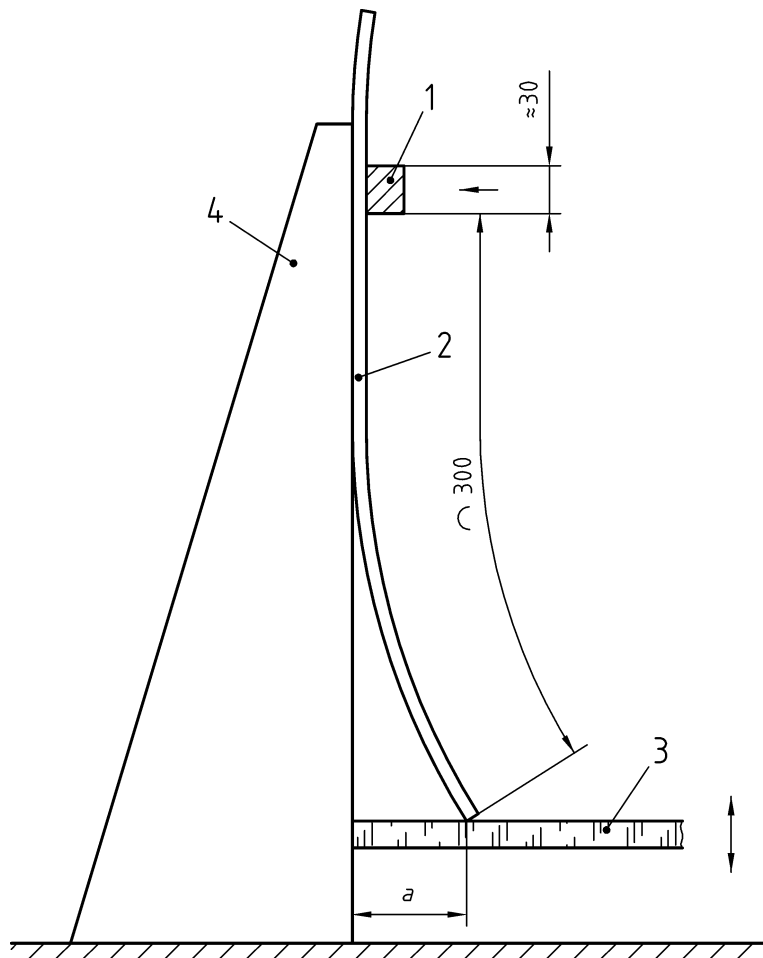

Key

- 1 Holder
- 2 Strip
- 3 Scale
- 4 Stand

Figure 1 — Coil set, measured as the deflection a , for a test length of 300 mm

Dimensions in millimetres

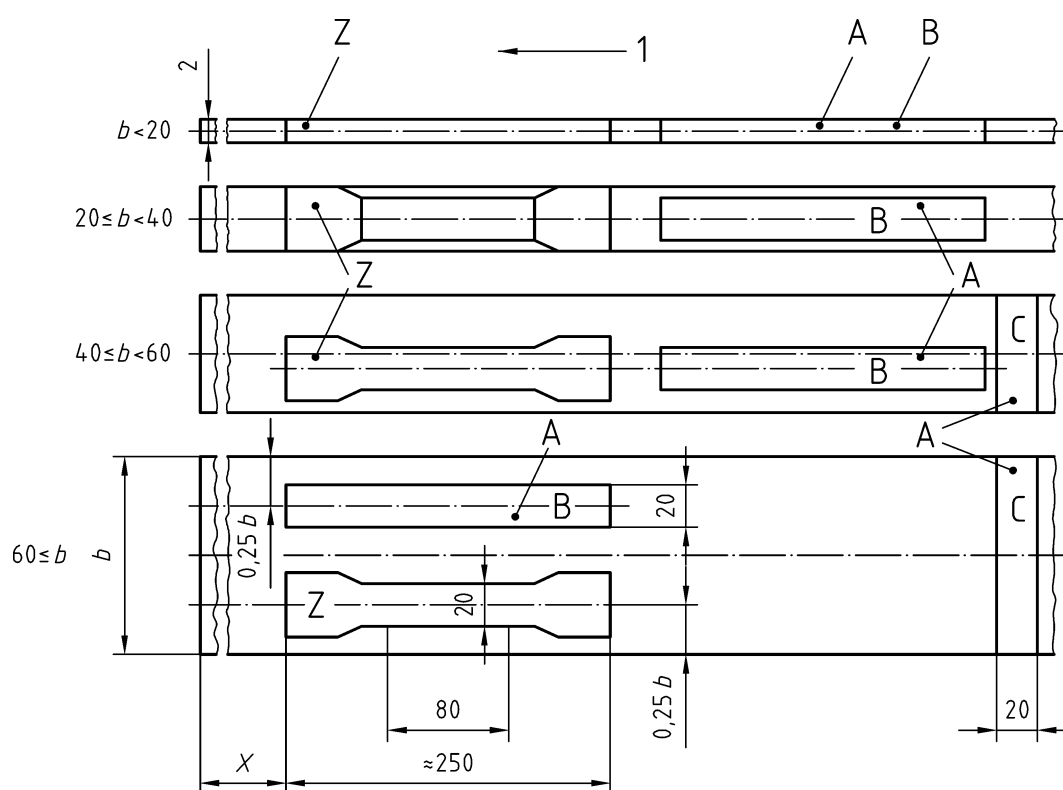

Key

- A Bending test piece, as far as possible with a width of 20 mm
- B Longitudinal test piece for bending transverse to rolling direction
- C Transverse test piece for bending parallel to rolling direction
- X In cases of dispute, the samples shall be taken at a distance of at least one lap from the inner or outer end of the coil
- Z Tensile test piece, a test piece having a gauge length of $L_o = 80$ mm and a width of 20 mm, or $L_o = 50$ mm and a width of 12,5 mm as specified in EN 10002-1. Also, for $b > 200$ mm, transverse test pieces may be used
- 1 Rolling direction
- 2 Outer strip edge
- b Strip width

Figure 2 — Test pieces

Table 1 — Chemical composition (cast analysis)^a of the steels

Steel designation		% by mass									
Name	Number	C	Si	Mn	P max.	S max.	N	Cr	Mo	Ni	Others
Ferritic steel											
X6Cr17	1.4016	max. 0,08	max. 1,00	max. 1,00	0,040	0,015		16,0 to 18,0			
Martensitic steels											
X20Cr13	1.4021	0,16 to 0,25	max. 1,00	max. 1,50	0,040	0,015		12,0 to 14,0			
X30Cr13	1.4028	0,26 to 0,35	max. 1,00	max. 1,50	0,040	0,015		12,0 to 14,0			
X39Cr13	1.4031	0,36 to 0,42	max. 1,00	max. 1,00	0,040	0,015		12,5 to 14,5			
Precipitation hardening steel											
X7CrNiAl17-7	1.4568	max. 0,09	max. 0,70	max. 1,00	0,040	0,015		16,0 to 18,0		6,5 to 7,8	Al:0,70 to 1,50
Austenitic steels											
X10CrNi18-8	1.4310	0,05 to 0,15	max. 2,00	max. 2,00	0,045	0,015	max. 0,11	16,0 to 19,0	max. 0,80	6,0 to 9,5	
X5CrNi18-10	1.4301	max. 0,07	max. 1,00	max. 2,00	0,045	0,015	max. 0,11	17,5 to 19,5		8,0 to 10,5	
X5CrNiMo17-12-2	1.4401	max. 0,07 ^b	max. 1,00	max. 2,00	0,045	0,015	max. 0,11	16,5 to 18,5	2,00 to 2,50 ^b	10,0 to 13,0 ^b	
X11CrNiMn19-8-6	1.4369	0,07 to 0,15	0,50 to 1,00	5,0 to 7,5	0,030	0,015	0,20 to 0,30	17,5 to 19,5		6,5 to 8,5	
X12CrMnNiN17-7-5	1.4372	max. 0,15	max. 1,00	5,5 to 7,5	0,045	0,015	0,05 to 0,25	16,0 to 18,0		3,5 to 5,5	

^a Elements not listed in this table shall not be intentionally added to the steel without the agreement of the purchaser except for finishing the cast. All appropriate precautions shall be taken to avoid the addition of such elements from scrap and other materials used in production which would impair mechanical properties and the suitability of the steel.

^b Where the corrosion resistance is of particular importance, one can also agree the delivery of steel grade X3CrNiMo17-13-3 (1.4436) of prEN 10088-2 with the specifications of this European Standard applicable for steel grade X5CrNiMo17-12-2 (1.4401).

Table 2 — Permissible product analysis tolerances on the limiting values given in Table 1 for the cast analysis

Element	Specified limits, cast analysis		Permissible tolerance ^a % by mass
	% by mass		
Carbon	> 0,030 > 0,20	≤ 0,030 ≤ 0,20 ≤ 0,42	+ 0,005 ± 0,01 ± 0,02
Silicon	> 1,00	≤ 1,00 ≤ 2,00	+ 0,05 + 0,10
Manganese	> 1,00 > 2,00	≤ 1,00 ≤ 2,00 ≤ 7,5	+ 0,03 + 0,04 ± 0,10
Phosphorus		≤ 0,045	+ 0,005
Sulfur		≤ 0,015	+ 0,003
Nitrogen	≥ 0,05	≤ 0,30	± 0,01
Aluminium		≤ 1,50	± 0,10
Chromium	≥ 12,0 ≥ 15,0	≤ 15,0 ≤ 19,5	± 0,15 ± 0,20
Molybdenum	≥ 1,75	< 1,75 ≤ 2,50	+ 0,05 ± 0,10
Nickel	> 5,0 > 10,0	≤ 5,0 ≤ 10,0 ≤ 13,0	- 0,07 ± 0,10 ± 0,15

^a If several product analyses are carried out on one cast, and the contents of an individual element determined lies outside the permissible range of the chemical composition specified for the cast analysis, then it is only allowed to exceed the permissible maximum value or to fall short of the permissible minimum value, but not both for one cast.

Table 3 — Tensile strength levels in the cold worked condition

Designation	Tensile strength ^{a,b} MPa ¹⁾
+C700	700 to 850
+C850	850 to 1 000
+C1000	1 000 to 1 150
+C1150	1 150 to 1 300
+C1300	1 300 to 1 500
+C1500	1 500 to 1 700
+C1700	1 700 to 1 900
+C1900	1 900 to 2 200
<p>^a Intermediate tensile strength values may be agreed. Alternatively, the steels may be specified in terms of minimum 0,2% proof strength or hardness, but only one parameter can be specified in one order (see Tables A.3 and A.6).</p> <p>^b The maximum available thickness for each tensile strength level and the remaining elongation decrease with the increase in tensile strength. Both are depending on the work hardening behaviour of the steel and the cold working conditions. Consequently, more exact information may be requested from the manufacturer.</p> <p>¹⁾ 1MPa = 1 N/mm²</p>	

Table 4 — Availability of steel grades in the cold worked condition

Steel designation		Available tensile strength levels							
Name	Number	+C700	+C850	+C1000	+C1150	+C1300	+C1500	+C1700	+C1900
Ferritic steel									
X6Cr17	1.4016	x	x	-	-	-	-	-	-
Martensitic steels									
X20Cr13 ^a	1.4021 ^a	x	x	-	-	-	-	-	-
X30Cr13 ^a	1.4028 ^a	x	x	-	-	-	-	-	-
X39Cr13 ^a	1.4031 ^a	x	x	-	-	-	-	-	-
Precipitation hardening steel									
X7CrNiAl17-7 ^b	1.4568 ^b	-	-	x	x	x	x	x	-
Austenitic steels									
X10CrNi18-8	1.4310	-	x	x	x	x	x	x	x
X5CrNi18-10	1.4301	x	x	x	x	x	-	-	-
X5CrNiMo17-12-2	1.4401	x	x	x	x	x	-	-	-
X11CrNiMnN19-8-6	1.4369	-	x	x	x	x	x ^c	-	-
X12CrMnNiN17-7-5	1.4372	-	x	x	x	x	x	-	-
<p>^a Also available in the annealed condition, with tensile strength ranges, R_m, as follows: X20Cr13: 500 MPa to 700 MPa; X30Cr13: 540 MPa to 740 MPa; X39Cr13: 560 MPa to 760 MPa and in the quenched and tempered condition (see Figures A.4 to A.6 and Table A.6).</p> <p>^b Also available in the solution annealed condition with the tensile strength range (R_m) of 800 MPa to 1000 MPa.</p> <p>^c Strip with tensile strength up to +C1500 can be supplied depending on requested thickness.</p>									

Table 5 — Data for the bending ability^{a,b} of strip

Steel designation		Delivery condition	Bending ability for a strip, thickness in millimetres							
Name	Number		> 0,05 to 0,25		above 0,25 to 0,50		above 0,50 to 0,75		above 0,75 to 1,00 ^c	
			For a direction of the axis of bend							
			transverse		longitudinal ^d		transverse		longitudinal ^d	
			Precipitation hardening steel							
X7CrNiAl17-7	1.4568	+C1150 +C1300 +C1500 +C1700	≤ 0,5	≤ 3,0	≤ 2,0	≤ 5,0	≤ 3,0	≤ 6,5	≤ 4,0	≤ 9,0
			≤ 2,0	≤ 5,0	≤ 3,0	≤ 9,0	≤ 4,0	≤ 10,0	≤ 6,0	≤ 11,0
			≤ 3,0	≤ 10,0	≤ 4,0	≤ 14,0	≤ 6,0	≤ 16,0	≤ 9,0	≤ 18,0
			≤ 6,0	≤ 18,0	≤ 7,0	≤ 19,0	≤ 9,0	≤ 20,0	≤ 11,0	≤ 21,0
			Austenitic steels							
X5CrNi18-10	1.4301	+C700 +C850 +C1000 +C1150 +C1300	≤ 0,5	≤ 1,0	≤ 0,5	≤ 2,0	≤ 1,0	≤ 3,0	≤ 1,5	≤ 5,0
			≤ 0,5	≤ 2,0	≤ 1,0	≤ 3,0	≤ 1,5	≤ 5,0	≤ 2,5	≤ 7,0
			≤ 1,0	≤ 3,0	≤ 1,5	≤ 5,0	≤ 2,5	≤ 7,0	≤ 3,0	≤ 9,0
			≤ 2,0	≤ 5,0	≤ 2,5	≤ 7,0	≤ 3,0	≤ 9,0	≤ 4,5	≤ 11,0
X10CrNi18-8 and X12CrNiMn17-7-5	1.4310 1.4372	+C850 +C1000 +C1150 +C1300 +C1500 +C1700 ^e +C1900 ^e	≤ 0,5	≤ 1,0	≤ 0,5	≤ 1,5	≤ 0,5	≤ 2,5	≤ 1,0	≤ 3,0
			≤ 0,5	≤ 2,0	≤ 0,5	≤ 2,5	≤ 1,0	≤ 3,0	≤ 2,0	≤ 4,0
			≤ 0,5	≤ 2,5	≤ 1,0	≤ 3,0	≤ 2,0	≤ 4,0	≤ 2,5	≤ 5,0
			≤ 1,5	≤ 3,0	≤ 2,0	≤ 4,0	≤ 2,5	≤ 5,0	≤ 3,0	≤ 7,0
X5CrNiMo17-12-2	1.4401	+C700 +C850 +C1000 +C1150 +C1300	≤ 0,5	≤ 3,0	≤ 1,0	≤ 4,0	≤ 1,5	≤ 6,0	≤ 2,0	≤ 8,0
			≤ 1,0	≤ 4,0	≤ 1,5	≤ 6,0	≤ 2,5	≤ 8,0	≤ 3,0	≤ 11,0
			≤ 1,5	≤ 6,0	≤ 2,0	≤ 8,0	≤ 3,0	≤ 11,0	≤ 4,5	≤ 14,0
			≤ 2,5	≤ 8,0	≤ 3,0	≤ 11,0	≤ 4,5	≤ 14,0	-	-
X11CrNiMn19-8-6	1.4369	+C1150 +C1300 +C1500	≤ 0,5	≤ 3,0	≤ 2,0	≤ 5,0	≤ 3,0	≤ 6,5	≤ 4,0	≤ 9,0
			≤ 2,0	≤ 5,0	≤ 3,0	≤ 9,0	≤ 4,0	≤ 10,0	≤ 6,0	≤ 11,0
			≤ 3,0	≤ 10,0	≤ 4,0	≤ 14,0	≤ 6,0	≤ 16,0	≤ 9,0	≤ 18,0
			≤ 3,0	≤ 10,0	≤ 4,0	≤ 14,0	≤ 6,0	≤ 16,0	≤ 9,0	≤ 18,0

^a Bending ability r/t (r = mandrel radius, t = strip thickness) at an angle of 90°.

^b Specific data are not currently available for ferritic and martensitic steels and for grade X11CrNiMn19-8-6 in conditions +C850 and +C1000.

^c For greater strip thickness, no values can as yet be given.

^d At present, unless otherwise agreed, the value shall be regarded as guidance data until more experience is obtained.

^e The values for conditions +C1700 and +C1900 are valid for grade X10CrNi18-8 (1.4310) only.

Table 6 — Tests to be carried out, test units and extent of testing in specific testing

Quality requirement ^a	b	Test unit	Number of		
			products per test unit	samples per product	test pieces per sample
Product analysis ^c	o	Cast	^d	1	1
Tensile test without checking the uniformity of tensile strength	m	Cast and production batch ^e	1 per 10 coils or spools or part thereof	1	1
Tensile test for checking the uniformity of tensile strength	o	Cast and production batch ^e	^f	^f	^f
Bending ability	o	Cast and production batch ^e	To be agreed at the time of enquiry and order		
Coil set	o	Cast and production batch ^e	To be agreed at the time of enquiry and order		
<p>^a If other tests are required, for example for the determination of the modulus of elasticity, this shall be agreed at the time of enquiry and order.</p> <p>^b m = the test shall be carried out in each case; o = the test shall be carried out only if agreed at the time of enquiry and order.</p> <p>^c If no product analysis is ordered, the chemical composition according to the cast analysis shall be given by the manufacturer for the elements listed in Table 1.</p> <p>^d Unless otherwise agreed at the time of enquiry and order, one test piece shall be taken per cast.</p> <p>^e Same cast, same nominal thickness, same final heat treatment condition (i.e. same heat treatment and/or same degree of cold deformation).</p> <p>^f See 8.3.1.</p>					

Annex A (informative)

Additional information

A.1 Selection of stainless steels for use in precision strip form for spring applications

There are many different demands for the use of corrosion resistant steels in precision strip form for spring applications. Theoretically, any of the steels specified in prEN 10088-2 can be used. This standard details the properties of the more common steels used. Both delivery and use conditions for each component depends on the corrosive environment, strip size, mechanical properties required, the shape of the part, amount and method of forming, life of the part, cost constraints and any special physical properties required.

For spring applications, the steel is used in a "hard" or high strength condition. High strength is obtained in different ways for the different steel structures, and the final spring properties depend upon the specific process route and the steel chosen.

Austenitic, austenitic-ferritic and ferritic structure steels are not generally hardened by heat treatment. The higher strengths are obtained by cold rolling. The rate of cold work hardening depends upon the steel composition. After the same percentage cold reduction, a less stable austenitic grade such as X10CrNi18-8 (1.4310) will have a higher R_m and HV , and retain a higher A value than a more stable austenitic grade such as X5CrNi18-10 (1.4301). For more details see Tables A.2 and A.3. Ferritic steels cold work harden to a lesser extent than austenitic and austenitic-ferritic grades. Therefore, the properties obtainable in a specific steel at a specific thickness depends upon the degree of cold reduction and the work hardening characteristic. However, it is possible to increase R_m and E in the formed spring by tempering (see A.3 to A.5, Tables A.4 and A.5 and Figures A.1 to A.3).

Martensitic steels are more "springy" than austenitic or ferritic steels. They are less ductile and with lower corrosion resistance, the material costs are lower, but the heat treatment can be more expensive. The method of use of these steels is different. The steel producer usually supplies them to the springmaker in either the annealed or lightly cold rolled condition, and only rarely in the quenched and tempered condition. The lightly cold rolled condition is easier to blank. It is usually after formation of the spring that these steels are heat treated by quenching and tempering to obtain the desired balance of strength and ductility (For more details see A.3, Tables A.4 to A.6 and Figures A.4 to A.6).

The precipitation - hardening grade X7CrNiAl17-7 (1.4568) can be used in one of two ways, as follows:

- 1) delivered in the solution annealed condition. After spring formation, the springs are hardened by a double artificial ageing treatment (see A.4).
- 2) delivered after cold rolling to a strength level of C1300 or higher. After spring formation, a single artificial ageing treatment (see A.4, Table A.5 and Figure A.1) increases E and R_m .

For this steel, the hardening is achieved both by work hardening in cold rolling and by the precipitation of another phase from the matrix.

In Table A.1 some of the features of the use of different steel grades are listed.

A.2 Further details on ferritic steel X6Cr17 (1.4016)

This steel is only hardened by cold rolling. As an alternative to Table 4, the strength can be specified by HV as shown in Table A.3. The modulus of elasticity, E , has a value of approximately 210 MPa, which cannot be increased by heat treatment. Table A.2 shows that this steel has low ductility in the cold worked condition, so sharp radii cannot be used.

A.3 Further details on martensitic steels

Table A.6 shows the Vickers hardness levels available in martensitic steels, and Table A.4 shows the harden and temper conditions needed for the higher hardness levels. Although in some cases the steels may be delivered in the quenched and tempered condition (process route and surface condition code 2Q), the supply in the annealed condition is more common, for maximum formability, or in the lightly cold-rolled condition, when ease of stamping is more important than maximum formability. Then, after spring formation, the springs are often quenched and tempered, choosing a lower tempering temperature, such as 250 °C, if a harder, less ductile material is required, or a higher tempering temperature, such as 350 °C, if a softer, more ductile material is required (see also Figures A.4 to A.6). The harden and temper treatment also raises the modulus of elasticity, E , as shown in Table A.5.

A.4 Further details on precipitation hardening steel X7CrNiAl17-7 (1.4568)

Steel delivered in the solution annealed condition (+AT) will typically have been annealed at 1030 °C to 1 050 °C and air cooled to give R_m of 800 MPa to 1 000 MPa.

After spring formation, double artificial ageing treatment is carried out by one of the two methods shown in Table A.4.

The condition of supply that produces the hardest final material is to cold roll the steel to a strength of +C1300 or higher. Then, after spring formation, a single artificial ageing treatment is carried out as shown in Table A.4. This treatment increases R_m and E . The effect on R_m is shown in Figure A.1 and the effect on E is shown in Table A.5.

Where greater formability is required, the possibility of supply in the solution annealed condition or a less cold worked condition should be considered, and it is recommended that this be discussed with the steelmaker.

A.5 Further details on austenitic steels

These steels are hardened principally by work hardening. As an alternative to specification in terms of R_m , a Vickers Hardness range can be specified, as shown in Table A.3. In choosing the specification, note should be taken of the remaining ductility in the steels, as shown in Table A.2.

After spring formation, strength can be further increased by a tempering treatment, as shown in Table A.4.

The effect on the modulus of elasticity, E , is given in Table A.5. The effect on R_m is shown in Figures A.1 to A.3. This final tempering treatment also removes the processing stresses introduced during spring formation, and is recommended for this reason, as well as because of the strength increase.

A.6 Further general guidelines on processing

A.6.1 Physical properties

In A.1 to A.5 and Tables A.1 and A.5 the variations in the values of E are described. It should be noted that the values of E decrease with increasing temperature. The variation of magnetic properties with chemical composition and treatment are described in Table A.1.

A.6.2 Cleaning and heat treatment

The springs should be thoroughly cleaned before heat treatment. If the colours produced by heat treatment are not permissible for visual or corrosion-resistance reasons, the heat treatment can be carried out in a protective atmosphere, or a suitable cleaning process can be used which does not impair the spring properties.

A.6.3 Mean surface roughness

The surface condition of strip is characterised by the following approximate values for the mean surface roughness:

- $R_a < 0,3 \mu\text{m}$ for tensile levels of +C1150 and higher.
- $R_a < 0,5 \mu\text{m}$ for tensile levels of +C700 to +C1000.

Table A.1 — Some features of the use of different steel grades

Steel designation		Features of using these steels
Steel name	Steel number	
<u>Ferritic steel (see A.2)</u>		
X6Cr17	1.4016	Hardenable only by cold rolling, and only to a moderate level (see Tables 4, A.2 and A.3). Moderate corrosion resistance. High magnetic permeability in all conditions.
<u>Martensitic steels (see A.3)</u>		
X20Cr13 X30Cr13 X39Cr13	1.4021 1.4028 1.4031	More 'springy' than austenitic or ferritic steels. High strength obtained after spring formation by quench and temper heat treatment. Quench and temper treatment also increases E . Lower ductility and corrosion resistance than other stainless steel structures. Final strength increases with carbon content (see Table A.6). High magnetic permeability in all conditions.
<u>Precipitation-hardening steel (see A.4)</u>		
X7CrNiAl17-7	1.4568	High fatigue strength. Hardenable by heat treatment to very high strength level. Higher elevated temperature strength, but lower corrosion resistance than austenitic steels. Maximum temperature of use can be between 250 °C and 300 °C, depending on the stress. Some degree of magnetic permeability, depending on the condition.

(continued)

Table A.1 – (continued)

Steel designation		Features of using these steels
Steel name	Steel number	
<u>Austenitic steels (see A.5)</u>		
X10CrNi18-8	1.4310	The stainless steel most commonly used for springs and with the highest possible R_m . Relatively unstable austenitic structure. High R_m in solution annealed condition. Highest rate of work hardening gives high R_m , whilst still retaining some ductility (A%). Maximum temperature of use can be between 120 °C and 250 °C, depending upon the stress. Some degree of magnetic permeability, depending on condition. Corrosion resistance a little less than for 1.4301.
X5CrNi18-10	1.4301	Most common austenitic stainless steel. Relatively stable austenitic structure results in lower work hardening rate than 1.4372 or 1.4310. Maximum temperature of use can be between 120 °C and 250 °C, depending upon the stress. Some degree of magnetic permeability, depending on the condition, but less than X10CrNi18-8 (1.4310). Medium corrosion resistance within the austenitic range.
X12CrMnNiN17-7-5	1.4372	High R_p and R_m in solution annealed condition. Work-hardening rate > 1.4301 but < 1.4310. Magnetic permeability less than for 1.4301. Use of this grade a tradition from USA.
X4CrNi18-12	1.4303	Lower magnetic permeability than 1.4301. Used e.g. for TV parts.
X6CrNiTi18-10	1.4541	Especially used in aerospace and related applications.
X6CrNiNb18-10	1.4550	Similar corrosion resistance to 1.4301.
X5CrNiMo17-12-2	1.4401	Used where superior corrosion resistance to 1.4301 is required. Maximum temperature of use can be 120 °C to 250 °C, depending upon the stress.
X3CrNiMo17-13-3	1.4436	
X11CrNiMnN19-8-6	1.4369	Completely non-magnetic in all conditions. High R_m in solution annealed condition, and capable of being cold rolled to a very high R_m . Maximum temperature of use can be between 120 °C to 250 °C, depending upon the stress. Work-hardening rate > 1.4301 but < 1.4310. Corrosion resistance similar to 1.4310.
<u>Austenitic-ferritic steels</u>		
X2CrNiMoN22-5-3	1.4462	Chosen for seawater corrosion resistance. High R_m in the solution annealed condition. Lower work hardening rate than 1.4301.
X2CrNiMoN25-7-4	1.4410	

Table A.2 — Information on minimum elongation values ($A_{80}\%$) for cold-rolled ferritic and austenitic steels at different tensile strength levels

Steel designation		$A_{80}\%$, min. (longitudinal) for tensile strength level							
Name	Number	+C700	+C850	+C1000	+C1150	+C1300	+C1500	+C1700	+C1900
Ferritic steel									
X6Cr17	1.4016	2	1	-	-	-	-	-	-
Austenitic steels									
X10CrNi18-8	1.4310	35 ^a	25	20	15	10	5	2	1
X5CrNi18-10	1.4301	25	12	5	3	1	-	-	-
X5CrNiMo17-12-2	1.4401	20	10	4	1	-	-	-	-
X12CrMnNiN17-7-5	1.4372	40 ^a	25	13	5	2	1	-	-
X11CrNiMnN19-8-6	1.4369	35 ^a	12	9	8	2	1	-	-

^a Steel in the softened condition; not used for springs.

Table A.3 — Vickers hardness levels available in the cold rolled condition for ferritic and austenitic steels (see A.2 and A.5)

Steel designation		Total available HV range ^{a,b}	Tolerance on HV aim value
Name	Number		
Ferritic steel			
X6Cr17	1.4016	200 to 300	+/- 20HV
Austenitic steels			
X10CrNi18-8	1.4310	250 to 450 451 to 600	+/- 25HV +/- 30HV
X5CrNi18-10	1.4301	220 to 450	+/- 25HV
X5CrNiMo17-12-2	1.4401	220 to 400	+/- 25HV
X12CrMnNiN17-7-5	1.4372	250 to 450 451 to 500	+/- 25HV +/- 30HV
X11CrNiMnN19-8-6	1.4369	300 to 450 451 to 475	+/- 25HV +/- 30HV

^a Steels can be supplied to any HV aim value within the range.
^b HV shall be determined in accordance with EN ISO 6507-1.

Table A.4 — Guidance data for heat treatment of springs made of strip ^a

Steel designation		Heat treatment ^b					Increase in tensile strength
Name	Number	Initial condition	Temperature/Duration	Cooling	Temperature/Duration	Cooling	
Martensitic steels							
X20Cr13	1.4021	annealed	Hardening: max. 30 min 950 °C – 1050 °C	oil / air	Tempering: max. 1 h 200 °C – 400 °C		see Figure A.4
X30Cr13	1.4028		950 °C – 1050 °C	oil / air	200 °C – 400 °C		see Figure A.5
X39Cr13	1.4031		1000 °C – 1100 °C	oil / air	200 °C – 400 °C		see Figure A.6
Precipitation hardening steel							
X7CrNiAl17-7	1.4568	cold	Tempering ^c : 480 °C / 2h to 550 °C/1h	air			see Figure A.1
		rolled solution annealed	1st artificial ageing: 760 °C / 40 min to 820 °C / 30 min	water/air <12 °C ^d	2nd artificial ageing: 480 °C / 2 h to 550 °C / 1 h	air	300 MPa - 550 MPa ^e
Austenitic steels							
X10CrNi18-8	1.4310	cold rolled	Tempering: 250 °C / 24 h to 450 °C / 30 min	air			see Figure A.1
X5CrNi18-10	1.4301						see Figure A.2
X5CrNiMo17-12-2	1.4401						see Figure A.3
X12CrMnNiN17-7-5	1.4372						see Figure A.1
X11CrMnNiN19-8-6	1.4369						see Figure A.1
^a See the classification of the tensile strength data in Tables 3 and 4 and Figures A.1 to A.3. ^b The optimum heat treating conditions may vary. Heat treating conditions suiting the purpose shall be chosen. ^c The tempering of X7CrNiAl17-7 in cold rolled condition +C1300 and higher has some degree of artificial ageing. ^d The lower maximum temperature depends on the temperature and duration of the intermediate annealing. ^e A higher tensile strength of 1450 MPa can be achieved by heat treatment +P1450 (prEN 10088-2): Intermediate annealing at 945 °C to 965 °C / 10 min; air cooling; low temperature treatment at –70 °C / 8h and precipitation hardening at 500 °C to 520 °C / 1h. 1 MPa = 1 N/mm ² .							

Table A.5 — Guidance data for the moduli of elasticity^{a,b}

Steel designation		Modulus of elasticity in the	
Name	Number	Delivery Condition +C	Cold rolled and heat treated condition
GPa			
Ferritic steel			
X6Cr17	1.4016	210	-
Martensitic steels			
X20Cr13	1.4021	210	220 ^b
X30Cr13	1.4028	210	220 ^b
X39Cr13	1.4031	210	220 ^b
Precipitation hardening steel			
X7CrNiAl17-7	1.4568	195	200
Austenitic steels			
X10CrNi18-8	1.4310	185	195
X5CrNi18-10	1.4301	185	195
X5CrNiMo17-12-2	1.4401	180	190
X12CrMnNiN17-7-5	1.4372	200	210
X11CrNiMnN19-8-6	1.4369	190	200
^a The reference data for the modulus of elasticity are applicable to measurements on longitudinal tensile test pieces for a mean tensile strength of 1 800 MPa; for a mean tensile strength of 1 300 MPa, the values are 6 GPa lower. Intermediate values may be interpolated.			
^b Applies to condition +QT, see Tables A.4 and A.6, and Figures A.4 to A.6.			

Table A.6 — Vickers hardness levels available in martensitic steels

Steel designation		Vickers hardness levels (HV) in the supply condition (see A.3)		
Name	Number	Annealed	Lightly cold rolled	Quenched and tempered ^a
X20Cr13	1.4021	190 to 240	240 to 290	480 to 520
X30Cr13	1.4028	190 to 240	270 to 320	500 to 540
X39Cr13	1.4031	200 to 250	270 to 320	520 to 560
^a Hardness ranges typical when tempered at 300 °C. See A.3 and Figures A.4 to A.6 for more information.				

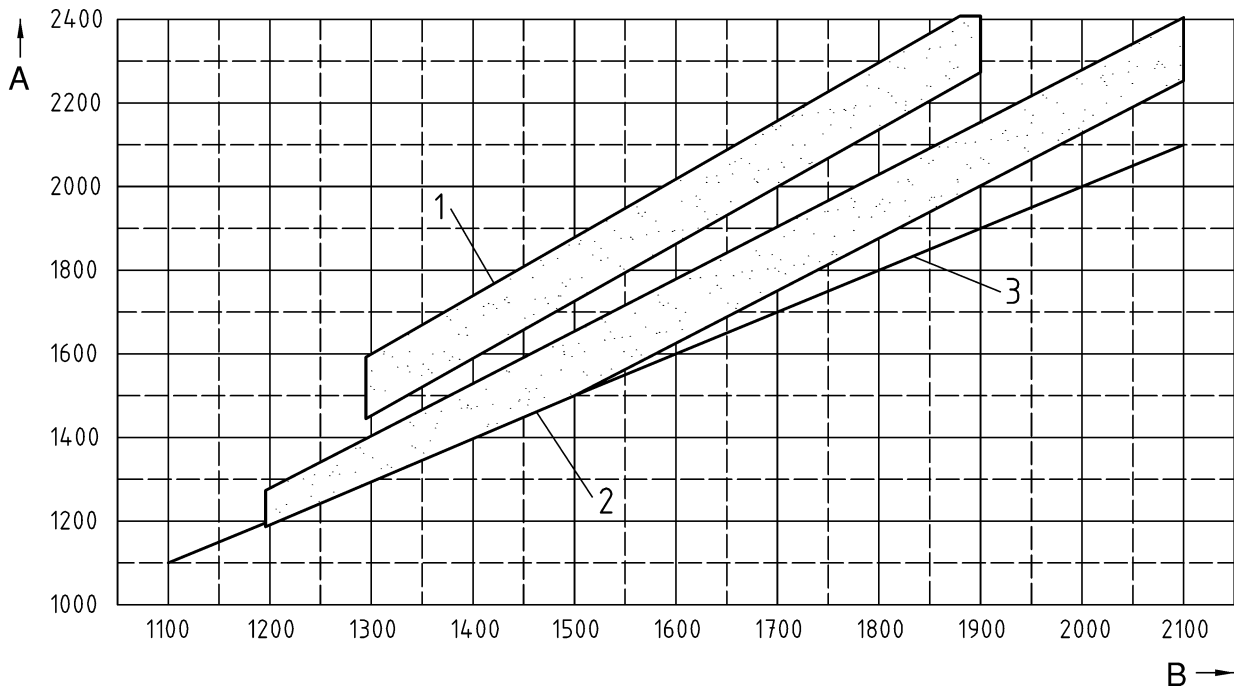

Key

- A Tensile strength after heat treatment in MPa*
- B Tensile strength of strip in initial state (cold-rolled) in MPa*
- 1 X7CrNiAl17-7 tempered^a
- 2 X10CrNi18-8 tempered, X12CrMnNiN17-7-5 tempered^b, X11CrNiMnN19-8-6 tempered^b
- 3 initial state (cold-rolled)

NOTE 1 The increase in tensile strength depends on the chemical analysis of the relevant steel grade.

NOTE 2 At lower tensile ranges, the increase in tensile strength is much lower than the increase in 0,2 % proof strength. Therefore, the increase of spring-properties of the heat treated material or parts is much higher than the tensile values indicate.

^a The tempering of X7CrNiAl17-7 in cold rolled conditions +C1300 and higher has some degree of artificial ageing.

^b For steel X12CrMnNiN17-7-5 and X11CrNiMnN19-8-6 the maximum tensile strength in initial state is 1 700 MPa *.

* 1 MPa = 1 N/mm²

Figure A.1 — Guidance data for the increase in tensile strength of cold-rolled strip made of steels X10CrNi18-8 (1.4310), X12CrMnNiN17-7-5 (1.4372), X11CrNiMnN19-8-6 (1.4369) and X7CrNiAl 17-7 (1.4568) by heat treatment (see Table A.4)

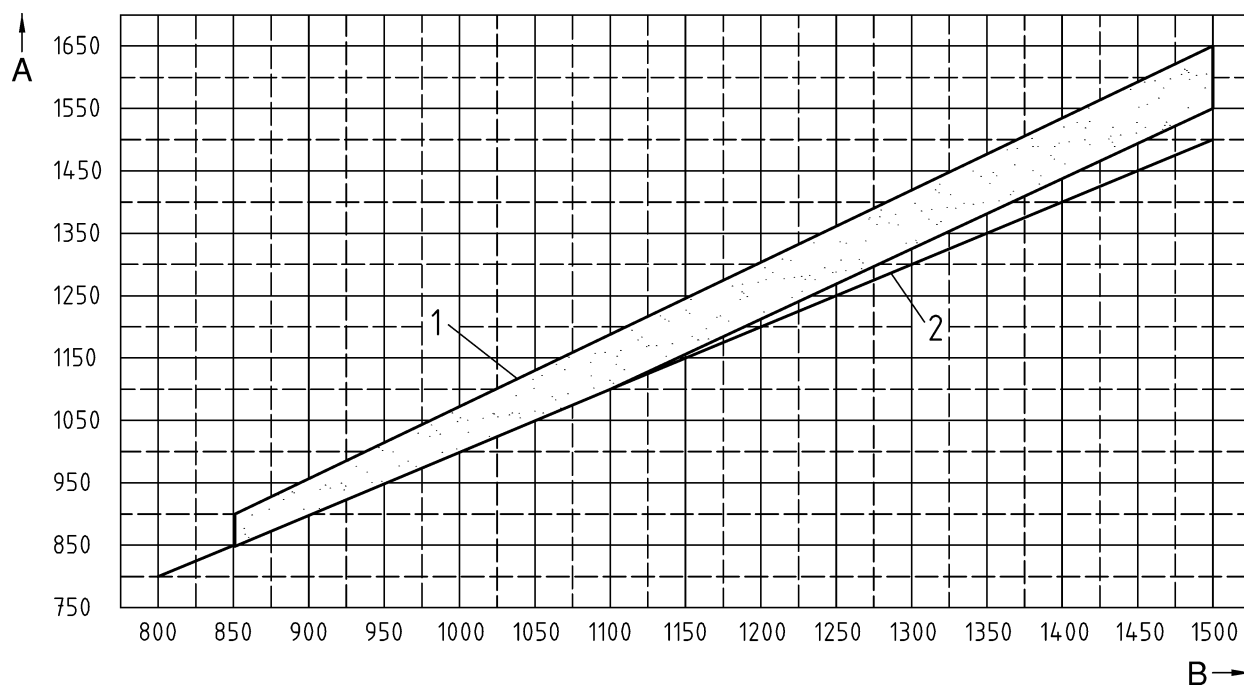

Key

- A Tensile strength after heat treatment in MPa*
- B Tensile strength of strip in initial state (cold-rolled) in MPa*
- 1 X5CrNi18-10 tempered
- 2 initial state (cold-rolled)

NOTE 1 The increase in tensile strength depends on the chemical analysis of the relevant steel grade.

NOTE 2 At lower tensile ranges, the increase in tensile strength is much lower than the increase in 0,2 % proof strength. Therefore, the increase of spring properties of the heat treated material or parts is much higher than the tensile values indicate.

* 1 MPa = 1 N/mm²

Figure A.2 — Guidance data for the increase in tensile strength of cold-rolled strip made of steel X5CrNi18-10 (1.4301) by heat treatment (see Table A.4)

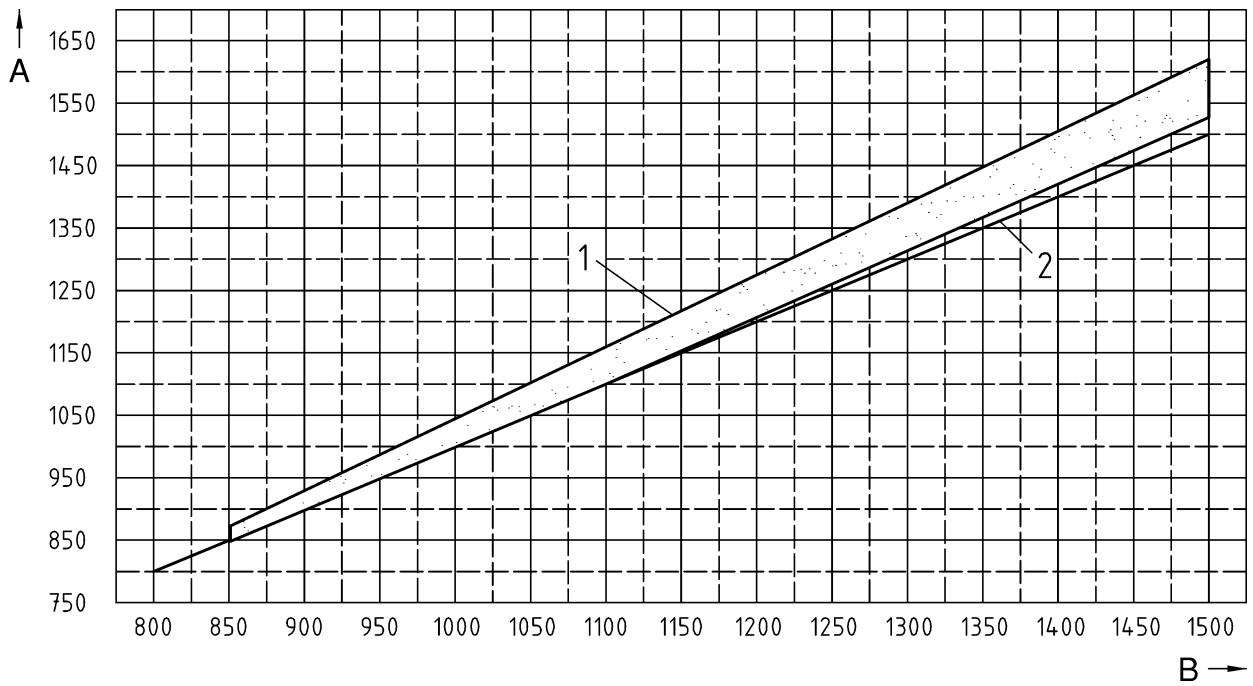

Key

- A Tensile strength after heat treatment in MPa*
- B Tensile strength of strip in initial state (cold-rolled) in MPa*
- 1 X5CrNiMo17-12-2 tempered
- 2 initial state (cold-rolled)

NOTE 1 The increase in tensile strength depends on the chemical analysis of the relevant steel grade.

NOTE 2 At lower tensile ranges, the increase in tensile strength is much lower than the increase in 0,2 % proof strength. Therefore, the increase of spring properties of the heat treated material or parts is much higher than the tensile values indicate.

* 1 MPa = 1 N/mm²

Figure A.3 — Guidance data for the increase in tensile strength of cold-rolled strip made of steel X5CrNiMo17-12-2 (1.4401) by heat treatment (see Table A.4)

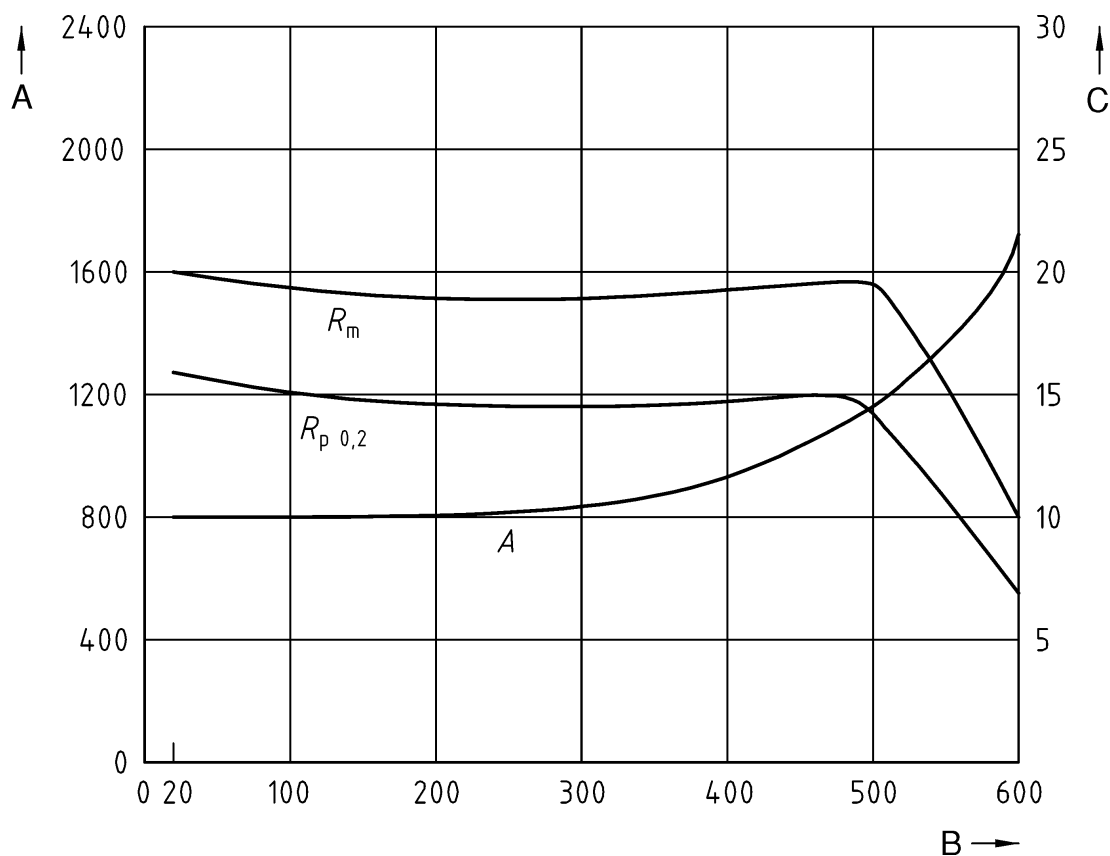
**Key**

A Tensile strength in MPa*

B Tempering temperature^a in °C

C Elongation in %

^a If the tempering temperature exceeds 400 °C, both the corrosion resistance and the hardness are significantly reduced.* 1 MPa = 1 N/mm²

Figure A.4 — Guidance data on the mechanical characteristics of steel X20Cr13 (1.4021) after quenching and tempering (see Table A.4)

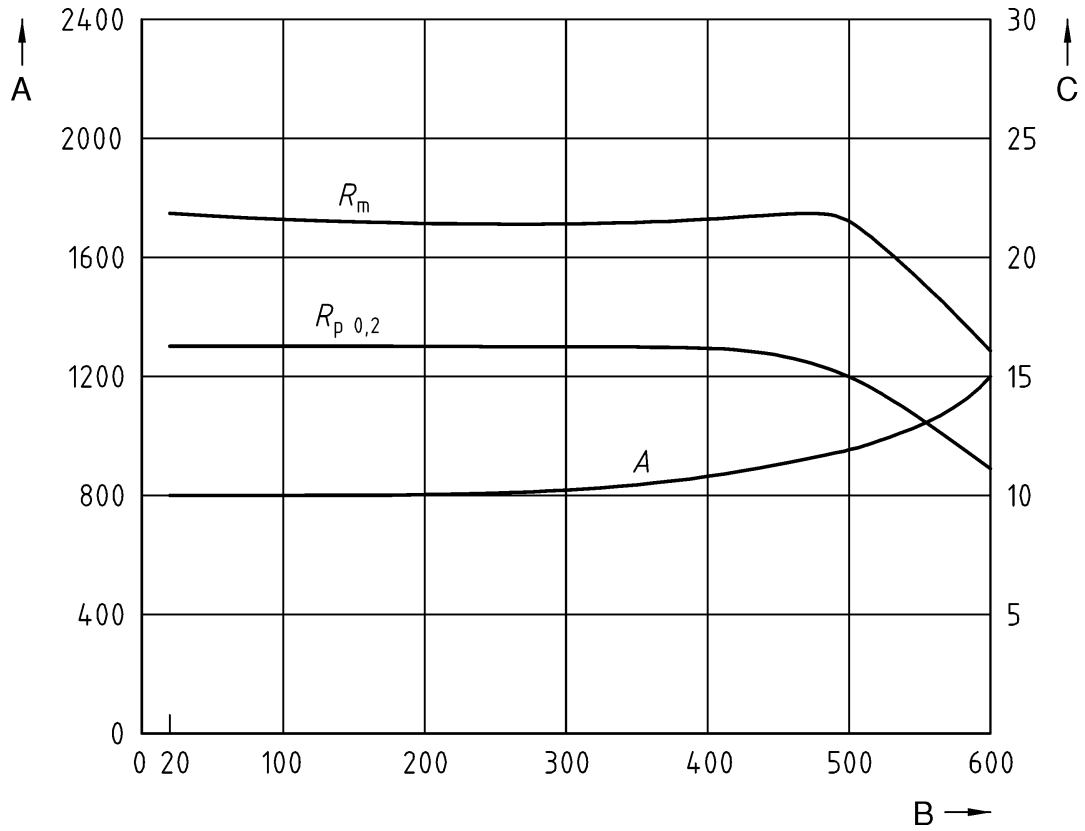

Key

- A Tensile strength in MPa*
- B Tempering temperature^a in °C
- C Elongation in %

^a If the tempering temperature exceeds 400°C, both the corrosion resistance and the hardness are significantly reduced.

* 1 MPa = 1 N/mm²

Figure A.5 — Guidance data on the mechanical characteristics of steel X30Cr13 (1.4028) after quenching and tempering (see Table A.4)

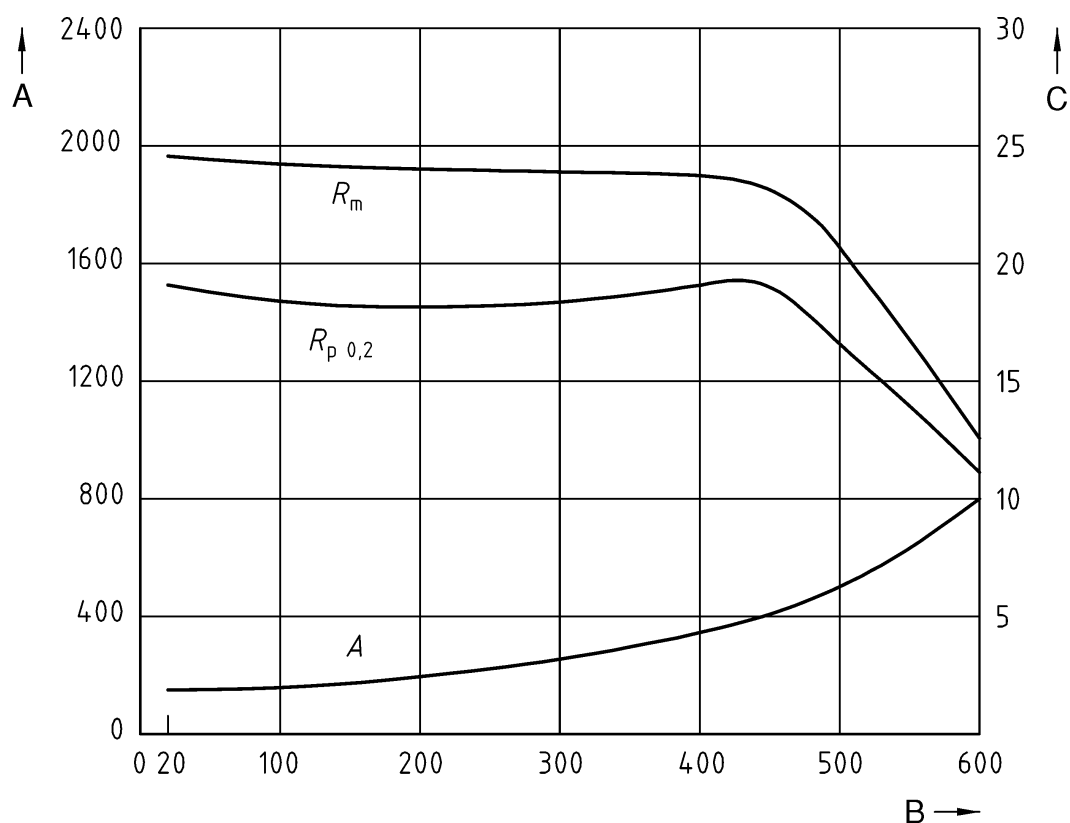

Key

- A Tensile strength in MPa*
 B Tempering temperature^a in °C
 C Elongation in %

^a If the tempering temperature exceeds 400°C, both the corrosion resistance and the hardness are significantly reduced.

* 1 MPa = 1 N/mm²

Figure A.6 — Guidance data on the mechanical characteristics of steel X39Cr13 (1.4031) after quenching and tempering (see Table A.4)

BSI — British Standards Institution

BSI is the independent national body responsible for preparing British Standards. It presents the UK view on standards in Europe and at the international level. It is incorporated by Royal Charter.

Revisions

British Standards are updated by amendment or revision. Users of British Standards should make sure that they possess the latest amendments or editions.

It is the constant aim of BSI to improve the quality of our products and services. We would be grateful if anyone finding an inaccuracy or ambiguity while using this British Standard would inform the Secretary of the technical committee responsible, the identity of which can be found on the inside front cover.
Tel: +44 (0)20 8996 9000. Fax: +44 (0)20 8996 7400.

BSI offers members an individual updating service called PLUS which ensures that subscribers automatically receive the latest editions of standards.

Buying standards

Orders for all BSI, international and foreign standards publications should be addressed to Customer Services. Tel: +44 (0)20 8996 9001.
Fax: +44 (0)20 8996 7001. Email: orders@bsi-global.com. Standards are also available from the BSI website at <http://www.bsi-global.com>.

In response to orders for international standards, it is BSI policy to supply the BSI implementation of those that have been published as British Standards, unless otherwise requested.

Information on standards

BSI provides a wide range of information on national, European and international standards through its Library and its Technical Help to Exporters Service. Various BSI electronic information services are also available which give details on all its products and services. Contact the Information Centre.
Tel: +44 (0)20 8996 7111. Fax: +44 (0)20 8996 7048. Email: info@bsi-global.com.

Subscribing members of BSI are kept up to date with standards developments and receive substantial discounts on the purchase price of standards. For details of these and other benefits contact Membership Administration.
Tel: +44 (0)20 8996 7002. Fax: +44 (0)20 8996 7001.
Email: membership@bsi-global.com.

Information regarding online access to British Standards via British Standards Online can be found at <http://www.bsi-global.com/bsonline>.

Further information about BSI is available on the BSI website at <http://www.bsi-global.com>.

Copyright

Copyright subsists in all BSI publications. BSI also holds the copyright, in the UK, of the publications of the international standardization bodies. Except as permitted under the Copyright, Designs and Patents Act 1988 no extract may be reproduced, stored in a retrieval system or transmitted in any form or by any means – electronic, photocopying, recording or otherwise – without prior written permission from BSI.

This does not preclude the free use, in the course of implementing the standard, of necessary details such as symbols, and size, type or grade designations. If these details are to be used for any other purpose than implementation then the prior written permission of BSI must be obtained.

Details and advice can be obtained from the Copyright & Licensing Manager.
Tel: +44 (0)20 8996 7070. Fax: +44 (0)20 8996 7553.
Email: copyright@bsi-global.com.