

Metallic materials — Tensile testing —

Part 1: Method of test at ambient temperature

The European Standard EN 10002-1:2001 has the status of a
British Standard

ICS 77.040.10

National foreword

This British Standard is the official English language version of EN 10002-1:2001. It supersedes BS EN 10002-1:1990 which is withdrawn.

The UK participation in its preparation was entrusted by Technical Committee ISE/NFE/4, Mechanical testing of metals, to Subcommittee ISE/NFE/4/1, Uniaxial testing of metals, which has the responsibility to:

- aid enquirers to understand the text;
- present to the responsible European committee any enquiries on the interpretation, or proposals for change, and keep the UK interests informed;
- monitor related international and European developments and promulgate them in the UK.

A list of organizations represented on this subcommittee can be obtained on request to its secretary.

Cross-references

The British Standards which implement international or European publications referred to in this document may be found in the BSI Standards Catalogue under the section entitled “International Standards Correspondence Index”, or by using the “Find” facility of the BSI Standards Electronic Catalogue.

A British Standard does not purport to include all the necessary provisions of a contract. Users of British Standards are responsible for their correct application.

Compliance with a British Standard does not of itself confer immunity from legal obligations.

This British Standard, having been prepared under the direction of the Engineering Sector Policy and Strategy Committee, was published under the authority of the Standards Policy and Strategy Committee on 6 September 2001

Summary of pages

This document comprises a front cover, an inside front cover, the EN title page, pages 2 to 56, an inside back cover and a back cover.

The BSI copyright date displayed in this document indicates when the document was last issued.

Amendments issued since publication

Amd. No.	Date	Comments

English version

Metallic materials - Tensile testing - Part 1: Method of test at ambient temperature

Matériaux métalliques - Essai de traction - Partie 1:
Méthode d'essai à température ambiante

Metallische Werkstoffe - Zugversuch - Teil 1: Prüfverfahren
bei Raumtemperatur

This European Standard was approved by CEN on 12 May 2001.

CEN members are bound to comply with the CEN/CENELEC Internal Regulations which stipulate the conditions for giving this European Standard the status of a national standard without any alteration. Up-to-date lists and bibliographical references concerning such national standards may be obtained on application to the Management Centre or to any CEN member.

This European Standard exists in three official versions (English, French, German). A version in any other language made by translation under the responsibility of a CEN member into its own language and notified to the Management Centre has the same status as the official versions.

CEN members are the national standards bodies of Austria, Belgium, Czech Republic, Denmark, Finland, France, Germany, Greece, Iceland, Ireland, Italy, Luxembourg, Netherlands, Norway, Portugal, Spain, Sweden, Switzerland and United Kingdom.



EUROPEAN COMMITTEE FOR STANDARDIZATION
COMITÉ EUROPÉEN DE NORMALISATION
EUROPÄISCHES KOMITEE FÜR NORMUNG

Management Centre: rue de Stassart, 36 B-1050 Brussels

Contents

	page
Foreword.....	4
1 Scope	5
2 Normative references	5
3 Principle	5
4 Definitions.....	5
5 Symbols and designations	8
6 Test piece.....	10
6.1 Shape and dimensions.....	10
6.2 Types.....	11
6.3 Preparation of test pieces	11
7 Determination of original cross-sectional area (S_0).....	11
8 Marking the original gauge length (L_0).....	12
9 Accuracy of testing apparatus	12
10 Conditions of testing	12
10.1 Method of gripping	12
10.2 Test rate	12
11 Determination of percentage elongation after fracture (A)	13
12 Determination of the percentage total elongation at maximum force (A_{gt}).....	14
13 Determination of proof strength, non proportional extension (R_p).....	14
14 Determination of proof strength, total extension (R_t)	15
15 Method of verification of permanent set strength (R_r).....	15
16 Determination of percentage reduction of area (Z)	15
17 Test report	15
Annex A (informative) Recommendations concerning the use of computer controlled tensile testing machines.....	28
Annex B (normative) Types of test pieces to be used for thin products : sheets, strips and flats between 0,1 mm and 3 mm thick.....	33
Annex C (normative) Types of test pieces to be used for wire, bars and sections with a diameter or thickness of less than 4 mm	35
Annex D (normative) Types of test pieces to be used for sheets and flats of thickness equal to or greater than 3 mm, and wire, bars and sections of diameter or thickness equal to or greater than 4 mm	36

Annex E (normative) Types of test pieces to be used for tubes	39
Annex F (informative) Measuring the percentage elongation after fracture if the specified value is less than 5 %	41
Annex G (informative) Measurement of percentage elongation after fracture based on subdivision of the original gauge length	42
Annex H (informative) Manual method of determination of the percentage total elongation at maximum force for long products such as bars, wire, rods	44
Annex J (informative) Precision of tensile testing and estimation of the uncertainty of measurement	45
Bibliography	56

Foreword

This European Standard has been prepared by Technical Committee ECISS/TC 1 "Steel - Mechanical testing", the secretariat of which is held by AFNOR.

This European Standard shall be given the status of a national standard, either by publication of an identical text or by endorsement, at the latest by January 2002, and conflicting national standards shall be withdrawn at the latest by January 2002.

This European Standard supersedes EN 10002-1:1990.

The European Standard EN 10002-1 "Metallic materials - Tensile testing - Part 1: Method of test (at ambient temperature)" was approved by CEN on 27 November 1989.

After a first 5 years lifetime, ECISS decided to revise this standard.

The revised prEN 10002-1 was discussed during two meetings of ECISS/TC1/SC1 with the participation of 4 CEN member countries (Belgium, France, Germany, United Kingdom).

EN 10002 was composed of five parts :

Part 1 : Method of test (at ambient temperature)

Part 2 : Verification of the force measuring system of the tensile testing machines

Part 3 : Calibration of force proving instruments used for the verification of uniaxial testing machines

Part 4 : Verification of extensometers used in uniaxial testing

Part 5 : Method of testing at elevated temperature

NOTE Part 2 has been already replaced by EN ISO 7500-1. Parts 3 and 4 will be replaced by corresponding ISO standards.

The annexes B, C, D and E are normative. The annexes A, F, G, H and J are informative.

According to the CEN/CENELEC Internal Regulations, the national standards organizations of the following countries are bound to implement this European Standard: Austria, Belgium, Czech Republic, Denmark, Finland, France, Germany, Greece, Iceland, Ireland, Italy, Luxembourg, Netherlands, Norway, Portugal, Spain, Sweden, Switzerland and the United Kingdom.

1 Scope

This European Standard specifies the method for tensile testing of metallic materials and defines the mechanical properties which can be determined at ambient temperature.

NOTE Informative annex A indicates complementary recommendations for computer controlled testing machines. It is the intention, based on further developments by manufacturers and users that annex A will become normative in the next revision of this standard.

2 Normative references

This European Standard incorporates by dated or undated reference, provisions from other publications. These normative references are cited at the appropriate places in the text, and the publications are listed hereafter. For dated references, subsequent amendments to or revisions of any of these publications apply to this European Standard only when incorporated in it by amendment or revision. For undated references the latest edition of the publication referred to applies (including amendments).

EN 10002-4, *Metallic materials - Tensile testing - Part 4: Verification of extensometers used in uniaxial testing.*

EN 20286-2, *ISO system of limits and fits - Part 2 : Tables of standard tolerances grades and limits deviations for holes and shafts (ISO 286-2:1988).*

EN ISO 377, *Steel and steel products - Location of samples and test pieces for mechanical testing (ISO 377:1997).*

EN ISO 2566-1, *Steel conversion of elongation values - Part 1 : Carbon and alloy steels (ISO 2566-1:1984).*

EN ISO 2566-2, *Steel conversion of elongation values - Part 2 : Austenitic steels (ISO 2566-2:1984).*

EN ISO 7500-1, *Metallic materials - Verification of static uniaxial testing machines – Part 1: Tension/compression testing machines – Verification and calibration of force measuring (ISO 7500-1:1999).*

3 Principle

The test involves straining a test piece in tension, generally to fracture, for the purpose of determining one or more of the mechanical properties defined in clause 4.

The test is carried out at ambient temperature between 10 °C and 35 °C, unless otherwise specified. Tests carried out under controlled conditions shall be made at a temperature of 23 °C ± 5 °C.

4 Terms and definitions

For the purpose of this European Standard, the following terms and definitions apply :

4.1

gauge length (L)

length of the cylindrical or prismatic portion of the test piece on which elongation is measured. In particular, a distinction is made between :

4.1.1

original gauge length (L_0)

gauge length before application of force

4.1.2

final gauge length (L_u)

gauge length after rupture of the test piece (see 11.1)

4.2

parallel length (L_c)

parallel portion of the reduced section of the test piece

EN 10002-1:2001 (E)

NOTE The concept of parallel length is replaced by the concept of distance between grips for non-machined test pieces.

4.3 elongation

increase in the original gauge length (L_0) at any moment during the test

4.4 percentage elongation

elongation expressed as a percentage of the original gauge length (L_0)

4.4.1 percentage permanent elongation

increase in the original gauge length of a test piece after removal of a specified stress (see 4.9), expressed as a percentage of the original gauge length (L_0)

4.4.2 percentage elongation after fracture (A)

permanent elongation of the gauge length after fracture ($L_u - L_0$), expressed as a percentage of the original gauge length (L_0)

NOTE In the case of proportional test pieces, only if the original gauge length is other than $5,65 \sqrt{S_0}$ ¹⁾ where S_0 is the original cross-sectional area of the parallel length, the symbol A should be supplemented by an index indicating the coefficient of proportionality used, for example :

$A_{11,3}$ = percentage elongation of a gauge length (L_0) of $11,3 \sqrt{S_0}$.

In the case of non-proportional test pieces, the symbol A should be supplemented by an index indicating the original gauge length used, expressed in millimetres, for example :

$A_{80 \text{ mm}}$ = percentage elongation of a gauge length (L_0) of 80 mm.

4.4.3 percentage total elongation at fracture (A_t)

total elongation (elastic elongation plus plastic elongation) of the gauge length at the moment of fracture expressed as a percentage of the original gauge length (L_0)

4.4.4 percentage elongation at maximum force

increase in the gauge length of the test piece at maximum force, expressed as a percentage of the original gauge length (L_0)

NOTE A distinction is made between the percentage total elongation at maximum force (A_{gt}) and the percentage non-proportional elongation at maximum force (A_g) (see Figure 1).

4.5 extensometer gauge length (L_e)

length of the parallel portion of the test piece used for the measurement of extension by means of an extensometer

NOTE It is recommended that for measurement of yield and proof strength parameters $L_e \geq L_0/2$. It is further recommended that for measurement of parameters "at" or "after" maximum force, L_e is approximately equal to L_0 .

4.6 extension

increase in the extensometer gauge length (L_e) at a given moment of the test

¹⁾ $5,65 \sqrt{S_0} = 5 \sqrt{\frac{4S_0}{\pi}}$.

4.6.1**percentage permanent extension**

increase in the extensometer gauge length, after removal from the test piece of a specified stress, expressed as a percentage of the extensometer gauge length (L_e)

4.6.2**percentage yield point extension (A_e)**

in discontinuous yielding materials, the extension between the start of yielding and the start of uniform work hardening

NOTE It is expressed as a percentage of the extensometer gauge length (L_e).

4.7**percentage reduction of area (Z)**

maximum change in cross-sectional area which has occurred during the test ($S_o - S_u$) expressed as a percentage of the original cross-sectional area (S_o)

4.8**maximum force (F_m)**

the greatest force which the test piece withstands during the test once the yield point has been passed

For materials, without yield point, it is the maximum value during the test.

4.9**stress**

force at any moment during the test divided by the original cross-sectional area (S_o) of the test piece

4.9.1**tensile strength (R_m)**

stress corresponding to the maximum force (F_m)

4.9.2**yield strength**

when the metallic material exhibits a yield phenomenon, stress corresponding to the point reached during the test at which plastic deformation occurs without any increase in the force. A distinction is made between :

4.9.2.1**upper yield strength (R_{eH})**

value of stress at the moment when the first decrease in force is observed (see Figure 2)

4.9.2.2**lower yield strength (R_{eL})**

lowest value of stress during plastic yielding, ignoring any initial transient effects (see Figure 2)

4.9.3**proof strength, non-proportional extension (R_p)**

stress at which a non-proportional extension is equal to a specified percentage of the extensometer gauge length (L_e) (see Figure 3)

NOTE The symbol used is followed by a suffix giving the prescribed percentage, for example : $R_{p0,2}$.

4.9.4**proof strength, total extension (R_t)**

stress at which total extension (elastic extension plus plastic extension) is equal to a specified percentage of the extensometer gauge length (L_e) (see Figure 4)

NOTE The symbol used is followed by a suffix giving the prescribed percentage for example : $R_{t0,5}$.

EN 10002-1:2001 (E)

4.9.5

permanent set strength (R_r)

stress at which, after removal of force, a specified permanent elongation or extension expressed respectively as a percentage of the original gauge length (L_0) or extensometer gauge length (L_e) has not been exceeded (see Figure 5)

NOTE The symbol used is followed by a suffix giving the specified percentage of the original gauge length (L_0) or of the extensometer gauge length (L_e), for example : $R_{r0,2}$.

4.10

fracture

phenomena which is deemed to occur when total separation of the test piece occurs or force decreases to become nominally zero

5 Symbols and designations

Symbols and corresponding designations are given in Table 1.

Table 1 — Symbols and designations

Reference number ^a	Symbol	Unit	Designation
			Test piece
1	a^b	mm	Thickness of a flat test piece or wall thickness of a tube
2	b	mm	Width of the parallel length of a flat test piece or average width of the longitudinal strip taken from a tube or width of flat wire
3	d	mm	Diameter of the parallel length of a circular test piece, or diameter of round wire or internal diameter of a tube
4	D	mm	External diameter of a tube
5	L_o	mm	Original gauge length
-	L'_o	mm	Initial gauge length for determination of A_g (see annex H)
6	L_c	mm	Parallel length
-	L_e	mm	Extensometer gauge length
7	L_t	mm	Total length of test piece
8	L_u	mm	Final gauge length after fracture
-	L'_u	mm	Final gauge length after fracture for determination of A_g (see annex H)
9	S_o	mm ²	Original cross-sectional area of the parallel length
10	S_u	mm ²	Minimum cross-sectional area after fracture
-	k	-	Coefficient of proportionality
11	Z	%	Percentage reduction of area : $\frac{S_o - S_u}{S_o} \times 100$
12	-	-	Gripped ends
			Elongation
13	-	mm	Elongation after fracture : $L_u - L_o$
14	A^c	%	Percentage elongation after fracture : $\frac{L_u - L_o}{L_o} \times 100$
15	A_e	%	Percentage yield point extension
-	ΔL_m	mm	Extension at maximum force
16	A_g	%	Percentage non-proportional elongation at maximum force (F_m)
17	A_{gt}	%	Percentage total elongation at maximum force (F_m)
18	A_t	%	Percentage total elongation at fracture
19	-	%	Specified percentage non-proportional extension
20	-	%	Percentage total extension (see R_t)
21	-	%	Specified percentage permanent set extension or elongation

"continued"

Table 1 (concluded)

Reference number ^a	Symbol	Unit	Designation
22	F_m	N	Force Maximum force
			Yield strength - Proof strength - Tensile strength
23	R_{eH}	MPa ^d	Upper yield strength
24	R_{eL}	MPa	Lower yield strength
25	R_m	MPa	Tensile strength
26	R_p	MPa	Proof strength, non-proportional extension
27	R_r	MPa	Permanent set strength
28	R_t	MPa	Proof strength, total extension
-	E	MPa	Modulus of elasticity

^a See Figures 1 to 13.

^b The symbol T is also used in steel tube product standards.

^c See 4.4.2.

^d 1 MPa = 1 N/mm².

6 Test piece

6.1 Shape and dimensions

6.1.1 General

The shape and dimensions of the test pieces depend on the shape and dimensions of the metallic product from which the test pieces are taken.

The test piece is usually obtained by machining a sample from the product or a pressed blank or casting. However products of constant cross-section (sections, bars, wires, etc.) and also as cast test pieces (i.e. for cast irons and non-ferrous alloys) may be tested without being machined.

The cross-section of the test pieces may be circular, square, rectangular, annular or, in special cases, of some other shape.

Test pieces, the original gauge length of which is related to the original cross-sectional area by the equation $L_0 = k \sqrt{S_0}$ are called proportional test pieces. The internationally adopted value for k is 5,65. The original gauge length shall be not less than 20 mm. When the cross-sectional area of the test piece is too small for this requirement to be met with the coefficient k value of 5,65, a higher value (preferably 11,3) or a non-proportional test piece may be used.

In the case of non-proportional test pieces, the original gauge length (L_0) is taken independently of the original cross-sectional area (S_0).

The dimensional tolerances of the test pieces shall be in accordance with the appropriate annexes (see 6.2).

6.1.2 Machined test pieces

Machined test pieces shall incorporate a transition curve between the gripped ends and the parallel length if these have different dimensions. The dimensions of this transition radius may be important and it is recommended that they be defined in the material specification if they are not given in the appropriate annex (see 6.2).

The gripped ends may be of any shape to suit the grips of the testing machine. The parallel length (L_c) or, in the case where the test piece has no transition curve, the free length between the grips, shall always be greater than the original gauge length (L_0).

6.1.3 Non-machined test pieces

If the test piece consists of an unmachined length of the product or of an unmachined test bar, the free length between the grips shall be sufficient for gauge marks to be at a reasonable distance from the grips (see annexes B to E).

As-cast test pieces shall incorporate a transition radius between the gripped ends and the parallel length. The dimensions of this transition radius are important and it is recommended that they be defined in the product standard. The gripped ends may be of any shape to suit the grips of the testing machine. The parallel length (L_c) shall always be greater than the original gauge length (L_0).

6.2 Types

The main types of test pieces are defined in annexes B to E according to the shape and type of product, as shown in Table 2. Other types of test pieces can be specified in product standards.

Table 2 — Main types of test piece according to the product type

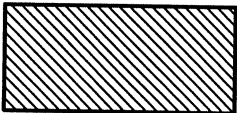
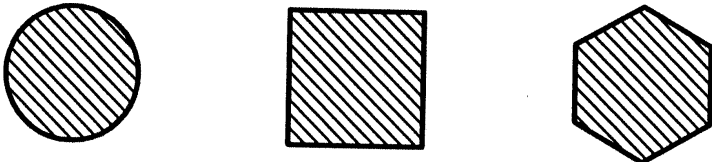
Type of product		Corresponding annex
Sheets – Plates – Flats  With a thickness in millimetres of	Wire - Bars – Sections  with a diameter or side in millimetres of	
0,1 ≤ thickness < 3	-	B
-	< 4	C
≥ 3	≥ 4	D
Tubes		E

6.3 Preparation of test pieces

The test pieces shall be taken and prepared in accordance with the requirements of the relevant European Standards for the different materials (e.g. EN ISO 377, etc.).

7 Determination of original cross-sectional area (S_0)

The original cross-sectional area shall be calculated from the measurements of the appropriate dimensions. The accuracy of this calculation depends on the nature and type of the test piece. It is indicated in annexes B to E for the different types of test pieces.

8 Marking the original gauge length (L_0)

Each end of the original gauge length shall be marked by means of fine marks or scribed lines, but not by notches which could result in premature fracture.

For proportional test pieces, the calculated value of the original gauge length may be rounded off to the nearest multiple of 5 mm, provided that the difference between the calculated and marked gauge length is less than 10 % of L_0 . The original gauge length shall be marked to an accuracy of ± 1 %.

If the parallel length (L_c) is much greater than the original gauge length, as, for instance, with unmachined test pieces, a series of overlapping gauge lengths may be marked.

In some cases, it may be helpful to draw, on the surface of the test piece, a line parallel to the longitudinal axis, along which the gauge lengths are marked.

9 Accuracy of testing apparatus

The force-measuring system of the testing machine shall be calibrated in accordance with EN ISO 7500-1 and shall be at least of class 1.

When an extensometer is used it shall be at least of class 1 (according to EN 10002-4) for the determination proof strength (non-proportional extension) ; for other properties (with higher extension) a class 2 extensometer (according to EN 10002-4) can be used.

NOTE For the determination of upper and lower yield strengths, the use of an extensometer is not necessary.

10 Conditions of testing

10.1 Method of gripping

The test pieces shall be held by suitable means such as wedges, screwed grips, parallel jaw faces, shouldered holders, etc.

Every endeavour should be made to ensure that test pieces are held in such a way that the tension is applied as axially as possible, in order to minimize bending. This is of particular importance when testing brittle materials or when determining proof strength (non-proportional extension) or proof strength (total extension) or yield strength.

NOTE In order to obtain a straight test piece and assure the alignment of the test piece and grip arrangement, a preliminary force may be applied provided it does not exceed a value corresponding to 5 % of the specified or expected yield strength. A correction of the extension should only be carried out to take into account the effect of the preliminary force.

10.2 Test rate

10.2.1 General

Unless otherwise specified in the product standard, the test rate shall conform to the following requirements depending on the nature of the material.

NOTE The stress rates in Table 3 and the strain rates referred to throughout 10.2 do not imply specific modes of control by the testing machine.

10.2.2 Yield and proof strengths

10.2.2.1 Upper yield strength (R_{eH})

Within the elastic range and up to the upper yield strength, the rate of separation of the crossheads of the machine shall be kept as constant as possible and within the limits corresponding to the stress rates in Table 3.

Table 3 — Stress rate

Modulus of elasticity of the material (E) MPa	Stress rate MPa·s ⁻¹	
	min	max
< 150 000	2	20
≥ 150 000	6	60

10.2.2.2 Lower yield strength (R_{eL})

If only the lower yield strength is being determined, the strain rate during yield of the parallel length of the test piece shall be between 0,000 25 s⁻¹ and 0,002 5 s⁻¹. The strain rate within the parallel length shall be kept as constant as possible. If this rate cannot be regulated directly, it shall be fixed by regulating the stress rate just before yield begins, the controls of the machine not being further adjusted until completion of yield.

In no case, the stress rate in the elastic range shall exceed the maximum rates given in Table 3.

10.2.2.3 Upper and lower yield strengths (R_{eH} and R_{eL})

If the two yield strengths are determined during the same test, the conditions for determining the lower yield strength shall be complied with (see 10.2.2.2).

10.2.2.4 Proof strength (non-proportional extension) and proof strength (total extension) (R_p and R_t)

The stress rate shall be within the limits given in Table 3.

Within the plastic range and up to the proof strength (non-proportional extension or total extension) the strain rate shall not exceed 0,002 5 s⁻¹.

10.2.2.5 If the testing machine is not capable of measuring or controlling the strain rate, a cross head separation speed equivalent to the stress rate given in Table 3 shall be used until completion of yield.

10.2.3 Tensile strength (R_m)

After determination of the required yield/proof strength properties the test rate may be increased to a strain rate (or equivalent crosshead separation rate) to no greater than 0,008 s⁻¹.

If only the tensile strength of the material is required to be measured, the test rate shall not exceed 0,008 s⁻¹ throughout the test.

11 Determination of percentage elongation after fracture (A)

11.1 Percentage elongation after fracture shall be determined in accordance with the definition given in 4.4.2.

For this purpose, the two broken pieces of the test piece are carefully fitted back together so that their axes lie in a straight line.

Special precautions shall be taken to ensure proper contact between the broken parts of the test piece when measuring the final gauge length. This is particularly important in the case of test pieces of small cross-section and test pieces having low elongation values.

Elongation after fracture ($L_u - L_0$) shall be determined to the nearest 0,25 mm with a measuring device with a sufficient resolution and the value of percentage elongation after fracture shall be rounded to the nearest 0,5 %. If the specified minimum percentage elongation is less than 5 %, it is recommended that special precautions be taken when determining elongation (see annex F).

This measurement is, in principle, valid only if the distance between the fracture and the nearest gauge mark is not less than one third of the original gauge length (L_0). However, the measurement is valid, irrespective of the position of the fracture, if the percentage elongation after fracture is equal to or greater than the specified value.

EN 10002-1:2001 (E)

11.2 For machines capable of measuring extension at fracture using an extensometer, it is not necessary to mark the gauge lengths. The elongation is measured as the total extension at fracture, and it is therefore necessary to deduct the elastic extension in order to obtain percentage elongation after fracture.

In principle, this measurement is only valid if fracture occurs within the extensometer gauge length (L_e). The measurement is valid regardless of the position of the fracture cross-section if the percentage elongation after fracture is equal to or greater than the specified value.

NOTE If the product standard specifies the determination of percentage elongation after fracture for a given gauge length, the extensometer gauge length should be equal to this length.

11.3 If elongation is measured over a given fixed length, it can be converted to proportional gauge length, using conversion formulae or tables as agreed before the commencement of testing (for example as in EN ISO 2566-1 and EN ISO 2566-2).

NOTE Comparisons of percentage elongation are possible only when the gauge length or extensometer gauge length, the shape and area of the cross-section are the same or when the coefficient of proportionality (k) is the same.

11.4 In order to avoid having to reject test pieces in which fracture may occur outside the limits specified in 11.1, the method based on the subdivision of L_o into N equal parts may be used, as described in annex G.

12 Determination of the percentage total elongation at maximum force (A_{gt})

The method consists of determining the extension at maximum force (ΔL_m) on the force-extension diagram obtained with an extensometer.

The percentage total elongation at maximum force shall be calculated from the following equation :

$$A_{gt} = \frac{\Delta L_m}{L_e} \times 100$$

NOTE 1 For some materials which exhibit a flat plateau at maximum force, the percentage total elongation at maximum force is taken at the mid-point of the flat plateau.

NOTE 2 A manual method is described in annex H.

13 Determination of proof strength, non proportional extension (R_p)

13.1 The proof strength (non-proportional extension) is determined from the force-extension diagram by drawing a line parallel to the straight portion of the curve and at a distance from this equivalent to the prescribed non-proportional percentage, for example 0,2 %. The point at which this line intersects the curve gives the force corresponding to the desired proof strength (non-proportional extension). The latter is obtained by dividing this force by the original cross-sectional area of the test piece (S_o) (see Figure 3).

NOTE 1 Sufficient resolution in drawing the force-extension diagram is essential.

If the straight portion of the force-extension diagram is not clearly defined, thereby preventing drawing the parallel line with sufficient precision, the following procedure is recommended (see Figure 6).

When the presumed proof strength has been exceeded, the force is reduced to a value equal to about 10 % of the force obtained. The force is then increased again until it exceeds the value obtained originally. To determine the desired proof strength a line is drawn through the hysteresis loop. A line is then drawn parallel to this line, at a distance from the corrected origin of the curve, measured along the abscissa, equal to the prescribed non-proportional percentage. The intersection of this parallel line and the force-extension curve gives the force corresponding to the proof strength. The latter is obtained by dividing this force by the original cross-sectional area of the test piece (S_0) (see Figure 6).

NOTE 2 Several methods can be used to define the corrected origin of the force-extension curve. A method which may be used is to construct the line parallel to that determined by the hysteresis loop so that it is tangent to the force-extension curve. The point where this line crosses the abscissa is the corrected origin of the force-extension curve (see Figure 6).

13.2 The property may be obtained without plotting the force-extension curve by using automatic devices (microprocessor, etc.), see annex A.

14 Determination of proof strength, total extension (R_t)

14.1 The proof strength (total extension) is determined on the force-extension diagram by drawing a line parallel to the ordinate axis (force axis) and at a distance from this equivalent to the prescribed total percentage extension. The point at which this line intersects the curve gives the force corresponding to the desired proof strength. The latter is obtained by dividing this force by the original cross-sectional area of the test piece (S_0) (see Figure 4).

14.2 The property may be obtained without plotting the force-extension diagram by using automatic devices (see annex A).

15 Method of verification of permanent set strength (R_r)

The test piece is subjected to a force for 10 s to 12 s corresponding to the specified stress and it is then confirmed, after removing the force, that the permanent set extension or elongation is not more than the percentage specified for the original gauge length.

16 Determination of percentage reduction of area (Z)

Percentage reduction of area shall be determined in accordance with the definition given in 4.7.

The two broken pieces of the test piece are carefully fitted back together so that their axes lie in a straight line. The minimum cross-sectional area after fracture (S_U) shall be measured to an accuracy of $\pm 2\%$ (see annexes B to E). The difference between the area (S_U) and the original cross section (S_0) expressed as a percentage of the original area gives the percentage reduction of area.

17 Test report

The test report shall contain at least the following information :

- reference to this standard : EN 10002-1 ;
- identification of the test piece ;
- specified material, if known ;
- type of test piece ;
- location and direction of sampling of test pieces, if known ;
- test results.

EN 10002-1:2001 (E)

In the absence of sufficient data on all types of metallic materials it is not possible, at present, to fix values of uncertainty for the different properties measured by the tensile test.

NOTE 1 For consideration of uncertainty, see annex J, which provides guidance for the determination of uncertainty related to metrological parameters and values obtained from the interlaboratory tests on a group of steels and aluminium alloys.

NOTE 2 Results should be presented to at least the following :

- strength values to the nearest whole number in MPa;
- percentage elongation values to 0,5%;
- percentage reduction of area to 1%.

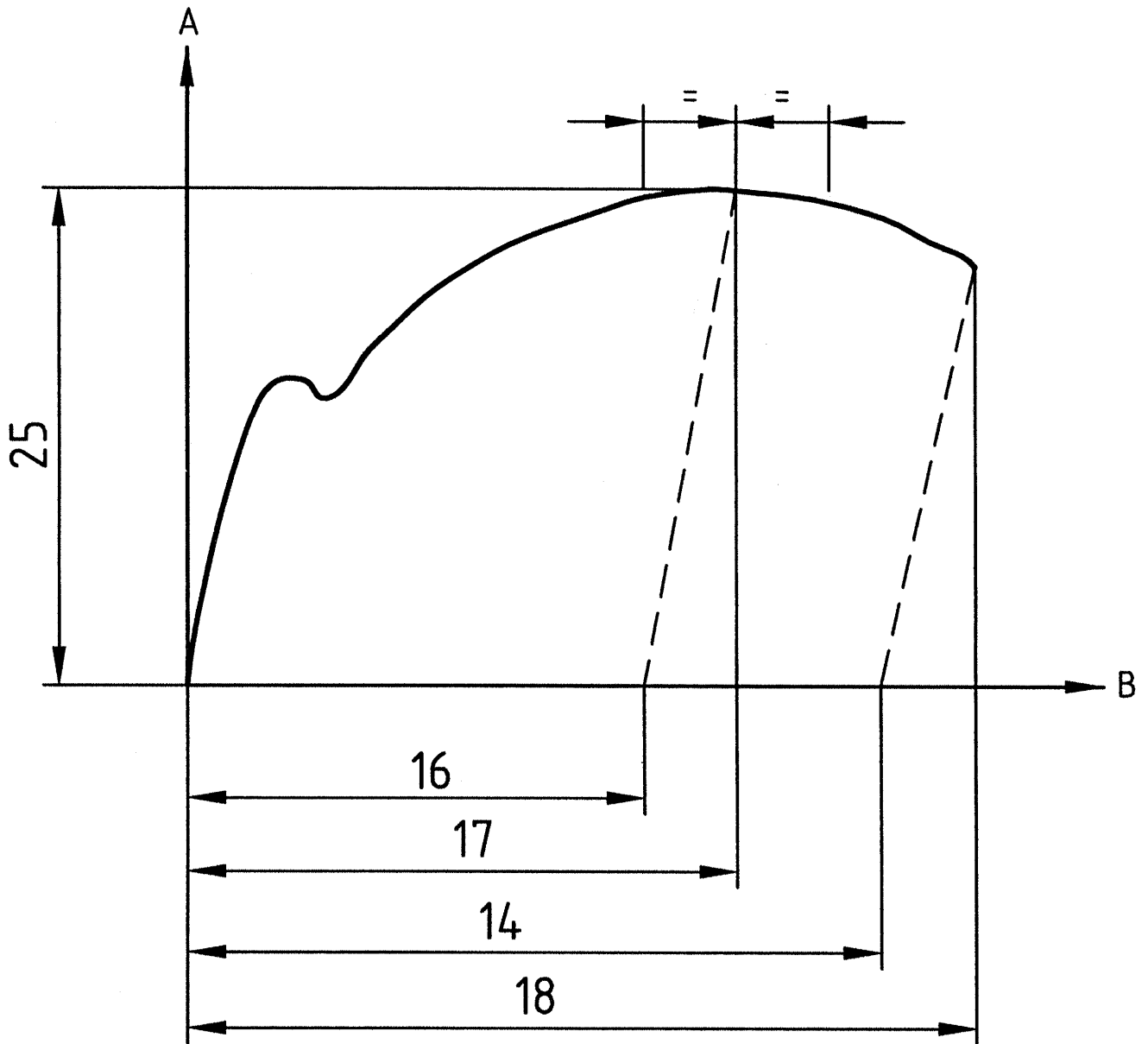

Key

A Stress

B Percentage elongation

NOTE See Table 1 for explanation of reference numbers.

Figure 1 - Definitions of elongation

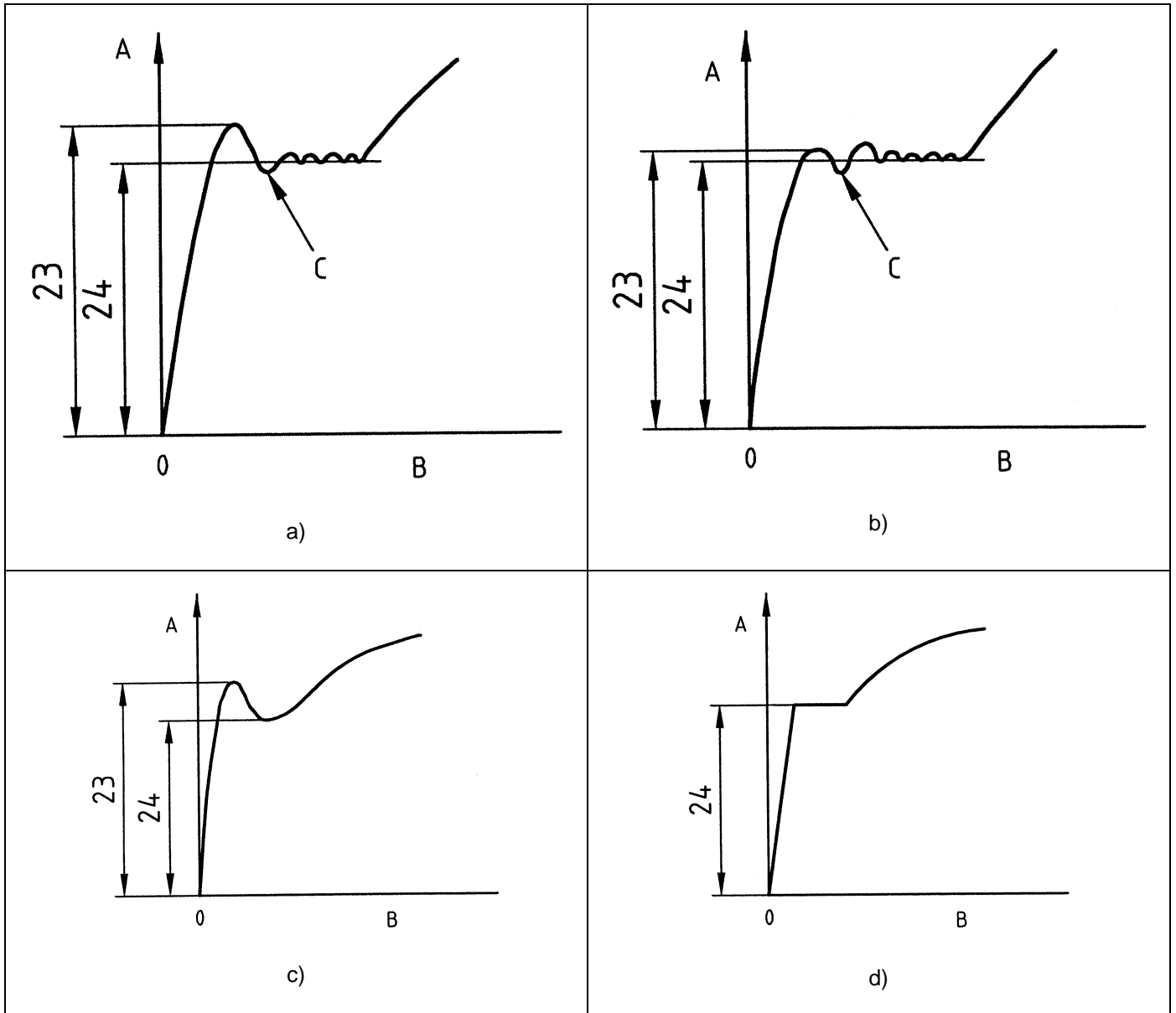

Key

- A Stress
- B Percentage elongation
- C Initial transient effect

NOTE See Table 1 for explanation of reference numbers.

Figure 2 - Definitions of upper and lower yield strengths for different types of curves

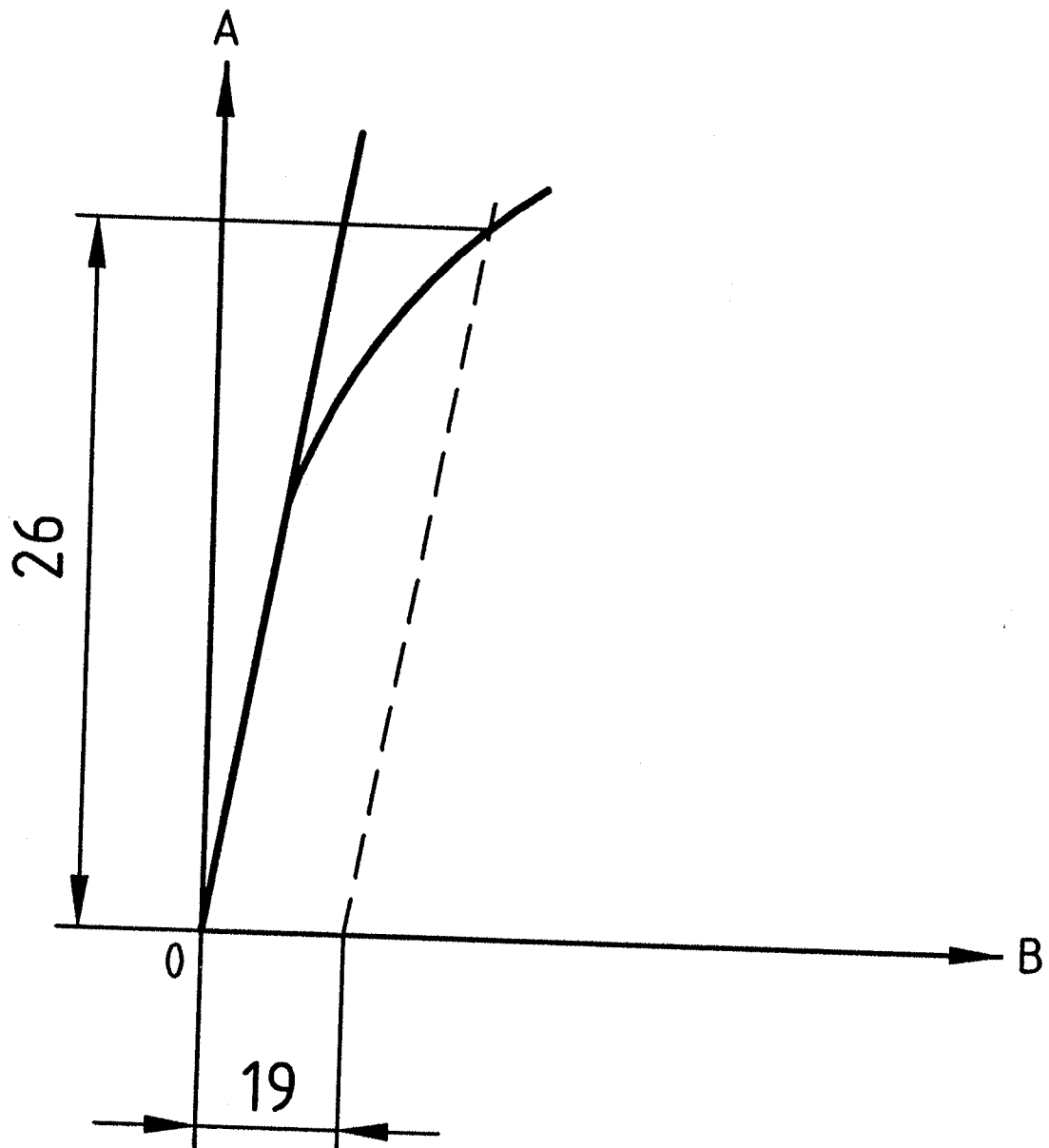
**Key**

- A Stress
- B Percentage elongation or percentage extension

Figure 3 - Proof strength, non-proportional extension (R_p)

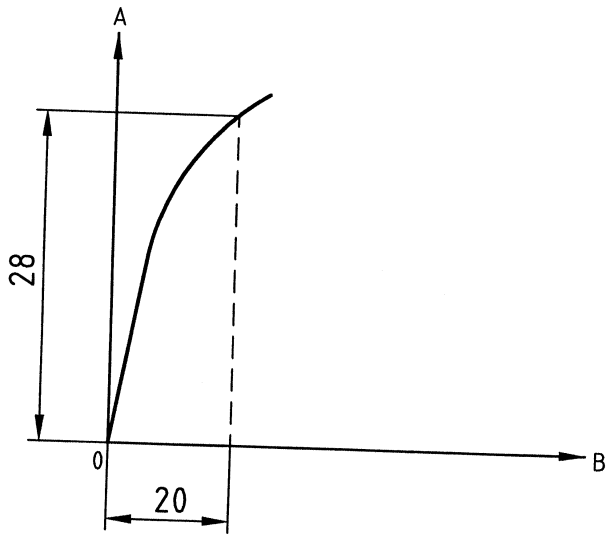

Key

- A Stress
- B Percentage extension

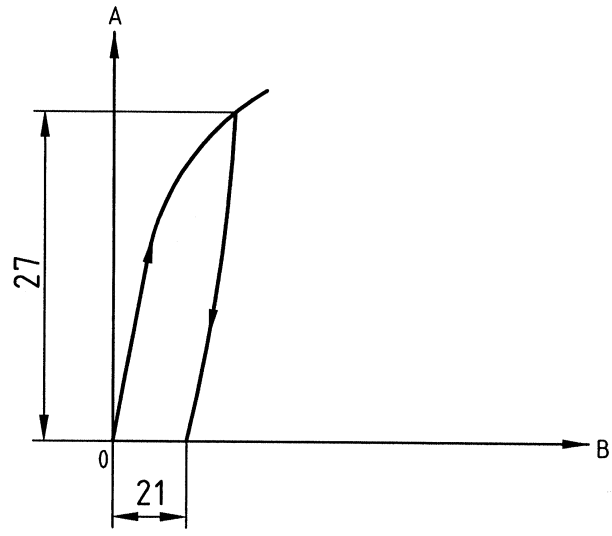

Key

- A Stress
- B Percentage elongation or percentage extension

NOTE See Table 1 for explanation of reference numbers.

Figure 4 - Proof strength, total extension (R_t)

Figure 5 - Permanent set strength (R_r)

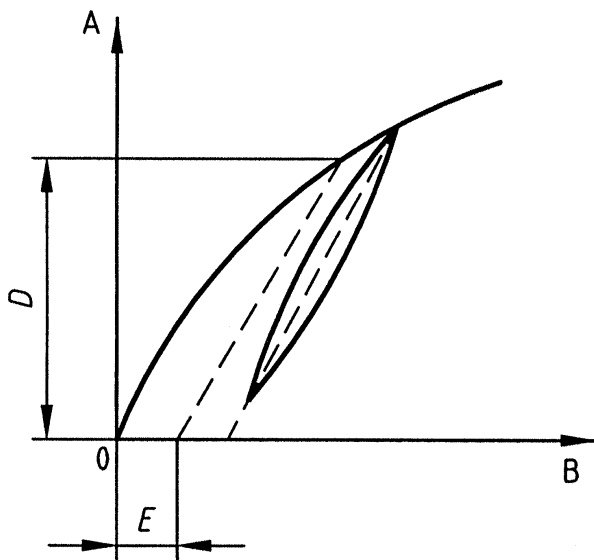

Key

- A Force
- B Percentage extension
- D Force corresponding to R_p
- E Specified non-proportional extension

Figure 6 - Proof strength, non-proportional extension (R_p) (see 13.1)

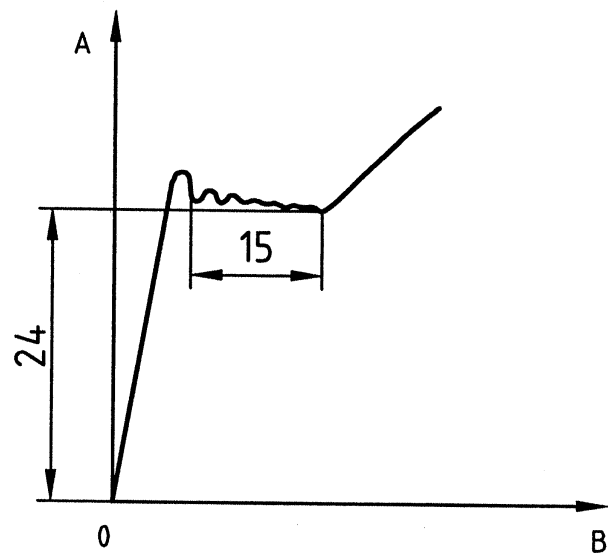

Key

- A Stress
- B Percentage extension

Figure 7 - Percentage yield point extension (A_e)

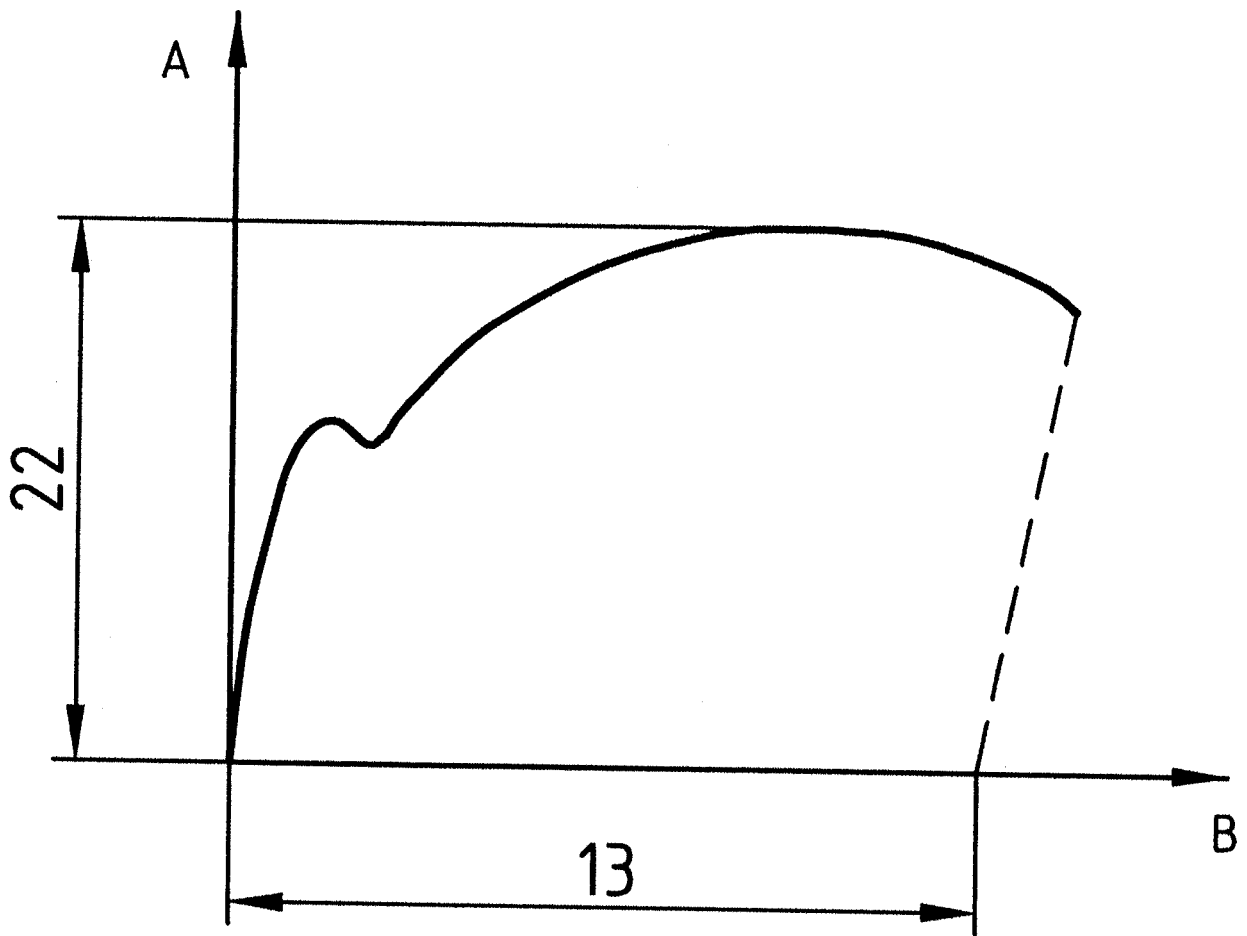

Key

A Force

B Elongation

NOTE See Table 1 for explanation of reference numbers.

Figure 8 - Maximum force (F_m)

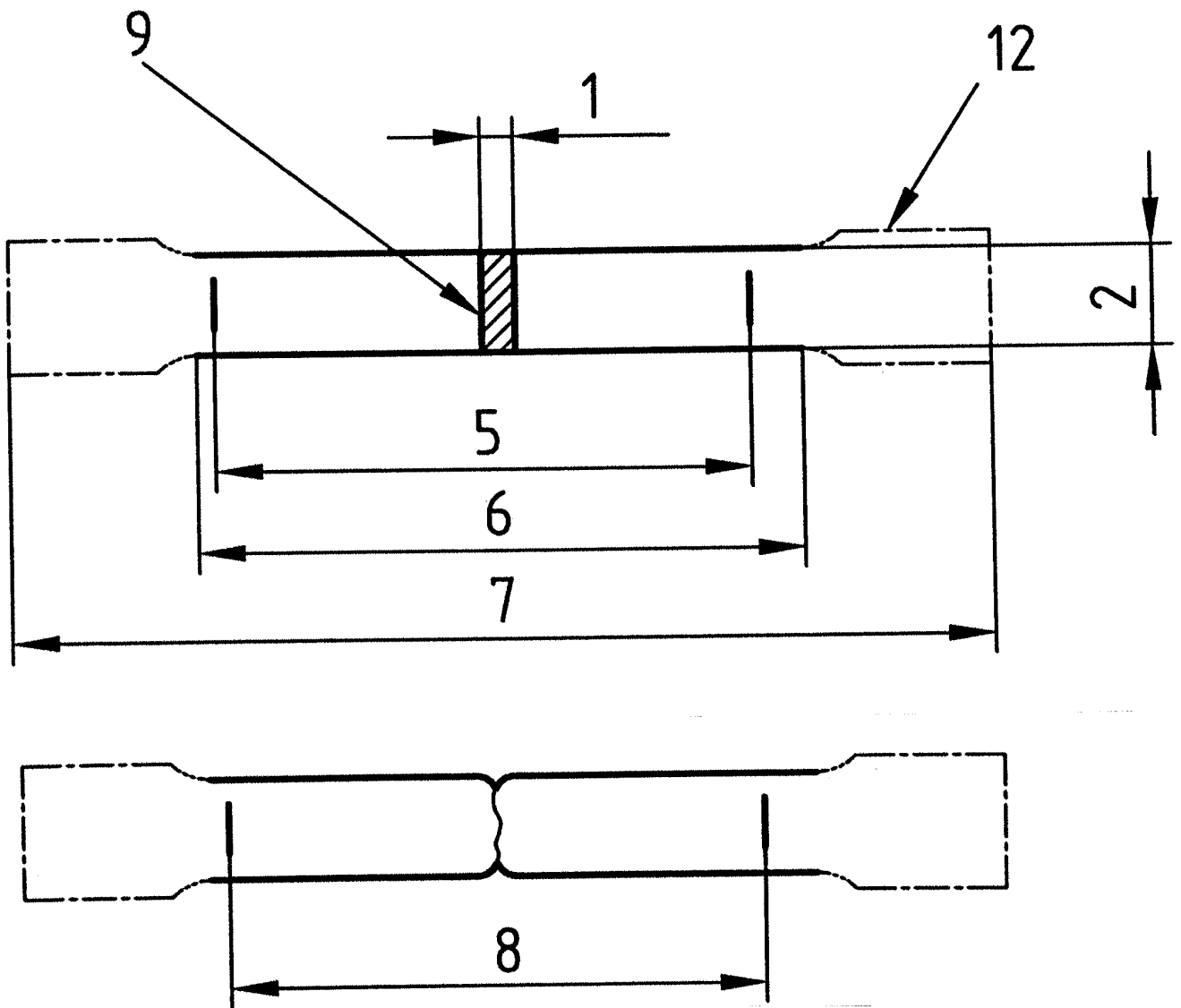
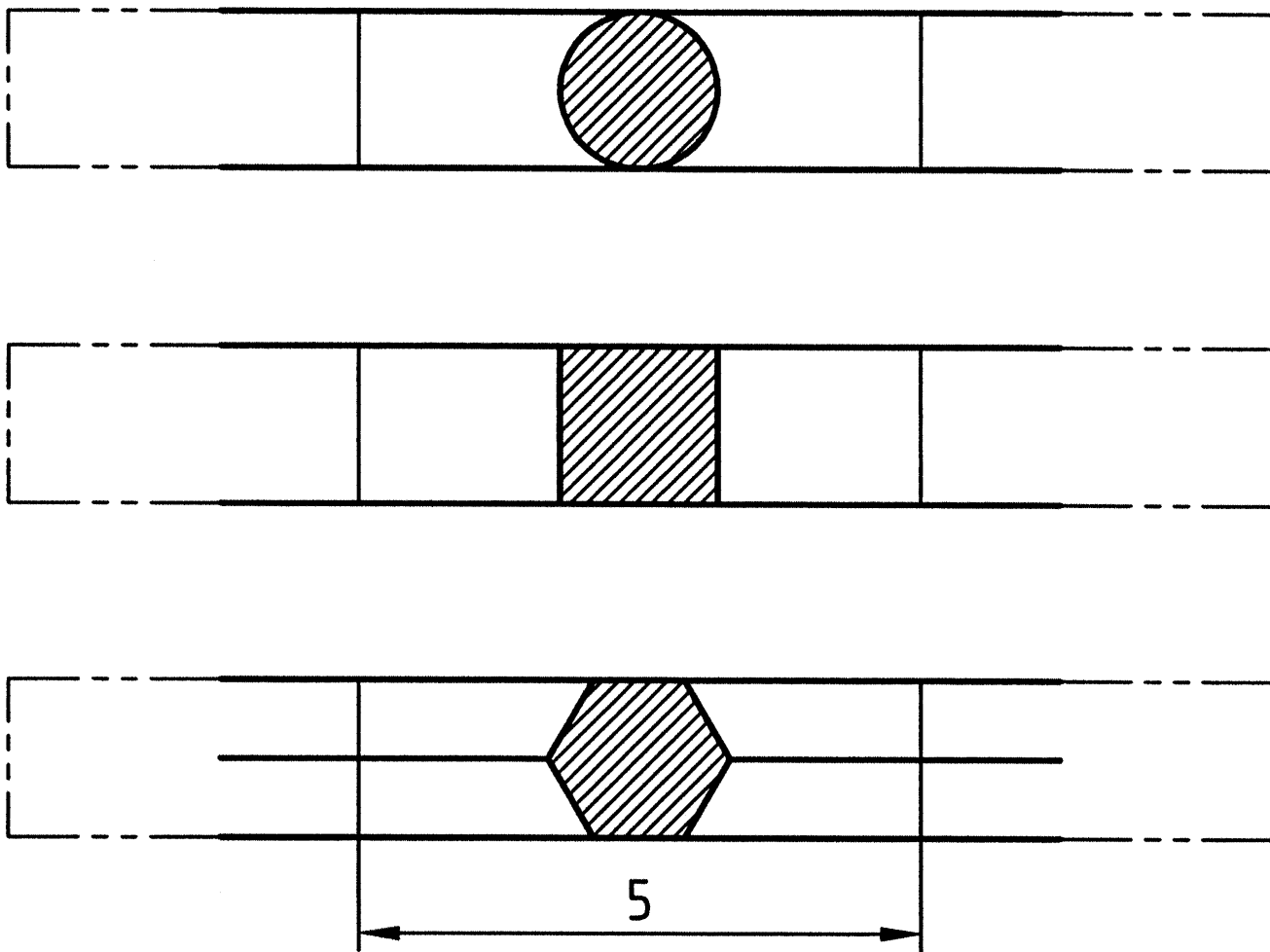

Figure 9 - Machined test pieces of rectangular cross section (see annex B)



NOTE 1 The shape of the test piece heads is given only as a guide.

NOTE 2 See Table 1 for explanation of reference numbers.

Figure 10 – test pieces comprising a non-machined portion of the product (see annex C)

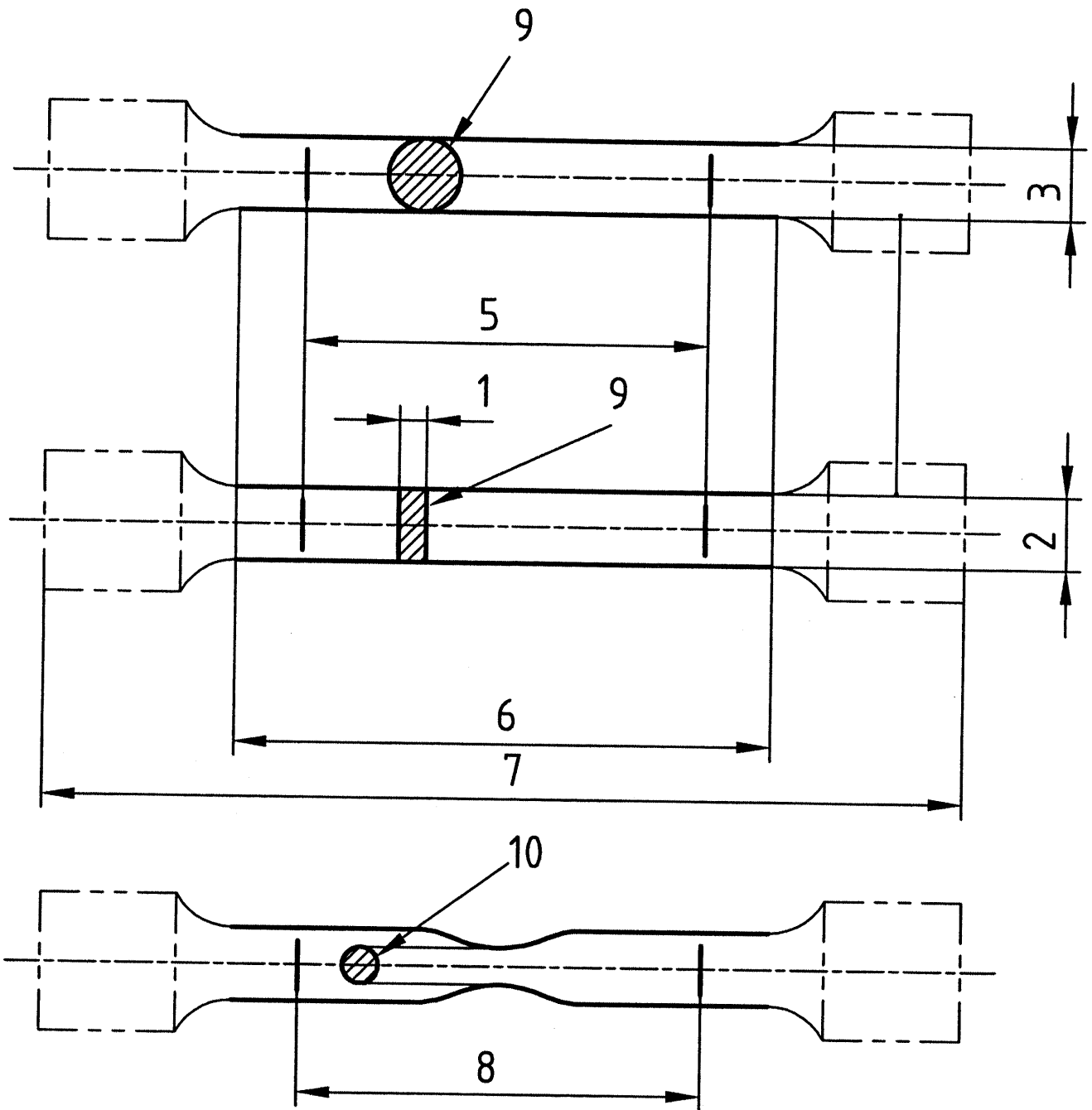

NOTE The shape of the test piece heads is given only as a guide.

Figure 11 - Proportional test pieces (see annex D)

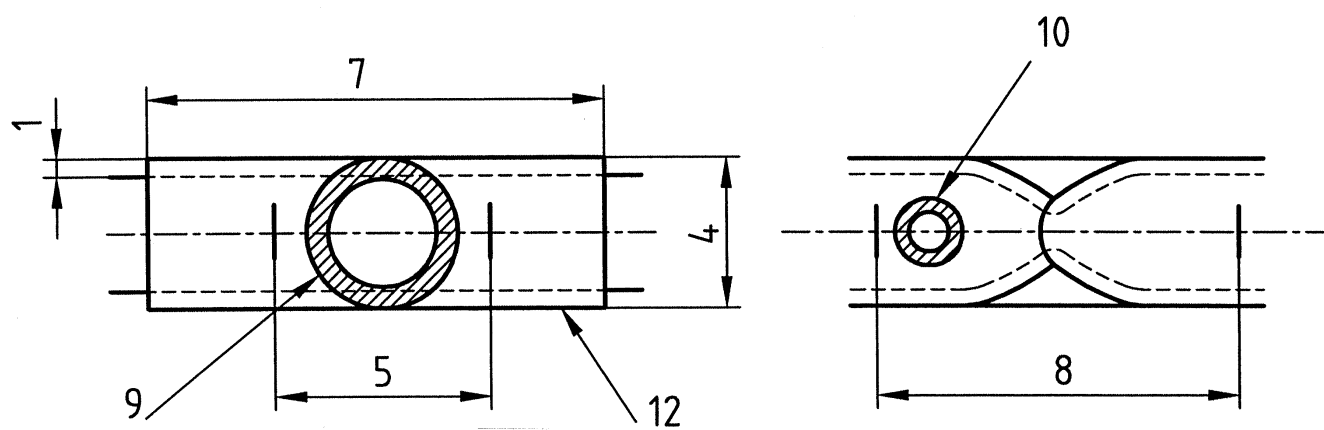

NOTE See Table 1 for explanation of reference numbers.

Figure 12 - Test pieces comprising a length of tube (see annex E)

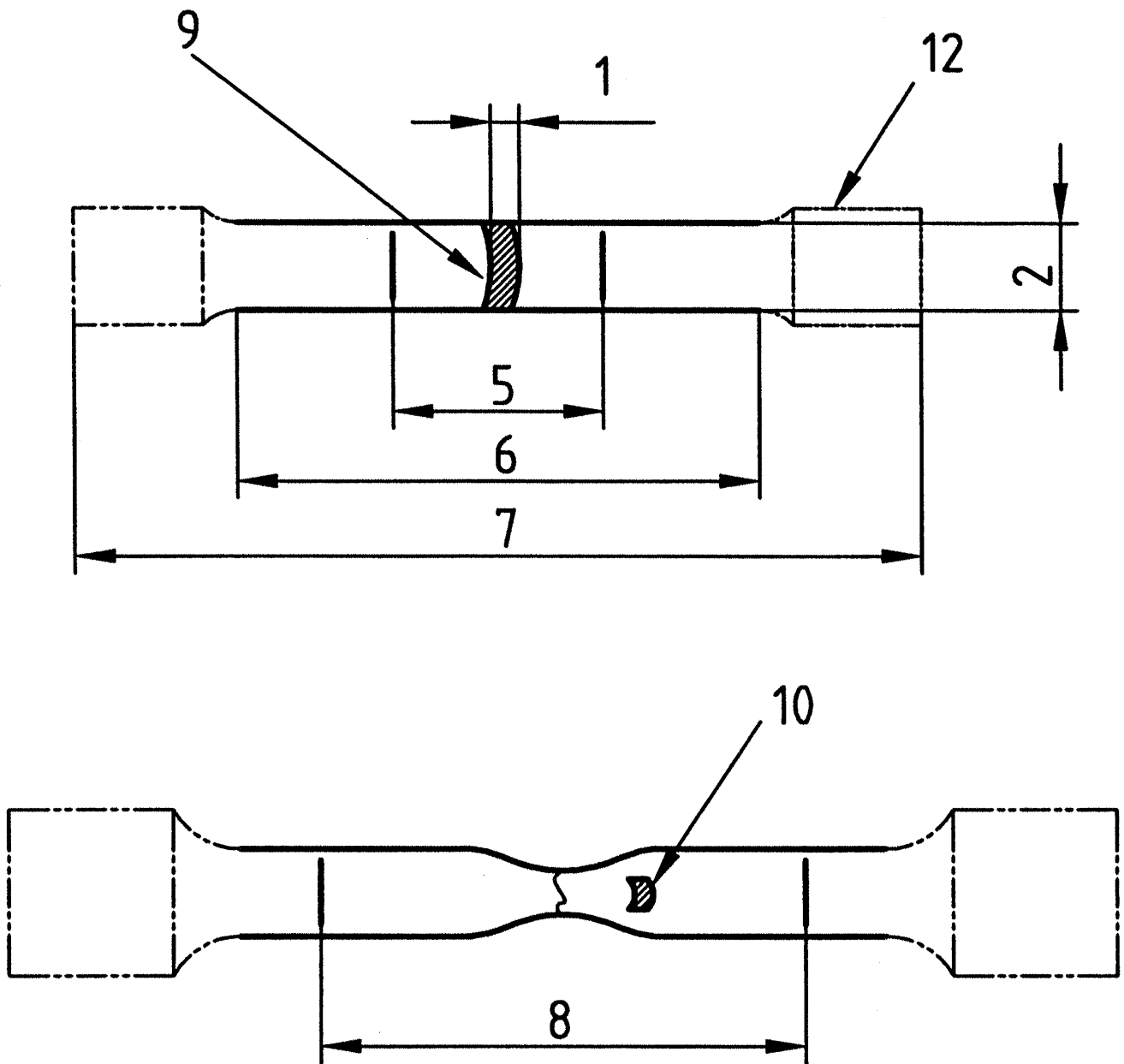

NOTE 1 The shape of the test piece heads is given only as a guide.

NOTE 2 See Table 1 for explanation of reference numbers.

Figure 13 - Test piece cut from a tube (see annex E)

Annex A (informative)

Recommendations concerning the use of computer controlled tensile testing machines

A.1 General

This annex contains recommendations for the determination of mechanical properties by using a computer controlled tensile testing machine. In particular it provides the recommendations which should be taken into account in the software and testing conditions.

These recommendations are related to the design, the software of the machine and its validation and to the operating conditions of the tensile test.

A.2 Terms and definitions

For the purposes of this annex, the following term and definition applies :

A.2.1

Computer controlled tensile testing machine

machine for which the control and monitoring of the test, the measurements and the data processing are undertaken by computer

A.3 Tensile testing machine

A.3.1 Design

The machine should be designed in order to provide outputs giving analogue signals untreated by the software. If such outputs are not provided, the machine manufacturer should give raw digital data with information how these raw digital data have been obtained and treated by the software. They should be given in basic SI units relating to the force, the extension, the time and the test piece dimensions. These data should be revised if the machine is modified.

A.3.2 Data sampling frequency

The frequency bandwidth of the mechanical and electronic components of each of the measurements channels and the data sampling frequency should be sufficiently high as to be able to record the material characteristics required to be measured.

For example to capture R_{eH} , the following formula may be used to determine the minimum sampling frequency :

$$f_{\min} = \frac{\dot{\sigma}}{R_{eH} \times q} \times 100 \quad (\text{A.1})$$

where

f_{\min} is the minimum sampling frequency in s^{-1} ;

$\dot{\sigma}$ is the stress rate in $\text{MPa}\cdot\text{s}^{-1}$;

R_{eH} is the upper yield strength in MPa ;

q is the relative accuracy error of the machine (according to EN ISO 7500-1).

NOTE 1 The choice of R_{eH} in the formula (A.1) is due to the fact that it corresponds to a transient characteristic during the test. If the material tested has no yield phenomena, the proof strength $R_{p0,2}$ should be used.

NOTE 2 In case where the machine is operating in strain rate control, the stress rate should be calculated taking into account the modulus of elasticity of the material.

A.4 Determination of the mechanical properties

A.4.1 General

The following requirements should be taken into account by the software of the machine.

A.4.2 Upper yield strength (R_{eH})

R_{eH} as defined in 4.9.2.1 should be considered as the stress corresponding to the highest value of the force prior to a reduction of at least 0,5 % of the force and followed by a region in which the force should not exceed the previous maximum over a strain range not less than 0,05 %.

A.4.3 Lower yield strength (R_{eL})

R_{eL} is defined in 4.9.2.2. However, for productivity of testing a nominal value of R_{eL} may be reported as the lowest stress within the first 0,25 % strain after R_{eH} , not taking into account any initial transient effect. When this procedure is used, it should be recorded in the test report. After determining R_{eL} by this procedure, the test rate may be increased as per 10.1.3.

NOTE This clause only applies to materials having yield phenomena and when A_e is not required to be determined.

A.4.4 Proof strength at non-proportional extension (R_p) and proof strength at total extension (R_t)

These values, see 4.9.3 and 4.9.4, can be determined by interpolation between two points of the smoothed curved.

A.4.5 Tensile strength (R_m)

It is the stress corresponding to the maximum force (F_m), see 4.9.1.

A.4.6 Percentage elongation at fracture (A_t)

A.4.6.1 A_t should be determined with reference to the definition of fracture in Figure A.1.

The fracture is considered to be effective when the force between two measuring points decreases more than 5 times the value of the previous two points followed by a decrease to lower than 3 % of the maximum tensile force.

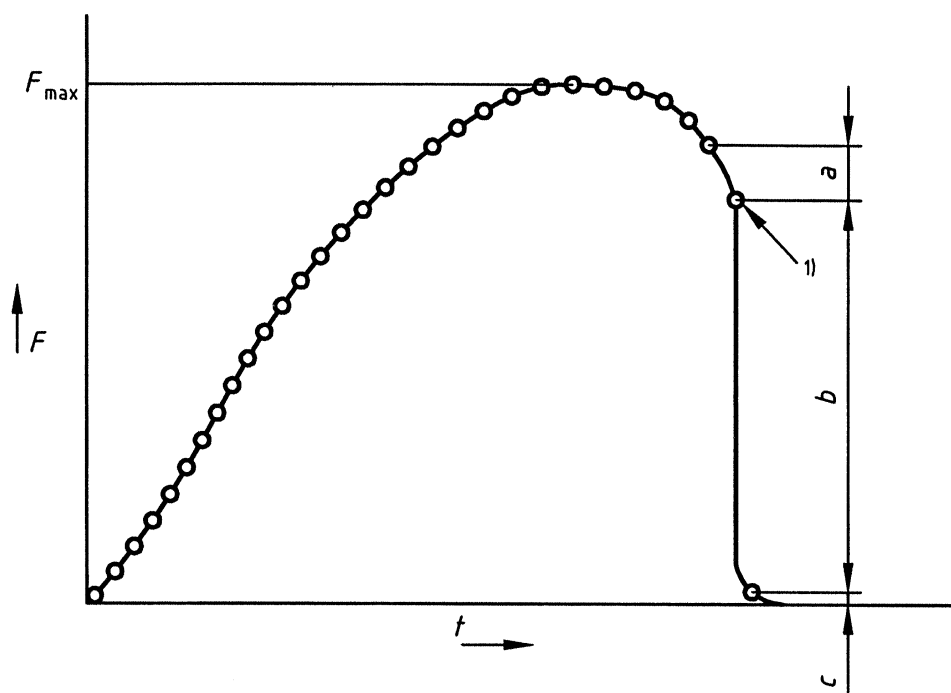

Key

- ° ° Successive measuring points ($f = \text{constant}$)
- b $> 5 a$
- c $< 0,03 F_{\text{max}}$
- 1) Fracture (defined according 4.10)

Figure A.1 - Schematic representation for definition of fracture of the test piece

A.4.6.2 If the extensometer is kept on until the fracture (see 11.2), record the value at point 1 in Figure A.1

A.4.6.3 If the extensometer is removed before fracture, then it is permitted to use crosshead displacement to determine the additional elongation between removal of the extensometer and fracture. The method used should be verifiable.

A.4.7 Percentage yield point extension (A_e)

A method for determining A_e involves assessment of the two particular points in the force-extension curve which define the beginning and end of yield point extension (see reference number 15 in Figure 7). The beginning is at that point where the slope becomes zero and is represented by a horizontal line. The end point can be determined by constructing two lines, the first being horizontal from the last point of zero slope and the second as a tangent to the strain hardening section of the curve as close as possible to the point of inflection. The intersection between these two lines represents the end of yield point extension.

A.4.8 Percentage total elongation at maximum force (A_{gt})

The A_{gt} value as defined in 4.4.2 (see reference number 17 in Figure 1) should be considered as the extension corresponding to the maximum of the stress-strain curve reasonably smoothed after yield point phenomena.

NOTE 1 A three-degree polynomial regression is recommended.

NOTE 2 For some metallic materials (highly cold deformed material like for instance double reduced tin plate or irradiated structural steel), the maximum force is not always occurring at the beginning of necking. In that case, the "Strain-to-necking" can be used for calculating A_{gt} .

A.4.9 Measurement of the slope of the curve in the elastic range

In order to be valid for test pieces of unknown characteristics, the method used should not rely upon any pre-defined stress limit, unless this is defined in the product standard or by agreement between parties to the test.

The methods based on the calculation of the characteristics of a sliding segment are the most convenient. The parameters are :

- the length of the sliding segment (number of points used) ;
- the equation chosen as reference to define the slope of the curve.

NOTE If the straight portion of the force extension diagram is not clearly defined, refer to 13.1.

The slope of the curve in the elastic range corresponds to the mean slope in a range where the following conditions are fulfilled :

- constancy of the slope of the sliding segment is constant;
- this range is representative.

In any case, it should be recommended that pertinent limits for the range can be selected by the user in order to eliminate senseless values of the slope of the curve in the elastic range.

Bibliographic references to these and other acceptable methods are given in Bibliography ([1] to [4]).

A.5 Validation of the software of the machine

The efficiency of the methods used by the testing system to determine the various material characteristics may be checked by comparison with results determined in the traditional manner by examination/calculation from plots of analogue or digital data. Data which are derived directly from the machine transducers or amplifiers should be collected and processed using equipment with frequency band width, sampling frequency and uncertainty at least equal to those used to provide the machine computer calculated results.

Confidence may be placed in the efficiency of the machine computer processing, if differences between computer determined values and those determined by analogue means on the same test piece are small. For the purposes of assessing the acceptability of such differences, five similar test pieces should be tested and the average difference for each relevant property should lie within the limits shown in Table A.1.

NOTE 1 This procedure confirms only that the machine finds the material characteristics for the particular test piece form, material tested and conditions used. It gives no confidence that the properties of the material tested are either correct or fit for purpose.

NOTE 2 If other methods are used, for example, injection of a pre-determined set of data from a known material with a recognised level of quality assurance, these should meet the requirements above mentioned and of Table A.1.

Table A.1 — Conditions for the proof of confidence

Parameter	D^a		s^a	
	Relative ^b	Absolute ^b	Relative ^b	Absolute ^b
$R_{p0,2}$	≤ 0,5 %	2 MPa	≤ 0,35 %	2 MPa
R_{p1}	≤ 0,5 %	2 MPa	≤ 0,35 %	2 MPa
R_{eH}	≤ 1 %	4 MPa	≤ 0,35 %	2 MPa
R_{eL}	≤ 0,5 %	2 MPa	≤ 0,35 %	2 MPa
R_m	≤ 0,5 %	2 MPa	≤ 0,35 %	2 MPa
A		≤ 2 %		≤ 2 %

$$^a D = \frac{1}{n} \sum_{i=1}^n D_i;$$

$$s = \sqrt{\frac{1}{n-1} \sum_{i=1}^n (D_i - D)^2}$$

where

D_i is the difference between the result of manual evaluation (H_i) and the result of computer evaluation (R_i) for a test piece ($D_i = H_i - R_i$);

n is the number of identical test pieces from one sample (≥ 5);

H is the result of manual evaluation ;

R is the result of computer evaluation.

^b The highest of the relative and absolute values should be taken into account.

Annex B (normative)

Types of test pieces to be used for thin products : sheets, strips and flats between 0,1 mm and 3 mm thick

NOTE For products of less than 0,5 mm thickness, special precautions may be necessary.

B.1 Shape of the test piece

Generally, the test piece has gripped ends which are wider than the parallel length. The parallel length (L_c) shall be connected to the ends by means of transition curves with a radius of at least 20 mm. The width of these ends shall be at least 20 mm and not more than 40 mm.

By agreement, the test piece may also consist of a strip with parallel sides. For products of width equal to or less than 20 mm, the width of the test piece may be the same as that of the product.

B.2 Dimensions of the test piece

The parallel length shall not be less than $L_o + \frac{b}{2}$.

In case of dispute, the length $L_o + 2 b$ shall always be used unless there is insufficient material.

In the case of parallel side test pieces less than 20 mm wide, and unless otherwise specified in the product standard, the original gauge length (L_o) shall be equal to 50 mm. For this type of test piece, the free length between the grips shall be equal to $L_o + 3 b$.

There are two types of non-proportional test pieces, with dimensions as given in Table B.1.

When measuring the dimensions of each test piece, the tolerances on shape given in Table B.2 shall apply.

In the case of test pieces where the width is the same as that of the product, the original cross-sectional area (S_o) shall be calculated on the basis of the measured dimensions of the test piece.

The nominal width of the test piece may be used, provided that the machining tolerances and tolerances on shape given in Table B.2 have been complied with, to avoid measuring the width of the test piece at the time of the test.

Table B.1 — Dimensions of test pieces

Dimensions in millimetres				
Test piece type	Width b	Original gauge length L_o	Parallel length L_c	Free length between the grips for parallel sided test piece
1	$12,5 \pm 1$	50	75	87,5
2	20 ± 1	80	120	140

Table B.2 — Tolerances on the width of the test piece

Dimensions and tolerances in millimetres

Nominal width of the test piece	Machining tolerance ^a	Tolerance on shape ^b
12,5	± 0,09	0,043
20	± 0,105	0,052
^a Tolerances js 12 in accordance with EN 20286-2. These tolerances are applicable if the nominal value of the original cross-sectional area (S_0) is to be included in the calculation without having to measure it. ^b Tolerances IT 9 (according to EN 20286-2) maximum deviation between the measurements of the width along the entire parallel length (L_0) of the test piece.		

B.3 Preparation of test pieces

The test pieces shall be prepared so as not to affect the properties of the metal. Any areas which have been hardened by shearing or pressing shall be removed by machining.

For very thin materials, it is recommended that strips of identical widths should be cut and assembled into a bundle with intermediate layers of a paper which is resistant to the cutting oil. It is recommended that each small bundle of strips be assembled with a thicker strip on each side, before machining to the final dimensions of test piece.

The value given in B.2, for example ± 0,09 mm for a nominal width of 12,5 mm, means that no test piece shall have a width outside the two values given below, if the nominal value of the original cross-sectional area (S_0) is to be included in the calculation without having to measure it :

$$12,5 \text{ mm} + 0,09 \text{ mm} = 12,59 \text{ mm}$$

$$12,5 \text{ mm} - 0,09 \text{ mm} = 12,41 \text{ mm.}$$

B.4 Determination of the original cross-sectional area (S_0)

The original cross-sectional area shall be calculated from measurements of the dimensions of the test piece.

The error in determining the original cross-sectional area shall not exceed ± 2 %. As the greatest part of this error normally results from the measurement of the thickness of the test piece, the error in measurement of the width shall not exceed ± 0,2 %.

Annex C (normative)

Types of test pieces to be used for wire, bars and sections with a diameter or thickness of less than 4 mm

C.1 Shape of the test piece

The test piece generally consists of an unmachined portion of the product (see Figure 10).

C.2 Dimensions of the test piece

The original gauge length (L_0) shall be taken as $200 \text{ mm} \pm 2 \text{ mm}$ or $100 \text{ mm} \pm 1 \text{ mm}$. The distance between the grips of the machine shall be equal to at least $L_0 + 50 \text{ mm}$, i.e. 250 mm and 150 mm respectively, except in the case of small diameter wires where this distance can be taken as equal to L_0 .

NOTE In cases where the percentage elongation after fracture is not to be determined, a distance between the grips of at least 50 mm may be used.

C.3 Preparation of test pieces

If the product is delivered coiled, care shall be taken in straightening it.

C.4 Determination of the original cross-sectional area (S_0)

The original cross-sectional area (S_0) shall be determined to an accuracy of $\pm 1 \%$.

For products of circular cross-section, the original cross-sectional area may be calculated from the arithmetic mean of two measurements carried out in two perpendicular directions.

The original cross-sectional area may be determined from the mass of a known length and its density.

Annex D (normative)

Types of test pieces to be used for sheets and flats of thickness equal to or greater than 3 mm, and wire, bars and sections of diameter or thickness equal to or greater than 4 mm

D.1 Shape of the test piece

In general, the test piece is machined and the parallel length shall be connected by means of transition curves to the gripped ends which may be of any suitable shape for the grips of the testing machine (see Figure 11). The minimum transition radius between the grips ends and the parallel length shall be :

- 0,75 d (d being the diameter of the parallel length) for the cylindrical test pieces ;
- 12 mm for the prismatic test pieces.

Sections, bars, etc., may be tested unmachined, if required.

The cross-section of the test piece may be circular, square, rectangular or, in special cases, of another shape.

For test pieces with a rectangular cross-section, it is recommended that the width to thickness ratio should not exceed 8:1.

In general, the diameter of the parallel length of machined cylindrical test pieces shall be not less than 4 mm.

D.2 Dimensions of the test piece

D.2.1 Parallel length of machined test piece

The parallel length (L_0) shall be at least equal to :

- a) $L_0 + \frac{d}{2}$ in the case of test pieces with circular cross-section ;
- b) $L_0 + 1,5 \sqrt{S_0}$ in the case of prismatic test pieces.

Depending on the type of test piece, the length $L_0 + 2d$ or $L_0 + 2 \sqrt{S_0}$ shall be used in cases of dispute, unless there is insufficient material.

D.2.2 Length of unmachined test piece

The free length between the grips of the machine shall be adequate for the gauge marks to be at a reasonable distance from these grips.

D.2.3 Original gauge length (L_0)

D.2.3.1 Proportional test pieces

As a general rule, proportional test pieces are used where the original gauge length (L_0) is related to the original cross-sectional area (S_0) by the equation :

$$L_0 = k \sqrt{S_0}$$

where k is equal to 11,3 or 5,65.

Test pieces of circular cross-section should preferably have the dimensions given in Table D.1.

Table D.1 — Circular cross-section test pieces

k	Diameter d mm	Original cross-section area S_o mm ²	Original gauge length $L_o = k \sqrt{S_o}$ mm	Minimum parallel length L_c mm	Total length L_t
5,65	20 ± 0,150	314	100 ± 1,0	110	Depends on the method of fixing the test piece in the machine grips In principle : $L_t > L_c + 2d$ or $4d$
	10 ± 0,075	78,5	50 ± 0,5	55	
	5 ± 0,040	19,6	25 ± 0,25	28	

D.2.3.2 Non-proportional test pieces

Non-proportional test pieces may be used if specified by the product standard.

The parallel length (L_c) should not be less than $L_o + b/2$. In case of dispute, the parallel length $L_c = L_o + b/2$ shall be used unless there is insufficient material.

Table D.2 gives details of some typical test piece dimensions.

Table D.2 — Typical test piece dimensions

Nominal width b mm	Original gauge length L_o mm	Parallel length (L_c) minimum mm	Approx. total length L_t mm
40	200	225	450
25	200	225	450
20	80	90	300

D.3 Preparation of test pieces

The tolerances on the transverse dimensions of machined test pieces are given in Table D.3.

An example of the application of these tolerances is given below :

a) machining tolerances

The value given in Table D.3, for example ± 0,075 mm for a nominal diameter of 10 mm, means that no test piece shall have a diameter outside the two values given below, if the nominal value of the original cross-sectional area (S_o) is to be included in the calculation without having to measure it :

$$10 \text{ mm} + 0,075 \text{ mm} = 10,075 \text{ mm}$$

$$10 \text{ mm} - 0,075 \text{ mm} = 9,925 \text{ mm}$$

b) tolerances on shape

The value given in Table D.3 means that, for a test piece with a nominal diameter of 10 mm which satisfies the machining conditions given above, the deviation between the smallest and largest diameters measured shall not exceed 0,04 mm.

EN 10002-1:2001 (E)

Consequently, if the minimum diameter of this test piece is 9,99 mm, its maximum diameter shall not exceed $9,99 \text{ mm} + 0,04 \text{ mm} = 10,03 \text{ mm}$.

Table D.3 — Tolerances relating to the transverse dimensions of test pieces

Dimensions and tolerances in millimetres

Designation	Nominal transverse dimension	Machining tolerance on the nominal dimension ^a	Tolerance on shape
Diameter of machined test pieces of circular cross-section	3	$\pm 0,05$	0,025 ^b
	≥ 3 ≤ 6	$\pm 0,06$	0,03 ^b
	> 6 ≤ 10	$\pm 0,075$	0,04 ^b
	> 10 ≤ 18	$\pm 0,09$	0,04 ^b
	> 18 ≤ 30	$\pm 0,105$	0,05 ^b
Transverse dimensions of test pieces of rectangular cross-section machined on all four sides		Same tolerance as on the diameter of test pieces of circular cross-section	
Transverse dimensions of test pieces of rectangular cross-section machined on only two opposite sides	3		0,14 ^c
	≥ 3 ≤ 6		0,18 ^c
	> 6 ≤ 10		0,22 ^c
	> 10 ≤ 18		0,27 ^c
	> 18 ≤ 30		0,33 ^c
	> 30 ≤ 50		0,39 ^c
^a Tolerances js 12 in accordance with EN 20286-2. These tolerances are applicable if the nominal value of the original cross-sectional area (S_0) is to be included in the calculation without having to measure it. ^b Tolerances IT 9 Maximum deviation between the measurements of a specified transverse dimension along the entire parallel length (L_c) of the test piece. ^c Tolerances IT 13 Maximum deviation between the measurements of a specified transverse dimension along the entire parallel length (L_c) of the test piece.			

D.4 Determination of the cross-sectional area (S_0)

The nominal diameter can be used to calculate the original cross-sectional area of test pieces of circular cross-section which satisfy the tolerances given in Table D.3. For all other shapes of test pieces, the original cross-sectional area shall be calculated from measurements of the appropriate dimensions, with an error not exceeding $\pm 0,5 \%$ on each dimension.

Annex E (normative)

Types of test pieces to be used for tubes

E.1 Shape of the test piece

The test piece consists either of a length of tube or a longitudinal or transverse strip cut from the tube and having the full thickness of the wall tube (see Figures 12 and 13), or of a test piece of circular cross-section machined from the wall of the tube.

Machined transverse, longitudinal and circular cross-section test pieces are described in annex B for tube wall thickness less than 3 mm and in annex D for thickness equal to or greater than 3 mm. The longitudinal strip is generally used for tubes with a wall thickness of more than 0,5 mm.

E.2 Dimensions of the test piece

E.2.1 Length of tube

The length of tube may be plugged at both the ends. The free length between each plug and the nearest gauge marks shall exceed $D/4$. In cases of dispute, the value, D , shall be used, as long as there is sufficient material.

The length of the plug projecting relative to the grips of the machine in the direction of the gauge marks shall not exceed D , and its shape shall be such that it does not interfere with the gauge length deformation.

E.2.2 Longitudinal or transverse strip

The parallel length (L_c) of the longitudinal strips shall not be flattened but the gripped ends may be flattened for gripping in the testing machine.

Transverse or longitudinal test piece dimensions other than those given in annexes B and D can be specified in the product standard.

Special precautions shall be taken when straightening the transverse test pieces.

E.2.3 Circular cross-section test piece machined in tube wall

The sampling of the test pieces is specified in the product standard.

E.3 Determination of the original cross-sectional area (S_0)

The original cross-sectional area of the test piece shall be determined to the nearest ± 1 %.

The original cross-sectional area of the length of tube or longitudinal or transverse strip may be determined from the mass of the test piece, the length of which has been measured, and from its density.

EN 10002-1:2001 (E)

The original cross-sectional area (S_0) of a test piece consisting of a longitudinal or transverse strip shall be calculated according to the following equation :

$$S_0 = \frac{b}{4} (D^2 - b^2)^{1/2} + \frac{D^2}{4} \arcsin \left(\frac{b}{D} \right) - \frac{b}{4} [(D - 2a)^2 - b^2]^{1/2} - \left(\frac{D - 2a}{2} \right)^2 \arcsin \left(\frac{b}{D - 2a} \right)$$

where

a is the thickness of the tube wall ;

b is the average width of the strip ;

D is the external diameter of the tube.

The following simplified equations can be used for longitudinal test pieces :

$$S_0 = ab \left[1 + \frac{b^2}{6D(D - 2a)} \right] \text{ when } \frac{b}{D} < 0,25;$$

$$S_0 = ab \text{ when } \frac{b}{D} < 0,17.$$

In the case of length of tube, the original cross-sectional area (S_0) shall be calculated as follows :

$$S_0 = \pi a (D - a)$$

ANNEX F

(informative)

Measuring the percentage elongation after fracture if the specified value is less than 5 %

Precautions should be taken when measuring the percentage elongation after fracture if the specified value is less than 5 %.

One of the recommended methods is as follows :

Prior to the test a very small mark should be made near one of the ends of the parallel length. Using a pair of needle-pointed dividers set at the gauge length, an arc is scribed with the mark as a centre. After fracture, the broken test piece should be placed in a fixture and axial compressive force applied, preferably by means of a screw, sufficient to firmly hold the pieces together during measurement. A second arc of the same radius should then be scribed from the original center, and the distance between the two scratches measured by means of a measuring microscope or other suitable instrument. In order to render the fine scratches more easily visible, a suitable dye film may be applied to the test piece before testing.

Annex G (informative)

Measurement of percentage elongation after fracture based on subdivision of the original gauge length

To avoid having to reject test pieces where the position of the fracture does not comply with the conditions of 11.1, the following method may be used, by agreement :

- a) before the test, subdivide the original gauge length (L_o) into N equal parts ;
- b) after the test, use the symbol X to denote the gauge mark on the shorter piece and the symbol Y to denote on the longer piece, the subdivision which is at the same distance from the fracture as mark X .

If n is the number of intervals between X and Y , the elongation after fracture is determined as follows :

- 1) if $N - n$ is an even number (see Figure G.1 a)), measure the distance between X and Y and the distance from Y to the graduation mark Z located at :

$$\frac{N - n}{2}$$

intervals beyond Y ,

calculate the percentage elongation after fracture using the equation :

$$A = \frac{XY + 2YZ - L_o}{L_o} \times 100$$

- 2) if $N - n$ is an odd number (Figure G.1 b)), measure the distance between X and Y and the distance from Y to the graduation marks Z' and Z'' located respectively at :

$$\frac{N - n - 1}{2} \text{ and } \frac{N - n + 1}{2}$$

intervals beyond Y ,

calculate the percentage elongation after fracture using the equation :

$$A = \frac{XY + YZ' + YZ'' - L_o}{L_o} \times 100$$

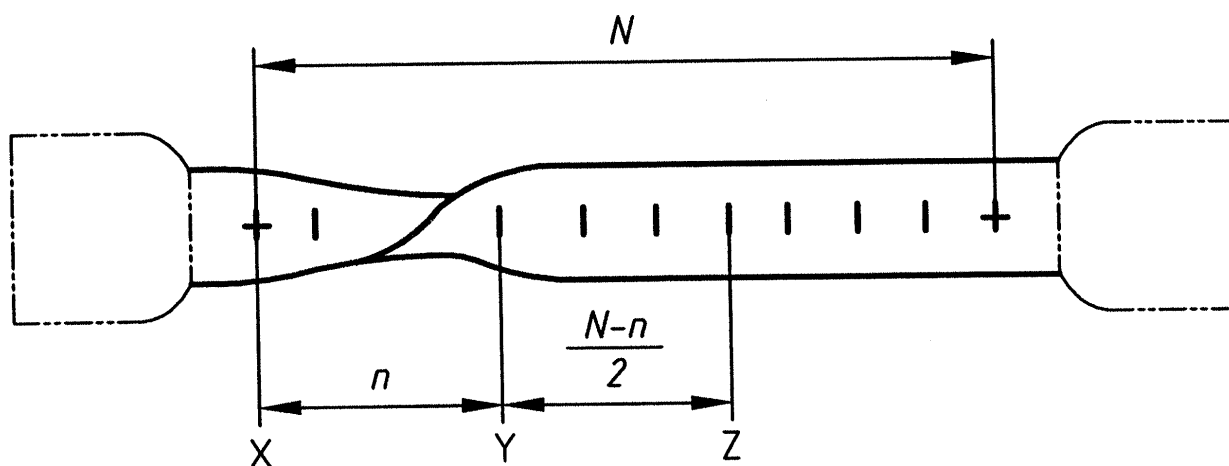

a) $N-n$ is an even number

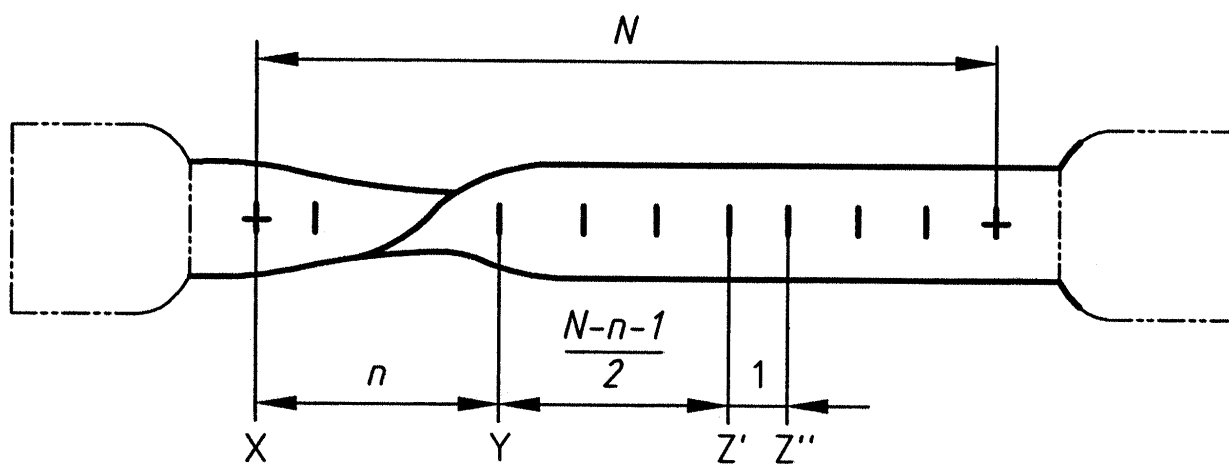

b) $N-n$ is an odd number

NOTE The shape of the test piece heads is given only as a guide.

Figure G.1 - Examples of measurement of percentage elongation after fracture

Annex H (informative)

Manual method of determination of the percentage total elongation at maximum force for long products such as bars, wire, rods

The extensometer method defined in clause 12 may be replaced by the following manual method. In case of dispute, the extensometer method shall be used.

The method consists of measuring on the longer part of a broken test piece which has been submitted to a tensile test, the percentage non-proportional elongation at maximum force, from which the percentage total elongation at maximum force is calculated.

Before the test, equidistant marks are made on the measuring gauge length, the distance between 2 successive marks being equal to a submultiple of the initial gauge length (L'_0). The marking of the initial gauge length (L'_0) should be accurate to within $\pm 0,5$ mm. This length which is function of the value of the percentage total elongation should be defined in the product standard.

The measurement of the final gauge length after fracture (L'_u) is made on the longest broken part of the test piece and should be accurate to within 0,5 mm.

In order that the measurement is valid, the two following conditions should be respected :

- the limits of the measuring zone should be located at least $5 d$ from the fracture section and at least $2,5 d$ from the grip ;
- the measuring gauge length should be at least equal to the value specified in the product standard.

The percentage non-proportional elongation at maximum force is calculated by the following formula :

$$A_g = \frac{L'_u - L'_0}{L'_0} \times 100$$

The percentage total elongation at maximum force is calculated by the following formula :

$$A_{gt} = A_g + \frac{R_m}{E} \times 100$$

Annex J (informative)

Precision of tensile testing and estimation of the uncertainty of measurement

J.1 Introduction

This annex gives guidance of how to estimate the uncertainty of the measurements undertaken in accordance with this standard using a material with known tensile properties. It should be noted that it is not possible to give an absolute statement of uncertainty for this test method because there are both **material dependent** and **material independent** contributions to the uncertainty statement. Hence it is necessary to have a prior knowledge of a material's tensile response to strain or stress rate before being able to calculate the measurement uncertainty.

An approach for estimating the uncertainty of measurement using the "error budget" concept based upon the tolerances specified in the testing and calibration standards has been presented elsewhere [5] and was subsequently expanded to form the basis of the annex J of ISO 6892 (1998) [6]. This annex has now been revised to more closely follow the approach for estimating the uncertainty of measurement outlined in the guide established by ISO TAG4 [7].

The precision of the test results from a tensile test is dependent upon factors related to the material being tested, the test piece geometry and machining, the testing machine, the test procedure and the methods used to calculate the specified material properties. Ideally all the following factors should be considered:

- measurement of the test piece dimensions, gauge length marking, extensometer gauge length ;
- measurement of force and extension ;
- test temperature and loading rates in the successive stages of the test ;
- the method of gripping the test piece and the axially of the application of the force ;
- the testing machine characteristics (stiffness, drive, method and control of operation) ;
- human and software errors associated with the determination of the tensile properties ;
- the material inhomogeneity which exists even within a single processed batch obtained from a single melt of material.

In practice the requirements and tolerances of the present standard do not allow all the effects to be quantified. However interlaboratory tests may be used to determine the overall uncertainty of results under conditions close to those used at industrial laboratories, but such tests do not separate effects related to the material inhomogeneity from those attributable to the testing method.

EN 10002-1:2001 (E)

It should be appreciated that it is not possible to calculate a single value for the measurement uncertainty for all materials since different materials exhibit different response characteristics to some of the specified control parameters, e.g. strain rate or stress rate [5]. The uncertainty budget presented here could be regarded as an upper bound to the measurement uncertainty for a laboratory undertaking testing in compliance with EN 10002-1 since it is possible that a laboratory could actually control some of the testing parameters to a better level of precision than that demanded by the standard, e.g. the force might be measured to $\pm 0,5\%$ (i.e., a Class 0,5 machine) whereas the testing standard EN 10002-1 only requires that the force is measured within $\pm 1\%$. It should be noted that when evaluating the total scatter in experimental results the uncertainty in measurement should be considered in addition to the inherent scatter due to material inhomogeneity. A statistical approach to the analysis of intercomparison exercises (Round Robin experiments) does not separate out the two contributing causes of the scatter but nevertheless gives a useful indication of the likely range of tensile results measured by different laboratories using similar material. Typical results from various intercomparison exercises are given in J.5.

J.2 An Overview of Uncertainty Estimation based upon the GUM

The "Guide to the expression of uncertainty in measurement", was published jointly by several authoritative standards bodies, namely BIPM, IEC, IFCC, ISO, IUPAC, IUPAP and OIML. It will be referred to hereafter as GUM (Guide to Uncertainty in Measurement). It is a comprehensive document of over 90 pages based upon rigorous statistical methods for the summation of uncertainties from various sources. Its complexity has provided the driving force for a number of organisations to produce simplified versions of the GUM, [8], [9], [10]. These various documents all give guidance of how to estimate uncertainty of measurement based upon an "uncertainty budget" concept. For detailed descriptions, see [11] and [12].

J.3 Tensile testing : Uncertainty estimation

J.3.1 Material Independent Parameters

The tolerances for the various testing parameters for tensile properties are given in Table J.1. Because of the shape of the stress-strain curve, some of the tensile properties in principle can be determined with a higher degree of precision than others, e.g., the upper yield strength R_{eH} is only dependent on the tolerances for measurement of force and cross sectional area, whilst proof strength, R_p , is dependent on force, strain (displacement), gauge length and cross-sectional area. In the case of reduction in area, Z , the measurement tolerance for cross-sectional area both before and after fracture needs to be considered.

Table J.1 — Measurement uncertainty for tensile testing based upon material independent parameters using tolerances specified in EN 10002-1

Parameter	Tensile properties, % error					
	R_{eH}	R_{eL}	R_m	R_p	A	Z
Force	1	1	1	1		
Strain ^a (displacement)	-	-	-	1 ^b	1	
Gauge length, L_o ^a	-	-	-	1 ^b	1	
S_o	1	1	1	1	-	1
S_u	-	-	-	-	-	2

^a Assuming a class 1 extensometer calibrated in accordance with EN 10002-4.

^b In determination of the proof strength, R_p , an error of $\pm 1\%$ is an over-estimate. The error depends on the slope of the force-extension diagram and is definitely smaller than calculated below. The determination of a quantitative value is only possible with a known force-extension curve, which implies the quantitative value being dependent on the material.

In the GUM two types of uncertainty are categorised : Types A and B. A type A evaluation of uncertainty may be based on any valid statistical method for treating data. A type B evaluation is based on some other means ; Thus the use of tolerances specified in a standard comes under the type B category. The tolerances shown above for tensile testing represent maximum bound values, i.e. all the values should lie within the specified tolerance viz, $a = \pm 1\%$, and thus the distribution model corresponds to a rectangular probability distribution specified in the GUM, hence the standard uncertainty values for the individual parameters are given by $a/\sqrt{3}$. To fully comply with the assessment of uncertainty it would be necessary to consider all the possible sources of uncertainty contributing to the measurements including those due to uncertainties in the devices used in the calibration chain, i.e. the force proving devices and the extensometer calibrators. In practice, such sources of error are second order effects and for the purposes of this document a simplified approach will be adopted using the concepts outlined in the GUM. The combined uncertainty of the material independent parameters for R_{eH} , R_{eL} , R_m and A is $\sqrt{0,33+0,33} = \pm 0,81\%$, and for R_p is $\sqrt{0,33+0,33+0,33+0,33} = \pm 1,15\%$; using a root mean-squares summation approach. See footnote b of Table J.1.

J.3.2 Material dependent parameters

For room temperature tensile testing, the only tensile properties significantly dependent upon the materials response to the strain rate (or stress rate) control parameters are R_{eH} , R_{eL} and R_p . Tensile strength, R_m , can also be strain rate dependent, however in practice it is usually determined at a much higher strain rate than R_p and is generally relatively insensitive to variations in the rapid strain rates.

In principle, it will be necessary to determine any materials strain rate response before the total uncertainty budget can be calculated. Some limited data and the following examples may be used to estimate uncertainty for some classes of materials.

Typical example of data sets used to determine materials response over the strain rate range specified in EN 10002-1 is shown in Figures J.1 and J.2 and a summary of materials response for proof stress for a number of materials measured under strain rate control is given in Table J.2 Earlier data on a variety of steels measured under a set stress rate are given in the seminar paper [13].

Since the equivalent tolerances, a , are based on measured data, using a simple least mean squares fit to the data, it is necessary to decide what distribution model of the uncertainties is appropriate in accordance with the GUM. If it is assumed that the model is a normal distribution with upper and lower limits a_+ and a_- , such that the best estimate of the quantity is $(a_+ + a_-)/2$ and that there is a 2 out of 3 chance (i.e. a 67% probability) that the value of the quantity lies in the interval a_- to a_+ , then the uncertainty $U = a$.

NOTE If it was assumed that the probability was 50%, then $U = 1,48a$ (see [10]).

Table J.2 — Variation in room temperature proof strength over the strain rate range permitted in EN 10002- 1

Material	Nominal composition	$R_{p0,2}$	Proof strength Strain rate Response %	Equivalent tolerance ± %
		Mean value MPa		
Ferritic steel				
Pipe steel	Cr-Mo-V-Fe(bal)	680	0,1	0,05
Plate steel (S275)	C-Mn-Fe(bal)	315	1,8	0,9
Austenitic steel				
Stainless steel	17Cr, 11Ni-Fe(bal)	235	6,8	3,4
Nickel Base Alloys				
NiCr20Ti	18Cr, 5Fe, 2Co-Ni(bal)	325	2,8	1,4
NiCrCoTiAl 25-20	24Cr, 20Co, 3Ti, 1,5Mo, 1,5Al-Ni(bal)	790	1,9	0,95

J.3.3 Combined standard measurement uncertainty

The material dependent response of proof strength over the permitted strain rate range specified in the standard given in Table J.2 may be combined with the standard uncertainties derived from material independent parameters specified in Table J.1 to give the combined standard uncertainty, U_c , for the various materials indicated, as shown in Table J.3.

For the purpose of this analysis, the total value of the variation in proof strength over the strain rate range permitted in the standard has been halved and expressed as an equivalent tolerance, i.e. for stainless steel, the proof strength can vary by 6,8 % over the permitted strain rate range so it is equivalent to a tolerance of $\pm 3,4$ % which should be divided by $\sqrt{3}$, i.e. 1,963 and then added to the combined standard uncertainty of the material independent parameters using the root mean square method. Therefore for stainless steel, the combined standard uncertainty of $R_{p0,2}$ is given by :

$$U_c = \pm\sqrt{1,15^2 + 1,96^2} = \pm\sqrt{5,17} = \pm 2,3 \%$$

Table J.3 — Combined standard measurement uncertainty for room temperature proof strength determined in accordance with EN 10002-1

Material	Standard uncertainty from material independent parameters ± %	Material dependent standard uncertainty ± %	Combined standard uncertainty U_c ± %	Expanded uncertainty at 95% confidence ±%
<u>Ferritic Steel</u>				
Pipe steel	1,15	0,03	$\sqrt{1,33} = 1,15$ [7]	2,3
Plate steel	1,15	0,52	$\sqrt{1,59} = 1,26$ [8]	2,5
<u>Austenitic Steel</u>				
Stainless steel	1,15	1,96	$\sqrt{5,17} = 2,3$ [9]	4,6
<u>Nickel base alloys</u>				
Nimonic 75	1,15	0,81	$\sqrt{1,98} = 1,41$ [10]	2,8
Nimonic 101	1,15	0,55	$\sqrt{1,63} = 1,28$ [11]	2,7

J.3.4 Expanded uncertainty

In accordance with the ISO TAG4 Guide [7], the total expanded uncertainty is obtained by multiplying the combined standard uncertainties by a coverage function, k . For a 95 % level of confidence, $k=2$ and the corresponding expanded uncertainties are also listed in Table J.3.

J.4 Concluding remarks

A method of calculating the measurement uncertainty for room temperature tensile testing using an "Uncertainty Budget" concept has been outlined and examples given for a few materials where the material response to the testing parameters is known. It should be noted that the expanded uncertainties have been calculated using a simplified approach based on the GUM. In addition, there are other factors that can affect the measurement of tensile properties such as test piece bending, methods of gripping the test piece, or the testing machine control mode, i.e., extensometer control or load/crosshead control which may affect the measured tensile properties [14]. However since there is insufficient quantitative data available it is not possible to include their effects in uncertainty budgets at present. It should also be recognised that this uncertainty budget approach only gives an estimate of the uncertainty due to the measurement technique and does not make an allowance for the inherent scatter in experimental results attributable to material inhomogeneity.

Finally it should be appreciated that when suitable reference materials²⁾ become available they will offer a useful means of measuring the total measurement uncertainty on any given testing machine including the influence of grips, bending, etc, which at present have not been quantified.

Alternatively, it is recommended that "in-house" test pieces are tested for quality control purposes see [15].

J.5 Interlaboratory Scatter

An indication of the typical scatter in tensile test results for a variety of materials that have been observed during laboratory intercomparison exercises, which include both material scatter and measurement uncertainty are shown in Tables J.4 to J.7. The results for the **Reproducibility** are expressed in % calculated by multiplying the standard deviation by 2 and dividing the result by the mean, thereby giving values which represent the 95% confidence level, in accordance with the recommendations given in the GUM, and which may be directly compared with the Expanded Uncertainty values given above.

2) e.g Nimonic 75, a certified reference material for room temperature tensile testing, CRM661 which is available from the Institute for Reference Materials and Measurements, (IRMM), Joint Research Centre, Retieseweg, B-2440, Geel, Belgium. See [11].

Table J.4 — Yield Strengths (0,2% proof strengths or upper yield strengths) - Reproducibility from laboratory Intercomparison exercises

Material	Code	Yield strength MPa	Reproducibility $\pm U_E$ %	Reference
Aluminium	EC-H 19	158,4	8,1	[16]
	2024-T 351	362,9	3,0	[16]
Steel				
Low carbon, plate	HR3	228,6	8,2	[17]
Austenitic stainless	X2CrNi18-10	303,8	6,5	[17]
AISI 105	P245GH	402,4	8,9	[16]
Bar	S355	367,4	5,0	[17]
Ferritic stainless steel	X2Cr13	967,5	3,2	[16]
High strength	30NiCrMo16	1039,9	2,0	[17]
Austenitic stainless.	X2CrNiMo18-10	353,3	7,8	[17]
AISI 316	X5CrNiMo17-12-2	480,1	8,1	[16]
Nickel alloys				
INCONEL 600	NiCr15Fe8	268,3	4,4	[16]
Nimonic 75 (CRM661)	NiCr20Ti	298,1	4,0	[18]

Table J.5 — Tensile strengths, R_m - Reproducibility from laboratory intercomparison exercises

Material	Code	Tensile strength MPa	Reproducibility +/- U_E , %	Reference
Aluminium	EC-H 19	176,9	not reported	[16]
	2024-T 351	491,3	2,6	[16]
Steel				
Low Carbon, Plate	HR3	335,2	5,0	[17]
Austenitic stainless	X2CrNi18-10	594,0	3,0	[17]
AISI 105	P245GH	596,9	2,8	[16]
Bar	S355	552,4	2,0	[17]
Ferritic stainless steel	X2Cr13	1253	1,2	[16]
High strength	30NiCrMo16	1167,8	1,5	[17]
Austenitic stainless	X2CrNiMo18-10	622,5	3,0	[17]
AISI 316	X5CrNiMo17-12-2	694,6	2,4	[16]
Nickel Alloys				
INCONEL 600	NiCr15Fe8	695,9	1,4	[16]
Nimonic 75, (CRM661)	NiCr20Ti	749,6	1,9	[18]

Table J.6 — Reduction in area - Reproducibility from laboratory intercomparison exercises

Material	Code	Reduction in area, Z %	Reproducibility +/- U_E , %	Reference
Aluminium	EC-H 19	79,1	5,1	[16]
	2024-T 351	30,3	23,7	[16]
Steel				
AISI 105	P245GH	65,6	3,6	[16]
Bar	S355	71,4	2,7	[17]
Ferritic stainless steel	X2Cr13	50,5	15,6	[16]
High strength	30NiCrMo16	65,6	3,2	[17]
Austenitic stainless	X2CrNiMo18-10	77,9	5,6	[17]
AISI 316	X5CrNiMo17-12-2	71,5	4,5	[16]
Nickel alloys				
ICONEL 600	NiCr15Fe8	59,3	2,4	[16]
Nimonic 75, (CRM661)	NiCr20Ti	59,0	8,8	[18]

Table J.7 — Elongation after fracture - Reproducibility from laboratory intercomparison exercises

Material	Code	Elongation at fracture, A %	Reproducibility +/- U_E , %	Reference
Aluminium	EC-H 19	14,6	9,1	[16]
	2024-T 351	18,0	18,9	[16]
Steel				
AISI 105	P245GH	25,6	10,1	[16]
Bar	S355	31,4	14	[17]
Ferritic stainless steel	X2Cr13	12,4	15,5	[16]
High strength	30NiCrMo16	16,7	13,2	[17]
Austenitic stainless	X2CrNiMo18-10	51,9	13,6	[17]
AISI 316	X5CrNiMo17-12-2	35,9	14,9	[16]
Nickel alloys				
ICONEL 600	NiCr15Fe8	41,6	7,7	[16]
Nimonic 75, (CRM661)	NiCr20Ti	41,0	3,3	[18]

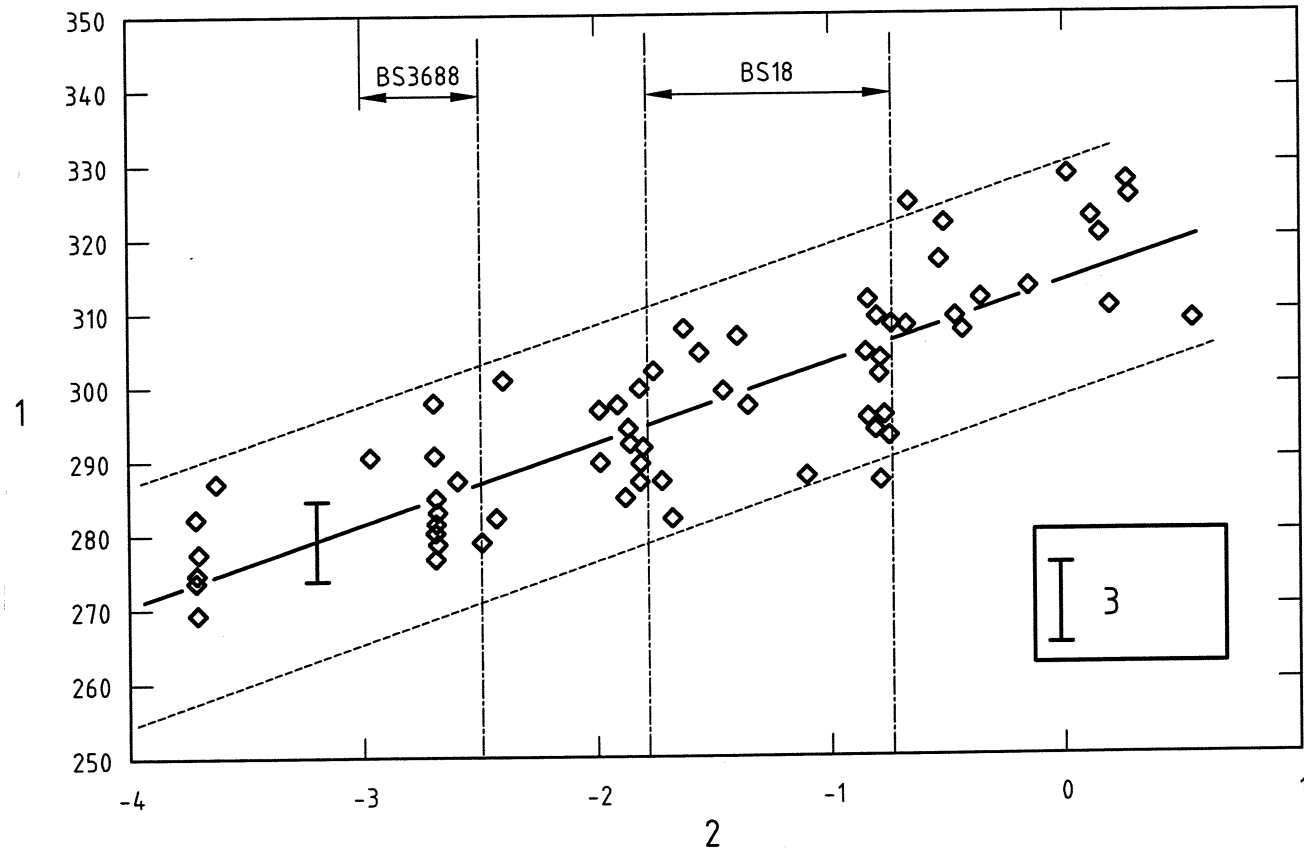

Key

- 1 Lower yield strength (MPa)
- 2 lg10 plastic strain rate per minute
- 3 Maximum expected error in stress

Figure J.1 - Variation of lower yield strength (R_{eL}) at room temperature as a function of strain rate, for plate steel [16]

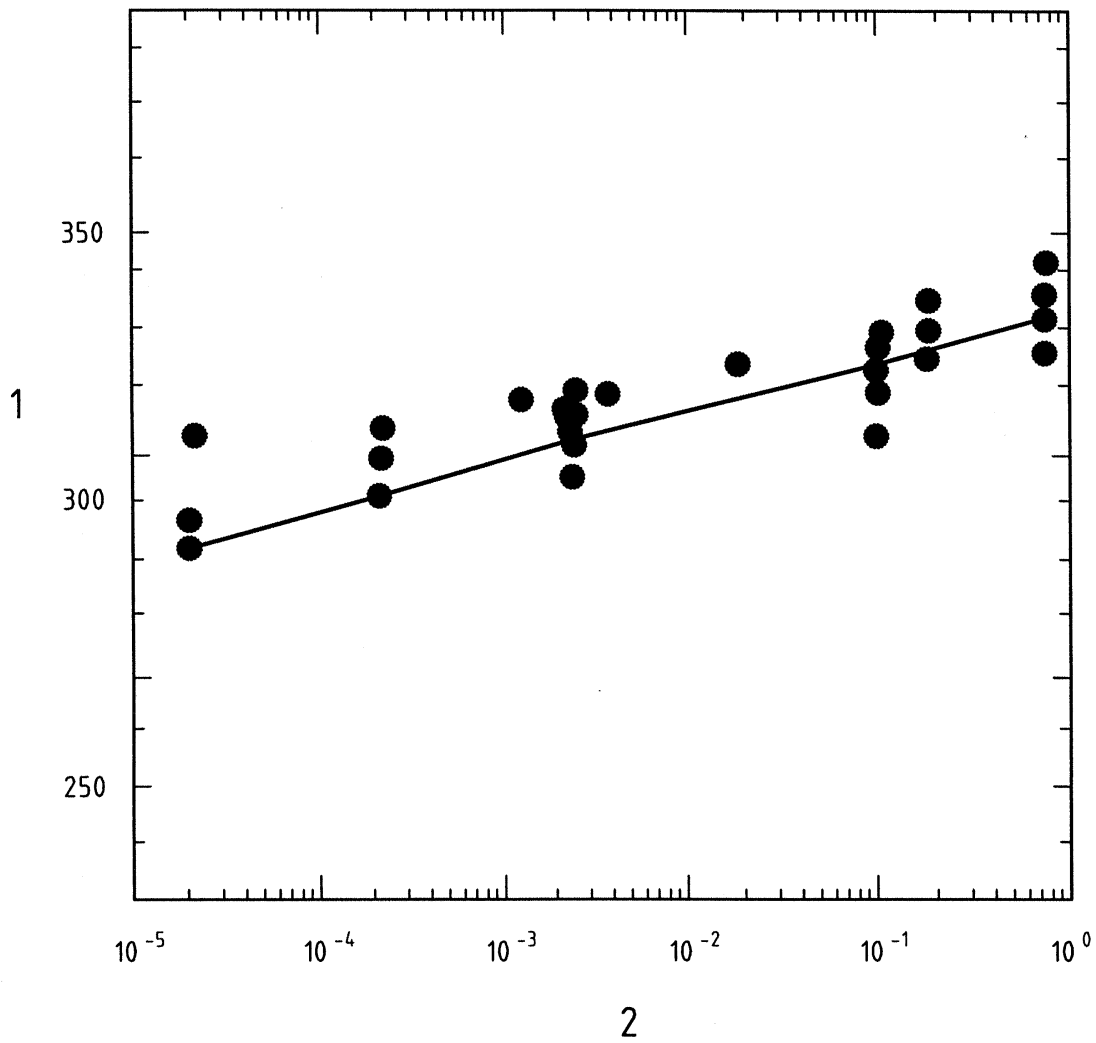
**Key**

- 1 0,2% proof stress, MPa
- 2 Strain/min

Figure J.2 - Tensile test data at 22 °C for NiCr20Ti

Bibliography

- [1] H. M. SONNE, B. HESSE "Determination of Young's Modulus on steel sheet by computerised tensile test - Comparison of different evaluation concepts" Tagung "Werkstoffprüfung 1993" DVM-Tagungsband
- [2] G.D. DEAN, M.S. LOVEDAY, P.M. COOPER, B.E. READ, B. ROEBUCK and R. MORREL "Aspects of modulus measurement" Chapt 8, pp 150-209 in "Materials Metrology and Standards for standard Performance" Ed : B.G. DYSON, M.S. LOVEDAY and M.G. GEE, Pub Chapman and Hall. 1995
- [3] B. ROEBUCK, J.D. LORD, P.M. COPPER and L.N. Mc CARTNEY "Data Acquisition and Analysis of Tensile Properties for MMC" ASTM journal of testing and Evaluation (JTEVA) 22(1) 63-69
- [4] ISO/TTA 2(1996) Tensile tests for Discontinuously Reinforced Metal Matrix composites at Ambient Temperatures
- [5] M.S. LOVEDAY (1992) "Towards a tensile reference material", Chapter 7, pp 111 - 153 in Harmonisation of Testing Practice for High Temperature Materials. Ed M.S. LOVEDAY and T.B. GIBBONS. Pub Chapman and Hall (formerly published by Elsevier Applied Science)
- [6] ISO 6892:1998 "Metallic materials – Tensile testing at ambient temperature"
- [7] ISO (TAG4)(1993) 'Guide to the expression of uncertainty in measurement.' BIMP/IEC/IFCC/ISO/ IUPAC/IUPAP/OIML
- [8] NIS 80. "Guide to the expression of uncertainty in testing". Pub. NAMAS. 1994.
- [9] NIS 3003. The Expression of Uncertainty and Confidence in Measurement. Pub. NAMAS. 1995.
- [10] B.N. TAYLOR and C.E. KUYATT (1993). Guidelines for Evaluating and Expressing the Uncertainty of NIST Measurement Results. NIST Technical Note 1297.
- [11] M. S. LOVEDAY "Room temperature tensile testing : a method for estimating uncertainty of measurement", NPL Measurement note CMMT (MN) 048, ISSN 1366-4506
- [12] EN 10291 "Metallic materials – Uniaxial creep testing in tension – Method of test"
- [13] R.F. JOHNSON and J.D. MURRAY (1966) "The effect of rate of straining on the 0.2 % proof stress and lower yield stress of steel", Symposium on High Temperature Performance of Steels", Eastbourne 1966, Pub Iron & Steel Institute, 1967
- [14] T.G.F GRAY and J. SHARP (1988) "Influence of machine type and strain-rate interaction in tensile testing" ASTM Symposium on Precision of Mechanical Tests, STP 1025
- [15] H.M. SONNE, G. KNAUF, J. SCHMIDT-ZINGES, Überlegungen zur Überprüfung von Zugprüfmaschinen mittels Referenzmaterial Deutscher Verband für Materialforschung und Prüfung (DVM) ISSN 0941-5300, Tagungsband Bad Nauheim 1996.
- [16] ASTM Research Report RR E - 28 1004 (March 1994) - Round Robin Results of Interlaboratory Tensile Tests
- [17] L. ROESCH, N. COUE, J. VITALI, M. DI FANT - Results of an Interlaboratory Test Programme on Room Temperature Tensile Properties - Standard Deviation of the Measured Values - IRSID Report N. DT. 93310 (July 1993)
- [18] M.S. LOVEDAY. (1999) "Certification of a Room Temperature Tensile Reference Material" EU Report (to be published)

BSI — British Standards Institution

BSI is the independent national body responsible for preparing British Standards. It presents the UK view on standards in Europe and at the international level. It is incorporated by Royal Charter.

Revisions

British Standards are updated by amendment or revision. Users of British Standards should make sure that they possess the latest amendments or editions.

It is the constant aim of BSI to improve the quality of our products and services. We would be grateful if anyone finding an inaccuracy or ambiguity while using this British Standard would inform the Secretary of the technical committee responsible, the identity of which can be found on the inside front cover. Tel: 020 8996 9000. Fax: 020 8996 7400.

BSI offers members an individual updating service called PLUS which ensures that subscribers automatically receive the latest editions of standards.

Buying standards

Orders for all BSI, international and foreign standards publications should be addressed to Customer Services. Tel: 020 8996 9001. Fax: 020 8996 7001. Standards are also available from the BSI website at <http://www.bsi-global.com>.

In response to orders for international standards, it is BSI policy to supply the BSI implementation of those that have been published as British Standards, unless otherwise requested.

Information on standards

BSI provides a wide range of information on national, European and international standards through its Library and its Technical Help to Exporters Service. Various BSI electronic information services are also available which give details on all its products and services. Contact the Information Centre. Tel: 020 8996 7111. Fax: 020 8996 7048.

Subscribing members of BSI are kept up to date with standards developments and receive substantial discounts on the purchase price of standards. For details of these and other benefits contact Membership Administration. Tel: 020 8996 7002. Fax: 020 8996 7001. Further information about BSI is available on the BSI website at <http://www.bsi-global.com>.

Copyright

Copyright subsists in all BSI publications. BSI also holds the copyright, in the UK, of the publications of the international standardization bodies. Except as permitted under the Copyright, Designs and Patents Act 1988 no extract may be reproduced, stored in a retrieval system or transmitted in any form or by any means – electronic, photocopying, recording or otherwise – without prior written permission from BSI.

This does not preclude the free use, in the course of implementing the standard, of necessary details such as symbols, and size, type or grade designations. If these details are to be used for any other purpose than implementation then the prior written permission of BSI must be obtained.

If permission is granted, the terms may include royalty payments or a licensing agreement. Details and advice can be obtained from the Copyright Manager. Tel: 020 8996 7070.