

**Aerospace series —
Connectors, optical,
rectangular, modular,
multicontact,
1,25 diameter ferrule,
with removable
alignment sleeve
holder —**

**Part 101: Optical contact for cable
EN 4641-100 — Operating temperatures
between -65 °C and 125 °C — Product
standard**

ICS 49.060

National foreword

This British Standard is the UK implementation of EN 4639-101:2007.

The UK participation in its preparation was entrusted by Technical Committee ACE/6, Aerospace avionic electrical and fibre optic technology, to Panel ACE/6/-/3, Aerospace — Connectors.

A list of organizations represented on this committee can be obtained on request to its secretary.

This publication does not purport to include all the necessary provisions of a contract. Users are responsible for its correct application.

Compliance with a British Standard cannot confer immunity from legal obligations.

This British Standard was published under the authority of the Standards Policy and Strategy Committee on 29 February 2008

© BSI 2008

ISBN 978 0 580 56485 7

Amendments/corrigenda issued since publication

Date	Comments

ICS 49.060

English Version

Aerospace series - Connectors, optical, rectangular, modular, multicontact, 1,25 diameter ferrule, with removable alignment sleeve holder - Part 101: Optical contact for cable EN 4641-100 - Operating temperatures between - 65 °C and 125 °C - Product standard

Série aérospatiale - Connecteurs optiques rectangulaires, modulaires multicontacts, fêrulle 1,25, équipés d'un porte sleeve démontable - Partie 101 : Contact optique pour câble EN 4641-100 - Températures de fonctionnement comprises entre - 65 °C et 125 °C - Norme de produit

Luft- und Raumfahrt - Optischer Rechtecksteckverbinder, modular, Mehrfachkontakt, Ferrulendurchmesser 1,25 mm, demontierbarer Zentrierhülsenhafter - Teil 101: Optische Kontakt für EN 4641-100 Kabel - Betriebstemperaturen zwischen - 65 °C und 125 °C - Produktnorm

This European Standard was approved by CEN on 21 June 2007.

CEN members are bound to comply with the CEN/CENELEC Internal Regulations which stipulate the conditions for giving this European Standard the status of a national standard without any alteration. Up-to-date lists and bibliographical references concerning such national standards may be obtained on application to the CEN Management Centre or to any CEN member.

This European Standard exists in three official versions (English, French, German). A version in any other language made by translation under the responsibility of a CEN member into its own language and notified to the CEN Management Centre has the same status as the official versions.

CEN members are the national standards bodies of Austria, Belgium, Bulgaria, Cyprus, Czech Republic, Denmark, Estonia, Finland, France, Germany, Greece, Hungary, Iceland, Ireland, Italy, Latvia, Lithuania, Luxembourg, Malta, Netherlands, Norway, Poland, Portugal, Romania, Slovakia, Slovenia, Spain, Sweden, Switzerland and United Kingdom.



EUROPEAN COMMITTEE FOR STANDARDIZATION
COMITÉ EUROPÉEN DE NORMALISATION
EUROPÄISCHES KOMITEE FÜR NORMUNG

Management Centre: rue de Stassart, 36 B-1050 Brussels

Contents

Page

Foreword.....	3
1 Scope	4
2 Normative references	4
3 Fibre optic contact designation and dimensions.....	4
3.1 Contact designation	4
3.2 Contact dimensions.....	4
3.3 Cable designation	6
4 Technical specification	6
5 Tests according to EN 2591 series	6
6 Assembly process instructions	7
6.1 Cleaning instructions	7
6.2 Tooling	7
6.3 Termination instructions.....	7
7 Designation	8

Foreword

This document (EN 4639-101:2007) has been prepared by the Aerospace and Defence Industries Association of Europe - Standardization (ASD-STAN).

After enquiries and votes carried out in accordance with the rules of this Association, this Standard has received the approval of the National Associations and the Official Services of the member countries of ASD, prior to its presentation to CEN.

This European Standard shall be given the status of a national standard, either by publication of an identical text or by endorsement, at the latest by June 2008, and conflicting national standards shall be withdrawn at the latest by June 2008.

Attention is drawn to the possibility that some of the elements of this document may be the subject of patent rights. CEN [and/or CENELEC] shall not be held responsible for identifying any or all such patent rights.

According to the CEN/CENELEC Internal Regulations, the national standards organizations of the following countries are bound to implement this European Standard: Austria, Belgium, Bulgaria, Cyprus, Czech Republic, Denmark, Estonia, Finland, France, Germany, Greece, Hungary, Iceland, Ireland, Italy, Latvia, Lithuania, Luxembourg, Malta, Netherlands, Norway, Poland, Portugal, Romania, Slovakia, Slovenia, Spain, Sweden, Switzerland and the United Kingdom.

1 Scope

This standard defines the performance and dimensions of optical physical contact for EN 4641-100 cable specification.

2 Normative references

The following referenced documents are indispensable for the application of this document. For dated references, only the edition cited applies. For undated references, the latest edition of the referenced document (including any amendments) applies.

EN 2591-*, *Aerospace series — Elements of electrical and optical connection — Test methods.*

EN 4639-001, *Aerospace series — Connectors, optical, rectangular, modular, multicontact, 1,25 diameter ferrule, with removable alignment sleeve holder — Part 001: Technical specification.*

EN 4639-002, *Aerospace series — Connectors, optical, rectangular, modular, multicontact, 1,25 diameter ferrule, with removable alignment sleeve holder — Part 002: List of product standards.*

EN 4641-100, *Aerospace series — Cable optical — 125 µm diameter cladding — Part 100: Outer diameter 1,8 mm, tight structure — Product standard.* ¹⁾

MIL-I-81969/14, *Installing and removal tools, connector electrical contact, type III, class 2, composition B.* ²⁾

TR 4647, *Aerospace series — Fibres and cables, optical aircraft use — Technical Report — Termination procedure for EN 4639 10X contact.* ¹⁾

3 Fibre optic contact designation and dimensions

3.1 Contact designation

See Table 1.

Table 1

Contact designation	Contact type	Cable structure type
Fibre optic contact for tight structure cable	MT	EN 4641-100

3.2 Contact dimensions

Dimensions and tolerances are in millimetres, see Figure 1.

* All parts quoted in this standard.

1) In preparation at the date of publication of this standard.

2) Published by: Department of Defense (DOD), the Pentagon, Washington D.C. 20301 USA.

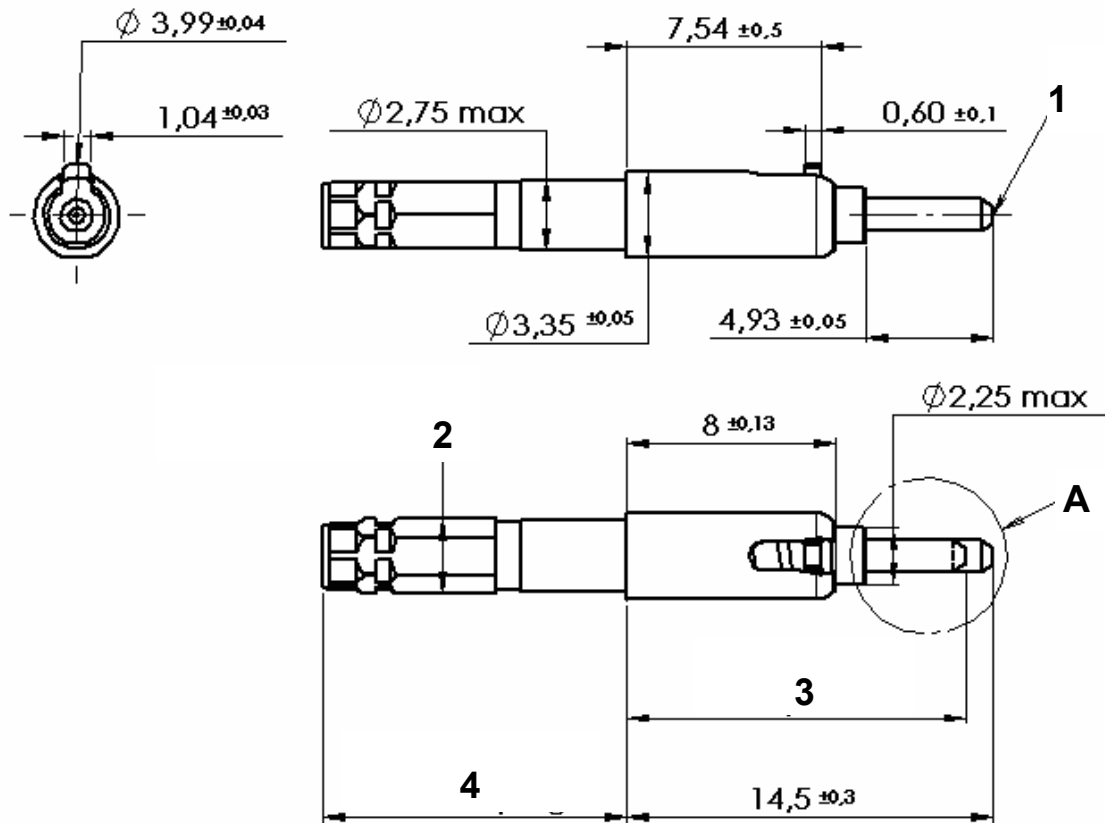

Spring force when connector is mated:
 Typical: 5,65 N (minimum 4,6 N, maximum 6,7 N)

View A
 Multimode ferrule for 125 µm fibre

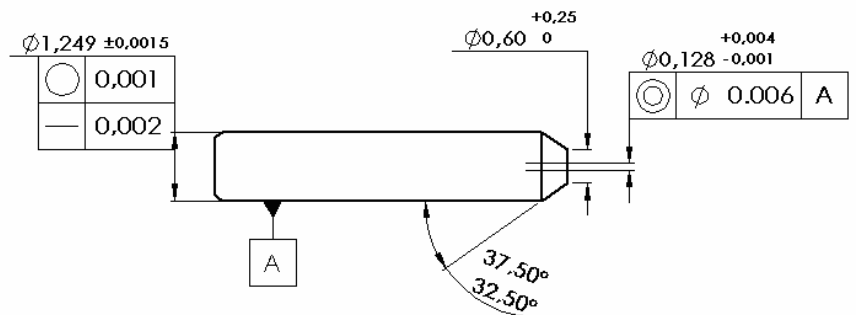

Key

- 1 Optical reference plane
- 2 \varnothing 2,95 max. after crimping
- 3 13,15 max. – Back position
- 4 12,3 max. – After crimping – Free position

Figure 1

3.3 Cable designation

Specified in EN 4641-100.

4 Technical specification

This component is qualified as part of a complete connector assembly when tested according to the qualification requirements of EN 4639-001 and the applicable product standards.

5 Tests according to EN 2591-100

The tests of EN 2591-100, applicable in the context of this standard as well as the details necessary for implementing them and for inspecting connector characteristics, are given in Table 2.

Environmental tests are specified in EN 4639-001.

Table 2

EN 2591-	Test	Details
6301	Endurance at temperature	1 000 hours at 125 °C
301	Endurance at temperature	Not applicable
304	Damp heat steady state	Temperature of 40 °C and 93 % of humidity
6305	Rapid change of temperature	10 cycles, $T_A = 125\text{ °C}$, $T_B = -65\text{ °C}$
6307	Salt mist	Mated connectors – Severity according to environmental class of the connector
309	Dry heat	Not applicable
310	Cold	Not applicable
311	Low air pressure	Not applicable
313	Driving rain (artificial)	Not applicable
6316	Ozone resistance	Not applicable
320	Simulated solar radiation at ground level	Not applicable
6401	Acceleration steady state	Not applicable
6405	Axial load	100 N maintained for 1 minute, 3 cycles
6406	Mechanical endurance	500 mating/unmating cycles
407	Durability of contact retention system and seals (maintenance aging)	Applicable
601	Insertion loss	0,7 dB max. during and after tests
602	Variation of attenuation and optical discontinuity	Method A, IL maximum = 0,7 dB
604	Cleaning capability of optical face	Applicable
605	Return loss	RL < - 21 dB
607	Immunity to ambient light coupling	Not applicable
608	Nuclear radiation	Not applicable
609	Effectiveness of cable attachment – Cable cyclic flexing	100 cycles at load of 40 N
610	Effectiveness of cable attachment – Cable pulling	Method B, 68 N tensile load, 1 minute, 3 pulls
611	Effectiveness of cable attachment – Cable torsion	100 cycles at load of 40 N
612	Effectiveness of cable attachment – Cable axial compression	Compression force of 10 N for 2 minutes

EN 2591-	Test	Details
613	Impact test	Severity: light
615	Connection integrity at temperature	Not applicable
617	Temperature cycling	10 cycles, $T_A = 125\text{ °C}$, $T_B = -65\text{ °C}$

6 Assembly process instructions

6.1 Cleaning instructions

This fibre optic connector provides an easy access to the optical faces and sleeves for cleaning.

Cleaning operation can be performed as follows:

1. Unmate the pair of connectors.
2. Remove the sleeve holder (From the female insert).
3. Use cleaning stick and pipe with ethylic alcohol (or equivalent) to clean the front face of the optical contact and the inside of the sleeve without removing the contacts from their cavities.
4. Use dry clean air can for drying.
5. Inspect optical face
6. Install the sleeve holder (From the female insert).
7. Mate the pair of connectors.

See TR 4647 for details.

6.2 Tooling

For insertion and extraction of the optical contact use the standard tool as per MIL-I-81969/14-3 standard (P/N for size 16).

6.3 Termination instructions

General termination operation:

1. Pass the cable through the crimping ferrule
2. Strip the cable down to the 125 μm fibre
3. Inject epoxy glue with adapted syringe inside the optical ferrule from the front side.
4. Insert the optical contact onto the fibre and the cable.
5. Slide and crimp the rear ferrule onto the body contact, the cable and its strength members.
6. Cure the epoxy glue with an appropriate cure oven.
7. Cleave the fibre and polish the front face of the optical contact.
8. Inspection and control.

See TR 4647 for details.

7 Designation

EXAMPLE

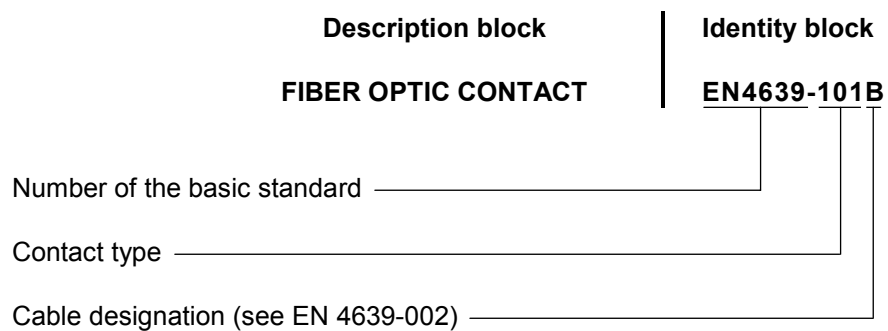

BSI — British Standards Institution

BSI is the independent national body responsible for preparing British Standards. It presents the UK view on standards in Europe and at the international level. It is incorporated by Royal Charter.

Revisions

British Standards are updated by amendment or revision. Users of British Standards should make sure that they possess the latest amendments or editions.

It is the constant aim of BSI to improve the quality of our products and services. We would be grateful if anyone finding an inaccuracy or ambiguity while using this British Standard would inform the Secretary of the technical committee responsible, the identity of which can be found on the inside front cover.
Tel: +44 (0)20 8996 9000. Fax: +44 (0)20 8996 7400.

BSI offers members an individual updating service called PLUS which ensures that subscribers automatically receive the latest editions of standards.

Buying standards

Orders for all BSI, international and foreign standards publications should be addressed to Customer Services. Tel: +44 (0)20 8996 9001.
Fax: +44 (0)20 8996 7001. Email: orders@bsi-global.com. Standards are also available from the BSI website at <http://www.bsi-global.com>.

In response to orders for international standards, it is BSI policy to supply the BSI implementation of those that have been published as British Standards, unless otherwise requested.

Information on standards

BSI provides a wide range of information on national, European and international standards through its Library and its Technical Help to Exporters Service. Various BSI electronic information services are also available which give details on all its products and services. Contact the Information Centre.
Tel: +44 (0)20 8996 7111. Fax: +44 (0)20 8996 7048. Email: info@bsi-global.com.

Subscribing members of BSI are kept up to date with standards developments and receive substantial discounts on the purchase price of standards. For details of these and other benefits contact Membership Administration.
Tel: +44 (0)20 8996 7002. Fax: +44 (0)20 8996 7001.
Email: membership@bsi-global.com.

Information regarding online access to British Standards via British Standards Online can be found at <http://www.bsi-global.com/bsonline>.

Further information about BSI is available on the BSI website at <http://www.bsi-global.com>.

Copyright

Copyright subsists in all BSI publications. BSI also holds the copyright, in the UK, of the publications of the international standardization bodies. Except as permitted under the Copyright, Designs and Patents Act 1988 no extract may be reproduced, stored in a retrieval system or transmitted in any form or by any means – electronic, photocopying, recording or otherwise – without prior written permission from BSI.

This does not preclude the free use, in the course of implementing the standard, of necessary details such as symbols, and size, type or grade designations. If these details are to be used for any other purpose than implementation then the prior written permission of BSI must be obtained.

Details and advice can be obtained from the Copyright & Licensing Manager.
Tel: +44 (0)20 8996 7070. Fax: +44 (0)20 8996 7553.
Email: copyright@bsi-global.com.