

**Aerospace series —
Screws, 100°
countersunk head,
six lobe recess, short
thread, in titanium
alloy TI-P64001, with
aluminium
pigmented coating
— Classification:
1 100 MPa (at
ambient
temperature) / 315 °C**

ICS 49.030.20

National foreword

This British Standard is the UK implementation of EN 4636:2009.

The UK participation in its preparation was entrusted to Technical Committee ACE/12, Aerospace fasteners and fastening systems.

A list of organizations represented on this committee can be obtained on request to its secretary.

This publication does not purport to include all the necessary provisions of a contract. Users are responsible for its correct application.

Compliance with a British Standard cannot confer immunity from legal obligations.

This British Standard was published under the authority of the Standards Policy and Strategy Committee on 30 June 2009.

© BSI 2009

ISBN 978 0 580 56459 8

Amendments/corrigenda issued since publication

Date	Comments

EUROPEAN STANDARD

EN 4636

NORME EUROPÉENNE

EUROPÄISCHE NORM

June 2009

ICS 49.030.10

English Version

Aerospace series - Screws, 100° countersunk head, six lobe recess, short thread, in titanium alloy TI-P64001, with aluminium pigmented coating - Classification: 1 100 MPa (at ambient temperature) / 315 °C

Série aérospatiale - Vis, 100° à tête fraisée, à filetage court, à empreinte six lobes, en alliage de titane TI-P64001, avec revêtement aluminé-organique - Classification: 1 100 MPa (à température ambiante) / 315 °C

Luft- und Raumfahrt - 100° Senkschrauben, kurzes Gewinde, Sechsbogenzahn, aus Titanlegierung TI-P64001, mit aluminium pigmentierter Beschichtung - Klasse: 1 100 MPa (bei Raumtemperatur) / 315 °C

This European Standard was approved by CEN on 20 March 2009.

CEN members are bound to comply with the CEN/CENELEC Internal Regulations which stipulate the conditions for giving this European Standard the status of a national standard without any alteration. Up-to-date lists and bibliographical references concerning such national standards may be obtained on application to the CEN Management Centre or to any CEN member.

This European Standard exists in three official versions (English, French, German). A version in any other language made by translation under the responsibility of a CEN member into its own language and notified to the CEN Management Centre has the same status as the official versions.

CEN members are the national standards bodies of Austria, Belgium, Bulgaria, Cyprus, Czech Republic, Denmark, Estonia, Finland, France, Germany, Greece, Hungary, Iceland, Ireland, Italy, Latvia, Lithuania, Luxembourg, Malta, Netherlands, Norway, Poland, Portugal, Romania, Slovakia, Slovenia, Spain, Sweden, Switzerland and United Kingdom.



EUROPEAN COMMITTEE FOR STANDARDIZATION
COMITÉ EUROPÉEN DE NORMALISATION
EUROPÄISCHES KOMITEE FÜR NORMUNG

Management Centre: Avenue Marnix 17, B-1000 Brussels

Contents

Page

Foreword.....	3
1 Scope	4
2 Normative references	4
3 Required characteristics	4
3.1 Configuration – Dimensions – Tolerances – Masses.....	4
3.2 Materials	4
3.3 Surface treatment	5
3.4 Tolerances of form and position	5
4 Designation	6
5 Marking	7
6 Technical specification	7
6.1 General.....	7
6.2 Approval of manufacturers	7
6.3 Qualification of bolts	7
6.4 Requirement deleted	7

Foreword

This document (EN 4636:2009) has been prepared by the Aerospace and Defence Industries Association of Europe - Standardization (ASD-STAN).

After enquiries and votes carried out in accordance with the rules of this Association, this Standard has received the approval of the National Associations and the Official Services of the member countries of ASD, prior to its presentation to CEN.

This European Standard shall be given the status of a national standard, either by publication of an identical text or by endorsement, at the latest by December 2009, and conflicting national standards shall be withdrawn at the latest by December 2009.

Attention is drawn to the possibility that some of the elements of this document may be the subject of patent rights. CEN [and/or CENELEC] shall not be held responsible for identifying any or all such patent rights.

According to the CEN/CENELEC Internal Regulations, the national standards organizations of the following countries are bound to implement this European Standard: Austria, Belgium, Bulgaria, Cyprus, Czech Republic, Denmark, Estonia, Finland, France, Germany, Greece, Hungary, Iceland, Ireland, Italy, Latvia, Lithuania, Luxembourg, Malta, Netherlands, Norway, Poland, Portugal, Romania, Slovakia, Slovenia, Spain, Sweden, Switzerland and the United Kingdom.

1 Scope

This standard specifies the characteristics of screws with 100° countersunk head, with six lobe recess, short thread, in titanium alloy TI-P64001, aluminium pigmented coating, for aerospace applications.

2 Normative references

The following referenced documents are indispensable for the application of this document. For dated references, only the edition cited applies. For undated references, the latest edition of the referenced document (including any amendments) applies.

ISO 3353-1, *Aerospace — Lead and runout threads — Part 1: Rolled external threads.*

ISO 5855-2, *Aerospace — MJ threads — Part 2: Limit dimensions for bolts and nuts.*

ISO 7913, *Aerospace — Bolts and screws, metric — Tolerances of form and position.*

ISO 9152, *Aerospace — Bolts, with MJ threads, in titanium alloys, strength class 1 100 MPa — Procurement specification.*

EN 2424, *Aerospace series — Marking of aerospace products.*

EN 3813, *Aerospace series — Titanium alloy TI-P64001 — Annealed — Bar and wire for forged fasteners — $D_e \leq 25$ mm.*¹⁾

EN 3911, *Aerospace series — Six lobe recess — Geometrical definition.*¹⁾

EN 4473, *Aerospace series — Aluminium pigmented coatings — Technical specification.*¹⁾

EN 9100, *Aerospace series — Quality management systems — Requirements (based on ISO 9001:2000) and Quality systems — Model for quality assurance in design, development, production, installation and servicing (based on ISO 9001:1994).*

EN 9133, *Aerospace series — Quality management systems — Qualification procedure for aerospace standard parts.*

3 Required characteristics

3.1 Configuration – Dimensions – Tolerances – Masses

See Figure 1 and Table 1.

Dimensions and tolerances are in millimetres and apply after surface treatment.

3.2 Materials

EN 3813

1) Published as ASD Prestandard at the date of publication of this standard.

3.3 Surface treatment

EN 4473

3.4 Tolerances of form and position

ISO 7913

$\sqrt{3.2}$ $\left[\sqrt{0.8} \right]$ Values in micrometers apply prior to surface treatment.

Break sharp edges 0,1 to 0,4.

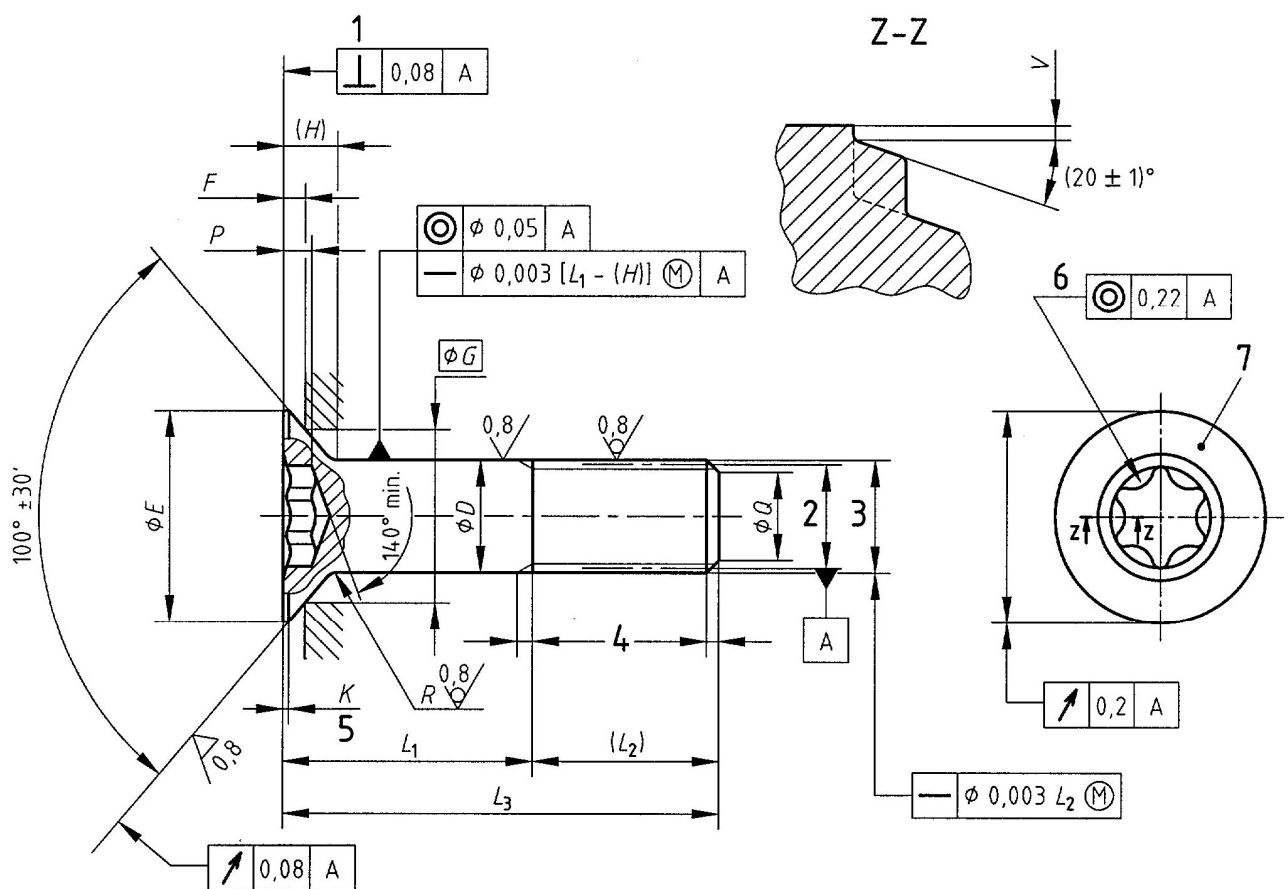

Key

- 1 Not concave
- 2 Pitch diameter
- 3 Thread
- 4 Conforms to ISO 3353-1
- 5 The rounded angle accepted
- 6 Six lobe recess conforms to EN 3911
- 7 Marking

Figure 1

Table 1

Code	Thread Designation	<i>D</i>	$\varnothing E$	<i>F</i>	<i>G</i>	<i>H</i>	<i>K</i>	$L_1 \pm 0,2$		<i>L</i> ₂
		h12	min.	$\begin{matrix} 0 \\ -0,08 \end{matrix}$	Ref.	Ref.	min.	Length code	min.	
030	MJ3×0,5-4h6h	3	5,6	0,63	4,50	1,3	0,06	003 to 030	3	6
040	MJ4×0,7-4h6h	4	7,5	0,93	5,78	1,7	0,08	003 to 040	3	7,5
050	MJ5×0,8-4h6h	5	9,5	0,96	7,71	2,1	0,1	004 to 050	4	9
060	MJ6×1-4h6h	6	11,5	1,26	9,00	2,6	0,1	005 to 060	5	10
080	MJ8×1-4h6h	8	15,4	1,60	12,21	3,4	0,1	006 to 080	6	11,5
100	MJ10×1,25-4h6h	10	19,3	1,93	15,43	4,2	0,1	008 to 100	8	14,5
120	MJ12×1,25-4h6h	12	23	2,53	18,00	5	0,1	010 to 100	10	16

Code	Thread ^a Designation	<i>P</i>		<i>Q</i>		<i>R</i>		<i>V</i> mm	Recess code ^b
		nom.	Tol.	nom.	Tol.	max.	min.		
030	MJ3×0,5-4h6h	0,8	0 -0,1	2,3	0 -0,5	0,4	0,2	0,13	EN3911-09
040	MJ4×0,7-4h6h	1		2,9					EN3911-15
050	MJ5×0,8-4h6h	1,1	3,8	EN3911-20					
060	MJ6×1-4h6h	1,5	0 -0,2	4,5	±0,5	0,5	0,3	0,25	EN3911-27
080	MJ8×1-4h6h	2	0 -0,3	6,2		0,7	0,5		EN3911-40
100	MJ10×1,25-4h6h	2,3	0 -0,5	7,9		0,7	0,5		EN3911-45
120	MJ12×1,25-4h6h	2,8		9,9		0,8	0,6		EN3911-50

^aConforms to ISO 5855-2.

^bSee EN 3911.

4 Designation

EXAMPLE

Description block

Identity block

SCREW

EN4636-040003

Number of this standard

Diameter code (see Table 1)

Length code (see Table 1)

NOTE If necessary, the code I9005 shall be placed between the description block and the identity block.

5 Marking

See Table 2 and Figure 1.

Table 2

Diameter code	EN 2424 Style
030 to 050	F
060 to 120	C + MJ

6 Technical specification

6.1 General

ISO 9152, with the following modifications

6.2 Approval of manufacturers

EN 9100

6.3 Qualification of bolts

EN 9133

6.4 Requirement deleted

Double shear strength

BSI - British Standards Institution

BSI is the independent national body responsible for preparing British Standards. It presents the UK view on standards in Europe and at the international level. It is incorporated by Royal Charter.

Revisions

British Standards are updated by amendment or revision. Users of British Standards should make sure that they possess the latest amendments or editions.

It is the constant aim of BSI to improve the quality of our products and services. We would be grateful if anyone finding an inaccuracy or ambiguity while using this British Standard would inform the Secretary of the technical committee responsible, the identity of which can be found on the inside front cover. Tel: +44 (0)20 8996 9000. Fax: +44 (0)20 8996 7400.

BSI offers members an individual updating service called PLUS which ensures that subscribers automatically receive the latest editions of standards.

Buying standards

Orders for all BSI, international and foreign standards publications should be addressed to Customer Services. Tel: +44 (0)20 8996 9001. Fax: +44 (0)20 8996 7001 Email: orders@bsigroup.com You may also buy directly using a debit/credit card from the BSI Shop on the Website <http://www.bsigroup.com/shop>

In response to orders for international standards, it is BSI policy to supply the BSI implementation of those that have been published as British Standards, unless otherwise requested.

Information on standards

BSI provides a wide range of information on national, European and international standards through its Library and its Technical Help to Exporters Service. Various BSI electronic information services are also available which give details on all its products and services. Contact Information Centre. Tel: +44 (0)20 8996 7111 Fax: +44 (0)20 8996 7048 Email: info@bsigroup.com

Subscribing members of BSI are kept up to date with standards developments and receive substantial discounts on the purchase price of standards. For details of these and other benefits contact Membership Administration. Tel: +44 (0)20 8996 7002 Fax: +44 (0)20 8996 7001 Email: membership@bsigroup.com

Information regarding online access to British Standards via British Standards Online can be found at <http://www.bsigroup.com/BSOL>

Further information about BSI is available on the BSI website at <http://www.bsigroup.com>.

Copyright

Copyright subsists in all BSI publications. BSI also holds the copyright, in the UK, of the publications of the international standardization bodies. Except as permitted under the Copyright, Designs and Patents Act 1988 no extract may be reproduced, stored in a retrieval system or transmitted in any form or by any means – electronic, photocopying, recording or otherwise – without prior written permission from BSI.

This does not preclude the free use, in the course of implementing the standard, of necessary details such as symbols, and size, type or grade designations. If these details are to be used for any other purpose than implementation then the prior written permission of BSI must be obtained.

Details and advice can be obtained from the Copyright and Licensing Manager. Tel: +44 (0)20 8996 7070 Email: copyright@bsigroup.com