

# Aerospace series — Inserts, MJ threads, self-locking, self-broaching keys — Technical specifications

ICS 49.030.30

## National foreword

This British Standard is the UK implementation of EN 4621:2010.

The UK participation in its preparation was entrusted to Technical Committee ACE/12, Aerospace fasteners and fastening systems.

A list of organizations represented on this committee can be obtained on request to its secretary.

This publication does not purport to include all the necessary provisions of a contract. Users are responsible for its correct application.

**Compliance with a British Standard cannot confer immunity from legal obligations.**

This British Standard was published under the authority of the Standards Policy and Strategy Committee on 30 April 2010

© BSI 2010

ISBN 978 0 580 69133 1

### Amendments/corrigenda issued since publication

Date	Comments

EUROPEAN STANDARD

**EN 4621**

NORME EUROPÉENNE

EUROPÄISCHE NORM

March 2010

ICS 49.030.30

English Version

**Aerospace series - Inserts, MJ threads, self-locking, self-broaching keys - Technical specification**

Série aéronautique - Douilles filetées, à filetages MJ, à freinage interne à clavettes auto-brochantes - Spécification technique

Luft- und Raumfahrt - Gewindeeinsätze, MJ-Gewinden, selbstsichernd mit selbstbräumenden Stiften - Technische Lieferbedingungen

This European Standard was approved by CEN on 9 January 2010.

CEN members are bound to comply with the CEN/CENELEC Internal Regulations which stipulate the conditions for giving this European Standard the status of a national standard without any alteration. Up-to-date lists and bibliographical references concerning such national standards may be obtained on application to the CEN Management Centre or to any CEN member.

This European Standard exists in three official versions (English, French, German). A version in any other language made by translation under the responsibility of a CEN member into its own language and notified to the CEN Management Centre has the same status as the official versions.

CEN members are the national standards bodies of Austria, Belgium, Bulgaria, Croatia, Cyprus, Czech Republic, Denmark, Estonia, Finland, France, Germany, Greece, Hungary, Iceland, Ireland, Italy, Latvia, Lithuania, Luxembourg, Malta, Netherlands, Norway, Poland, Portugal, Romania, Slovakia, Slovenia, Spain, Sweden, Switzerland and United Kingdom.



EUROPEAN COMMITTEE FOR STANDARDIZATION  
COMITÉ EUROPÉEN DE NORMALISATION  
EUROPÄISCHES KOMITEE FÜR NORMUNG

**Management Centre: Avenue Marnix 17, B-1000 Brussels**

© 2010 CEN All rights of exploitation in any form and by any means reserved worldwide for CEN national Members.

Ref. No. EN 4621:2010: E

## Contents

Page

Foreword.....	3
1 Scope .....	4
2 Normative references .....	4
3 Terms and definitions .....	4
4 Quality assurance .....	7
4.1 Qualification .....	7
4.2 Acceptance.....	7
4.2.1 Purpose.....	7
4.2.2 Conditions .....	7
4.2.3 Responsibility .....	7
4.2.4 Inspection and test report.....	7
5 Requirements.....	7
Annex A (normative) Definition of test block .....	18
Annex B (normative) Assembly for rotational resistance test .....	19
Annex C (normative) Axial tensile strength test .....	21
Annex D (normative) Assembly for reusability test.....	23
Annex E (normative) "GO" gauge for inspection of the position of the keys.....	25

## Foreword

This document (EN 4621:2010) has been prepared by the Aerospace and Defence Industries Association of Europe - Standardization (ASD-STAN).

After enquiries and votes carried out in accordance with the rules of this Association, this Standard has received the approval of the National Associations and the Official Services of the member countries of ASD, prior to its presentation to CEN.

This European Standard shall be given the status of a national standard, either by publication of an identical text or by endorsement, at the latest by September 2010, and conflicting national standards shall be withdrawn at the latest by September 2010.

Attention is drawn to the possibility that some of the elements of this document may be the subject of patent rights. CEN [and/or CENELEC] shall not be held responsible for identifying any or all such patent rights.

According to the CEN/CENELEC Internal Regulations, the national standards organizations of the following countries are bound to implement this European Standard: Austria, Belgium, Bulgaria, Croatia, Cyprus, Czech Republic, Denmark, Estonia, Finland, France, Germany, Greece, Hungary, Iceland, Ireland, Italy, Latvia, Lithuania, Luxembourg, Malta, Netherlands, Norway, Poland, Portugal, Romania, Slovakia, Slovenia, Spain, Sweden, Switzerland and the United Kingdom.

## 1 Scope

This standard specifies the characteristics, qualification and acceptance requirements for self-locking inserts, self-broaching keys with MJ threads, for aerospace applications.

It is applicable whenever referenced.

## 2 Normative references

The following referenced documents are indispensable for the application of this document. For dated references, only the edition cited applies. For undated references, the latest edition of the referenced document (including any amendments) applies.

EN 2638, *Aerospace series — Aluminium alloy 2024-T3 — Extruded bar and section —  $1,2\text{ mm} \leq (a \text{ or } D) \leq 150\text{ mm}$  — With coarse peripheral grain control*<sup>1)</sup>

EN 4619, *Aerospace series — Inserts, MJ threads, self-locking, with self-broaching keys — Installation and removal procedure*

EN 4620, *Aerospace series — Inserts, MJ threads, self-locking, with self-broaching keys — Design standard*

EN 9133, *Aerospace series — Quality management systems — Qualification procedure for aerospace standard parts*

ISO 2859-1:1999, *Sampling procedures for inspection by attributes — Part 1: Sampling schemes indexed by acceptance quality limit (AQL) for lot-by-lot inspection*

ISO 3452:1984, *Non-destructive testing — Penetrant inspection — General principles*

ISO 4288, *Geometrical Product Specifications (GPS) — Surface texture: Profile method — Rules and procedures for the assessment of surface texture*

ISO 5855-1, *Aerospace — MJ threads — Part 1: General requirements*

ISO 5855-2, *Aerospace — MJ threads — Part 2: Limit dimensions for bolts and nuts*

ASTM E 112-96, *Standard Test Methods for Determining Average Grain Size*<sup>2)</sup>

## 3 Terms and definitions

For the purposes of this document, the following terms and definitions apply.

### 3.1 batch

quantity of finished parts, of the same type and same diameter, produced from the same material obtained from the same melt, manufactured in the course of the same production cycle, following the same manufacturing route and having undergone all the relevant heat treatments and surface treatments

---

1) Published as ASD Prestandard at the date of publication of this standard.

2) Published by: American Society for Testing and Materials (ASTM), 1916, Race Street, Philadelphia, PA 19103, USA.

## 3.2 Surface discontinuities

### 3.2.1

#### **crack**

rupture in the material which may extend in any direction and which may be intercrystalline or transcrystalline in character

### 3.2.2

#### **seam**

open surface defect

### 3.2.3

#### **lap**

surface defect caused by folding over metal fins or sharp corners and then rolling or forging them into the surface

### 3.2.4

#### **inclusions**

metallic or non-metallic particles originating from the manufacturing process

NOTE These particles may be isolated or arranged in strings.

### 3.2.5

#### **test temperature**

ambient temperature, unless otherwise specified

### 3.2.6

#### **simple random sampling**

taking of  $n$  items from a population of  $N$  items in such a way that all possible combinations of  $n$  items have the same probability of being chosen

### 3.2.7

#### **critical defect**

defect that, according to judgement and experience, is likely to result in hazardous or unsafe conditions for individuals using, maintaining, or depending upon the considered product, or that is likely to prevent performance of the function of a major end item

### 3.2.8

#### **major defect**

defect other than critical, that is likely to result in a failure or to reduce materially the usability of the considered product for its intended purpose

### 3.2.9

#### **minor defect**

defect that is not likely to reduce materially the usability of the considered product for its intended purpose, or that is a departure from established specification having little bearing on the effective use or operation of this product

### 3.2.10

#### **sampling plan**

plan according to which one or more samples are taken in order to obtain information and possibly to reach a decision

**3.2.11**  
**limiting quality**

**LQ<sub>10</sub>**

in a sampling plan, quality limit which corresponds to a specified 10 % probability of acceptance

NOTE 1 It is the limiting lot quality characteristic that the consumer is willing to accept with a low probability that a lot of this quality would occur.

NOTE 2 For the purposes of this standard, the limiting quality quoted in Table 4 corresponds to a probability of acceptance of 10 %.

**3.2.12**  
**acceptance quality limit**

**AQL**

quality limit which in a sampling plan corresponds to a specified but relatively high probability of acceptance

NOTE It is the maximum percent defective (or the maximum number of defects per hundred units) that, for purposes of sampling inspection, can be considered satisfactory as a process average.

**3.2.13**  
**finished insert**

insert ready for use, inclusive of any possible treatments and/or surface coatings, as specified in the definition document

**3.2.14**

**definition document**

document specifying all the requirements for finished inserts

**3.2.15**  
**self-locking torque**

torque to be applied to the associated bolt to maintain movement of rotation in relation to the part, the assembly being under no axial load and the insert locking zone being completely engaged with the bolt (minimum protrusion of two pitches, including the end chamfer)

**3.2.16**  
**seating torque**

tightening torque to be applied to the insert or bolt to introduce or to increase the axial load in the assembly

**3.2.17**  
**unseating torque**

untightening torque to be applied to the insert or bolt to reduce or remove the axial load in the assembly

**3.2.18**  
**breakaway torque**

torque required to start unscrewing the insert or the bolt from the associated part, with the insert locking device still fully engaged on the bolt, but after the axial load in the assembly has been removed by unscrewing half a turn followed by a halt in rotational movement



## 4 Quality assurance

### 4.1 Qualification

EN 9133.

Qualification inspections and tests (requirements, methods, numbers of inserts with self-broaching keys) are specified in Table 1. They shall be carried out on:

- each type and diameter of inserts;
- 39 inserts selected from a single batch by simple random sampling.

The test programme may possibly be reduced, or the qualification be granted without inspection or testing.

Any such decision shall be based on the results obtained on similar types and diameters of inserts provided that the design and manufacturing conditions are identical.

Table 2 indicates the allocation of insert samples for the inspections and tests.

### 4.2 Acceptance

#### 4.2.1 Purpose

The purpose of acceptance inspections and tests is to check, as simply as possible, by a method representative of actual use conditions, with the uncertainty inherent to statistical sampling, that the inserts constituting the batch satisfy the requirements of this standard.

#### 4.2.2 Conditions

Acceptance inspections and tests (requirements, methods, numbers of inserts) are specified in Table 1. They shall be carried out on each batch inserts from the batch to be tested shall be selected by simple random sampling.

Each insert may be submitted to several inspections or tests.

If a more stringent inspection is deemed necessary, all or part of the qualification inspections and tests may be performed during the acceptance inspections and tests. In this case, the number of inserts submitted to these inspections and tests is the same as that submitted for qualification inspection and tests.

#### 4.2.3 Responsibility

Acceptance inspections and tests shall be carried out by the manufacturer, or under his responsibility.

#### 4.2.4 Inspection and test report

A test report showing actual numerical values shall be provided if specified in the purchase order.

## 5 Requirements

See Table 1.

Table 1 — Technical requirements and test methods

Clause	Characteristic	Requirement	Inspection and test method	Q/A <sup>a</sup>	Sample size
5.1	Material	In accordance with the definition document	Chemical analysis or certificate of conformity issued by the manufacturer of the semi-finished product	Q	
5.2	Dimensions, tolerances and tolerances of form and position	In accordance with the definition document. A "GO" inspection gauge is to be fitted on the insert keys. On completion of this inspection, the keys shall neither be bent nor moved.	Standard gauging See Annex E.	Q	39
				A	Tables 3 and 4
5.3	Manufacturing				
5.3.1	Process	Insert threads may be produced by machining or forming.	Manufacturing method shall be indicated on test report.		
5.3.2	Heat treatment	The heat treatment medium or atmosphere shall not cause any surface contamination.  Any scale which will not be removed by subsequent machining shall be removed by abrasive blasting with an appropriate equipment.  The material shall be heat treated in accordance with the material specification defined in the definition document.	Calibration of the heat treatment equipment shall be confirmed.  Visual examination  Examination of the heat treatment specification		
5.3.3	Thread deformation (form out-of round)	Threads in the locking zone may be deformed in any manner provided that the insert meets the requirements of this standard.  The finished inserts shall allow the "GO" thread plug gauge to enter a minimum of three turns, when gauged from the installation side before engagement in the locking zone.	Standard gauging	Q	39
				A	Tables 3 and 4
5.3.4	Surface roughness	In accordance with the definition document	ISO 4288	Q	3
				A	Tables 3 and 4
5.3.5	Surface coating	In accordance with the definition document	See applicable coating standard.	Q	36
				A	Tables 3 and 4
				A	Table 6

(continued)

Table 1 (continued)

Clause	Characteristic	Requirement	Inspection and test method	Q/A <sup>a</sup>	Sample size
<b>5.4</b>	<b>Mechanical properties</b>				
<b>5.4.1</b>	<b>Installation requirement</b>	The screwing of insert shall be possible freely by hand. After testing, the inserts shall show no signs of: – buckling and/or incomplete fitting of the keys; – deformation of the internal thread of the insert caused by keys installation.	Inserts shall be installed into test block (see Annex A, normative) in accordance with EN 4619.  Use a tool specified in accordance with EN 4619.  Visual examination at a suitable magnification of $\times 10$ to $\times 20$  The recorded hardness of the test blocks must be indicated in the test report.	Q  A	5  Table 5
<b>5.4.1.1</b>	<b>into test block in aluminium</b>	See 5.4.1.	See 5.4.1.	Q	14
<b>5.4.1.2</b>	<b>into test block in corrosion resisting steel</b>	See 5.4.1.	See 5.4.1.	Q	16
<b>5.4.1.3</b>	<b>into test block in titanium alloy</b>	See 5.4.1.	See 5.4.1.	Q	6
<b>5.4.2</b>	<b>Rotational resistance</b>				
<b>5.4.2.1</b>	<b>into test block in aluminium alloy</b>	Inserts shall withstand the torque specified in Table B.1 without rotation.	Inserts shall be installed in accordance with 5.4.1.1.  The installed inserts shall be tested in a counter clockwise direction as shown in Annex B (normative).	Q	5
<b>5.4.2.2</b>	<b>into test block in corrosion resisting steel<sup>b</sup></b>	See 5.4.2.1.	Inserts shall be installed into test block in corrosion resisting steel (see Annex A).  Test method, see 5.4.2.1.	Q	5

(continued)

Table 1 (continued)

Clause	Characteristic	Requirement	Inspection and test method	Q/A <sup>a</sup>	Sample size
5.4.3	Axial load <sup>b</sup>	<p>Inserts shall withstand axial strength corresponding to the strength class given in the definition document or in the material specification.</p> <p>Insert shall not axially move from the test block.</p> <p>Minimal length of external thread of the insert shall be fixed in the producer design.</p> <p>After testing inserts shall be free from:</p> <ul style="list-style-type: none"> <li>– cracks;</li> <li>– tearing or deformation of the internal thread of the insert preventing disassembly of the bolt.</li> </ul> <p>Permanent distortion or loss up to 40 % of the locking torque with regard with the breakaway torque recorded before axial load application is acceptable.</p>	<p>Inserts shall be installed in accordance with 5.4.1.1 and 5.4.1.2.</p> <p>The breakaway torque shall be recorded.</p> <p>The axial strength values specified in Annex C (normative) or in the definition document shall apply.</p>	Q	6 <sup>c</sup>
5.4.4	Reusability	<p>General:</p> <p>After testing, inserts shall not show any indications of distortion, galling or scratches of such a depth as to prevent reassembly of bolts freely, by hand, up to the self-locking zone.</p> <p>Bolt threads shall remain serviceable and permit assembly with a new insert freely, by hand, up to the self-locking zone.</p>	<p>Test assembly see Annex D (normative)</p> <p>A new bolt shall be used for each complete three, five and 25 cycles test.</p> <p>The pitch diameter of the bolts selected shall be in the lower 1/3 of tolerance specified in ISO 5855-1 and ISO 5855-2.</p> <p>During testing, the pitch diameter of the bolts may be checked and if found to be below the minimum the bolt shall be replaced. A new bolt within the above stated limits shall be used. Bolts shall be lubricated with clean engine oil at the beginning of each cycle during testing.</p> <p>The seating and unseating torque shall be recorded for each cycle.</p>		

(continued)

Table 1 (continued)

Clause	Characteristic	Requirement	Inspection and test method	Q/A <sup>a</sup>	Sample size
5.4.4.1	<b>Self-locking torque at ambient temperature</b> (25 cycles)	Shall be between the minimum breakaway torque and the maximum self-locking torque Table D.1 for each cycle.	a) Inserts shall be installed in accordance with 5.4.1.1 (aluminium alloy).	Q	3
			Inserts shall be installed in accordance with 5.4.1.2 (corrosion resisting steel).	Q	4
			Inserts shall be installed in accordance with 5.4.1.3 (titanium alloy).	Q	3
			b) Assemble the bolt and spacer onto the test assembly ensuring that the bolt thread is not lubricated and protrudes at least two pitches beyond the self-locking zone. Measure the self-locking torque using a torque wrench. c) Apply the seating torque stipulated in Table D.1. d) Remove the load by unscrewing at least one half turn and stop. Again unscrew and measure the breakaway torque, using the same procedure. Remove the bolt from the insert. Repeat above a total of 25 times.		

(continued)

Table 1 (continued)

Clause	Characteristic	Requirement	Inspection and test method	Q/A <sup>a</sup>	Sample size
5.4.4.2	<b>Self-locking torque at ambient temperature</b> after baking (5 cycles)	Shall be between the minimum breakaway torque and the maximum self-locking torque Table D.1 for each cycle.	As 5.4.4.1, a) and b).  The assembly shall be loaded $R_{p0,2}$ value given by the material specification of the insert and heated in a furnace to:		
			— $(150 \pm 5)$ °C for assembly with test block in aluminium	Q	3
			— Maximal temperature given in the definition document for assembly with test block in corrosion resisting steel	Q	4
			— Maximal temperature given in the definition document for assembly with test block in titanium alloy, only for MoS <sub>2</sub> coated inserts	Q	3
			Held at this temperature for $6 \text{ h} \pm 15 \text{ min}$ removed from the furnace and cooled to ambient temperature.  Then proceed as 5.4.4.1, d), except cycles.  Repeat above a total of five times.		
5.4.4.3	<b>Self-locking torque at ambient temperature</b> (three cycles)	Shall be between the minimum breakaway torque and the maximum self-locking torque, see Table D.1, for each cycle.	Inserts shall be installed in accordance with 5.4.1.2  As 5.4.4.1  Repeat above a total of three	A	Table 5
5.4.4.4	<b>Condition of the internal thread after testing</b>	After the locking tests, the internal thread of the insert must be free from:  — cracks;  — deformations;  — fretting corrosion.	At magnification of 8 to 15	Q	20
				A	Table 5
5.4.5	<b>Hardness</b>	After final heat treatment the hardness shall be within the range specified in the product standard.	Longitudinal section of the insert and anywhere for the keys.	Q	5
				A	Table 5

(continued)

Table 1 (continued)

Clause	Characteristic	Requirement	Inspection and test method	Q/A <sup>a</sup>	Sample size
<b>5.5</b>	<b>Metallurgical properties</b>		NOTE The same test sample may be utilized for more than one test provided that none of the characteristics of the samples are altered during the examination procedure (see Table 2).		
<b>5.5.1</b>	<b>Microstructure</b>	Inserts, before thread deformation, shall have a microstructure of fully recrystallized material.	Transverse section of test samples shall be etched in a suitable solution.  Microscopic examination at a magnification of 100 ×	Q  A	2  Table 5
<b>5.5.2</b>	<b>Grain size</b>	Grain size, measured approximately at the geometrical centre of the half-section of the insert, shall be in accordance with the requirements of the material standard. It may vary according to section thickness and/or thread deformation, but shall, when compared with plate II of ASTM E 112, not be coarser than 3. Isolated grains not exceeding a mean diameter <sup>d</sup> of 0,5 mm are acceptable.	Longitudinal section of the sample shall be etched in a suitable solution.	Q  A	2  Table 5
<b>5.5.3</b>	<b>Surface discontinuities</b> (before coating or plating)	Inserts shall be examined for laps, seams and inclusions. See Table 6.  Care shall be exercised to avoid confusing cracks with other discontinuities.  Cracks are not allowed.	ISO 3452:1984  In the event of any doubt arising as to the nature of the defects detected, inspect nut under low magnification after sectioning.	Q  A	3  Tables 3 and 4
<b>5.6</b>	<b>Product identification</b>	Marking in accordance with the definition document	Visual examination	Q  A	36  Tables 3 and 4
<b>5.7</b>	<b>Packaging</b>	Inserts shall be packed in such a way as to prevent any damage or corrosion occurring in the course of handling, transportation and storage.  Each basic package shall only contain inserts with the same part number and batch number.	Visual examination	A	100 %

(continued)

**Table 1** (concluded)

Clause	Characteristic	Requirement	Inspection and test method	Q/A <sup>a</sup>	Sample size
<b>5.8</b>	<b>Labelling</b>	Each basic package shall bear a label upon which is legibly recorded: – designation as specified by the definition document; – quantity; – batch number; – manufacturer's name and trade mark.	Visual examination	A	100 %
<sup>a</sup> Q: Qualification, A: Acceptance. <sup>b</sup> This test covers use in titanium alloy due to higher hardness of test block in corrosion resisting steel (see Annex B). <sup>c</sup> Installed three inserts in test block in aluminium alloy and in corrosion resistant steel. <sup>d</sup> Mean diameter = the average of the major and minor axes of an individual grain.					



Table 2 — Allocation of qualification testing requirements

Type of test	Defined in	Insert sample number																																							
		1	2	3	4	5	6	7	8	9	10	11	12	13	14	15	16	17	18	19	20	21	22	23	24	25	26	27	28	29	30	31	32	33	34	35	36	37	38	39	
<b>Non-destructive tests</b>																																									
Dimensions, tolerances and tolerances of form and position	5.2	X	X	X	X	X	X	X	X	X	X	X	X	X	X	X	X	X	X	X	X	X	X	X	X	X	X	X	X	X	X	X	X	X	X	X	X	X	X	X	
Thread deformation	5.3.3	X	X	X	X	X	X	X	X	X	X	X	X	X	X	X	X	X	X	X	X	X	X	X	X	X	X	X	X	X	X	X	X	X	X	X	X	X	X	X	X
Surface roughness	5.3.4 <sup>a</sup>	X	X	X																																					
Surface coating	5.3.5				X	X	X	X	X	X	X	X	X	X	X	X	X	X	X	X	X	X	X	X	X	X	X	X	X	X	X	X	X	X	X	X	X	X	X	X	
Surface discontinuities	5.5.3 <sup>a</sup>	X	X	X																																					
Product identification	5.6				X	X	X	X	X	X	X	X	X	X	X	X	X	X	X	X	X	X	X	X	X	X	X	X	X	X	X	X	X	X	X	X	X	X	X	X	
<b>Destructive</b>																																									
Installation requirement	5.4.1																																								
into test block in aluminium	5.4.1.1				X	X	X	X	X	X	X	X	X	X	X	X	X																								
into test block in corrosion resisting steel	5.4.1.2																	X	X	X	X	X	X	X	X	X	X	X	X	X	X	X	X								
into test block in titanium alloy	5.4.1.3																																				X	X	X	X	X
Rotational resistance	5.4.2				X	X	X	X	X									X	X	X	X	X																			
Axial load	5.4.3								X	X	X												X	X	X																
Reusability	5.4.4											X	X	X													X	X	X	X						X	X	X			
– 25 cycles at ambient temperature	5.4.4.1																																								
– five cycles at ambient temperature after baking	5.4.4.2														X	X	X													X	X	X	X					X	X	X	
Condition of the internal thread after testing	5.4.4.4											X	X	X	X	X	X									X	X	X	X	X	X	X	X	X	X	X	X	X	X	X	
Hardness	5.4.5																									X	X	X	X							X					
Microstructure	5.5.1																									X	X	X	X							X					
Grain size	5.5.2																									X	X	X	X							X					

<sup>a</sup> Inspection to be carried out before MoS<sub>2</sub> coating (as applicable).

**Table 3 — Classification of defects**

Category of defect	AQL	Characteristic concerned
Major	0,065 %	Presence of locking element Surface discontinuities Position of the keys
	1,0 %	Thread size Coating Product marking Surface roughness
Minor	2,5 %	Burs and sharp corners
	4,0 %	Other dimensional characteristics not listed above

**Table 4 — Sampling plans for visual inspections and dimensional characteristics**

Batch size	Sample size	Acceptance number (Ac) and limiting quality (LQ <sub>10</sub> ) in accordance with the acceptance quality limit (AQL)							
		AQL 0,065 %		AQL 1,0 %		AQL 2,5 %		AQL 4,0 %	
		Ac	LQ <sub>10</sub> %	Ac	LQ <sub>10</sub> %	Ac	LQ <sub>10</sub> %	Ac	LQ <sub>10</sub> %
≤ 50	100 %	—	—	—	—	—	—	—	—
51 to 90	13	↓	—	00	16,20	↓	—	01	26,80
91 to 150	20	↓	↓	↑	↑	01	18,10	02	24,50
151 to 280	32	↓	↓	↓	↓	02	15,80	03	19,70
281 to 500	50	↓	↓	01	07,56	03	12,90	05	17,80
501 to 1 200	80	↓	↓	02	06,52	05	11,30	07	14,30
1 201 to 3 200	125	↓	↓	03	05,27	07	09,24	10	12,10
3 201 to 10 000	200	0	1,140	05	04,59	10	07,60	14	09,81
10 001 to 35 000	315	↑	↑	07	03,71	14	06,33	21	08,84
35 001 to 150 000	500	↓	↓	10	03,06	21	05,60	↑	—
150 001 to 500 000	800	1	0,485	14	02,51	↑	—	↑	—

↑ Use sampling plan above.

↓ Use sampling plan below.

The data given in this table are based on single sampling plans for a normal inspection, as specified in ISO 2859-1:1999, Tables 2-A and 6-A.

Other sampling plans specified in ISO 2859-1 may be used (double or multiple sampling), but these shall be chosen in such a way as to ensure an equivalent quality limit.

For those manufacturers who carry out an inspection during the manufacturing process (inspection on a machine and/or inspection between operations), the sampling plan for the final inspection shall be compiled in such a way that the overall inspection plan shall guarantee an equivalent quality limit.

**Table 5 — Sampling plans for the inspection of mechanical and metallurgical characteristics**

Batch size	Sample size		Acceptance number (Ac)
	Non-destructive tests A	Destructive tests B	
≤ 500	8	3	0
501 to 3 200	13	5	0
3 201 to 35 000	20	5	0
≥ 35 001	32	8	0

**Table 6 — Permissible surface discontinuities**

Dimensions in millimetres

Nominal thread diameter	Depth max.
5	0,12
6	0,13
7	
8	0,15
10	

## Annex A (normative)

### Definition of test block

See Figure A.1.

Dimensions in millimetres, values of surface roughness in micrometres.

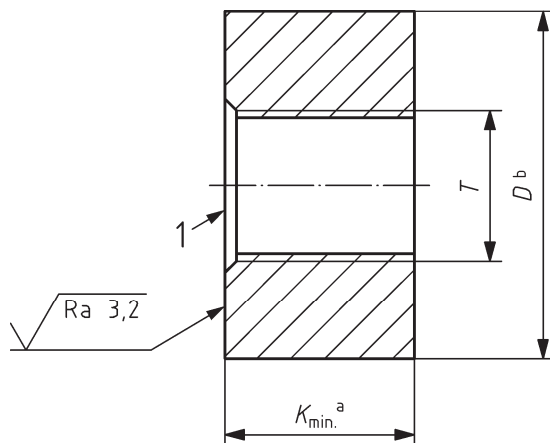

#### Key

- 1 Hole preparation EN 4620
- <sup>a</sup> In conformity with EN 4620
- <sup>b</sup> Across flats dimensions

Outside shape to be round, square or hexagonal.

$T$  is the nominal diameter of insert external thread.

$D\ min. = 2 \times T$

Figure A.1

#### Test block in aluminium alloy

Material: 2024-T3 according to EN 2638.

Hardness:  $\leq 120HB$ .

#### Test block in heat resisting steel

Material: FE-PM3801(17-4PH), for example: EN 3161.

Hardness:  $\geq 360HB$ .

#### Test block in titanium alloy

Material: TI-P63001(TA6V), for example: EN 3311.

Hardness:  $\geq 352HB$ .

## Annex B (normative)

### Assembly for rotational resistance test

See Figure B.1.

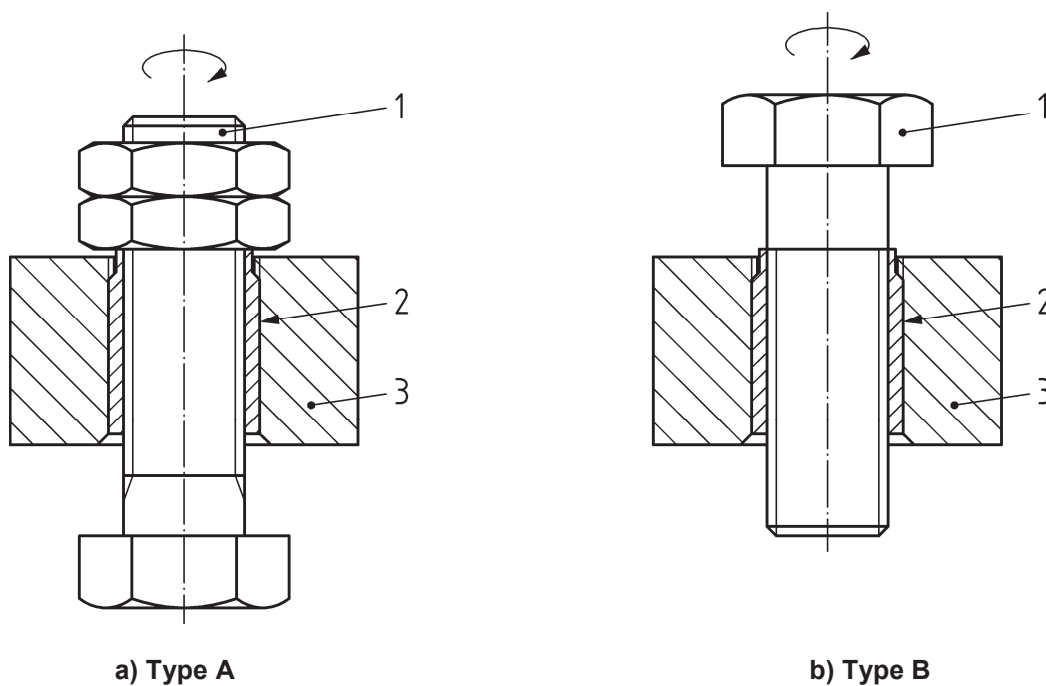

#### Key

- 1 Bolt
- 2 Installed inserts
- 3 Test block, see Annex A

**Figure B.1**

Definition of testing bolts: MJ profile class 4h6h matching the internal insert thread.

Other characteristics: all bolts ensuring installation shown in Figure B.1a) or Figure B.1b) are acceptable.

The rotational resistance test values are given in Table B.1.

Table B.1

Internal thread size	Torque Nm
MJ5 × 0,8	10
MJ6 × 1	16
MJ7 × 1	22
MJ8 × 1	33
MJ10 × 1,25	46

## Annex C (normative)

### Axial tensile strength test

See Figure C.1.

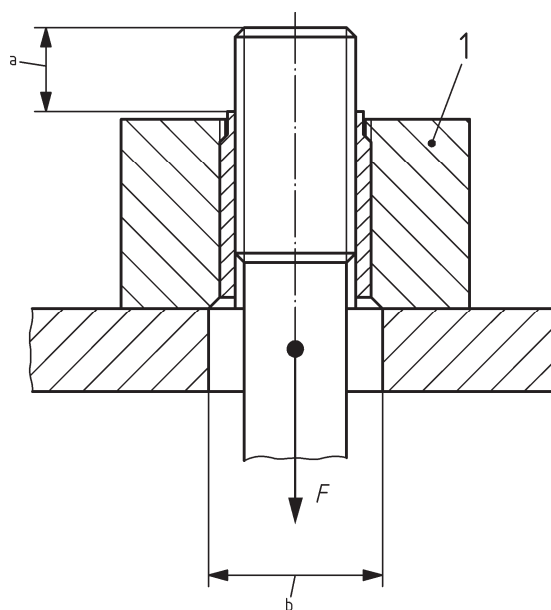

#### Key

- 1 Test block, see Annex A
- a Two pitches minimum
- b 1,5 times insert external thread

Figure C.1

Definition of testing bolts:

- a) thread = MJ profile class 4h6h matching the insert internal thread;
- b) material:
  - 1) for A286 inserts  $R_m \geq 1\,210$  MPa;
  - 2) for Inconel 718 inserts  $R_m \geq 1\,550$  MPa;
  - 3) for Waspaloy inserts  $R_m \geq 1\,240$  MPa;
- c) length = all bolts ensuring installation shown in Figure C.1;
- d) coating = none.

The axial load test values are given in Table C.1.

Table C.1

Internal thread size	Axial load <sup>a</sup>		
	kN		
	FE-PA2601	NI-P101HT	NI-P100HT
MJ5 × 0,8	16,8	17,4	23,7
MJ6 × 1	23,9	24,7	33,7
MJ7 × 1	34	35,3	47,9
MJ8 × 1	45,9	47,9	64,6
MJ10 × 1,25	71,6	74,8	101

NOTE Load requirements for axial tensile strength test are based on the following stresses:

- 1 550 MPa for NI-PH2601 (Inconel 718);
- 1 210 MPa for NI-PH1302 (Waspaloy);
- 1 100 MPa for FE-PA2601 (A286).

<sup>a</sup> Tensile stress area formula  $A = \pi/4 (d_3)^2 [2 - (d_3/d_2)^2]$   
where

- $A$  is the tensile stress area in square millimetres;
- $d_2$  is the max. pitch diameter class 4h6h in millimetres;
- $d_3$  is the max. root diameter class 4h6h in millimetres.



## Annex D (normative)

### Assembly for reusability test

See Figure D.1.

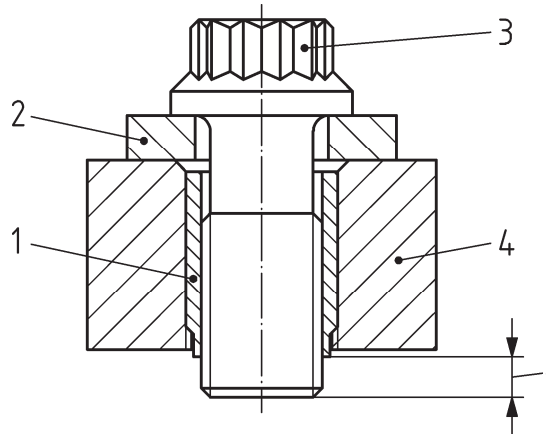

#### Key

- 1 Insert
  - 2 Spacer (material Inconel 718)
  - 3 Bolt (material stainless steel alloy A286, passivated and rolled thread to ISO 5855-1 and ISO 5855-2). The pitch diameter of the bolts selected shall have:
    - minimum value: the minimum value specified in ISO 5855-1 and ISO 5855-2;
    - maximum value: the minimum value specified in ISO 5855-1 and ISO 5855-2 plus third of the tolerance.
  - 4 Test block in corrosion resisting steel, see Annex A.
- a Two pitches minimum

**Figure D.1**

The values of breakaway torque, self-locking torque and seating torque are given in Table D.1.

Table D.1

Internal thread size	Breakaway torque			Self-locking torque		Seating torque		
	Nm			Nm		Nm		
	min. <sup>a</sup>	min. <sup>b</sup>	min. <sup>c</sup>	max. <sup>d</sup>	max. <sup>e</sup>	FE-PA2601 min. <sup>f</sup>	NI-PH1302 min. <sup>f</sup>	NI-PH2601 min. <sup>f</sup>
MJ5 × 0,8	0,25	0,5	0,3	2,0	4,0	6	8	14,5
MJ6 × 1	0,35	0,7	0,4	3,2	6,4	10	13	24,5
MJ7 × 1	0,5	1,1	0,6	4,6	9,2	16	22	40
MJ8 × 1	0,65	1,4	0,8	6,0	12,0	25	33	60
MJ10 × 1,25	1,2	2,4	1,4	9,5	19,0	46	64	116

<sup>a</sup> For 25 cycle test and five cycle test after baking.  
<sup>b</sup> For first cycle of three cycle test.  
<sup>c</sup> For second and third cycle of three cycle test.  
<sup>d</sup> For 25 cycle test and three cycle test.  
<sup>e</sup> For five cycle test after baking.  
<sup>f</sup> For 25 cycle test and three cycle test.

**Annex E**  
(normative)

**"GO" gauge for inspection of the position of the keys**

See Figure E.1.

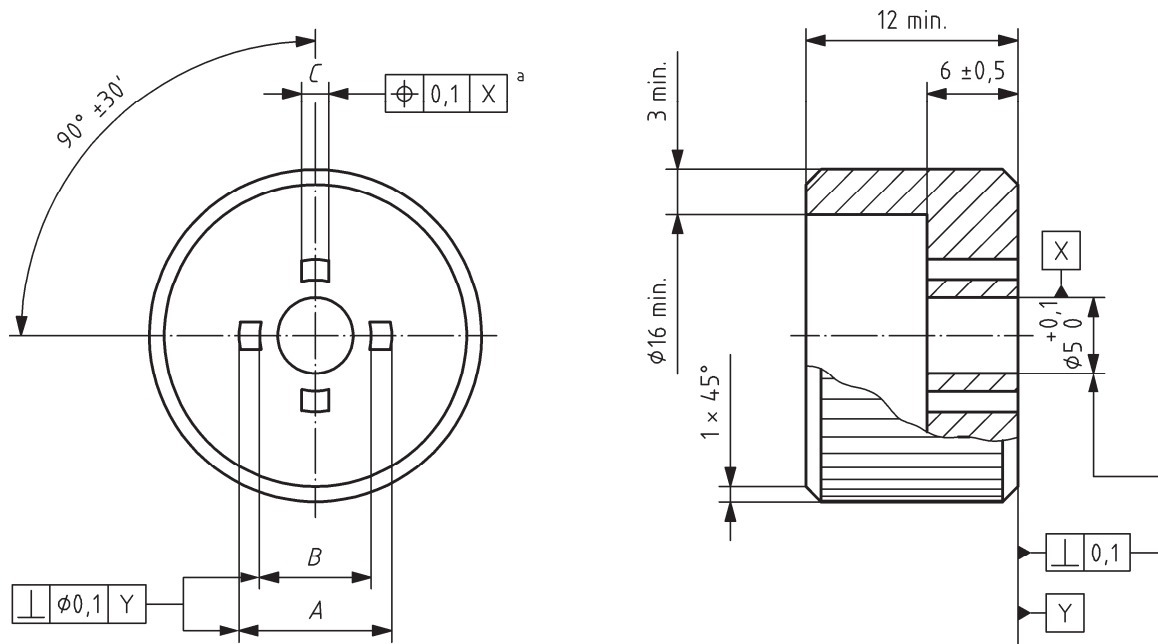

**Figure E.1**

**Table E.1**

Insert external thread	$\varnothing A$ $\pm 0,05$ 0	$\varnothing B$ $\pm 0,05$ 0	$C$ $\pm 0,05$ 0
MJ9 x 1	9,10	6,4	1,80
MJ10 x 1	10,10	7,4	
MJ11 x 1	11,10	8,4	
MJ12 x 1	12,10	9,4	
MJS13 x 1	13,10	10,4	
MJ14 x 1	14,10	11,4	
MJ15 x 1	15,10	12,4	
MJ16 x 1	16,10	13,4	

Material: Steel

Treatment hardness:  $\geq 50\text{HRc}$

See Figure E.2.

Inspection

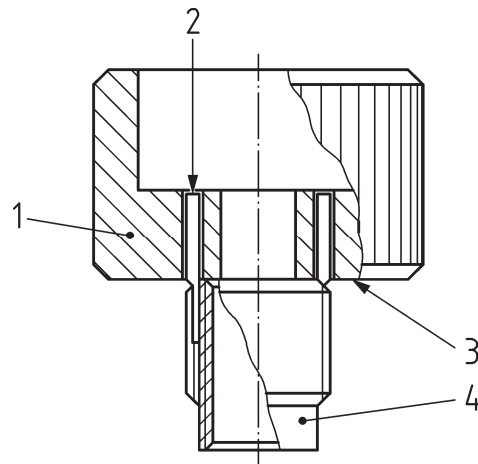

**Key**

- 1 Gauge
- 2 Visual inspection of the position of the keys
- 3 Insert bearing surface
- 4 Insert

**Figure E.2**



---

## BSI - British Standards Institution

BSI is the independent national body responsible for preparing British Standards. It presents the UK view on standards in Europe and at the international level. It is incorporated by Royal Charter.

### Revisions

British Standards are updated by amendment or revision. Users of British Standards should make sure that they possess the latest amendments or editions.

It is the constant aim of BSI to improve the quality of our products and services. We would be grateful if anyone finding an inaccuracy or ambiguity while using this British Standard would inform the Secretary of the technical committee responsible, the identity of which can be found on the inside front cover. Tel: +44 (0)20 8996 9000. Fax: +44 (0)20 8996 7400.

BSI offers members an individual updating service called PLUS which ensures that subscribers automatically receive the latest editions of standards.

### Buying standards

Orders for all BSI, international and foreign standards publications should be addressed to Customer Services. Tel: +44 (0)20 8996 9001. Fax: +44 (0)20 8996 7001 Email: [orders@bsigroup.com](mailto:orders@bsigroup.com) You may also buy directly using a debit/credit card from the BSI Shop on the Website <http://www.bsigroup.com/shop>

In response to orders for international standards, it is BSI policy to supply the BSI implementation of those that have been published as British Standards, unless otherwise requested.

### Information on standards

BSI provides a wide range of information on national, European and international standards through its Library and its Technical Help to Exporters Service. Various BSI electronic information services are also available which give details on all its products and services. Contact Information Centre. Tel: +44 (0)20 8996 7111 Fax: +44 (0)20 8996 7048 Email: [info@bsigroup.com](mailto:info@bsigroup.com)

Subscribing members of BSI are kept up to date with standards developments and receive substantial discounts on the purchase price of standards. For details of these and other benefits contact Membership Administration. Tel: +44 (0)20 8996 7002 Fax: +44 (0)20 8996 7001 Email: [membership@bsigroup.com](mailto:membership@bsigroup.com)

Information regarding online access to British Standards via British Standards Online can be found at <http://www.bsigroup.com/BSOL>

Further information about BSI is available on the BSI website at <http://www.bsigroup.com>.

### Copyright

Copyright subsists in all BSI publications. BSI also holds the copyright, in the UK, of the publications of the international standardization bodies. Except as permitted under the Copyright, Designs and Patents Act 1988 no extract may be reproduced, stored in a retrieval system or transmitted in any form or by any means – electronic, photocopying, recording or otherwise – without prior written permission from BSI.

This does not preclude the free use, in the course of implementing the standard, of necessary details such as symbols, and size, type or grade designations. If these details are to be used for any other purpose than implementation then the prior written permission of BSI must be obtained.

Details and advice can be obtained from the Copyright and Licensing Manager. Tel: +44 (0)20 8996 7070 Email: [copyright@bsigroup.com](mailto:copyright@bsigroup.com)