

**Aerospace series
— Bolts, normal
hexagonal head,
coarse tolerance
normal shank,
medium length thread,
in heat resisting
nickel base alloy,
aluminium IVD coated
— Classification: 1
250 MPa (at ambient
temperature) / 425 °C**

ICS 49.030.20,

National foreword

This British Standard is the UK implementation of EN 4131:2009.

The UK participation in its preparation was entrusted to Technical Committee ACE/12, Aerospace fasteners and fastening systems.

A list of organizations represented on this committee can be obtained on request to its secretary.

This publication does not purport to include all the necessary provisions of a contract. Users are responsible for its correct application.

Compliance with a British Standard cannot confer immunity from legal obligations.

This British Standard was published under the authority of the Standards Policy and Strategy Committee on 31 May 2009

© BSI 2009

ISBN 978 0 580 67789 2

Amendments/corrigenda issued since publication

Date	Comments

EUROPEAN STANDARD
NORME EUROPÉENNE
EUROPÄISCHE NORM

EN 4131

April 2009

ICS 49.030.20

English Version

**Aerospace series - Bolts, normal hexagonal head, coarse
tolerance normal shank, medium length thread, in heat resisting
nickel base alloy, aluminium IVD coated - Classification: 1 250
MPa (at ambient temperature) / 425 °C**

Série aérospatiale - Vis à tête hexagonale normale, tige
normale à tolérance large, filetage moyen, en alliage
résistant à chaud à base de nickel, revêtues aluminium IVD
- Classification : 1 250 MPa (à température ambiante) / 425
°C

Luft- und Raumfahrt - Sechskantschrauben, mittlere
Gewindelänge, aus hochwarmfester Nickelbasislegierung,
Aluminium IVD beschichtet - Klasse : 1 250 MPa (bei
Raumtemperatur) / 425 °C

This European Standard was approved by CEN on 12 March 2009.

CEN members are bound to comply with the CEN/CENELEC Internal Regulations which stipulate the conditions for giving this European Standard the status of a national standard without any alteration. Up-to-date lists and bibliographical references concerning such national standards may be obtained on application to the CEN Management Centre or to any CEN member.

This European Standard exists in three official versions (English, French, German). A version in any other language made by translation under the responsibility of a CEN member into its own language and notified to the CEN Management Centre has the same status as the official versions.

CEN members are the national standards bodies of Austria, Belgium, Bulgaria, Cyprus, Czech Republic, Denmark, Estonia, Finland, France, Germany, Greece, Hungary, Iceland, Ireland, Italy, Latvia, Lithuania, Luxembourg, Malta, Netherlands, Norway, Poland, Portugal, Romania, Slovakia, Slovenia, Spain, Sweden, Switzerland and United Kingdom.



EUROPEAN COMMITTEE FOR STANDARDIZATION
COMITÉ EUROPÉEN DE NORMALISATION
EUROPÄISCHES KOMITEE FÜR NORMUNG

Management Centre: Avenue Marnix 17, B-1000 Brussels

Contents

Page

Foreword.....	3
1 Scope	4
2 Normative references	4
3 Required characteristics	5
4 Designation	8
5 Marking	8
6 Technical specification	8

Foreword

This document (EN 4131:2009) has been prepared by the Aerospace and Defence Industries Association of Europe - Standardization (ASD-STAN).

After enquiries and votes carried out in accordance with the rules of this Association, this Standard has received the approval of the National Associations and the Official Services of the member countries of ASD, prior to its presentation to CEN.

This European Standard shall be given the status of a national standard, either by publication of an identical text or by endorsement, at the latest by October 2009, and conflicting national standards shall be withdrawn at the latest by October 2009.

Attention is drawn to the possibility that some of the elements of this document may be the subject of patent rights. CEN [and/or CENELEC] shall not be held responsible for identifying any or all such patent rights.

According to the CEN/CENELEC Internal Regulations, the national standards organizations of the following countries are bound to implement this European Standard: Austria, Belgium, Bulgaria, Cyprus, Czech Republic, Denmark, Estonia, Finland, France, Germany, Greece, Hungary, Iceland, Ireland, Italy, Latvia, Lithuania, Luxembourg, Malta, Netherlands, Norway, Poland, Portugal, Romania, Slovakia, Slovenia, Spain, Sweden, Switzerland and the United Kingdom.

1 Scope

This standard specifies the characteristics of bolts, normal hexagonal head, coarse tolerance normal shank, medium length thread, in heat resisting nickel base alloy, aluminium IVD coated.

Classification: 1 250 MPa ¹⁾ / 425 °C ²⁾

2 Normative references

The following referenced documents are indispensable for the application of this document. For dated references, only the edition cited applies. For undated references, the latest edition of the referenced document (including any amendments) applies

EN 2424, *Aerospace series — Marking of aerospace products*

EN 2952, *Aerospace series — Heat resisting alloy NI-PH2601 — Solution treated and cold worked — Bar for forged fasteners — $D \leq 50$ mm — $1\ 270$ MPa $\leq R_m \leq 1\ 550$ MPa ³⁾*

EN 3219, *Aerospace series — Heat resisting nickel base alloy (Ni-P100HT) — Cold worked and softened — Bar and wire for continuous forging or extrusion for fasteners — $3 \leq D \leq 30$ mm ³⁾*

EN 9100, *Aerospace series — Quality management systems — Requirements (based on ISO 9001:2000) and Quality systems — Model for quality assurance in design, development, production, installation and servicing (based on ISO 9001:1994)*

EN 9133, *Aerospace series — Quality management systems — Qualification procedure for aerospace standard parts*

ISO 3193, *Aerospace — Bolts, normal hexagonal head, normal shank, short or medium length MJ threads, metallic material, coated or uncoated, strength classes less than or equal to 1 100 MPa — Dimensions*

ISO 3353-1, *Aerospace — Lead and runout threads — Part 1: Rolled external threads*

ISO 5855-2, *Aerospace — MJ threads — Part 2: Limit dimensions for bolts and nuts*

ISO 7913, *Aerospace — Bolts and screws, metric — Tolerances of form and position*

ISO 9154, *Aerospace — Bolts, with MJ threads, made of heat-resistant nickel-based alloy, strength class 1 550 MPa — Procurement specification*

TR 3775, *Aerospace series — Bolts and pins — Materials ⁴⁾*

MIL-DTL-83488D, *Coating, aluminium, high purity ⁵⁾*

1) Minimum tensile strength of the material at ambient temperature.

2) Maximum that the bolt can withstand without continuous change in its original characteristics, after return to ambient temperature. The maximum temperature is determined by the surface treatment.

3) In preparation at the date of publication of this standard.

4) Published as ASD Technical Report at the date of publication of this standard.

5) Published by: Department of Defense (DOD), the Pentagon, Washington, D.C. 20301, USA.

3 Required characteristics

3.1 Configuration — Dimensions — Masses

See Figure 1 and Table 1.

Dimensions and tolerances are expressed in millimetres, in conformity with ISO 3193 ⁶⁾, and apply after surface treatment.

3.2 Tolerances of form and position

ISO 7913

3.3 Materials

EN 2952, EN 3219

or

TR 3775 (heat resisting nickel base alloy, classification 1 250 MPa).

3.4 Surface treatment

MIL-DTL-83488D, type II, class 3, 7 µm to 20 µm.

After aluminium deposit:

- a) mechanical blasting, followed by a chromate conversion coating within 24 h max. ⁷⁾;
- b) optional lubrication with cethylic alcohol (code E).

6) Except underhead radius R for diameter codes 050 to 200.

7) Products used shall be in conformity with national regulation into force.

$3,2 \sqrt{\quad} \left[\begin{array}{c} 1,6 \sqrt{\quad} \\ 0,8 \sqrt{\quad} \end{array} \right]$ Values in micrometres apply prior to surface treatment.

Break sharp edges 0,1 to 0,4.

Details of form not stated are left to the manufacturer's discretion.

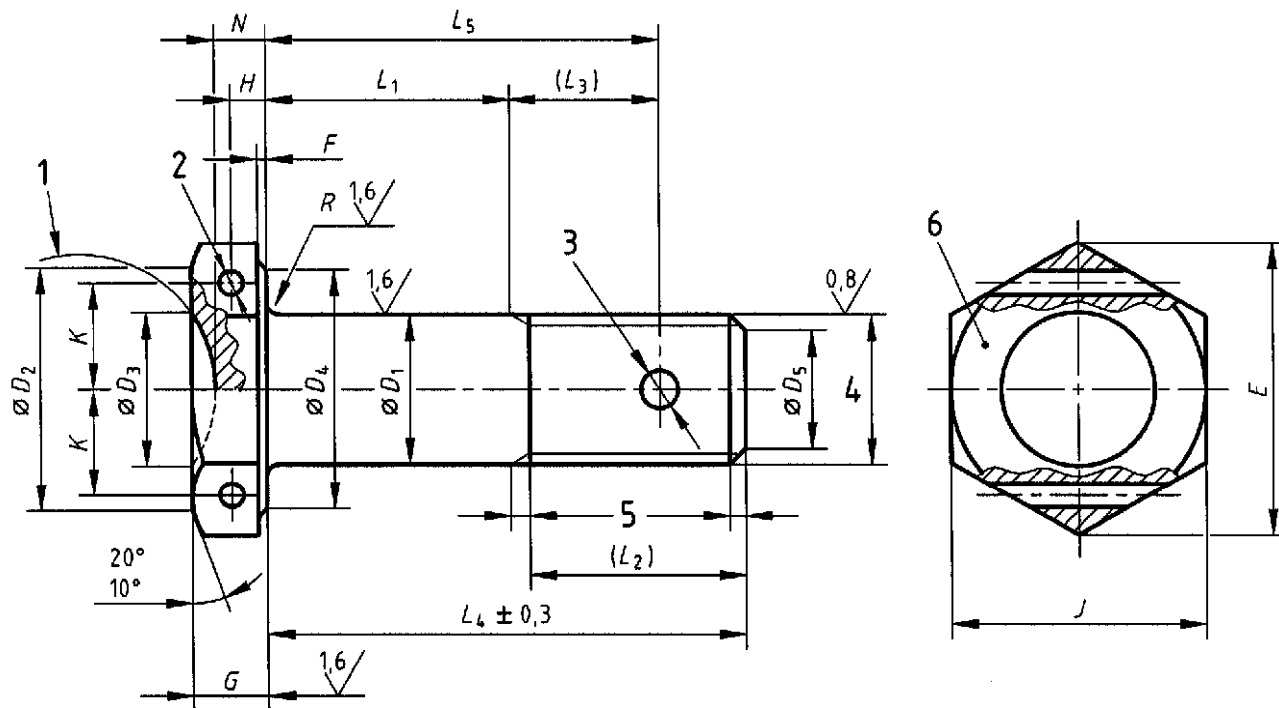

Key

- 1 Continuous surface
- 2 2 holes $\varnothing D_6$ (optional)
- 3 1 hole $\varnothing D_7$ (optional)
- 4 Thread
- 5 Conforms to ISO 3353-1
- 6 Marking

Figure 1

Table 1

Diameter code	Thread ^a	D_1	D_2	D_3	D_4 ^b	D_5		D_6	D_7	E	F		G	H
		h12	min.	0 - 0,5	min.	nom.	Tol.	H13	H13	min.	max.	min.	0 - 0,3	
030	MJ3×0,5 - 4h6h	3	5,5	—	5,4	2,3	0 - 0,5	—	—	6,5	0,4	0,2	2	—
040	MJ4×0,7 - 4h6h	4	6,4	—	6,4	3		—	1,1	7,6			2,5	—
050	MJ5×0,8 - 4h6h	5	7,4	5,25	7,4	3,4	± 0,5	1	1,5	8,7	0,5	0,3	3	1,35
060	MJ6×1 - 4h6h	6	9,4	6,25	9,3	4,2		1,4		10,9			3,5	1,6
070	MJ7×1 - 4h6h	7	10,3	7,25	10,2	5,2			1,9	12			4	1,85
080	MJ8×1 - 4h6h	8	12,3	8,25	12,2	6,2		2,4		14,3			4,5	2,1
100	MJ10×1,25 - 4h6h	10	16,3	10,25	16	7,9			3	18,9			5	2,35
120	MJ12×1,25 - 4h6h	12	18,3	12,25	18	9,8		3,8		21,1			6	2,85
140	MJ14×1,5 - 4h6h	14	21,3	14,25	21	11,5			1,6	24,5			7	3,35
160	MJ16×1,5 - 4h6h	16	23,3	16,25	23	13,5		3		26,8			8	3,85
180	MJ18×1,5 - 4h6h	18	26,3	18,25	26	15,5			3,8	30,2			9	4,35
200	MJ20×1,5 - 4h6h	20	29,3	20,25	29	17,5		33,6		10			4,85	

Diameter code	J		K	$L_1 \pm 0,2$ ^{c, d}		L_2	L_3	N	R		Mass ^e	
	nom.	Tol.		Length code	nom.				max.	min.	f	g
030	6	h12	—	002 to 030	2 to 30	7,5	—	—	0,4	0,2	0,968	0,057
040	7		—	002 to 040	2 to 40	10	6	—			1,913	0,103
050	8		3,25	003 to 050	3 to 50	12	7,5	2	0,5	0,3	3,387	0,160
060	10	h13	4,1	003 to 060	3 to 60	14	8,5	2,3	0,7	0,5	6,344	0,232
070	11		4,5	004 to 070	4 to 70	15	9,5	2,7			8,718	0,315
080	13		5,35	004 to 080	4 to 80	16,5	10,5	3			13,305	0,412
100	17		7,1	005 to 100	5 to 100	20,5	13	3,4	0,8	0,6	25,710	0,643
120	19		7,9	006 to 120	6 to 120	22,5	14,5	4	0,9		41,122	0,926
140	22		9,2	007 to 140	7 to 140	26	17	4,7	1,1	0,8	62,906	1,261
160	24		10,05	008 to 160	8 to 160	28,5	18,5	5,4			92,439	1,648
180	27		11,3	009 to 180	9 to 180	31	21	6	1,3	1	129,741	2,085
200	30		12,6	010 to 200	10 to 200	33,5	22,5	6,7			176,763	2,574

^a In accordance with ISO 5855-2.

^b D_4 max. shall be less than J .

^c Increments:
- 1 for $L_1 \leq 30$;
- 2 for $30 < L_1 \leq 100$;
- 4 for $L_1 > 100$.

^d If greater lengths are required, they shall be chosen using the above increments. The length code corresponds to the length L_1 , completed by one or two zeros to the left, where necessary, to obtain a three digit code.

^e Approximate values (kg/1 000 pieces), calculated on the basis of 8,195 kg/dm³, given for information purposes only. They apply to bolts without holes.

^f value for head and first L_4 .

^g Increase for each additional millimetre of L_4 .

4 Designation

EXAMPLE

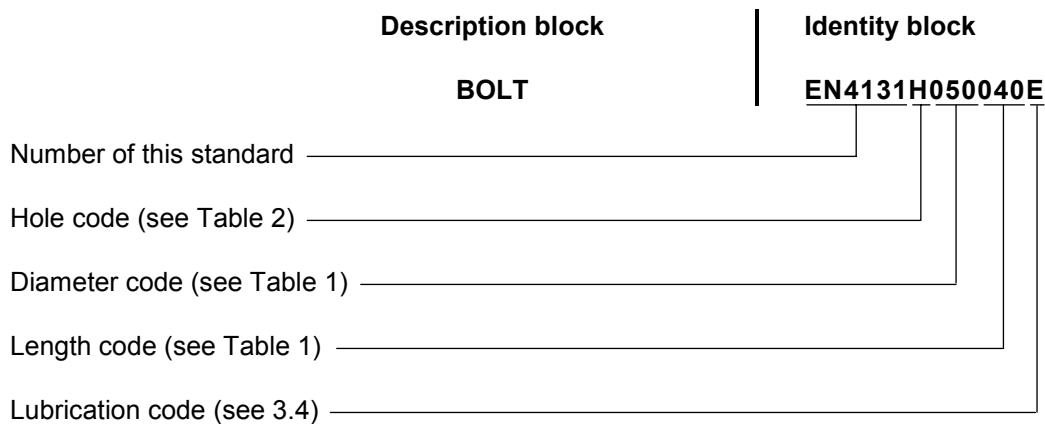

NOTE If necessary the originator code I9005 should be placed between the description block and the identity block.

Table 2

Holes	Code
Lockwire	H
Split pin	D
Lockwire and split pin	C
No hole	— (hyphen)

5 Marking

See Table 3 and Figure 1.

Table 3

Diameter code	EN 2424 Style
030 and 040	N
050 to 200	C + MJ

6 Technical specification

6.1 General

ISO 9154, with the following modifications.

6.2 Approval of manufacturers

EN 9100

6.3 Qualification of bolts

EN 9133

6.4 Other modified requirement

Test loads: apply the coefficient 0,81.

BSI - British Standards Institution

BSI is the independent national body responsible for preparing British Standards. It presents the UK view on standards in Europe and at the international level. It is incorporated by Royal Charter.

Revisions

British Standards are updated by amendment or revision. Users of British Standards should make sure that they possess the latest amendments or editions.

It is the constant aim of BSI to improve the quality of our products and services. We would be grateful if anyone finding an inaccuracy or ambiguity while using this British Standard would inform the Secretary of the technical committee responsible, the identity of which can be found on the inside front cover. Tel: +44 (0)20 8996 9000. Fax: +44 (0)20 8996 7400.

BSI offers members an individual updating service called PLUS which ensures that subscribers automatically receive the latest editions of standards.

Buying standards

Orders for all BSI, international and foreign standards publications should be addressed to Customer Services. Tel: +44 (0)20 8996 9001. Fax: +44 (0)20 8996 7001 Email: orders@bsigroup.com You may also buy directly using a debit/credit card from the BSI Shop on the Website <http://www.bsigroup.com/shop>

In response to orders for international standards, it is BSI policy to supply the BSI implementation of those that have been published as British Standards, unless otherwise requested.

Information on standards

BSI provides a wide range of information on national, European and international standards through its Library and its Technical Help to Exporters Service. Various BSI electronic information services are also available which give details on all its products and services. Contact Information Centre. Tel: +44 (0)20 8996 7111 Fax: +44 (0)20 8996 7048 Email: info@bsigroup.com

Subscribing members of BSI are kept up to date with standards developments and receive substantial discounts on the purchase price of standards. For details of these and other benefits contact Membership Administration. Tel: +44 (0)20 8996 7002 Fax: +44 (0)20 8996 7001 Email: membership@bsigroup.com

Information regarding online access to British Standards via British Standards Online can be found at <http://www.bsigroup.com/BSOL>

Further information about BSI is available on the BSI website at <http://www.bsigroup.com>.

Copyright

Copyright subsists in all BSI publications. BSI also holds the copyright, in the UK, of the publications of the international standardization bodies. Except as permitted under the Copyright, Designs and Patents Act 1988 no extract may be reproduced, stored in a retrieval system or transmitted in any form or by any means – electronic, photocopying, recording or otherwise – without prior written permission from BSI.

This does not preclude the free use, in the course of implementing the standard, of necessary details such as symbols, and size, type or grade designations. If these details are to be used for any other purpose than implementation then the prior written permission of BSI must be obtained.

Details and advice can be obtained from the Copyright and Licensing Manager. Tel: +44 (0)20 8996 7070 Email: copyright@bsigroup.com