

**Aerospace series —
Nuts, anchor, self-
locking, fixed, two
lug, reduced series,
with incremental
counterbore, in heat
resisting steel, MoS₂
lubricated —
Classification: 900
MPa (at ambient
temperature) / 315 °C**

ICS 49.030.30

National foreword

This British Standard is the UK implementation of EN 4125:2010.

The UK participation in its preparation was entrusted to Technical Committee ACE/12, Aerospace fasteners and fastening systems.

A list of organizations represented on this committee can be obtained on request to its secretary.

This publication does not purport to include all the necessary provisions of a contract. Users are responsible for its correct application.

Compliance with a British Standard cannot confer immunity from legal obligations.

This British Standard was published under the authority of the Standards Policy and Strategy Committee on 28 February 2010

© BSI 2010

ISBN 978 0 580 70532 8

Amendments/corrigenda issued since publication

Date	Comments

EUROPEAN STANDARD

EN 4125

NORME EUROPÉENNE

EUROPÄISCHE NORM

January 2010

ICS 49.030.30

English Version

Aerospace series - Nuts, anchor, self-locking, fixed, two lug, reduced series, with incremental counterbore, in heat resisting steel, MoS₂ lubricated - Classification: 900 MPa (at ambient temperature) / 315 °C

Série aérospatiale - Écrous à river, à freinage interne, fixes, double patte, série réduite, avec chambrage très profond, en acier résistant à chaud, lubrifiés MoS₂ - Classification : 900 MPa (à température ambiante) / 315 °C

Luft- und Raumfahrt - Anniemuttern, selbstsichernd, beiderseitig verkürzter Flansch, mit tiefer zylindrischer Aussenkung, aus hochwarmfestem Stahl, MoS₂-geschmiert - Klasse: 900 MPa (bei Raumtemperatur) / 315 °C

This European Standard was approved by CEN on 21 November 2009.

CEN members are bound to comply with the CEN/CENELEC Internal Regulations which stipulate the conditions for giving this European Standard the status of a national standard without any alteration. Up-to-date lists and bibliographical references concerning such national standards may be obtained on application to the CEN Management Centre or to any CEN member.

This European Standard exists in three official versions (English, French, German). A version in any other language made by translation under the responsibility of a CEN member into its own language and notified to the CEN Management Centre has the same status as the official versions.

CEN members are the national standards bodies of Austria, Belgium, Bulgaria, Croatia, Cyprus, Czech Republic, Denmark, Estonia, Finland, France, Germany, Greece, Hungary, Iceland, Ireland, Italy, Latvia, Lithuania, Luxembourg, Malta, Netherlands, Norway, Poland, Portugal, Romania, Slovakia, Slovenia, Spain, Sweden, Switzerland and United Kingdom.



EUROPEAN COMMITTEE FOR STANDARDIZATION
COMITÉ EUROPÉEN DE NORMALISATION
EUROPÄISCHES KOMITEE FÜR NORMUNG

Management Centre: Avenue Marnix 17, B-1000 Brussels

Contents

Page

Foreword.....	3
1 Scope	4
2 Normative references	4
3 Required characteristics	5
4 Designation	7
5 Marking	8
6 Technical specification	8

Foreword

This document (EN 4125:2010) has been prepared by the Aerospace and Defence Industries Association of Europe - Standardization (ASD-STAN).

After enquiries and votes carried out in accordance with the rules of this Association, this Standard has received the approval of the National Associations and the Official Services of the member countries of ASD, prior to its presentation to CEN.

This European Standard shall be given the status of a national standard, either by publication of an identical text or by endorsement, at the latest by July 2010, and conflicting national standards shall be withdrawn at the latest by July 2010.

Attention is drawn to the possibility that some of the elements of this document may be the subject of patent rights. CEN [and/or CENELEC] shall not be held responsible for identifying any or all such patent rights.

According to the CEN/CENELEC Internal Regulations, the national standards organizations of the following countries are bound to implement this European Standard: Austria, Belgium, Bulgaria, Croatia, Cyprus, Czech Republic, Denmark, Estonia, Finland, France, Germany, Greece, Hungary, Iceland, Ireland, Italy, Latvia, Lithuania, Luxembourg, Malta, Netherlands, Norway, Poland, Portugal, Romania, Slovakia, Slovenia, Spain, Sweden, Switzerland and the United Kingdom.

1 Scope

This standard specifies the characteristics of self-locking two lug, reduced series, incremental counterbored fixed anchor nuts, in heat resisting steel, MoS₂ lubricated.

Classification: 900 MPa¹⁾ / 315 °C²⁾.

2 Normative references

The following referenced documents are indispensable for the application of this document. For dated references, only the edition cited applies. For undated references, the latest edition of the referenced document (including any amendments) applies.

EN 2398, *Aerospace series — Heat resisting steel FE-PA2601 (X6NiCrTiMoV26-15) — $R_m \geq 900$ MPa — Bars for machined bolts — $D \leq 25$ mm*

EN 2399, *Aerospace series — Heat resisting steel FE-PA2601 (X4NiCrTiMoV26-15) — $R_m \geq 900$ MPa — Bars for forged bolts — $D \leq 25$ mm*

EN 2424, *Aerospace series — Marking of aerospace products*

EN 2491, *Aerospace series — Molybdenum disulphide dry lubricants — Coating methods*

EN 3638, *Aerospace series — Heat resisting alloy FE-PA2601 (X6NiCrTiMoV26-15) — Consumable electrode remelted — Solution and precipitation treated — Sheet, strip and plate — $0,5 \text{ mm} \leq a \leq 10 \text{ mm}$*

EN 3639, *Aerospace series — Heat resisting alloy FE-PA2601 — Softened and cold worked — Wire for forged fasteners — $D \leq 15 \text{ mm}$ — $900 \text{ MPa} \leq R_m \leq 1100 \text{ MPa}$ ³⁾*

EN 9100, *Quality Management Systems — Requirements for Aviation, Space and Defense Organizations*

EN 9133, *Aerospace series — Quality management systems — Qualification procedure for aerospace standard parts*

TR 3791, *Aerospace series — Materials for self-locking nuts, threaded inserts and screw thread inserts of temperature classes ≤ 425 °C⁴⁾*

ISO 5855-2, *Aerospace — MJ threads — Part 2: Limit dimensions for bolts and nuts*

ISO 5858, *Aerospace — Nuts, self-locking, with maximum operating temperature less than or equal to 425 °C — Procurement specification*

ISO 8788, *Aerospace — Nuts, metric — Tolerances of form and position*

1) Corresponds to the minimum tensile stress which the nut is able to withstand at ambient temperature without breaking or cracking when tested with a bolt of a higher strength class.

2) Maximum temperature that the nut is able to withstand, without permanent alteration to its original characteristics, after ambient temperature has been restored. The maximum temperature is conditioned by the surface treatment.

3) Published as ASD-STAN Prestandard at the date of publication of this standard.

4) Published as ASD-STAN Technical Report at the date of publication of this standard.

3 Required characteristics

3.1 Configuration — Dimensions — Masses

See Figure 1 and Table 1.

Dimensions and tolerances are expressed in millimetres and apply before MoS₂ lubrication.

Details of form not stated are at the manufacturer's option.

3.2 Tolerances of form and position

ISO 8788.

3.3 Materials

EN 2398, EN 2399, EN 3638, EN 3639 or TR 3791.

3.4 Surface treatment

EN 2491, thickness not specified.

6,3 / [3,2]

These values in micrometres apply before surface treatment. The values do not apply to threads and sheared edges the surface texture of which will be achieved by usual manufacturing methods.

Remove sharp edges 0,1 to 0,4.

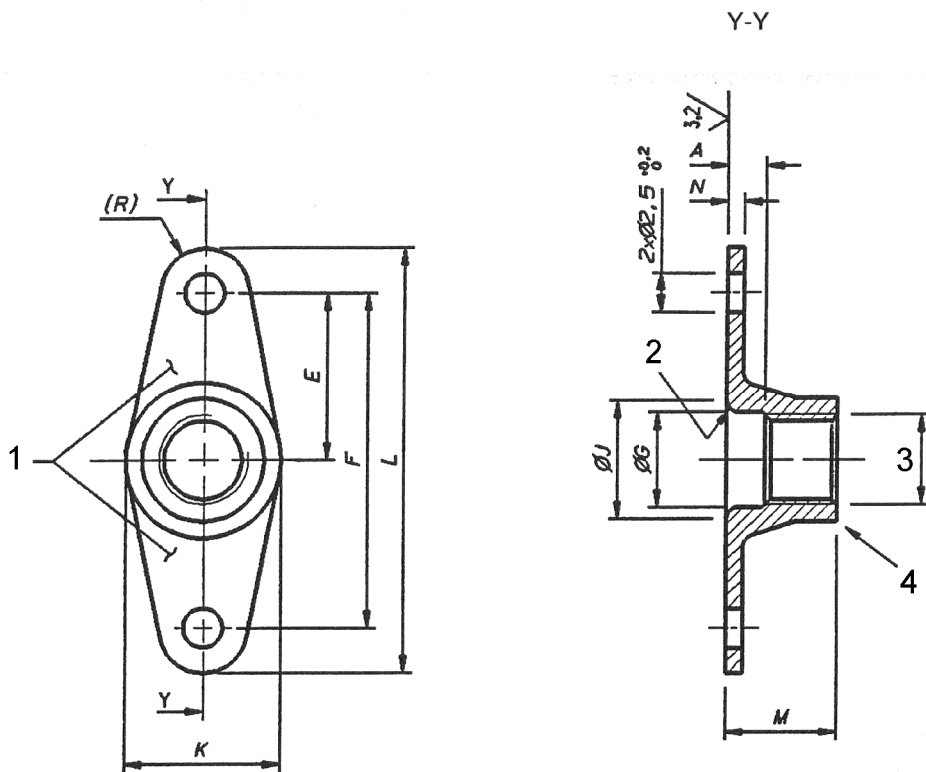

Key

- 1 Marking
- 2 Radius or chamfer
- 3 Thread
- 4 Form out-of-round in this area to achieve self-locking. Tooling marks are permitted in this area.

Figure 1

Table 1

Diameter code	Thread ^a	A		E	F	G	J ^b	K	L	M	N ^c	R	Mass ^d
		Counterbore code	min.										
050	MJ5×0,8-4H6H	04	4	7	14	5,5	7,3	9	19,2	8,5	1,1	2,5	1,2
		06	6							10,5			1,7
		08	8							12,5			2,1
		10	10							14,5			2,5
060	MJ6×1-4H5H	04	4	8	16	6,5	8,7	10	22,2	9,4	1,35	3	1,8
		06	6							11,4			2,1
		08	8							13,4			2,5
		10	10							15,4			3,0

^a In accordance with ISO 5855-2. In the self-locking zone, the tolerances apply before forming out-of-round.

^b Is to sharp corners (chamfered) or point of tangency (radiused).

^c Is applicable at the rivet hole location.

^d Approximate values (kg/1 000 pieces), calculated on the basis of 7,85 kg/dm³, given for information purposes only.

4 Designation

EXAMPLE

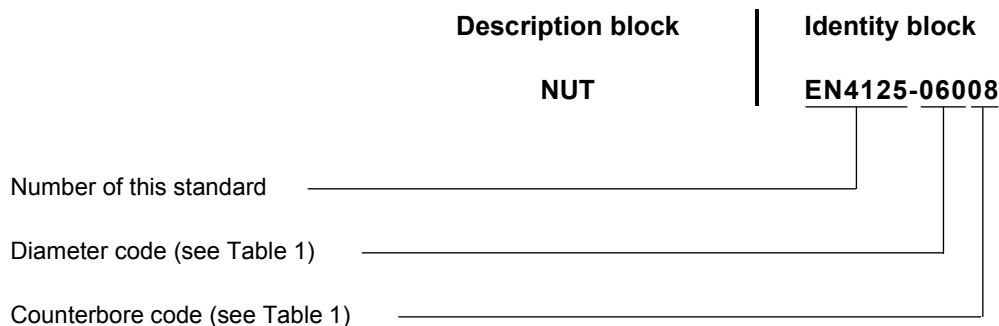

NOTE If necessary the originator code I9005 shall be placed between the description block and the identity block.

5 Marking

EN 2424, style N. See Figure 1.

6 Technical specification

ISO 5858, except for:

- Approval of manufacturers: see EN 9100;
- Qualification of products: see EN 9133.

BSI - British Standards Institution

BSI is the independent national body responsible for preparing British Standards. It presents the UK view on standards in Europe and at the international level. It is incorporated by Royal Charter.

Revisions

British Standards are updated by amendment or revision. Users of British Standards should make sure that they possess the latest amendments or editions.

It is the constant aim of BSI to improve the quality of our products and services. We would be grateful if anyone finding an inaccuracy or ambiguity while using this British Standard would inform the Secretary of the technical committee responsible, the identity of which can be found on the inside front cover. Tel: +44 (0)20 8996 9000. Fax: +44 (0)20 8996 7400.

BSI offers members an individual updating service called PLUS which ensures that subscribers automatically receive the latest editions of standards.

Buying standards

Orders for all BSI, international and foreign standards publications should be addressed to Customer Services. Tel: +44 (0)20 8996 9001. Fax: +44 (0)20 8996 7001 Email: orders@bsigroup.com You may also buy directly using a debit/credit card from the BSI Shop on the Website <http://www.bsigroup.com/shop>

In response to orders for international standards, it is BSI policy to supply the BSI implementation of those that have been published as British Standards, unless otherwise requested.

Information on standards

BSI provides a wide range of information on national, European and international standards through its Library and its Technical Help to Exporters Service. Various BSI electronic information services are also available which give details on all its products and services. Contact Information Centre. Tel: +44 (0)20 8996 7111 Fax: +44 (0)20 8996 7048 Email: info@bsigroup.com

Subscribing members of BSI are kept up to date with standards developments and receive substantial discounts on the purchase price of standards. For details of these and other benefits contact Membership Administration. Tel: +44 (0)20 8996 7002 Fax: +44 (0)20 8996 7001 Email: membership@bsigroup.com

Information regarding online access to British Standards via British Standards Online can be found at <http://www.bsigroup.com/BSOL>

Further information about BSI is available on the BSI website at <http://www.bsigroup.com>.

Copyright

Copyright subsists in all BSI publications. BSI also holds the copyright, in the UK, of the publications of the international standardization bodies. Except as permitted under the Copyright, Designs and Patents Act 1988 no extract may be reproduced, stored in a retrieval system or transmitted in any form or by any means – electronic, photocopying, recording or otherwise – without prior written permission from BSI.

This does not preclude the free use, in the course of implementing the standard, of necessary details such as symbols, and size, type or grade designations. If these details are to be used for any other purpose than implementation then the prior written permission of BSI must be obtained.

Details and advice can be obtained from the Copyright and Licensing Manager. Tel: +44 (0)20 8996 7070 Email: copyright@bsigroup.com

BSI Group
Headquarters 389
Chiswick High Road,
London, W4 4AL, UK
Tel +44 (0)20 8996 9001
Fax +44 (0)20 8996 7001
[www.bsigroup.com/
standards](http://www.bsigroup.com/standards)