

Aerospace series — Clearance for wrenches and sockets

ICS 49.030.99

National foreword

This British Standard is the UK implementation of EN 3819:2008.

The UK participation in its preparation was entrusted to Technical Committee ACE/12, Aerospace fasteners and fastening systems.

A list of organizations represented on this committee can be obtained on request to its secretary.

This publication does not purport to include all the necessary provisions of a contract. Users are responsible for its correct application.

Compliance with a British Standard cannot confer immunity from legal obligations.

This British Standard was published under the authority of the Standards Policy and Strategy Committee on 31 July 2008

© BSI 2008

ISBN 978 0 580 63579 3

Amendments/corrigenda issued since publication

Date	Comments

ICS 49.030.99

English Version

Aerospace series - Clearance for wrenches and sockets

Série aérospatiale - Dégagements pour clés et douilles

Luft- und Raumfahrt - Platzbedarf für Schraubwerkzeuge

This European Standard was approved by CEN on 12 December 2007.

CEN members are bound to comply with the CEN/CENELEC Internal Regulations which stipulate the conditions for giving this European Standard the status of a national standard without any alteration. Up-to-date lists and bibliographical references concerning such national standards may be obtained on application to the CEN Management Centre or to any CEN member.

This European Standard exists in three official versions (English, French, German). A version in any other language made by translation under the responsibility of a CEN member into its own language and notified to the CEN Management Centre has the same status as the official versions.

CEN members are the national standards bodies of Austria, Belgium, Bulgaria, Cyprus, Czech Republic, Denmark, Estonia, Finland, France, Germany, Greece, Hungary, Iceland, Ireland, Italy, Latvia, Lithuania, Luxembourg, Malta, Netherlands, Norway, Poland, Portugal, Romania, Slovakia, Slovenia, Spain, Sweden, Switzerland and United Kingdom.



EUROPEAN COMMITTEE FOR STANDARDIZATION
COMITÉ EUROPÉEN DE NORMALISATION
EUROPÄISCHES KOMITEE FÜR NORMUNG

Management Centre: rue de Stassart, 36 B-1050 Brussels

Contents

Page

Foreword.....3

1 Scope4

2 Normative references4

3 Clearance for box wrench according to EN 37114

4 Clearance for socket wrench according to EN 37105

Figures

Figure 1 4

Figure 2 4

Figure 3 4

Figure 4 5

Figure 5 5

Tables

Table 1..... 5

Table 2..... 6

Foreword

This document (EN 3819:2008) has been prepared by the Aerospace and Defence Industries Association of Europe - Standardization (ASD-STAN).

After enquiries and votes carried out in accordance with the rules of this Association, this Standard has received the approval of the National Associations and the Official Services of the member countries of ASD, prior to its presentation to CEN.

This European Standard shall be given the status of a national standard, either by publication of an identical text or by endorsement, at the latest by November 2008, and conflicting national standards shall be withdrawn at the latest by November 2008.

Attention is drawn to the possibility that some of the elements of this document may be the subject of patent rights. CEN [and/or CENELEC] shall not be held responsible for identifying any or all such patent rights.

According to the CEN/CENELEC Internal Regulations, the national standards organizations of the following countries are bound to implement this European Standard: Austria, Belgium, Bulgaria, Cyprus, Czech Republic, Denmark, Estonia, Finland, France, Germany, Greece, Hungary, Iceland, Ireland, Italy, Latvia, Lithuania, Luxembourg, Malta, Netherlands, Norway, Poland, Portugal, Romania, Slovakia, Slovenia, Spain, Sweden, Switzerland and the United Kingdom.

1 Scope

This standard defines the minimum clearance area required around nuts and bolt heads when using either double hexagon box or socket wrenches defined in AECMA standard.

2 Normative references

The following referenced documents are indispensable for the application of this document. For dated references, only the edition cited applies. For undated references, the latest edition of the referenced document (including any amendments) applies.

EN 3710, *Aerospace series — Sockets, bi-hexagonal — Technical Specification*¹⁾

EN 3711, *Aerospace series — Wrench-double ended, bi-hexagonal — Straight, cranked, offset*¹⁾

3 Clearance for box wrench according to EN 3711

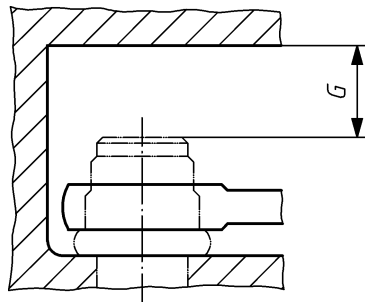

Figure 1

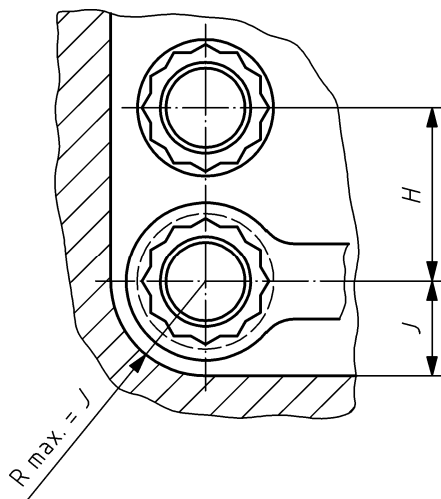

Figure 2

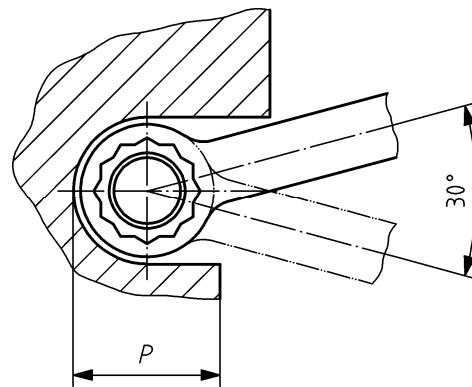

Figure 3

1) Published as AECMA prestandard at the date of publication of this standard.

Table 1

Across flats	<i>G</i> mm min.	<i>H</i> mm min.	<i>J</i> mm min.	<i>P</i> mm max.
6	7	11	6	9
7	7,5	12	6,5	11
8	8	13,5	7,5	12,5
9	9	15	8	15,5
10	10	16,5	9	14
11	10,5	18	9,5	16,5
12	11	19,5	10,5	20
14	11,5	21,5	11,5	21,5
17	13	26	13,5	30,5
19	14	28,5	15	31
22	15	32,5	17	39

4 Clearance for socket wrench according to EN 3710

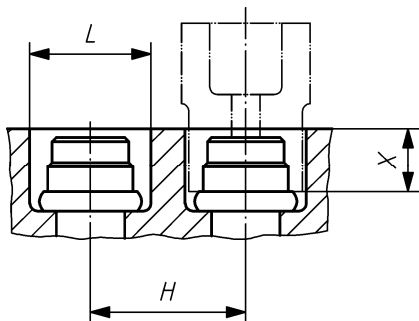

Figure 4

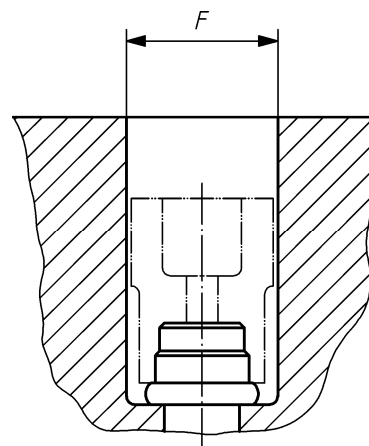

Figure 5

Table 2

Square drive		Across flats	<i>L</i> mm min.	<i>H</i> mm min.	<i>X_S</i> ^a mm	<i>X_l</i> ^b mm	<i>F</i> mm min.	
mm	inch							
6,35	1/4	5	∅ 9	10	8	28	∅ 12,5	
		6	∅ 10,5	11,5				
		7	∅ 12	13			∅ 13	
		8	∅ 13,5	14,5				
		9	∅ 14,5	15,5				∅ 15
10	3/8	7	∅ 12	13	9	22	∅ 18,5	
		8	∅ 13,5	14,5				
		9	∅ 14,5	15,5				
		10	∅ 16	17				
		11	∅ 17	18				
		12	∅ 18,5	19,5				
		13	∅ 19,5	20,5			∅ 23,5	
12,7	1/2	10	∅ 16	17	16	46	∅ 25	
		11	∅ 17	18				
		12	∅ 18,5	19,5				
		13	∅ 19,5	20,5				
		14	∅ 21,5	22,5				
		15	∅ 23	24				
		16	∅ 24	25			∅ 26	
		17	∅ 25,5	26,5				
		18	∅ 26,5	27,5				
		19	∅ 28	29				
		20	∅ 29	30				
		21	∅ 30,5	31,5				∅ 28
		22	∅ 31,5	32,5				∅ 29
						∅ 30,5		
						∅ 31,5		

^a Standard serial.
^b Length serial.

British Standards Institute (BSI)

BSI is the independent national body responsible for preparing British Standards. It presents the UK view on standards in Europe and at the international level. It is incorporated by Royal Charter.

Revisions

British Standards are updated by amendment or revision. Users of British Standards should make sure that they possess the latest amendments or editions.

It is the constant aim of BSI to improve the quality of our products and services. We would be grateful if anyone finding an inaccuracy or ambiguity while using this British Standard would inform the Secretary of the technical committee responsible, the identity of which can be found on the inside front cover.
Tel: +44 (0)20 8996 9000 Fax: +44 (0)20 8996 7400

BSI offers members an individual updating service called PLUS which ensures that subscribers automatically receive the latest editions of standards.

Buying standards

Orders for all BSI, international and foreign standards publications should be addressed to Customer Services.

Tel: +44 (0)20 8996 9001 Fax: +44 (0)20 8996 7001

Email: orders@bsigroup.com

You may also buy directly using a debit/credit card from the BSI Shop on the Website <http://www.bsigroup.com/shop>.

In response to orders for international standards, it is BSI policy to supply the BSI implementation of those that have been published as British Standards, unless otherwise requested.

Information on standards

BSI provides a wide range of information on national, European and international standards through its Library and its Technical Help to Exporters Service. Various BSI electronic information services are also available which give details on all its products and services. Contact the Information Centre.

Tel: +44 (0)20 8996 7111 Fax: +44 (0)20 8996 7048

Email: info@bsigroup.com

Subscribing members of BSI are kept up to date with standards developments and receive substantial discounts on the purchase price of standards. For details of these and other benefits contact Membership Administration.

Tel: +44 (0)20 8996 7002 Fax: +44 (0)20 8996 7001

Email: membership@bsigroup.com

Information regarding online access to British Standards via British Standards Online can be found at <http://www.bsigroup.com/BSOL>.

Further information about BSI is available on the BSI website at <http://www.bsigroup.com>.

Copyright

Copyright subsists in all BSI publications. BSI also holds the copyright, in the UK, of the publications of the international standardization bodies. Except as permitted under the Copyright, Designs and Patents Act 1988 no extract may be reproduced, stored in a retrieval system or transmitted in any form or by any means – electronic, photocopying, recording or otherwise – without prior written permission from BSI.

This does not preclude the free use, in the course of implementing the standard, of necessary details such as symbols, and size, type or grade designations. If these details are to be used for any other purpose than implementation then the prior written permission of BSI must be obtained.

Details and advice can be obtained from the Copyright & Licensing Manager.

Tel: +44 (0)20 8996 7070 Email: copyright@bsigroup.com