

Aerospace series — Cables, electrical, aircraft use — Test methods

Part 407 : Flammability

ICS 13.220.40; 49.060

National foreword

This British Standard is the UK implementation of EN 3475-407:2009. It supersedes BS EN 3475-407:2005 which is withdrawn.

The UK participation in its preparation was entrusted to Technical Committee ACE/6, Aerospace avionic electrical and fibre optic technology.

A list of organizations represented on this committee can be obtained on request to its secretary.

This publication does not purport to include all the necessary provisions of a contract. Users are responsible for its correct application.

Compliance with a British Standard cannot confer immunity from legal obligations.

This British Standard was published under the authority of the Standards Policy and Strategy Committee on 30 September 2009

© BSI 2009

ISBN 978 0 580 67322 1

Amendments/corrigenda issued since publication

Date	Comments

EUROPEAN STANDARD
NORME EUROPÉENNE
EUROPÄISCHE NORM

EN 3475-407

August 2009

ICS 13.220.40; 49.060

Supersedes EN 3475-407:2005

English Version

**Aerospace series - Cables, electrical, aircraft use - Test
methods - Part 407: Flammability**

Série aérospatiale - Câbles électriques à usage
aéronautique - Méthodes d'essais - Partie 407 : Tenue à la
flamme

Luft- und Raumfahrt - Elektrische Leitungen für
Luftfahrtverwendung - Prüfverfahren - Teil 407:
Entflammbarkeit

This European Standard was approved by CEN on 20 June 2009.

CEN members are bound to comply with the CEN/CENELEC Internal Regulations which stipulate the conditions for giving this European Standard the status of a national standard without any alteration. Up-to-date lists and bibliographical references concerning such national standards may be obtained on application to the CEN Management Centre or to any CEN member.

This European Standard exists in three official versions (English, French, German). A version in any other language made by translation under the responsibility of a CEN member into its own language and notified to the CEN Management Centre has the same status as the official versions.

CEN members are the national standards bodies of Austria, Belgium, Bulgaria, Cyprus, Czech Republic, Denmark, Estonia, Finland, France, Germany, Greece, Hungary, Iceland, Ireland, Italy, Latvia, Lithuania, Luxembourg, Malta, Netherlands, Norway, Poland, Portugal, Romania, Slovakia, Slovenia, Spain, Sweden, Switzerland and United Kingdom.



EUROPEAN COMMITTEE FOR STANDARDIZATION
COMITÉ EUROPÉEN DE NORMALISATION
EUROPÄISCHES KOMITEE FÜR NORMUNG

Management Centre: Avenue Marnix 17, B-1000 Brussels

Contents

Page

Foreword.....	3
1 Scope	4
2 Normative references	4
3 Equipment	4
4 Procedures	4
5 Acceptance criteria	8

Foreword

This document (EN 3475-407:2009) has been prepared by the Aerospace and Defence Industries Association of Europe - Standardization (ASD-STAN).

After enquiries and votes carried out in accordance with the rules of this Association, this Standard has received the approval of the National Associations and the Official Services of the member countries of ASD, prior to its presentation to CEN.

This European Standard shall be given the status of a national standard, either by publication of an identical text or by endorsement, at the latest by February 2010, and conflicting national standards shall be withdrawn at the latest by February 2010.

Attention is drawn to the possibility that some of the elements of this document may be the subject of patent rights. CEN [and/or CENELEC] shall not be held responsible for identifying any or all such patent rights.

This document supersedes EN 3475-407:2005.

According to the CEN/CENELEC Internal Regulations, the national standards organizations of the following countries are bound to implement this European Standard: Austria, Belgium, Bulgaria, Cyprus, Czech Republic, Denmark, Estonia, Finland, France, Germany, Greece, Hungary, Iceland, Ireland, Italy, Latvia, Lithuania, Luxembourg, Malta, Netherlands, Norway, Poland, Portugal, Romania, Slovakia, Slovenia, Spain, Sweden, Switzerland and the United Kingdom.

1 Scope

This standard specifies two methods of determining the flammability characteristics of a finished cable.

It is intended to be used together with EN 3475-100.

2 Normative references

The following referenced documents are indispensable for the application of this document. For dated references, only the edition cited applies. For undated references, the latest edition of the referenced document (including any amendments) applies.

EN 3475-100, *Aerospace series — Cables, electrical, aircraft use — Test methods — Part 100: General*.

FAR 25, *Airworthiness standards — Transport category airplanes*.

JAR 25, *Large aeroplanes*.

3 Equipment

The following equipment shall be required for these tests:

- a) **Test chamber:** this shall be a chamber measuring not less than 700 mm high × 300 mm wide × 300 mm deep, open at the top, open at the front and situated in a draught-free environment but with sufficient air supply to provide normal combustion. General arrangements are shown in Figures 1 and 2.
- b) **Bunsen type gas burner:** the burner shall have a 6 mm inlet, a needle valve in the base for gas adjustment, a nominal bore of 9 mm and a barrel of approximately 100 mm above the air inlets. The gas supply shall be capable of achieving the test requirements defined in 4.1.2 and 4.2.2.

WARNING — NOTE Care should be exercised in setting up and performing this test as toxic fumes may be given off during combustion. The test chamber shall be placed in a fume cabinet that will allow evacuation of gaseous products of combustion at the end of the test.

4 Procedures

4.1 Method 1

4.1.1 Preparation of test specimens

Cut two sets of three specimens each, approximately 900 mm in length, consecutively from the same coil. Strip each end and place them in an atmosphere of (50 ± 5) % relative humidity at a temperature of (21 ± 3) °C for a period of not less than 24 h. Keep the specimens in the conditioning area until just prior to testing.

4.1.2 Flame temperature

4.1.2.1 Adjust the Bunsen burner to produce a flame with an inner blue cone approximately one-third of the overall flame height. Insert a bare copper wire of $(0,7 \pm 0,025)$ mm diameter, and having a free length of not less than 100 mm, into the flame, the end of the wire being immediately above the tip of the inner cone.

NOTE For initial setting-up purposes, an overall flame height of approximately 75 mm may be found suitable.

4.1.2.2 Adjust the burner so that the wire starts to melt within 4 s to 6 s of being inserted into the flame.

NOTE Alternatively for 4.1.2.1 and 4.1.2.2, a 0,8 mm to 0,81 mm diameter wire may be used in which case adjust the burner so that the wire starts to melt within 7 s to 9 s.

4.1.3 Mounting configuration

4.1.3.1 Mount the specimen in the test chamber as shown in Figure 1 at an angle of $(60 \pm 2)^\circ$ to the horizontal, parallel to, and approximately 150 mm from the front end of the test chamber. Clamp the conductor at the bottom of the apparatus. Pass the cable over the upper pulley and attach it to a weight which is just sufficient to keep the specimen straight within the test zone.

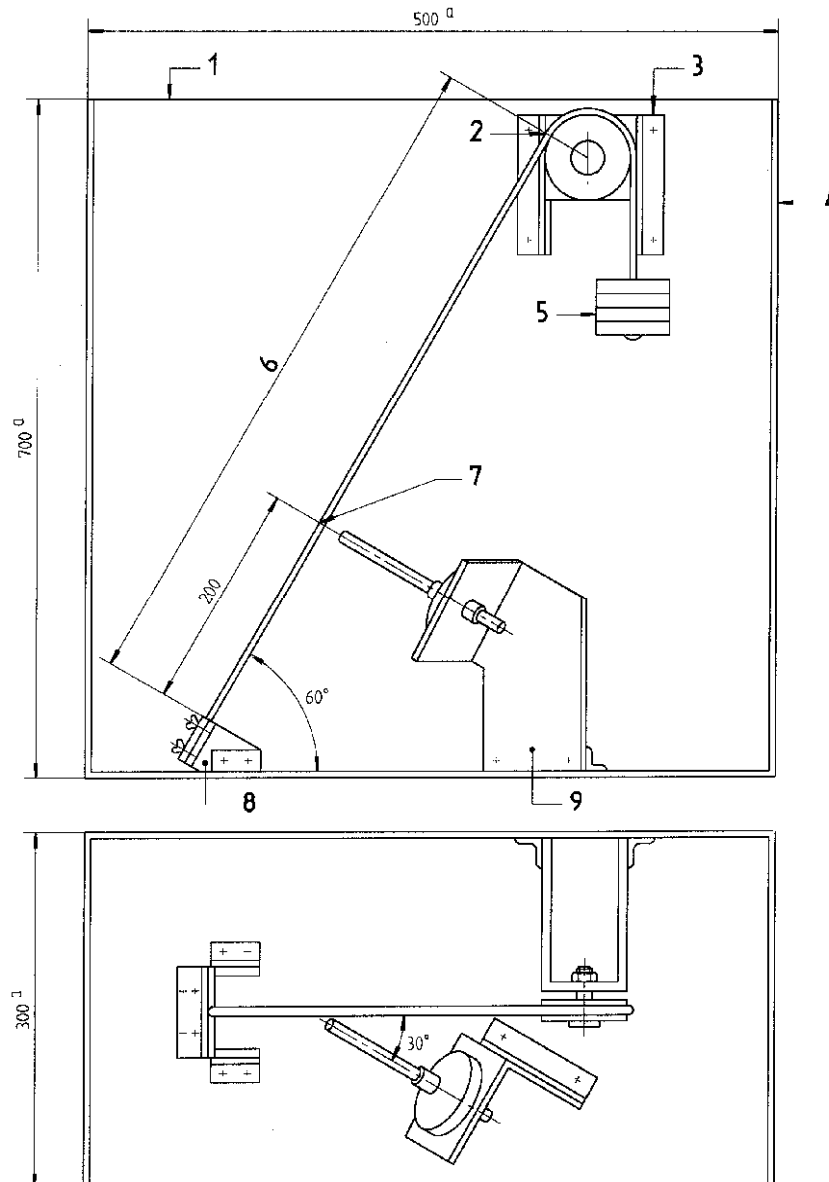

Key

- | | |
|---|--|
| 1 Box construction aluminium alloy 3,15 mm | 6 600 - Distance between reference marks |
| 2 Upper datum point | 7 Flame application point (flame centre datum) |
| 3 Pulley support bracket (low thermal conductivity) | 8 Bottom clamp support (low thermal conductivity) |
| 4 Support frame open at front | 9 Bunsen burner support (low thermal conductivity) |
| 5 Weights as required | |

^a approx.

Figure 1 — Mounting configuration

4.1.3.2 Make a mark 200 mm above the lower clamp point and position the burner in the plane of this mark, perpendicular to the specimen and directed towards the specimen at an angle of 30° to the vertical plane as shown in Figure 1, i.e. at 90° to the axis of the cable such that the flame will impinge directly onto the 200 mm mark.

4.1.3.3 Set the distance of the burner from the specimen such that the tip of the inner cone of the flame is immediately below the specimen.

4.1.4 Flame application

Apply the flame to each specimen of a set for a period of 15 s and then immediately remove the burner. Apply the flame to each specimen of the second set for a period of 30 s and then immediately remove the burner.

NOTE 1 For thin wall insulation the time of 15 s is considered more severe, as all the insulation can be carbonized in less than 30 s.

NOTE 2 Nevertheless a test at 30 s is also necessary to assess FAR/JAR 25 requirements.

NOTE 3 The 15 s value was introduced in P2 issue when 30 s value was initially removed.

4.2 Method 2

4.2.1 Preparation of test specimens

Cut three specimens, approximately 450 mm in length, consecutively from the same coil. Strip each end and place them in an atmosphere of (50 ± 5) % relative humidity at a temperature of (21 ± 3) °C for a period of not less than 24 h. Keep the specimens in the conditioning area until just prior to testing. Remove 50 mm of insulation from one end of the specimen and mount it as shown in Figure 2.

4.2.2 Flame temperature

Adjust the Bunsen burner to produce a 38 mm high soft yellow flame.

4.2.3 Mounting configuration

Mount the specimen vertically in the test chamber as shown in Figure 2. Fix the lower end of the conductor to the support bar and apply the fine wire to the conductor at the junction with the insulation. Pass the cable over the upper pulley and attach it to a weight which is just sufficient to keep the specimen straight within the test zone.

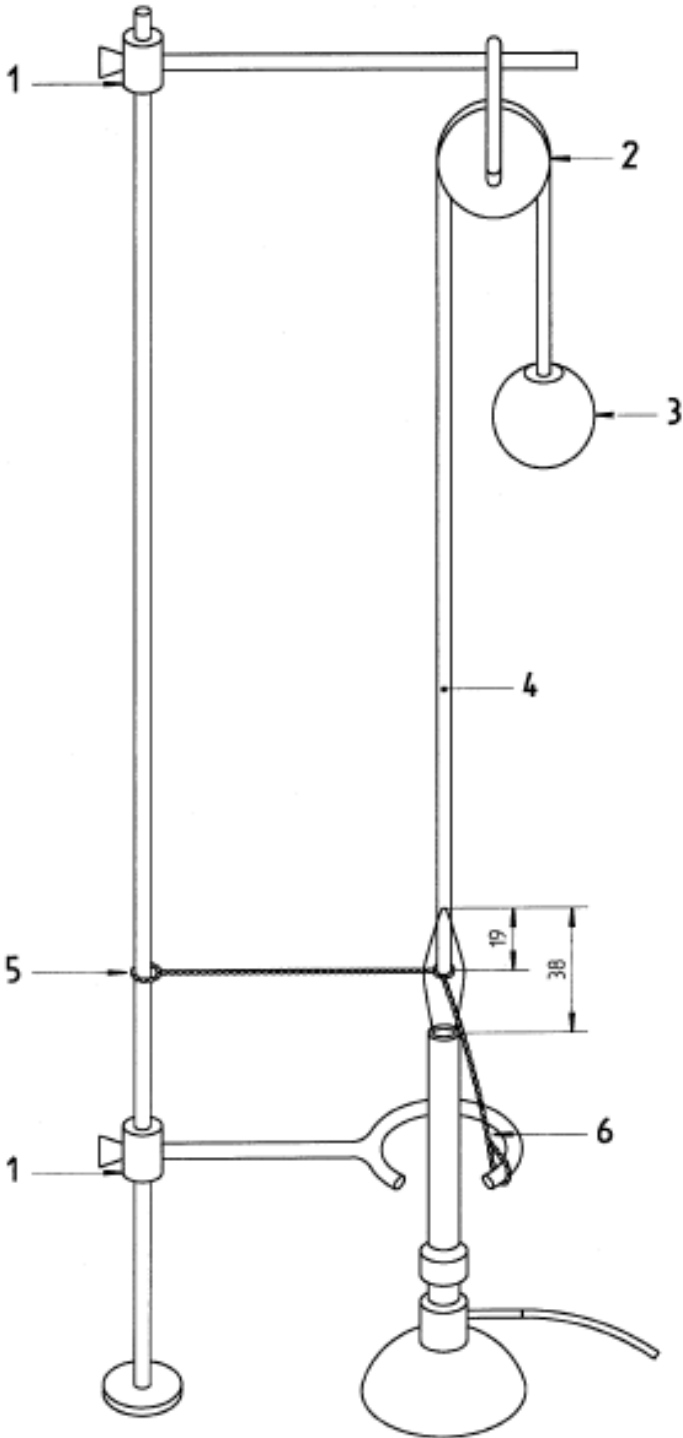

Key

- 1 Clamp
- 2 Pulley
- 3 Weight
- 4 Specimen
- 5 Fine wire
- 6 Stripped conductor 50 mm

Figure 1 — Alternative mounting configuration

Apply the 38 mm high yellow flame from the Bunsen burner to the specimen at the junction of the insulation and the bare conductor in such a manner that the lower end of the insulation is located half-way (19 mm) into the flame as shown in Figure 2.

4.2.4 Flame application

Apply the flame to the specimen for a period of 15 s and then immediately remove the burner.

4.3 Completion of test (methods 1 and 2)

4.3.1 After the burner has been removed, note the time taken for all flaming of the specimen to cease and the length of specimen cable which has been burnt.

4.3.2 Repeat the procedure for the two other specimens.

5 Acceptance criteria

5.1 Method 1

During ignition and combustion, there shall be no flaming droplets or particles falling from the specimen. After the burner has been removed, the specimen cable shall cease flaming within the time specified in the product standard and within a total burnt length of 50 mm. The burn length shall be measured from the downward extent of propagation to the upward extent of propagation and including damage caused by the burner itself.

5.2 Method 2

During the test, there shall be no flaming droplets or particles falling from the specimen. After the burner has been removed, the specimen cable shall cease flaming within 10 s and within a total burnt or charred length of 75 mm. The burnt length is the distance from the original junction of the insulation and the bare conductor, indicated by the bend made in the conductor, to the farthest point of damage.

NOTE Where a product standard specifies only one burn time, this shall be taken as referring to method 1.

BSI - British Standards Institution

BSI is the independent national body responsible for preparing British Standards. It presents the UK view on standards in Europe and at the international level. It is incorporated by Royal Charter.

Revisions

British Standards are updated by amendment or revision. Users of British Standards should make sure that they possess the latest amendments or editions.

It is the constant aim of BSI to improve the quality of our products and services. We would be grateful if anyone finding an inaccuracy or ambiguity while using this British Standard would inform the Secretary of the technical committee responsible, the identity of which can be found on the inside front cover. Tel: +44 (0)20 8996 9000. Fax: +44 (0)20 8996 7400.

BSI offers members an individual updating service called PLUS which ensures that subscribers automatically receive the latest editions of standards.

Buying standards

Orders for all BSI, international and foreign standards publications should be addressed to Customer Services. Tel: +44 (0)20 8996 9001. Fax: +44 (0)20 8996 7001 Email: orders@bsigroup.com You may also buy directly using a debit/credit card from the BSI Shop on the Website <http://www.bsigroup.com/shop>

In response to orders for international standards, it is BSI policy to supply the BSI implementation of those that have been published as British Standards, unless otherwise requested.

Information on standards

BSI provides a wide range of information on national, European and international standards through its Library and its Technical Help to Exporters Service. Various BSI electronic information services are also available which give details on all its products and services. Contact Information Centre. Tel: +44 (0)20 8996 7111 Fax: +44 (0)20 8996 7048 Email: info@bsigroup.com

Subscribing members of BSI are kept up to date with standards developments and receive substantial discounts on the purchase price of standards. For details of these and other benefits contact Membership Administration. Tel: +44 (0)20 8996 7002 Fax: +44 (0)20 8996 7001 Email: membership@bsigroup.com

Information regarding online access to British Standards via British Standards Online can be found at <http://www.bsigroup.com/BSOL>

Further information about BSI is available on the BSI website at <http://www.bsigroup.com>.

Copyright

Copyright subsists in all BSI publications. BSI also holds the copyright, in the UK, of the publications of the international standardization bodies. Except as permitted under the Copyright, Designs and Patents Act 1988 no extract may be reproduced, stored in a retrieval system or transmitted in any form or by any means – electronic, photocopying, recording or otherwise – without prior written permission from BSI.

This does not preclude the free use, in the course of implementing the standard, of necessary details such as symbols, and size, type or grade designations. If these details are to be used for any other purpose than implementation then the prior written permission of BSI must be obtained.

Details and advice can be obtained from the Copyright and Licensing Manager. Tel: +44 (0)20 8996 7070 Email: copyright@bsigroup.com