

BS EN 3268:2014



BSI Standards Publication

Aerospace series — Pipe coupling 8°30' in titanium alloy — Pressure plugs

bsi.

...making excellence a habit.™

National foreword

This British Standard is the UK implementation of EN 3268:2014. It supersedes BS EN 3268:2001 which is withdrawn.

The UK participation in its preparation was entrusted to Technical Committee ACE/69, Aerospace hydraulic systems, fluids and components.

A list of organizations represented on this committee can be obtained on request to its secretary.

This publication does not purport to include all the necessary provisions of a contract. Users are responsible for its correct application.

© The British Standards Institution 2014. Published by BSI Standards Limited 2014

ISBN 978 0 580 67365 8

ICS 49.080

Compliance with a British Standard cannot confer immunity from legal obligations.

This British Standard was published under the authority of the Standards Policy and Strategy Committee on 31 October 2014.

Amendments issued since publication

Date	Text affected
------	---------------

EUROPEAN STANDARD

EN 3268

NORME EUROPÉENNE

EUROPÄISCHE NORM

October 2014

ICS 49.080

Supersedes EN 3268:2001

English Version

**Aerospace series - Pipe coupling 8°30' in titanium alloy -
Pressure plugs**Série aérospatiale - Système de raccordement 8°30' en
alliage de titane - Obturateurs de tuyauterieLuft- und Raumfahrt - Rohrverschraubung 8°30' aus
Titanlegierung - Blindverschraubungen

This European Standard was approved by CEN on 4 January 2014.

CEN members are bound to comply with the CEN/CENELEC Internal Regulations which stipulate the conditions for giving this European Standard the status of a national standard without any alteration. Up-to-date lists and bibliographical references concerning such national standards may be obtained on application to the CEN-CENELEC Management Centre or to any CEN member.

This European Standard exists in three official versions (English, French, German). A version in any other language made by translation under the responsibility of a CEN member into its own language and notified to the CEN-CENELEC Management Centre has the same status as the official versions.

CEN members are the national standards bodies of Austria, Belgium, Bulgaria, Croatia, Cyprus, Czech Republic, Denmark, Estonia, Finland, Former Yugoslav Republic of Macedonia, France, Germany, Greece, Hungary, Iceland, Ireland, Italy, Latvia, Lithuania, Luxembourg, Malta, Netherlands, Norway, Poland, Portugal, Romania, Slovakia, Slovenia, Spain, Sweden, Switzerland, Turkey and United Kingdom.

EUROPEAN COMMITTEE FOR STANDARDIZATION
COMITÉ EUROPÉEN DE NORMALISATION
EUROPÄISCHES KOMITEE FÜR NORMUNG**CEN-CENELEC Management Centre: Avenue Marnix 17, B-1000 Brussels**

Contents		Page
Foreword.....		3
1	Scope	4
2	Normative references	4
3	Required characteristics.....	4
3.1	Configuration – Dimensions – Mass.....	4
3.2	Surface roughness	4
3.3	Materials	4
3.4	Surface treatment	4
4	Designation	6
5	Marking	7
6	Technical specification	7
Annex A (informative) Standard evolution form		8

Foreword

This document (EN 3268:2014) has been prepared by the Aerospace and Defence Industries Association of Europe - Standardization (ASD-STAN).

After enquiries and votes carried out in accordance with the rules of this Association, this Standard has received the approval of the National Associations and the Official Services of the member countries of ASD, prior to its presentation to CEN.

This European Standard shall be given the status of a national standard, either by publication of an identical text or by endorsement, at the latest by April 2015, and conflicting national standards shall be withdrawn at the latest by April 2015.

Attention is drawn to the possibility that some of the elements of this document may be the subject of patent rights. CEN [and/or CENELEC] shall not be held responsible for identifying any or all such patent rights.

This document supersedes EN 3268:2001.

According to the CEN-CENELEC Internal Regulations, the national standards organizations of the following countries are bound to implement this European Standard: Austria, Belgium, Bulgaria, Croatia, Cyprus, Czech Republic, Denmark, Estonia, Finland, Former Yugoslav Republic of Macedonia, France, Germany, Greece, Hungary, Iceland, Ireland, Italy, Latvia, Lithuania, Luxembourg, Malta, Netherlands, Norway, Poland, Portugal, Romania, Slovakia, Slovenia, Spain, Sweden, Switzerland, Turkey and the United Kingdom.

1 Scope

This European Standard specifies the characteristics of pressure plugs for pipe couplings 8°30', in titanium alloy, for aerospace applications.

2 Normative references

The following documents, in whole or in part, are normatively referenced in this document and are indispensable for its application. For dated references, only the edition cited applies. For undated references, the latest edition of the referenced document (including any amendments) applies.

EN 2424, *Aerospace series - Marking of aerospace products*

EN 2491, *Aerospace series - Molybdenum disulphide dry lubricants - Coating methods*

EN 3274, *Aerospace series - Pipe coupling 8°30' - Thread end - Geometric configuration*

EN 3275, *Aerospace series - Pipe coupling 8°30' up to 28 000 kPa - Dynamic beam seal - Metric series - Technical specification*

EN 3311, *Aerospace series - Titanium alloy TI-P64001 (Ti-6Al-4V) - Annealed - Bar for machining - D < 110 mm*

EN 3314, *Aerospace series - Titanium alloy TI-P64001 - Solution treated and aged - Bar for machining - D ≤ 75 mm* ¹⁾

ISO 5855-3, *Aerospace - MJ threads - Part 3: Limit dimensions for fittings for fluid systems*

MIL-PRF-24635, *Performance specification - Coating systems, weather resistant, exterior use* ²⁾

FED-STD-595, *Federal Standard: colors used in government procurement (Color FS 11136)* ²⁾

3 Required characteristics

3.1 Configuration – Dimensions – Mass

According to Figure 1 and Table 1.

Dimensions applied before lubricating.

3.2 Surface roughness

According to Figure 1.

3.3 Materials

According to EN 3311 or EN 3314.

3.4 Surface treatment

Lubrication: according to EN 2491 on thread and sealing face, film thickness: 0.005 mm to 0.013mm.

1) Published as ASD-STAN Prestandard at the date of publication of this standard (www.asd-stan.org).

2) Published by: DoD National (US) Mil. Department of Defense (<http://www.defenselink.mil/>).

Optional, red coating FED-STD-595/11136 in accordance with MIL-PRF-24635 (see Figure 1 and Table 2).

Prior to application of lubricant or coating, the surface shall be abrasive blasted using non-metallic grit.

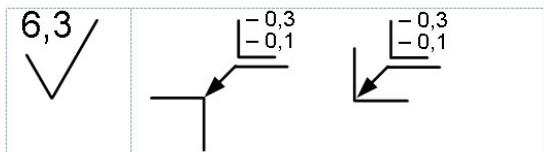

Dimensions in millimetres

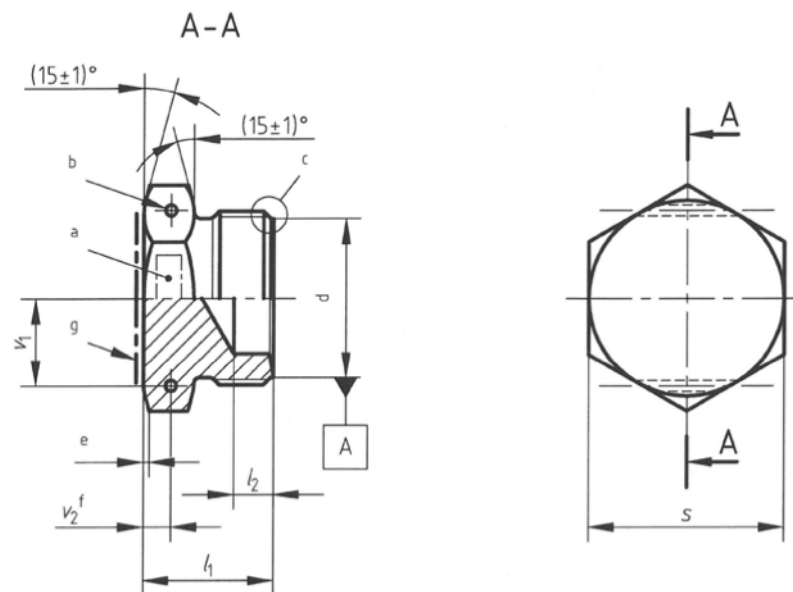

Key

- a Area for marking
- b Two holes $\varnothing d_1$ (optional, see Table 1)
- c According to EN 3274, form B
- d Thread
- e 0,3 to 0,6 applicable to both faces
- f From either face
- g Red coating zone (optional, see Table 2)

Figure 1

Table 1

Dimensions in millimetres

Code a	Thread b 4g6g	d_1 H13	l_1 $\pm 0,2$	l_2 $\pm 0,4$	s h13	v_1 $\pm 0,2$	v_2 min.	Mass g/piece	
									max.
05	MJ10×1	1	11,3	5,6	11	4,21	2,1	1,96	
06	MJ12×1,25	1,5	13,5	7,1	13	4,94	2,6	3,04	
08	MJ14×1,5		15,8	8,4	16	6,54	3,1	5,92	
10	MJ16×1,5		16,3	7,8	17	6,9	3,6	6,80	
12	MJ18×1,5		16,8	7,3	19	7,97	3,85	10,15	
14	MJ20×1,5		17,3	7	22	9,68		13,57	
16	MJ22×1,5		17,8	6,5	24	10,51		17,75	
18	MJ24×1,5			5,9	27	12,11		23,00	
20	MJ27×1,5		18,2	5,1	30	13,77		31,01	
22	MJ30×1,5		18,3	4,3	32	14,76	37,70		
25	MJ33×1,5			3,9	34	15,66	43,35		
28	MJ36×1,5		18,8	2,9	41	19,56	4,6	66,70	
32	MJ39×1,5			2,1				71,81	

^a Corresponds to the pipe nominal outside diameter.
^b According to ISO 5855-3.

4 Designation

EXAMPLE

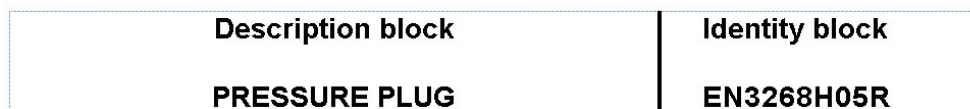

NOTE If necessary, the code I9005 shall be placed between the description block and the identity block.

Table 2

Option	Code
Lockwire hole	H
No hole	– (hyphen)
Red coating	R
No red coating	No code

5 Marking

According to EN 2424, style A and Figure 1.

WARNING — Items marked with red colour reference are NON-FLIGHTWORTHY COMPONENTS and must be REMOVED BEFORE FLIGHT.

6 Technical specification

According to EN 3275.

Annex A
(informative)

Standard evolution form

MODIFICATION	REASON AND VALIDATION
Before: Federal Standard 595B After: Federal Standard 595	For the "Red" Colour code the standard number for the Federal Standard 595 B was changed to 595.
Typing error: MJ18 × 1,8 must read MJ18 × 1,5 this is a standard ISO thread	The Letter "B" indicates the published version. We do not quote the "issues" of ref standards. The colour code 11136 was added.
Additional information in the Standard: Optional code "R" be careful this component shall not be used in flight condition.	Was added on the standard.

British Standards Institution (BSI)

BSI is the national body responsible for preparing British Standards and other standards-related publications, information and services.

BSI is incorporated by Royal Charter. British Standards and other standardization products are published by BSI Standards Limited.

About us

We bring together business, industry, government, consumers, innovators and others to shape their combined experience and expertise into standards-based solutions.

The knowledge embodied in our standards has been carefully assembled in a dependable format and refined through our open consultation process. Organizations of all sizes and across all sectors choose standards to help them achieve their goals.

Information on standards

We can provide you with the knowledge that your organization needs to succeed. Find out more about British Standards by visiting our website at bsigroup.com/standards or contacting our Customer Services team or Knowledge Centre.

Buying standards

You can buy and download PDF versions of BSI publications, including British and adopted European and international standards, through our website at bsigroup.com/shop, where hard copies can also be purchased.

If you need international and foreign standards from other Standards Development Organizations, hard copies can be ordered from our Customer Services team.

Subscriptions

Our range of subscription services are designed to make using standards easier for you. For further information on our subscription products go to bsigroup.com/subscriptions.

With **British Standards Online (BSOL)** you'll have instant access to over 55,000 British and adopted European and international standards from your desktop. It's available 24/7 and is refreshed daily so you'll always be up to date.

You can keep in touch with standards developments and receive substantial discounts on the purchase price of standards, both in single copy and subscription format, by becoming a **BSI Subscribing Member**.

PLUS is an updating service exclusive to BSI Subscribing Members. You will automatically receive the latest hard copy of your standards when they're revised or replaced.

To find out more about becoming a BSI Subscribing Member and the benefits of membership, please visit bsigroup.com/shop.

With a **Multi-User Network Licence (MUNL)** you are able to host standards publications on your intranet. Licences can cover as few or as many users as you wish. With updates supplied as soon as they're available, you can be sure your documentation is current. For further information, email bsmusales@bsigroup.com.

BSI Group Headquarters

389 Chiswick High Road London W4 4AL UK

Revisions

Our British Standards and other publications are updated by amendment or revision.

We continually improve the quality of our products and services to benefit your business. If you find an inaccuracy or ambiguity within a British Standard or other BSI publication please inform the Knowledge Centre.

Copyright

All the data, software and documentation set out in all British Standards and other BSI publications are the property of and copyrighted by BSI, or some person or entity that owns copyright in the information used (such as the international standardization bodies) and has formally licensed such information to BSI for commercial publication and use. Except as permitted under the Copyright, Designs and Patents Act 1988 no extract may be reproduced, stored in a retrieval system or transmitted in any form or by any means – electronic, photocopying, recording or otherwise – without prior written permission from BSI. Details and advice can be obtained from the Copyright & Licensing Department.

Useful Contacts:

Customer Services

Tel: +44 845 086 9001

Email (orders): orders@bsigroup.com

Email (enquiries): cservices@bsigroup.com

Subscriptions

Tel: +44 845 086 9001

Email: subscriptions@bsigroup.com

Knowledge Centre

Tel: +44 20 8996 7004

Email: knowledgecentre@bsigroup.com

Copyright & Licensing

Tel: +44 20 8996 7070

Email: copyright@bsigroup.com



...making excellence a habit.™