

BS EN 3264:2010



BSI Standards Publication

# Aerospace series — Pipe coupling 8°30' in titanium alloy — Thrust wire nuts

NO COPYING WITHOUT BSI PERMISSION EXCEPT AS PERMITTED BY COPYRIGHT LAW

*raising standards worldwide*™

Provided by IHS  
No reproduction or networking permitted without license from IHS

Not for Resale



**National foreword**

This British Standard is the UK implementation of EN 3264:2010. It supersedes BS EN 3264:2001, which is withdrawn.

The UK participation in its preparation was entrusted to Technical Committee ACE/12, Aerospace fasteners and fastening systems.

A list of organizations represented on this committee can be obtained on request to its secretary.

This publication does not purport to include all the necessary provisions of a contract. Users are responsible for its correct application.

© BSI 2010

ISBN 978 0 580 65876 1

ICS 49.080

**Compliance with a British Standard cannot confer immunity from legal obligations.**

This British Standard was published under the authority of the Standards Policy and Strategy Committee on 31 July 2010

**Amendments issued since publication**

Date	Text affected
------	---------------

---

English Version

**Aerospace series - Pipe coupling 8°30' in titanium alloy - Thrust  
wire nuts**Série aérospatiale - Système de raccordement 8°30' en  
alliage de titane - Écrous à joncLuft- und Raumfahrt - Rohrverschraubung 8°30' aus  
Titanlegierung - Muttern mit Schubdraht

This European Standard was approved by CEN on 26 May 2010.

CEN members are bound to comply with the CEN/CENELEC Internal Regulations which stipulate the conditions for giving this European Standard the status of a national standard without any alteration. Up-to-date lists and bibliographical references concerning such national standards may be obtained on application to the CEN Management Centre or to any CEN member.

This European Standard exists in three official versions (English, French, German). A version in any other language made by translation under the responsibility of a CEN member into its own language and notified to the CEN Management Centre has the same status as the official versions.

CEN members are the national standards bodies of Austria, Belgium, Bulgaria, Croatia, Cyprus, Czech Republic, Denmark, Estonia, Finland, France, Germany, Greece, Hungary, Iceland, Ireland, Italy, Latvia, Lithuania, Luxembourg, Malta, Netherlands, Norway, Poland, Portugal, Romania, Slovakia, Slovenia, Spain, Sweden, Switzerland and United Kingdom.

EUROPEAN COMMITTEE FOR STANDARDIZATION  
COMITÉ EUROPÉEN DE NORMALISATION  
EUROPÄISCHES KOMITEE FÜR NORMUNG**Management Centre: Avenue Marnix 17, B-1000 Brussels**

## Contents

Page

Foreword.....	3
1 <b>Scope</b> .....	4
2 <b>Normative references</b> .....	4
3 <b>Required characteristics</b> .....	4
4 <b>Designation</b> .....	6
5 <b>Marking</b> .....	7
6 <b>Technical specification</b> .....	7
7 <b>Qualification</b> .....	7

## Foreword

This document (EN 3264:2010) has been prepared by the Aerospace and Defence Industries Association of Europe - Standardization (ASD-STAN).

After enquiries and votes carried out in accordance with the rules of this Association, this Standard has received the approval of the National Associations and the Official Services of the member countries of ASD, prior to its presentation to CEN.

This European Standard shall be given the status of a national standard, either by publication of an identical text or by endorsement, at the latest by January 2010, and conflicting national standards shall be withdrawn at the latest by January 2010.

Attention is drawn to the possibility that some of the elements of this document may be the subject of patent rights. CEN [and/or CENELEC] shall not be held responsible for identifying any or all such patent rights.

This document supersedes EN 3264:2001.

According to the CEN/CENELEC Internal Regulations, the national standards organizations of the following countries are bound to implement this European Standard: Austria, Belgium, Bulgaria, Croatia, Cyprus, Czech Republic, Denmark, Estonia, Finland, France, Germany, Greece, Hungary, Iceland, Ireland, Italy, Latvia, Lithuania, Luxembourg, Malta, Netherlands, Norway, Poland, Portugal, Romania, Slovakia, Slovenia, Spain, Sweden, Switzerland and the United Kingdom.

.....

## 1 Scope

This European Standard specifies the characteristics of thrust wire nuts for pipe couplings 8°30', in titanium alloy, for aerospace applications.

Nominal pressure: up to 28 000 kPa

Temperature range: – 55 °C to 135 °C

## 2 Normative references

The following referenced documents are indispensable for the application of this document. For dated references, only the edition cited applies. For undated references, the latest edition of the referenced document (including any amendments) applies.

EN 2424, *Aerospace series — Marking of aerospace products*

EN 2491, *Aerospace series — Molybdenum disulphide dry lubricants — Coating methods*

EN 3275, *Aerospace series — Pipe coupling 8°30' up to 28 000 kPa — Dynamic beam seal — Metric series — Technical specification*

EN 3311, *Aerospace series — Titanium alloy TI-P64001 (Ti-6Al-4V) — Annealed — Bar for machining — D ≤ 110 mm*

EN 3314, *Aerospace series — Titanium alloy TI-P64001 — Solution treated and aged — Bar for machining — D ≤ 75 mm<sup>1)</sup>*

EN 4032, *Aerospace series — Pipe coupling 8°30' in titanium alloy — Thrust wire*

EN 9133, *Aerospace series — Quality management systems — Qualification procedure for aerospace standard parts*

ISO 5855-3, *Aerospace — MJ threads — Part 3: Limit dimensions for fittings for fluid systems*

ISO 8788, *Aerospace — Nuts, metric — Tolerances of form and position*

## 3 Required characteristics

### 3.1 Configuration – Dimensions – Mass

According to Figure 1 and Table 1. The values apply before lubricating.

### 3.2 Surface roughness

According to Figure 1.

---

1) Published as ASD-STAN Prestandard at the date of publication of this standard by Aerospace and Defence Industries Association of Europe-Standardization (ASD-STAN), ([www.asd-stan.org](http://www.asd-stan.org)).

### 3.3 Material

According to EN 3311 or EN 3314

### 3.4 Surface treatment

Lubrication: according to EN 2491, on the bottom of the groove only.

Prior to application of the lubricant the surface shall be abrasive blasted using non-metallic grit.

Film thickness: 0,005 mm to 0,013 mm

Dimensions in millimetres

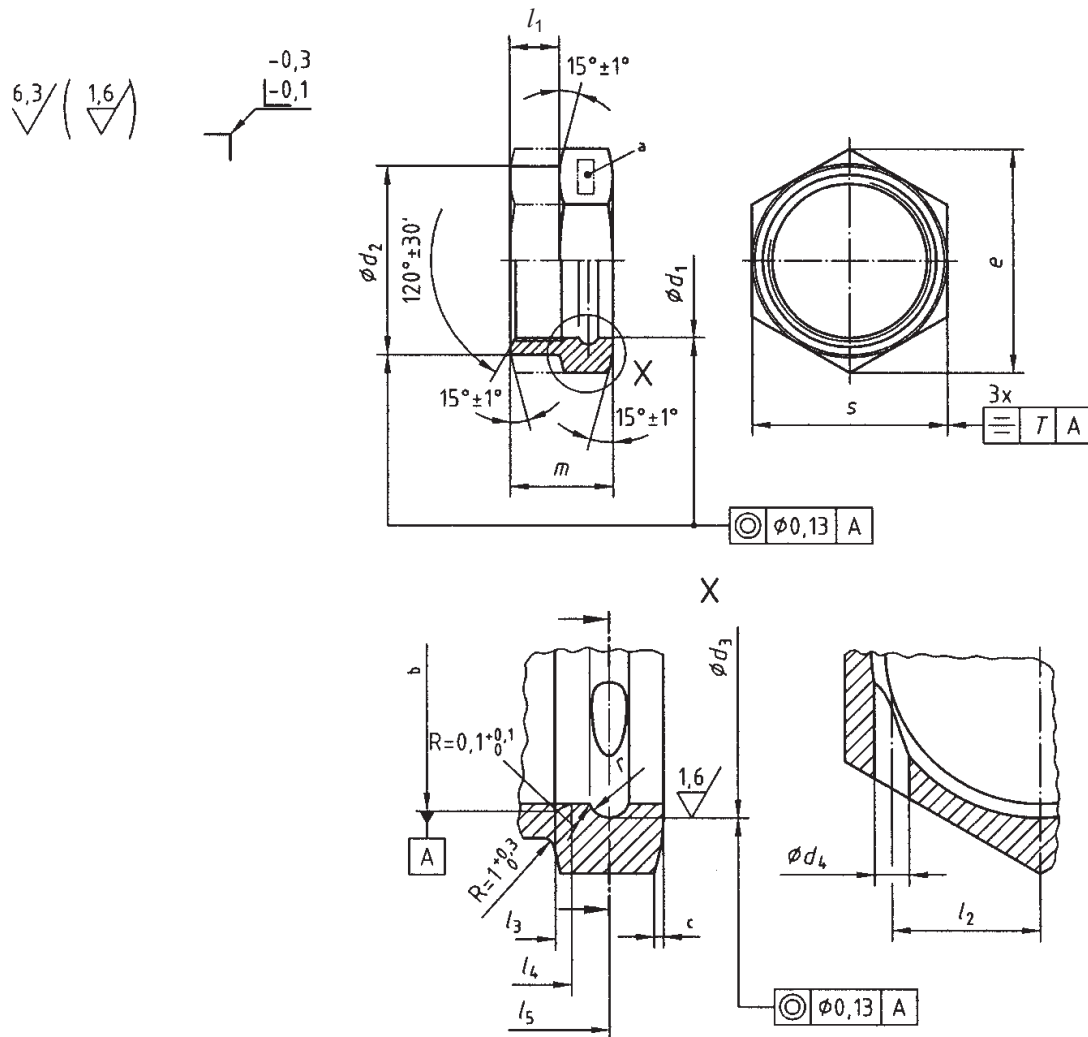

- a Area for marking
- b Thread
- c 0,3 to 0,5 applicable to both faces

Figure 1

Table 1

Dimensions in millimetres

Code <sup>a</sup>	Thread <sup>b</sup> 4H5H	$d_1$ $\pm 0,1$	$d_2$ $\begin{matrix} 0 \\ -0,2 \end{matrix}$	$d_3$ $\begin{matrix} +0,1 \\ 0 \end{matrix}$	$d_4^c$ $\begin{matrix} +0,1 \\ 0 \end{matrix}$	$e$ min.	$l_1$ $\pm 0,4$	$l_2$ $\pm 0,1$	$l_3^d$	$l_4$ max.	$l_5$ $\pm 0,1$	$m$ h11	$r$ $\begin{matrix} +0,1 \\ 0 \end{matrix}$	$s$ h13	$T^e$	Mass g/piece max.	
05	MJ10 × 1	9,1	–	11,0	2,2	15,51	–	4,2	7,2	8,4	10,0	13,0	1,3	14	0,36	5,52	
06	MJ12 × 1,25	10,8	–	12,6		17,77	–	5,2	8,0	9,2	11,0	14,0		16	0,43	7,36	
08	MJ14 × 1,5	12,6	17,0	14,6		20,03	11,0	6,2	9,5	11,0	13,0	16,0		18			9,00
10	MJ16 × 1,5	14,6	19,0	16,6		23,36	10,5	7,2	14,0	16,5	21	10,64					
12	MJ18 × 1,5	16,6	21,0	19,2	24,49	8,2		17,5		22							
14	MJ20 × 1,5	18,6	23,0	21,2	2,7	26,75	9,2	18,0	1,6	24	11,56						
16	MJ22 × 1,5	20,6	26,0	23,2		30,14	10,2	27	17,50								
18	MJ24 × 1,5	22,6	28,0	25,2	3,2	33,53	10,0	11,2		10,5	12,0	19,0	1,9	30	0,52	23,66	
20	MJ27 × 1,5	25,6	31,0	28,2		35,72		12,5	32								23,23
22	MJ30 × 1,5	28,6	35,0	31,2		39,98		13,7	36								
25	MJ33 × 1,5	31,6	38,0	34,2	45,63	9,5	15,5	14,5	19,5	41	36,63						
28	MJ36 × 1,5	34,6	41,0	37,2	51,28		17,2					46	0,62	42,00			
32	MJ39 × 1,5	37,6	45,0	40,2	55,80		18,6								50	51,45	

<sup>a</sup> Corresponds to the pipe nominal outside diameter.

<sup>b</sup> According to ISO 5855-3.

<sup>c</sup> Corresponding wire diameter according to EN 4032.

<sup>d</sup> Minimum usable thread length.

<sup>e</sup> According to ISO 8788.

## 4 Designation

EXAMPLE

<p><b>Description block</b></p> <p><b>THRUST WIRE NUT</b></p>		<p><b>Identity block</b></p> <p><b>EN3264-05</b></p>
---	--	--

Number of this standard \_\_\_\_\_

Code (see Table 1) \_\_\_\_\_

NOTE If necessary, the code I9005 shall be placed between the description block and the identity block.



## **5 Marking**

According to EN 2424, style A and Figure 1.

## **6 Technical specification**

According to EN 3275, type II.

## **7 Qualification**

According to EN 9133.

www.pearson.com

*This page deliberately left blank*

.....

*This page deliberately left blank*

# British Standards Institution (BSI)

BSI is the independent national body responsible for preparing British Standards and other standards-related publications, information and services.

It presents the UK view on standards in Europe and at the international level.

It is incorporated by Royal Charter.

## Revisions

British Standards are updated by amendment or revision. Users of British Standards should make sure that they possess the latest amendments or editions.

It is the constant aim of BSI to improve the quality of our products and services. We would be grateful if anyone finding an inaccuracy or ambiguity while using this British Standard would inform the Secretary of the technical committee responsible, the identity of which can be found on the inside front cover.

**Tel: +44 (0)20 8996 9001 Fax: +44 (0)20 8996 7001**

BSI offers Members an individual updating service called PLUS which ensures that subscribers automatically receive the latest editions of standards.

**Tel: +44 (0)20 8996 7669 Fax: +44 (0)20 8996 7001**

**Email: [plus@bsigroup.com](mailto:plus@bsigroup.com)**

## Buying standards

You may buy PDF and hard copy versions of standards directly using a credit card from the BSI Shop on the website [www.bsigroup.com/shop](http://www.bsigroup.com/shop). In addition all orders for BSI, international and foreign standards publications can be addressed to BSI Customer Services.

**Tel: +44 (0)20 8996 9001 Fax: +44 (0)20 8996 7001**

**Email: [orders@bsigroup.com](mailto:orders@bsigroup.com)**

In response to orders for international standards, it is BSI policy to supply the BSI implementation of those that have been published as British Standards, unless otherwise requested.

## Information on standards

BSI provides a wide range of information on national, European and international standards through its Knowledge Centre.

**Tel: +44 (0)20 8996 7004 Fax: +44 (0)20 8996 7005**

**Email: [knowledgecentre@bsigroup.com](mailto:knowledgecentre@bsigroup.com)**

Various BSI electronic information services are also available which give details on all its products and services.

**Tel: +44 (0)20 8996 7111 Fax: +44 (0)20 8996 7048**

**Email: [info@bsigroup.com](mailto:info@bsigroup.com)**

BSI Subscribing Members are kept up to date with standards developments and receive substantial discounts on the purchase price of standards. For details of these and other benefits contact Membership Administration.

**Tel: +44 (0)20 8996 7002 Fax: +44 (0)20 8996 7001**

**Email: [membership@bsigroup.com](mailto:membership@bsigroup.com)**

Information regarding online access to British Standards via British Standards Online can be found at [www.bsigroup.com/BSOL](http://www.bsigroup.com/BSOL)

Further information about BSI is available on the BSI website at [www.bsigroup.com/standards](http://www.bsigroup.com/standards)

## Copyright

Copyright subsists in all BSI publications. BSI also holds the copyright, in the UK, of the publications of the international standardization bodies. Except as permitted under the Copyright, Designs and Patents Act 1988 no extract may be reproduced, stored in a retrieval system or transmitted in any form or by any means – electronic, photocopying, recording or otherwise – without prior written permission from BSI. This does not preclude the free use, in the course of implementing the standard of necessary details such as symbols, and size, type or grade designations. If these details are to be used for any other purpose than implementation then the prior written permission of BSI must be obtained. Details and advice can be obtained from the Copyright & Licensing Manager.

**Tel: +44 (0)20 8996 7070**

**Email: [copyright@bsigroup.com](mailto:copyright@bsigroup.com)**

## BSI Group Headquarters

389 Chiswick High Road London W4 4AL UK

Tel +44 (0)20 8996 9001

Fax +44 (0)20 8996 7001

[www.bsigroup.com/standards](http://www.bsigroup.com/standards)

*raising standards worldwide™*