



BSI Standards Publication

**Aerospace series — Nuts,
anchor, self-locking, air
resistant, sealing, floating,
two lug, with counterbore,
in corrosion resisting steel,
passivated, MoS2 lubricated
— Classification: 900 MPa (at
ambient temperature) / 235 °C**

National foreword

This British Standard is the UK implementation of EN 2879:2017.

The UK participation in its preparation was entrusted to Technical Committee ACE/12, Aerospace fasteners and fastening systems.

A list of organizations represented on this committee can be obtained on request to its secretary.

This publication does not purport to include all the necessary provisions of a contract. Users are responsible for its correct application.

© The British Standards Institution 2017.
Published by BSI Standards Limited 2017

ISBN 978 0 580 92611 2

ICS 49.030.30

Compliance with a British Standard cannot confer immunity from legal obligations.

This British Standard was published under the authority of the Standards Policy and Strategy Committee on 31 January 2017.

Amendments/corrigenda issued since publication

Date	Text affected
------	---------------

EUROPEAN STANDARD

EN 2879

NORME EUROPÉENNE

EUROPÄISCHE NORM

January 2017

ICS 49.030.30

English Version

Aerospace series - Nuts, anchor, self-locking, air resistant, sealing, floating, two lug, with counterbore, in corrosion resisting steel, passivated, MoS2 lubricated - Classification: 900 MPa (at ambient temperature) / 235 °C

Série aérospatiale - Écrous à river, à freinage interne, étanches à l'air, flottants, double patte, avec chambrage, en acier résistant à la corrosion, passivés, lubrifiés MoS2 - Classification : 900 MPa (à température ambiante) / 235 °C

Luft- und Raumfahrt - Anniemuttern, selbstsichernd, luftbeständig, druckdicht, beweglich, beiderseitiger Flansch, mit zylindrischer Aussenkung, aus korrosionsbeständigem Stahl, passiviert, MoS2-geschmiert - Klasse: 900 MPa (bei Raumtemperatur)/235 °C

This European Standard was approved by CEN on 4 March 2016.

CEN members are bound to comply with the CEN/CENELEC Internal Regulations which stipulate the conditions for giving this European Standard the status of a national standard without any alteration. Up-to-date lists and bibliographical references concerning such national standards may be obtained on application to the CEN-CENELEC Management Centre or to any CEN member.

This European Standard exists in three official versions (English, French, German). A version in any other language made by translation under the responsibility of a CEN member into its own language and notified to the CEN-CENELEC Management Centre has the same status as the official versions.

CEN members are the national standards bodies of Austria, Belgium, Bulgaria, Croatia, Cyprus, Czech Republic, Denmark, Estonia, Finland, Former Yugoslav Republic of Macedonia, France, Germany, Greece, Hungary, Iceland, Ireland, Italy, Latvia, Lithuania, Luxembourg, Malta, Netherlands, Norway, Poland, Portugal, Romania, Serbia, Slovakia, Slovenia, Spain, Sweden, Switzerland, Turkey and United Kingdom.



EUROPEAN COMMITTEE FOR STANDARDIZATION
COMITÉ EUROPÉEN DE NORMALISATION
EUROPÄISCHES KOMITEE FÜR NORMUNG

CEN-CENELEC Management Centre: Avenue Marnix 17, B-1000 Brussels

Contents

	Page
European foreword	3
1 Scope.....	4
2 Normative references.....	4
3 Required characteristics	5
3.1 Configuration - Dimensions - Masses	5
3.2 Tolerances of form and position	5
3.3 Materials	5
3.4 Surface treatments	5
4 Designation	7
5 Marking.....	7
6 Technical specification	7

European foreword

This document (EN 2879:2017) has been prepared by the Aerospace and Defence Industries Association of Europe - Standardization (ASD-STAN).

After enquiries and votes carried out in accordance with the rules of this Association, this European Standard has received the approval of the National Associations and the Official Services of the member countries of ASD, prior to its presentation to CEN.

This European Standard shall be given the status of a national standard, either by publication of an identical text or by endorsement, at the latest by July 2017, and conflicting national standards shall be withdrawn at the latest by July 2017.

Attention is drawn to the possibility that some of the elements of this document may be the subject of patent rights. CEN [and/or CENELEC] shall not be held responsible for identifying any or all such patent rights.

According to the CEN-CENELEC Internal Regulations, the national standards organizations of the following countries are bound to implement this European Standard: Austria, Belgium, Bulgaria, Croatia, Cyprus, Czech Republic, Denmark, Estonia, Finland, Former Yugoslav Republic of Macedonia, France, Germany, Greece, Hungary, Iceland, Ireland, Italy, Latvia, Lithuania, Luxembourg, Malta, Netherlands, Norway, Poland, Portugal, Romania, Serbia, Slovakia, Slovenia, Spain, Sweden, Switzerland, Turkey and the United Kingdom.

1 Scope

This European Standard specifies the characteristics of self-locking, air resistant, sealing, floating, two lug anchor nuts, with counterbore, in corrosion resisting steel, passivated, MoS₂ lubricated.

Classification: 900 MPa ¹⁾ / 235 °C ²⁾.

2 Normative references

The following documents, in whole or in part, are normatively referenced in this document and are indispensable for its application. For dated references, only the edition cited applies. For undated references, the latest edition of the referenced document (including any amendments) applies.

EN 2424, *Aerospace series — Marking of aerospace products*

EN 2491, *Aerospace series — Molybdenum disulphide dry lubricants — Coating methods*

EN 2516, *Aerospace series — Passivation of corrosion resisting steels and decontamination of nickel base alloys*

EN 9100, *Quality Management Systems - Requirements for Aviation, Space and Defense Organizations*

EN 9133, *Aerospace series - Quality management systems - Qualification procedure for aerospace standard parts*

ISO 5855-2, *Aerospace — MJ threads — Part 2: Limit dimensions for bolts and nuts*

ISO 5858, *Aerospace — Nuts, self-locking, with maximum operating temperature less than or equal to 425 degrees C — Procurement specification*

ISO 8788, *Aerospace — Nuts, metric — Tolerances of form and position*

ISO 8940, *Aerospace — Nuts, anchor, self-locking, sealing, floating, two-lug, with counterbore, with MJ threads, classifications: 900 MPa (at ambient temperature)/120 degrees C, 900 MPa (at ambient temperature)/175 degrees C and 900 MPa (at ambient temperature)/235 degrees C — Dimensions*

SAE AMS 3304G, *Silicone Rubber, General Purpose, 70 Durometer* ³⁾

TR 3791, *Aerospace series — Materials for self-locking nuts, threaded inserts and screw thread inserts of temperature classes ≤ 425 °C* ⁴⁾

1) Corresponds to the minimum tensile stress which the nut is able to withstand at ambient temperature without breaking or cracking when tested with a bolt of a higher strength class.

2) Maximum temperature that the nut is able to withstand, without permanent alteration to its original characteristics, after ambient temperature has been restored. The maximum temperature is conditioned by the seal material.

3) Published by: SAE National (US) Society of Automotive Engineers <http://www.sae.org/>

4) Published as ASD-STAN Technical Report at the date of publication of this European Standard by AeroSpace and Defence industries Association of Europe - Standardization (ASD-STAN) (www.asd-stan.org)

3 Required characteristics

3.1 Configuration – Dimensions – Masses

See Figure 1 and Table 1.

Dimensions and tolerances are: in conformity with ISO 8940, expressed in millimetres and apply after surface treatment but before MoS₂ lubrication.

Details of form not stated are at the manufacturer's option.

3.2 Tolerances of form and position

ISO 8788

3.3 Materials

Cage, seal retainer and nut element: TR 3791.

Sealing ring: rubber, air resistant per SAE AMS 3304 or equivalent.

3.4 Surface treatments

Cage and seal retainer: EN 2516

Nut element: EN 2491, thickness not specified, mandatory on threads, optional on other surfaces

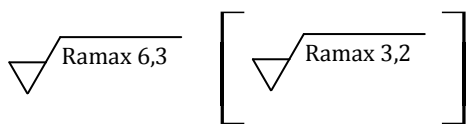

These values in micrometres apply before surface treatment. They do not apply to threads, punched holes or sheared edges the surface texture of which will be as achieved by usual manufacturing methods.

Remove sharp edges 0,1 to 0,4.

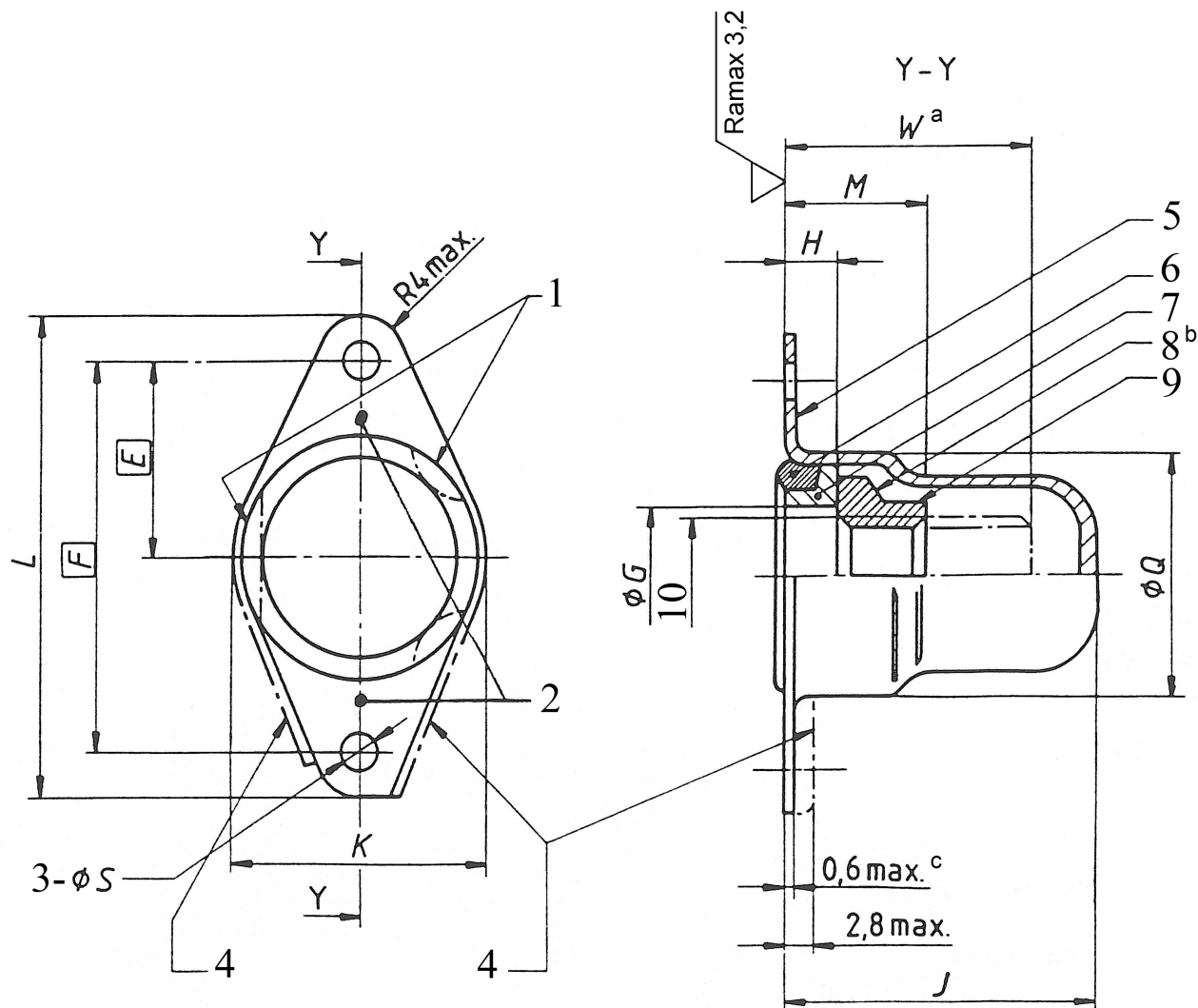

Key

- 1 Threaded element anti-rotational device (form at manufacturer's discretion)
- 2 Marking
- 3 2 holes
- 4 Choice of flange at manufacturer's discretion
- 5 Cage
- 6 Seal
- 7 Seal retainer
- 8 Nut element ^b
- 9 Form out-of-round in this area to achieve the self-locking requirement (tooling marks permissible)

- a Maximum bolt thread intrusion
- b Minimum radial float of nut element: 0,5
- c Lug thickness at the rivet location

Figure 1

Table 1

Diameter code	Thread ^a	E	F	G	H	J	K	L	M	Q	S	W	Mass ^b
				min.	min.	max.	max.	max.	max.	max.	+0,2 0	max.	
050	MJ5×0,8-4H6H	9,5	19	6	3,4	16,2	14,4	24,6	7,9	12,5	2,5	14,4	4,3
060	MJ6×1-4H5H	11	22	7	4,1	19,2	17	29	9,5	16		17,4	7
080	MJ8×1-4H5H	13	26	9		20,3	19,4	32,5	11,3	18,5		3	18,5

^a In accordance with ISO 5855-2. In the self-locking zone the tolerances apply before forming out-of-round.
^b Approximate values (kg/1 000 pieces), given for information purposes only.

4 Designation

EXAMPLE

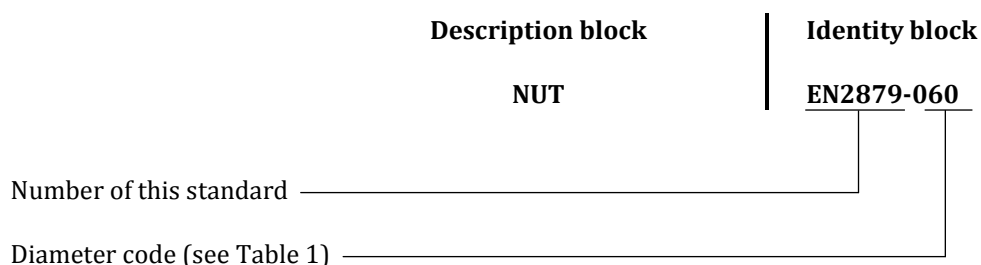

NOTE If necessary, the code I9005 shall be placed between the description block and the identity block.

5 Marking

EN 2424, style N. See Figure 1.

6 Technical specification

ISO 5858, except for:

- Approval of manufacturers: see EN 9100;
- Qualification of products: see EN 9133.

British Standards Institution (BSI)

BSI is the national body responsible for preparing British Standards and other standards-related publications, information and services.

BSI is incorporated by Royal Charter. British Standards and other standardization products are published by BSI Standards Limited.

About us

We bring together business, industry, government, consumers, innovators and others to shape their combined experience and expertise into standards-based solutions.

The knowledge embodied in our standards has been carefully assembled in a dependable format and refined through our open consultation process. Organizations of all sizes and across all sectors choose standards to help them achieve their goals.

Information on standards

We can provide you with the knowledge that your organization needs to succeed. Find out more about British Standards by visiting our website at bsigroup.com/standards or contacting our Customer Services team or Knowledge Centre.

Buying standards

You can buy and download PDF versions of BSI publications, including British and adopted European and international standards, through our website at bsigroup.com/shop, where hard copies can also be purchased.

If you need international and foreign standards from other Standards Development Organizations, hard copies can be ordered from our Customer Services team.

Copyright in BSI publications

All the content in BSI publications, including British Standards, is the property of and copyrighted by BSI or some person or entity that owns copyright in the information used (such as the international standardization bodies) and has formally licensed such information to BSI for commercial publication and use.

Save for the provisions below, you may not transfer, share or disseminate any portion of the standard to any other person. You may not adapt, distribute, commercially exploit, or publicly display the standard or any portion thereof in any manner whatsoever without BSI's prior written consent.

Storing and using standards

Standards purchased in soft copy format:

- A British Standard purchased in soft copy format is licensed to a sole named user for personal or internal company use only.
- The standard may be stored on more than 1 device provided that it is accessible by the sole named user only and that only 1 copy is accessed at any one time.
- A single paper copy may be printed for personal or internal company use only.

Standards purchased in hard copy format:

- A British Standard purchased in hard copy format is for personal or internal company use only.
- It may not be further reproduced – in any format – to create an additional copy. This includes scanning of the document.

If you need more than 1 copy of the document, or if you wish to share the document on an internal network, you can save money by choosing a subscription product (see 'Subscriptions').

Reproducing extracts

For permission to reproduce content from BSI publications contact the BSI Copyright & Licensing team.

Subscriptions

Our range of subscription services are designed to make using standards easier for you. For further information on our subscription products go to bsigroup.com/subscriptions.

With **British Standards Online (BSOL)** you'll have instant access to over 55,000 British and adopted European and international standards from your desktop. It's available 24/7 and is refreshed daily so you'll always be up to date.

You can keep in touch with standards developments and receive substantial discounts on the purchase price of standards, both in single copy and subscription format, by becoming a **BSI Subscribing Member**.

PLUS is an updating service exclusive to BSI Subscribing Members. You will automatically receive the latest hard copy of your standards when they're revised or replaced.

To find out more about becoming a BSI Subscribing Member and the benefits of membership, please visit bsigroup.com/shop.

With a **Multi-User Network Licence (MUNL)** you are able to host standards publications on your intranet. Licences can cover as few or as many users as you wish. With updates supplied as soon as they're available, you can be sure your documentation is current. For further information, email subscriptions@bsigroup.com.

Revisions

Our British Standards and other publications are updated by amendment or revision.

We continually improve the quality of our products and services to benefit your business. If you find an inaccuracy or ambiguity within a British Standard or other BSI publication please inform the Knowledge Centre.

Useful Contacts

Customer Services

Tel: +44 345 086 9001

Email (orders): orders@bsigroup.com

Email (enquiries): cservices@bsigroup.com

Subscriptions

Tel: +44 345 086 9001

Email: subscriptions@bsigroup.com

Knowledge Centre

Tel: +44 20 8996 7004

Email: knowledgecentre@bsigroup.com

Copyright & Licensing

Tel: +44 20 8996 7070

Email: copyright@bsigroup.com

BSI Group Headquarters

389 Chiswick High Road London W4 4AL UK