



BSI Standards Publication

**Aerospace series — Burning  
behaviour of non-metallic  
materials under the influence  
of radiating heat and flames  
— Determination of smoke  
density and gas components  
in the smoke of materials —  
Test equipment apparatus and  
media**

**National foreword**

This British Standard is the UK implementation of EN 2824:2011.

The UK participation in its preparation was entrusted to Technical Committee ACE/65, Non-metallic materials for aerospace purposes (excluding textiles).

A list of organizations represented on this committee can be obtained on request to its secretary.

This publication does not purport to include all the necessary provisions of a contract. Users are responsible for its correct application.

© BSI 2011

ISBN 978 0 580 73666 7

ICS 13.220.40; 49.025.99

**Compliance with a British Standard cannot confer immunity from legal obligations.**

This British Standard was published under the authority of the Standards Policy and Strategy Committee on 30 November 2011.

**Amendments issued since publication**

Date	Text affected
------	---------------

---

EUROPEAN STANDARD

**EN 2824**

NORME EUROPÉENNE

EUROPÄISCHE NORM

November 2011

ICS 13.220.40; 49.025.99

English Version

**Aerospace series - Burning behaviour of non-metallic materials  
under the influence of radiating heat and flames - Determination  
of smoke density and gas components in the smoke of materials  
- Test equipment apparatus and media**

Série aérospatiale - Comportement au feu des matériaux  
non-métalliques sous l'action de chaleur rayonnante et de  
flammes - Détermination de la densité de fumée et des  
composants des gaz de fumée des matériaux -  
Équipement, appareils et moyens d'essai

Luft- und Raumfahrt - Brandverhalten nichtmetallischer  
Werkstoffe unter Einwirkung von strahlender Wärme und  
Flammen - Bestimmung der Rauchdichte und der  
Rauchgaskomponenten von Werkstoffen - Prüfeinrichtung  
Prüfgeräte und Prüfmittel

This European Standard was approved by CEN on 12 February 2011.

CEN members are bound to comply with the CEN/CENELEC Internal Regulations which stipulate the conditions for giving this European Standard the status of a national standard without any alteration. Up-to-date lists and bibliographical references concerning such national standards may be obtained on application to the CEN-CENELEC Management Centre or to any CEN member.

This European Standard exists in three official versions (English, French, German). A version in any other language made by translation under the responsibility of a CEN member into its own language and notified to the CEN-CENELEC Management Centre has the same status as the official versions.

CEN members are the national standards bodies of Austria, Belgium, Bulgaria, Croatia, Cyprus, Czech Republic, Denmark, Estonia, Finland, France, Germany, Greece, Hungary, Iceland, Ireland, Italy, Latvia, Lithuania, Luxembourg, Malta, Netherlands, Norway, Poland, Portugal, Romania, Slovakia, Slovenia, Spain, Sweden, Switzerland and United Kingdom.



EUROPEAN COMMITTEE FOR STANDARDIZATION  
COMITÉ EUROPÉEN DE NORMALISATION  
EUROPÄISCHES KOMITEE FÜR NORMUNG

**Management Centre: Avenue Marnix 17, B-1000 Brussels**

## Contents

Page

Foreword.....	3
1 Scope .....	4
2 Normative references .....	4
3 Apparatus .....	4
3.1 General.....	4
3.2 Test chamber.....	5
3.3 Radiant heat furnace .....	5
3.4 Specimen holder .....	5
3.5 Photometric system .....	5
3.6 Radiometer .....	6
3.7 Thermocouple .....	6
3.8 Manometer for chamber pressure measurements .....	6
3.9 Burner .....	6
3.10 Gas sampling probes .....	6
3.11 Plastic bags for gas sampling .....	7
3.12 Vacuum chamber .....	7
3.13 Vacuum pump .....	7
3.14 Alternative gas sampling methods .....	7
3.15 Colorimetric tubes .....	7
3.16 Dosing pump .....	7
3.17 Ancillary equipment for wet analysis .....	7
4 Cleaning of the test chamber .....	8
5 Specimens .....	8
5.1 Number of specimens .....	8
5.2 Conditioning.....	8
5.3 Dimensions and shape of specimens .....	8
5.4 Specimen mounting.....	8

## Foreword

This document (EN 2824:2011) has been prepared by the Aerospace and Defence Industries Association of Europe - Standardization (ASD-STAN).

After enquiries and votes carried out in accordance with the rules of this Association, this Standard has received the approval of the National Associations and the Official Services of the member countries of ASD, prior to its presentation to CEN.

This European Standard shall be given the status of a national standard, either by publication of an identical text or by endorsement, at the latest by May 2012, and conflicting national standards shall be withdrawn at the latest by May 2012.

Attention is drawn to the possibility that some of the elements of this document may be the subject of patent rights. CEN [and/or CENELEC] shall not be held responsible for identifying any or all such patent rights.

According to the CEN/CENELEC Internal Regulations, the national standards organizations of the following countries are bound to implement this European Standard: Austria, Belgium, Bulgaria, Croatia, Cyprus, Czech Republic, Denmark, Estonia, Finland, France, Germany, Greece, Hungary, Iceland, Ireland, Italy, Latvia, Lithuania, Luxembourg, Malta, Netherlands, Norway, Poland, Portugal, Romania, Slovakia, Slovenia, Spain, Sweden, Switzerland and the United Kingdom.

## 1 Scope

This European Standard defines the test equipment, apparatus and media required for determination of the smoke density according to EN 2825 and the concentration of the gas components in the smoke according to EN 2826 due to pyrolytic decomposition of solid materials and composite materials of up to 25 mm in thickness under the influence of radiant heat only or with simultaneous flame application.

This test method applies exclusively to materials whose specific standard requires this type of test. It cannot be substituted for the statutory tests required for a final specific use of the material concerned.

NOTE The smoke gas density and the gas components in the smoke are determined according to the specific environmental and test conditions defined in this standard, in EN 2825 and EN 2826. No studies have been made up to now to determine whether the results can be transferred to differing conditions, particularly to actual fire conditions. The inhalatory toxicological risk and irritancy affect cannot be assessed by merely measuring the concentration of individual gas components in the smoke.

## 2 Normative references

The following referenced documents are indispensable for the application of this document. For dated references, only the edition cited applies. For undated references, the latest edition of the referenced document (including any amendments) applies.

EN 2743, *Aerospace series — Fibre reinforced plastics — Standard procedures for conditioning prior to testing unaged materials*

EN 2825, *Aerospace series — Burning behaviour of non metallic materials under the influence of radiating heat and flames — Determination of smoke density*

EN 2826, *Aerospace series — Burning behaviour of non metallic materials under the influence of radiating heat and flames — Determination of gas components in the smoke*

ISO 2768-1, *General tolerances — Part 1: Tolerances for linear and angular dimensions without individual tolerance indications*

ISO 2768-2, *General tolerances — Part 2: Geometrical tolerances for features without individual tolerance indications*

## 3 Apparatus

### 3.1 General

The test equipment comprises the test chamber described in 3.2, incorporating the devices specified in 3.3 to 3.9, as well as the ancillary equipment as detailed in 3.10 to 3.17.

### 3.2 Test chamber

See Figure 1.

The test chamber shall be designed to provide inside dimensions of  $(914 \times 610 \times 914)$  mm  $\pm$  3 mm for width, depth, and height respectively. The interior surfaces shall consist of porcelain-enamelled metal or equivalent coated metal resistant to chemical attack and corrosion, and suitable for cleaning. Panels of 10 mm thickness of porcelain-enamelled steel (interior surface) laminated to a heat-resistant core and backed with corrosion-resistant steel (exterior surface) have been found suitable. Sealed windows shall be provided to accommodate a vertical photometric system. All other chamber penetrations shall also be sealed. When all openings are closed, the chamber shall be capable of developing and maintaining positive pressure during the test period. In order to avoid an excessive increase of pressure in the chamber during testing an airtight safety disc is required, e. g. a sheet of aluminium foil of thickness not greater than 0,04 mm and a minimum area of 800 cm<sup>2</sup> shall be provided in an opening of the chamber floor.

### 3.3 Radiant heat furnace

See Figure 2.

The furnace shall be located according to Figure 3 equidistant from the front and back of the test chamber. The furnace control system shall maintain the required irradiance level of  $(25,0 \pm 0,5)$  kW/m<sup>2</sup> on the specimen surface for 20 min under steady-state conditions with the chamber door closed (to be demonstrated in calibration). The control system shall consist of a variable transformer or an equivalent control device, and a voltmeter or other means for monitoring the electrical input. Where line voltage fluctuations exceed  $\pm 2,5$  %, a constant-voltage transformer is required to maintain the prescribed irradiance level.

### 3.4 Specimen holder

Stops have to be provided to center the specimen accurately in front of the furnace.

Figure 4 shows the construction of the holder. Two wires have to be placed in front of the specimen.

### 3.5 Photometric system

**3.5.1** The photometric system shall conform to Figure 5. The light path shall be oriented vertically to reduce influences resulting from stratification of the smoke generated by materials under test. The system shall conform to 3.5.2 to 3.5.4.

**3.5.2** The light source shall be a 6 V incandescent lamp, operated at a fixed voltage to provide a brightness temperature of  $(2\ 200 \pm 100)$  K. The light source shall be located in a sealed and light-tight box. This box shall contain the necessary optics to provide a collimated light beam of about 50 mm diameter passing vertically through the chamber.

**3.5.3** A photomultiplier with a spectral sensitivity rating of S-4 and a dark current of less than  $10^{-9}$  A shall be used. For amplification, a multirange amplifier shall be used, suitable to measure continuously the relative light intensity in percentage transmission over at least five orders of magnitude. The system shall have a linear response with respect to transmittance and an accuracy of  $\pm 3$  % of the maximum reading on any range. A set of nine gelatin compensating filters varying from 0,1 to 0,9 neutral density is mounted in a number of one or more as required in the optical measuring system to provide for correction of light source or photomultiplier aging and reduction in light transmission through discoloured or abraded optical windows. A light-tight box located directly opposite the light source shall be provided to mount the photodetector housing and the associated optics. A glass window shall be used to isolate the photodetector and its optics from the chamber atmosphere.

**3.5.4** In addition to the compensating filter as per 3.5.3, a neutral density filter ND-2 (grey filter) for extending the measuring range up to the optical density 6 is incorporated in the smoke density chamber. Where values of smoke density  $D_s > 500$  are measured, it may be necessary to provide a chamber window cover to prevent room light from being scattered into the photomultiplier and thus an incorrect higher transmission value.

### 3.6 Radiometer

The radiometer according to Figure 6 for standardizing the output of the radiant heat furnace shall be of the circular foil type <sup>1)</sup>. It shall have a stainless steel reflective heat shield with an aperture of about 38 mm on the front and a finned cooler mounted on the rear, to which compressed air is supplied in order to maintain a constant radiometer body temperature of  $(93 \pm 3) ^\circ\text{C}$ . The radiometer shall be connected directly to a recorder suitable for recording an irradiance signal of  $25,0 \text{ kW/m}^2$  to an accuracy of  $0,5 \text{ kW/m}^2$ .

### 3.7 Thermocouple

A thermocouple shall be fixed to the centre of the inner surface of the chamber wall opposite the door.

### 3.8 Manometer for chamber pressure measurements

A U-tube manometer with a range up to 1 490 Pa water column shall be provided according to Figure 7 in order to monitor chamber pressure and leakage. The pressure measurement point shall be mounted through a 25 mm diameter vent in the chamber.

### 3.9 Burner

A six-tube burner as shown in Figure 8 shall be used for the flaming exposure test. The burner shall be centered in front of and parallel to the specimen holder. The orifices of the two horizontal tubes shall be centered at  $(6,4 \pm 1,5)$  mm above the lower opening of the specimen holder and at a distance of  $(6,4 \pm 1,5)$  mm from the face of the specimen surface. Provision shall be made to move the burner out of the above-described position during non-flaming exposures. The fuel used shall be propane with a purity of not less than 95 %. Filtered oil-free air and propane shall be fed through calibrated flowmeters and needle valves at  $(500 \pm 20) \text{ cm}^3/\text{min}$  for air and  $(50 \pm 3) \text{ cm}^3/\text{min}$  for propane and premixed prior to the entry into the burner (related to  $23 ^\circ\text{C}$  and  $0,1 \text{ MPa}$ ).

NOTE The flowmeters shall be calibrated at regular frequency. The burner is properly adjusted if the blue flame cone of the horizontal flames is approximately 6 mm long.

### 3.10 Gas sampling probes

The gas sampling is carried out by means of three probes of about 5 mm inside diameter (see Figure 9) reaching into the geometrical center of the chamber. The distance between the three probes shall not exceed 12 mm. These probes shall be connected to the gas sampling supply lines by means of tube connectors provided at the top side of the test chamber. Lines not in use have to be shut.

For direct measurement in the chamber, a rubber sleeve shall be provided to hold colorimetric test tubes on one of the polypropylene probes inside the chamber.

---

1) The operation is described by: Gardon R, "An instrument for the measurement of Intense Thermal Radiation", Review of Scientific Instruments, Vol. 24, 1953, pp. 366-370.



### 3.11 Plastic bags for gas sampling

The sampling bags shall consist of a plastic film having a high chemical and mechanical resistance. The minimum volume shall be 10 dm<sup>3</sup>.

The gas sampling bags have to be constructed for minimal gas diffusion and water vapour transmissibility so that the gas composition changes by diffusion are negligible.

### 3.12 Vacuum chamber

Gas sampling shall be made in such a manner that the composition of the combustion gases will not be changed. A change in the gas composition may occur for instance when using unsuitable installation causing a loss of gas due to leakages or a condensation of the gases.

A vacuum chamber, for example, is suitable for sampling. The filling of the bag is effected by the differential pressure between the vacuum chamber and the test chamber. After termination of the gas analysis, the bag is evacuated.

A typical sampling arrangement is shown in Figure 9.

The vacuum chamber is provided with two shut-off valves 1 and 2 and a transparent acrylic cover. The chamber is connected to the vacuum pump through a shut-off valve 1. The venting of the chamber is performed after filling of the sampling bags through a second shut-off valve 2. Evacuation pressure can be controlled by means of a vacuummeter.

The transparent cover is provided with a fixable coupling 5 for connection of the sampling bag. This is connected to the test chamber by a polypropylene tube with shut-off valve 3. The venting of the tube prior to gas sampling is effected through a bypass provided on the tube close to the transparent cover, through a shut-off valve 3 and a coupling 8.

### 3.13 Vacuum pump

A vacuum pump shall be used which permits evacuation of the vacuum chamber according to 3.12 to 100 kPa within 60 s.

### 3.14 Alternative gas sampling methods

Alternatively to the method of filling the gas sampling bags described in 3.12, other methods, e. g. filling of gas sampling bags by a suitable pump, might be appropriate.

### 3.15 Colorimetric tubes

The concentration of individual gas components in the smoke is normally determined using colorimetric tubes.

### 3.16 Dosing pump

Dosing pumps shall be used for measuring the gases with colorimetric tubes with a feed rate of  $(100 \pm 3)$  cm<sup>3</sup> of gas per stroke.

### 3.17 Ancillary equipment for wet analysis

If gas components cannot be satisfactorily determined by means of colorimetric tubes, a wet analysis shall be performed. The following ancillary equipment is required: one or two 100 ml scrubbers according to Figure 10, a membrane pump, a gas meter and the component-specific indicator and reference electrodes as well as a suitable device for measuring the pH values.

## 4 Cleaning of the test chamber

The test chamber shall be periodically checked for contamination by visual inspection. Ammoniacal spray detergents and soft scouring pads shall be used for cleaning. Prior to each test, the exposed surfaces of the glass windows separating the photodetector and the light source housing from the interior of the chamber shall be cleaned with a suitable solvent (e. g. ethyl alcohol).

Charred residues on the specimen holder and horizontal rods shall be removed between the tests. The cleanliness of the system shall be verified by a blank test for residual HF or HCl in the chamber air.

## 5 Specimens

### 5.1 Number of specimens

Unless otherwise specified, a minimum of four specimens shall be tested each under flaming and non-flaming exposure. In the event of high scatter of the test results, the number of specimens shall be increased.

### 5.2 Conditioning

Unless otherwise specified the specimens shall be conditioned for a minimum of 24 h in the standard atmosphere of  $(23 \pm 2)$  °C and  $(50 \pm 5)$  % relative humidity according to EN 2743; they shall only be removed from the conditioning chamber immediately before testing.

### 5.3 Dimensions and shape of specimens

Unless otherwise specified, materials up to 25 mm thickness shall be  $(76 \times 76)$  mm by installed thickness. For inhomogenous materials the surface exposed at installation shall be tested. Materials and composites supplied with a thickness greater than 25 mm shall be reduced from the non-exposed side to a thickness of 25 mm.

Flat sections of the same thickness and composition can be tested in place of curved, moulded or special parts.

### 5.4 Specimen mounting

The specimens shall be covered on the rear side, along the edges and over the front surface periphery with aluminium foil of 0,04 mm thickness. Care shall be taken not to puncture or unnecessarily wrinkle the foil. The specimens shall be introduced into the holder, backed with a calcium silicate sheet of  $(76 \times 76 \times 9)$  mm, apparent density about  $800 \text{ kg/m}^3$ , or with some other fire-proof material of approx. identical thermal conductivity, and secured with the spring and retaining rod. Care shall be taken not to deform flexible materials below their normal thickness. Excess foil along the front edges shall be removed after mounting.

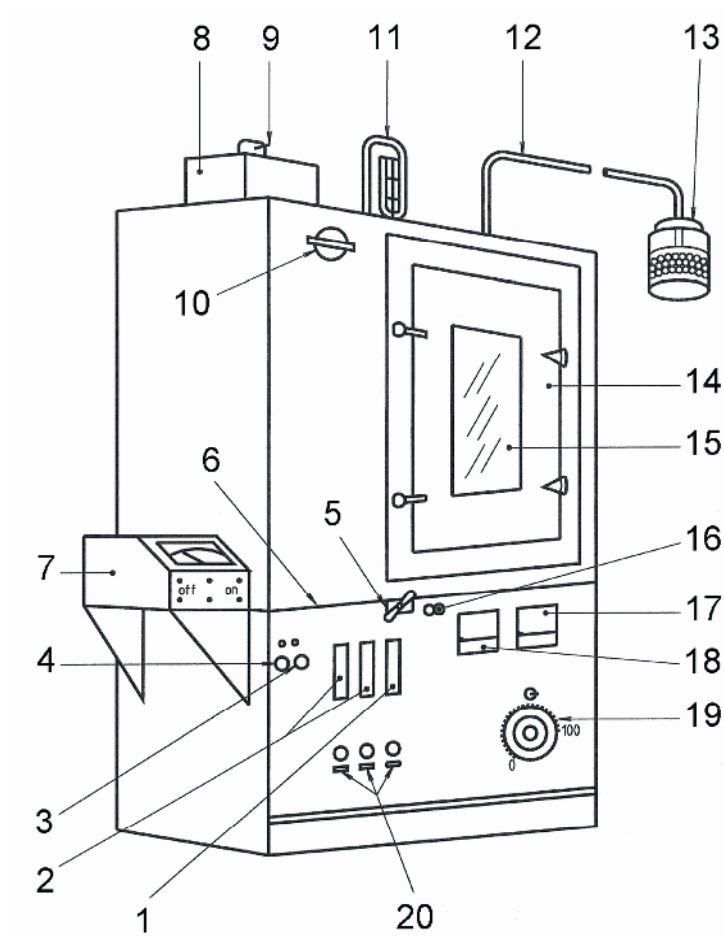

**Key**

- |    |  |    |  |
|----|--|----|--|
| 1  | Flowmeter for radiometer cooling air                                 | 11 | U-tube manometer (range up to 152 mm of water)       |
| 2  | Flowmeter for air and gas (burner)                                   | 12 | Flexible tubing                                      |
| 3  | Light source switch  | 13 | Simple pressure regulator open, water-filled bottle) |
| 4  | Line switch  | 14 | Door   |
| 5  | Exhaust vent   | 15 | Window   |
| 6  | Floor of chamber   | 16 | Radiometer output jacks                              |
| 7  | Photometer, power supply and measuring amplifier for photomultiplier | 17 | Temperature (wall) indicator                         |
| 8  | Photomultiplier housing  | 18 | Voltmeter (radiant heat furnace)                     |
| 9  | Shutter  | 19 | Variable transformer (furnace)                       |
| 10 | Inlet vent   | 20 | Air and gas valves                                   |

**Figure 1 — Smoke density test chamber – General arrangement**

Dimensions in millimetres

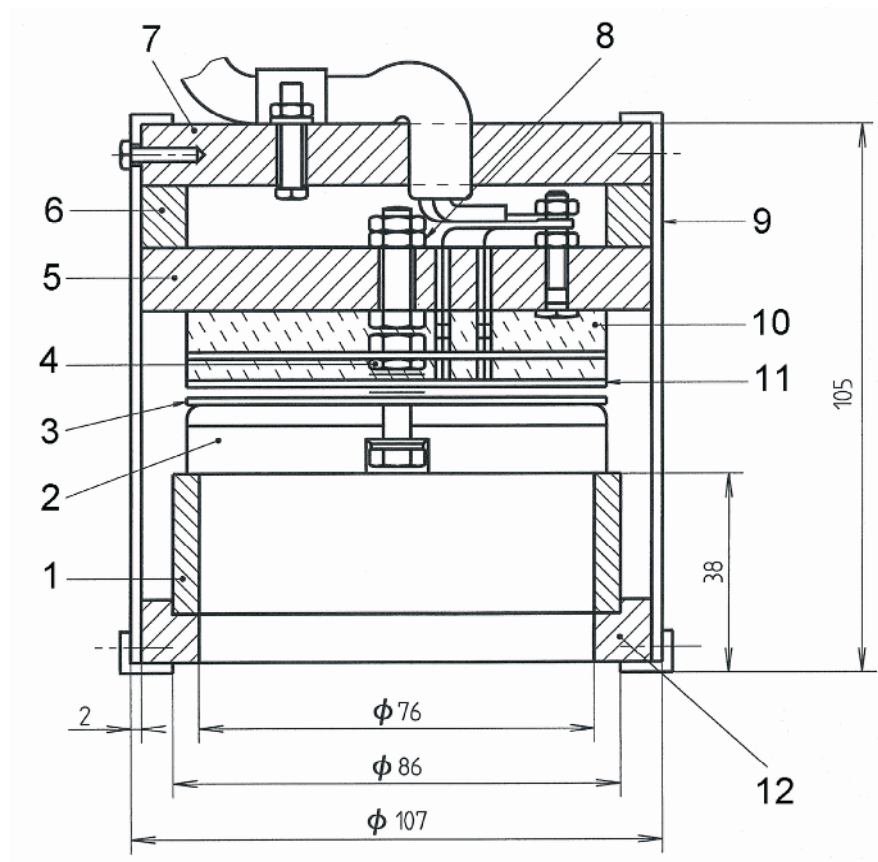

**Key**

- |                            |                                  |
|----------------------------|----------------------------------|
| 1 Ceramic tube             | 7 Rear insulating disk           |
| 2 Heater plate (525 W)     | 8 Stainless steel mounting screw |
| 3 Insulating gasket        | 9 Stainless steel tube           |
| 4 Stainless steel lock nut | 10 Glasswool packing             |
| 5 Center insulating disk   | 11 Stainless steels reflectors   |
| 6 Insulating spacer ring   | 12 Front insulating ring         |

NOTE Coarse tolerances see ISO 2768-1 and ISO 2768-2.

**Figure 2 — Typical furnace details**

Dimensions in millimetres

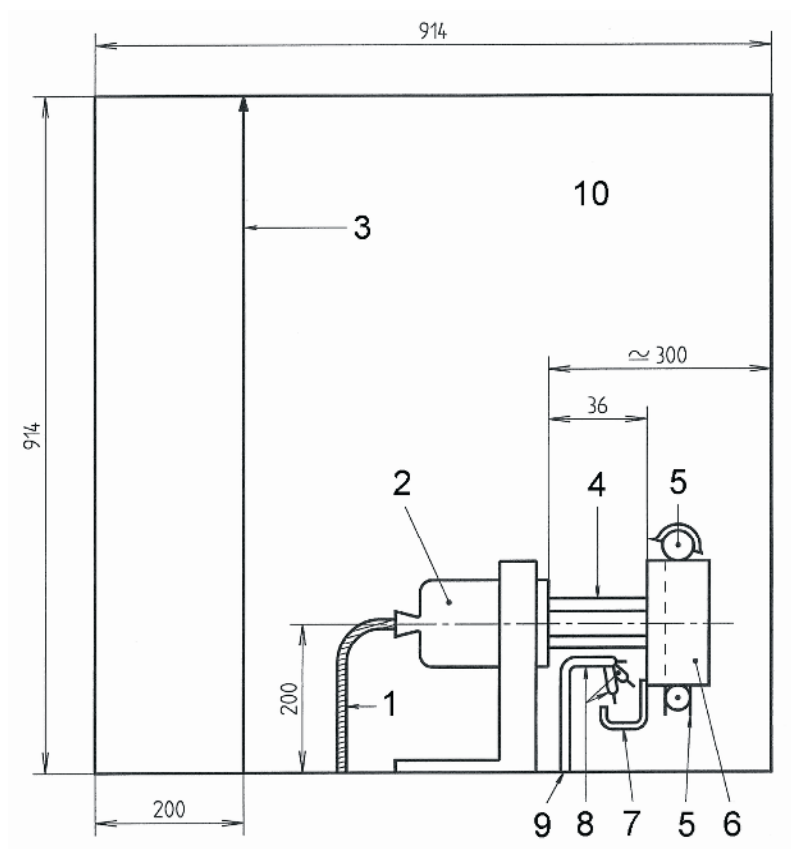

**Key**

- |  |  |
|--|--|
| 1 Electrical connector                     | 6 Specimen holder  |
| 2 Electric furnace (radiant energy source) | 7 Trough to trap drips, see note 1   |
| 3 Vertical light beam (915 mm path)        | 8 Six-tube burner (6 flamelets, 3-directional), ignites flammable gases expelled by specimen, see note 2 |
| 4 Radiant energy heating specimen face     | 9 Gas-air supply to burner   |
| 5 Rod supports                             | 10 Chamber size 0,51 m <sup>3</sup>  |

NOTE 1 Replaced by radiometer when calibrating the chamber.

NOTE 2 Burner is removed during calibration and during non-flaming exposure test.

NOTE 3 Coarse tolerances see ISO 2768-1 and ISO 2768-2.

**Figure 3 — Test set-up – Smoke density test chamber**

Dimensions in millimetres

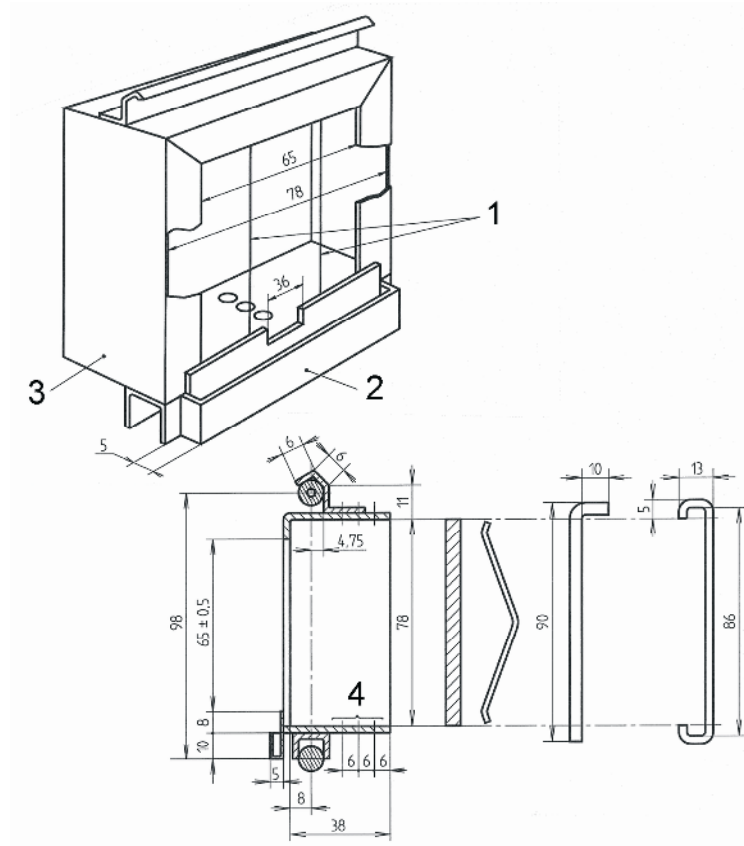

**Key**

- 1 Steel wires ( $\varnothing 0,5$  mm)
- 2 Trough
- 3 0,3 mm stainless steel plate
- 4  $\varnothing 3$  holes

NOTE Coarse tolerances see ISO 2768-1 and ISO 2768-2.

**Figure 4 — Specimen holder**

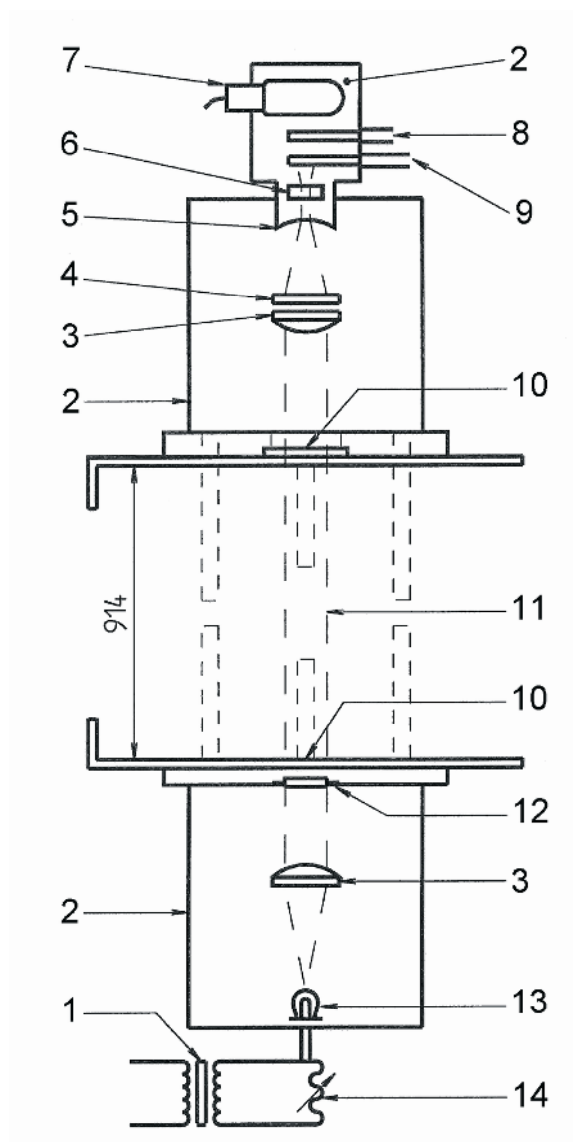

**Key**

- |                                   |                                 |
|-----------------------------------|---------------------------------|
| 1 Transformer                     | 8 Range-extension filter (ND-2) |
| 2 Housing                         | 9 Shutter                       |
| 3 Lens (focal length 140 mm)      | 10 Window                       |
| 4 Compensating filter             | 11 Parallel light beam          |
| 5 Aperture disk                   | 12 Window heater                |
| 6 Diffuser filter                 | 13 Light source                 |
| 7 Photomultiplier tube and socket | 14 Adjustable resistor          |

**Figure 5 — Photometric system**

Dimensions in millimetres

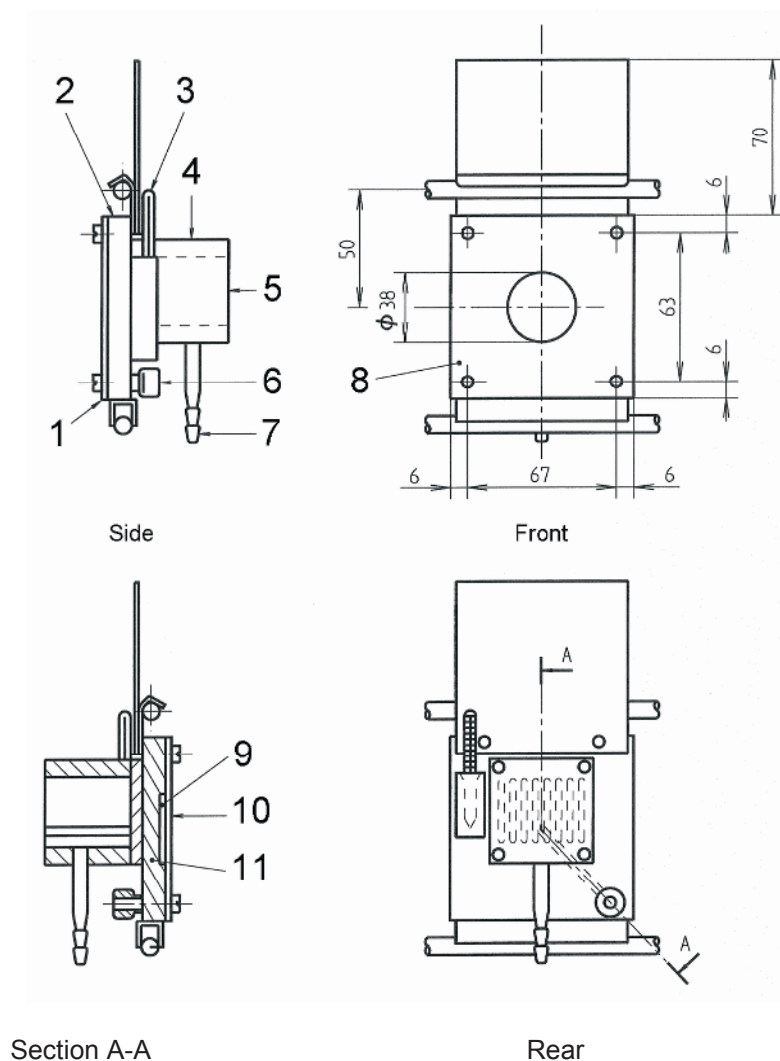

**Key**

- |                              |  |
|------------------------------|--|
| 1 Aluminium foil             | 7 Air hose adapter   |
| 2 12,5 mm thick copper flat  | 8 0,9 mm stainless steel convection shield   |
| 3 Thermometer in well        | 9 Recess of 38 mm diameter, 3 mm deep  |
| 4 Brazed cover               | 10 Metallic foil, 0,25 mm thick sweat soldered to copper flat, painted black using special lacquer |
| 5 Finned cooler              | 11 Copper wire, silver brazed (remove all flux after brazing)                                      |
| 6 Microphone cable connector |  |

NOTE Coarse tolerances see ISO 2768-1 and ISO 2768-2.

**Figure 6 — Radiometer details**



Dimensions in millimetres

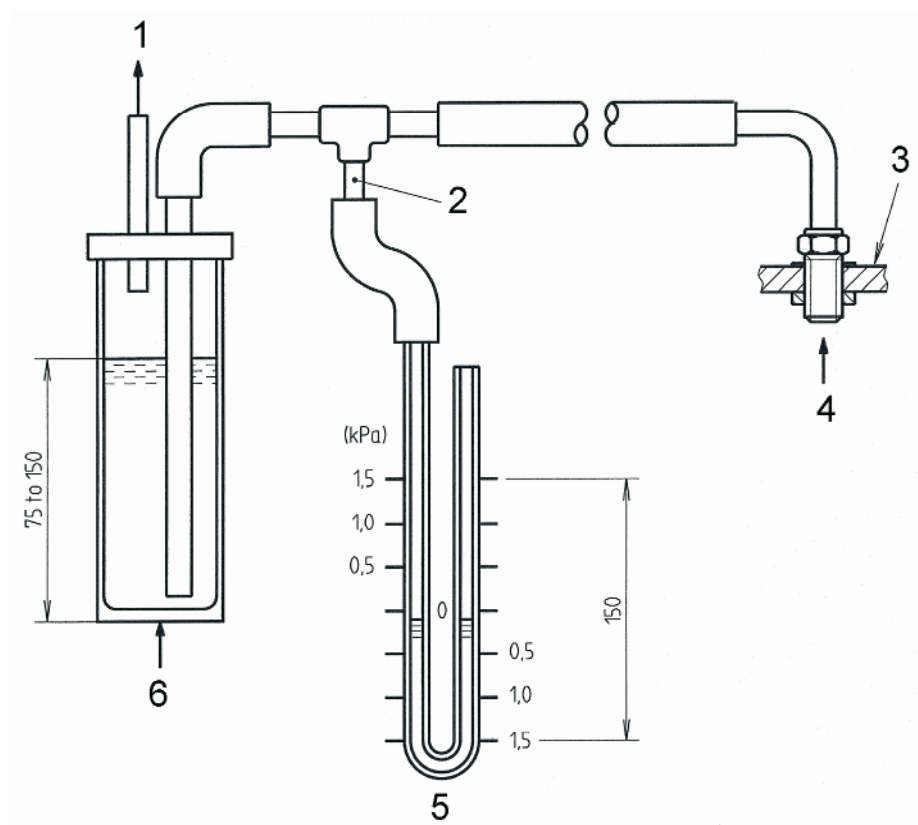

**Key**

- 1 To exhaust system
- 2 Restriction to prevent liquid blow-out
- 3 Chamber wall
- 4 Effluent from chamber
- 5 Manometer filled to zero mark with water-dye solution
- 6 Glas jar with cover

**Figure 7 — Manometer and chamber pressure relief**

Dimensions in millimetres

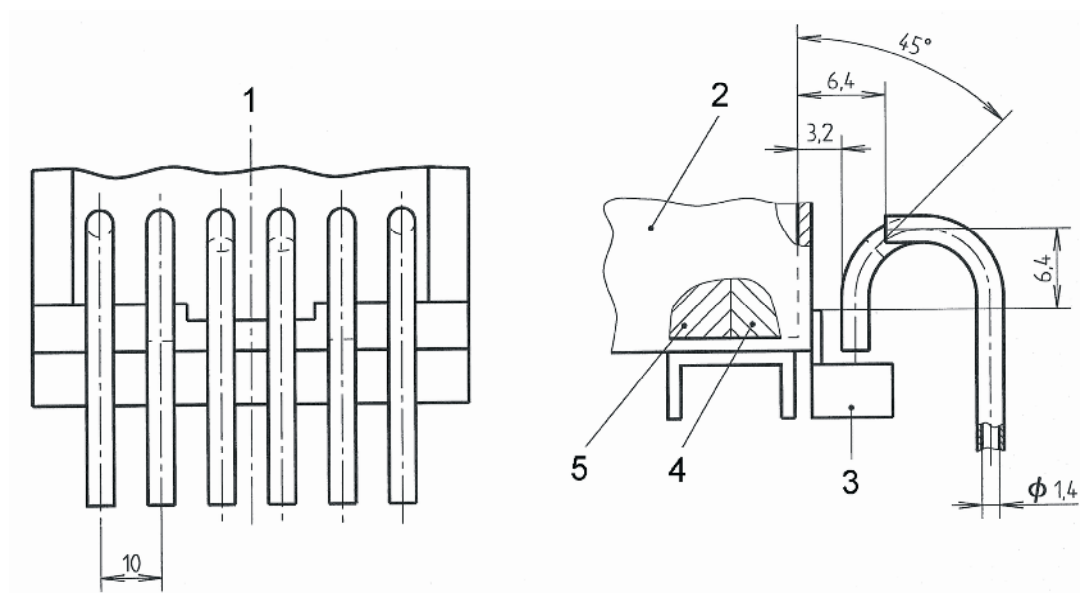

**Key**

- 1 Six-flamelets burner (three-directional)
- 2 Specimen holder
- 3 Trough
- 4 Specimen
- 5 Plate made from heat-resistant material

**Figure 8 — Position of burner in front of specimen holder (side and front view)**

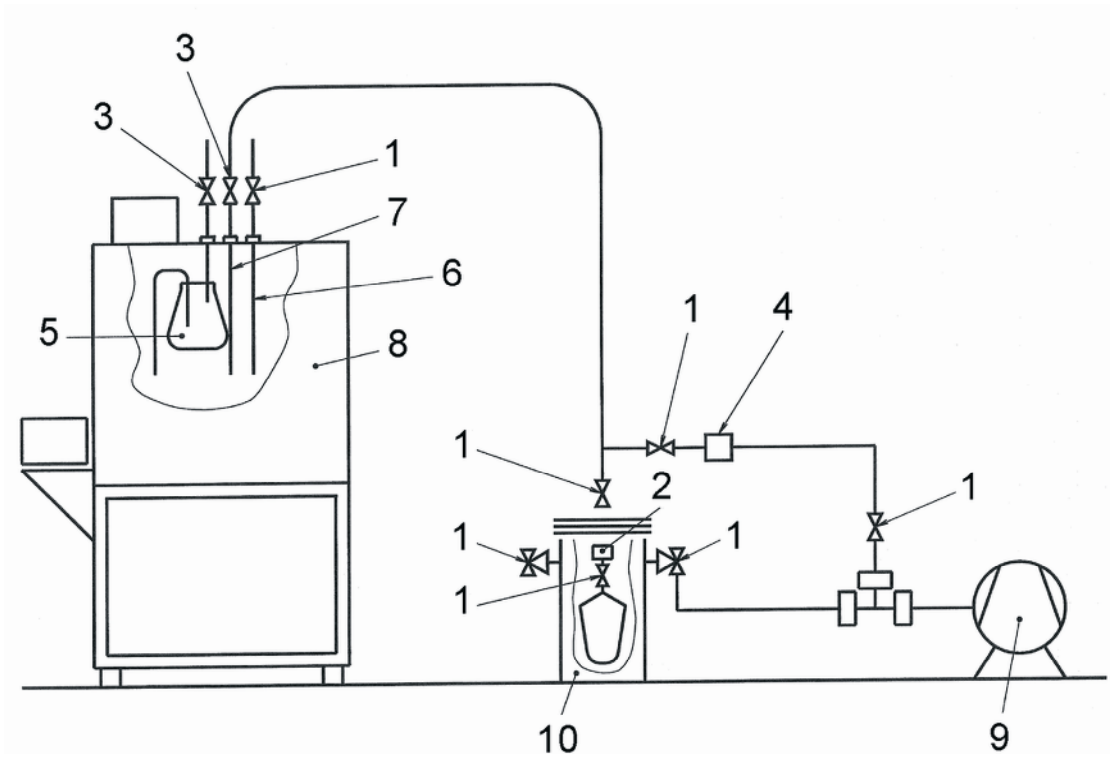

**Key**

- |                          |  |
|--------------------------|--|
| 1 Shut-off valve         | 6 Probe for direct measurement with colorimetric tube or second scrubber |
| 2 Quick release coupling | 7 Probe  |
| 3 Valve for gas sampling | 8 Combustion chamber   |
| 4 Coupling               | 9 Vacuum pump  |
| 5 Scrubber               | 10 Vacuum chamber  |

**Figure 9 — Gas sampling test set-up**

Dimensions in millimetres

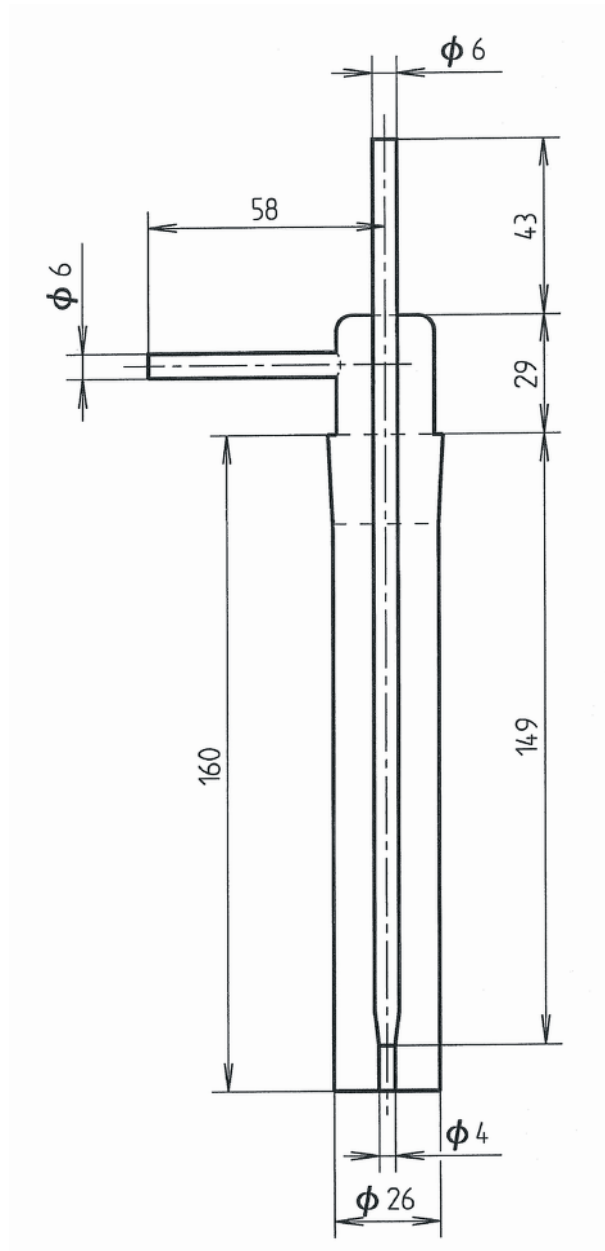

Figure 10 — Example of a scrubber



# British Standards Institution (BSI)

BSI is the national body responsible for preparing British Standards and other standards-related publications, information and services.

BSI is incorporated by Royal Charter. British Standards and other standardization products are published by BSI Standards Limited.

## About us

We bring together business, industry, government, consumers, innovators and others to shape their combined experience and expertise into standards-based solutions.

The knowledge embodied in our standards has been carefully assembled in a dependable format and refined through our open consultation process. Organizations of all sizes and across all sectors choose standards to help them achieve their goals.

## Information on standards

We can provide you with the knowledge that your organization needs to succeed. Find out more about British Standards by visiting our website at [bsigroup.com/standards](http://bsigroup.com/standards) or contacting our Customer Services team or Knowledge Centre.

## Buying standards

You can buy and download PDF versions of BSI publications, including British and adopted European and international standards, through our website at [bsigroup.com/shop](http://bsigroup.com/shop), where hard copies can also be purchased.

If you need international and foreign standards from other Standards Development Organizations, hard copies can be ordered from our Customer Services team.

## Subscriptions

Our range of subscription services are designed to make using standards easier for you. For further information on our subscription products go to [bsigroup.com/subscriptions](http://bsigroup.com/subscriptions).

With **British Standards Online (BSOL)** you'll have instant access to over 55,000 British and adopted European and international standards from your desktop. It's available 24/7 and is refreshed daily so you'll always be up to date.

You can keep in touch with standards developments and receive substantial discounts on the purchase price of standards, both in single copy and subscription format, by becoming a **BSI Subscribing Member**.

**PLUS** is an updating service exclusive to BSI Subscribing Members. You will automatically receive the latest hard copy of your standards when they're revised or replaced.

To find out more about becoming a BSI Subscribing Member and the benefits of membership, please visit [bsigroup.com/shop](http://bsigroup.com/shop).

With a **Multi-User Network Licence (MUNL)** you are able to host standards publications on your intranet. Licences can cover as few or as many users as you wish. With updates supplied as soon as they're available, you can be sure your documentation is current. For further information, email [bsmusales@bsigroup.com](mailto:bsmusales@bsigroup.com).

## BSI Group Headquarters

389 Chiswick High Road London W4 4AL UK

## Revisions

Our British Standards and other publications are updated by amendment or revision.

We continually improve the quality of our products and services to benefit your business. If you find an inaccuracy or ambiguity within a British Standard or other BSI publication please inform the Knowledge Centre.

## Copyright

All the data, software and documentation set out in all British Standards and other BSI publications are the property of and copyrighted by BSI, or some person or entity that owns copyright in the information used (such as the international standardization bodies) and has formally licensed such information to BSI for commercial publication and use. Except as permitted under the Copyright, Designs and Patents Act 1988 no extract may be reproduced, stored in a retrieval system or transmitted in any form or by any means – electronic, photocopying, recording or otherwise – without prior written permission from BSI. Details and advice can be obtained from the Copyright & Licensing Department.

## Useful Contacts:

### Customer Services

**Tel:** +44 845 086 9001

**Email (orders):** [orders@bsigroup.com](mailto:orders@bsigroup.com)

**Email (enquiries):** [cservices@bsigroup.com](mailto:cservices@bsigroup.com)

### Subscriptions

**Tel:** +44 845 086 9001

**Email:** [subscriptions@bsigroup.com](mailto:subscriptions@bsigroup.com)

### Knowledge Centre

**Tel:** +44 20 8996 7004

**Email:** [knowledgecentre@bsigroup.com](mailto:knowledgecentre@bsigroup.com)

### Copyright & Licensing

**Tel:** +44 20 8996 7070

**Email:** [copyright@bsigroup.com](mailto:copyright@bsigroup.com)



...making excellence a habit.™