

**Nuts, anchor, self  
locking, two lug,  
floating with  
counterbore —  
Classification:  
1 100 MPa/235 °C**

The European Standard EN 2754:2006 has the status of a  
British Standard

ICS 49.030.30

## National foreword

This British Standard is the official English language version of EN 2754:2006.

The UK participation in its preparation was entrusted to Technical Committee ACE/12, Aerospace fasteners and fastening systems, which has the responsibility to:

- aid enquirers to understand the text;
- present to the responsible international/European committee any enquiries on the interpretation, or proposals for change, and keep UK interests informed;
- monitor related international and European developments and promulgate them in the UK.

A list of organizations represented on this committee can be obtained on request to its secretary.

### Cross-references

The British Standards which implement international or European publications referred to in this document may be found in the *BSI Catalogue* under the section entitled “International Standards Correspondence Index”, or by using the “Search” facility of the *BSI Electronic Catalogue* or of British Standards Online.

This publication does not purport to include all the necessary provisions of a contract. Users are responsible for its correct application.

**Compliance with a British Standard does not of itself confer immunity from legal obligations.**

### Summary of pages

This document comprises a front cover, an inside front cover, the EN title page, pages 2 to 8, an inside back cover and a back cover.

The BSI copyright notice displayed in this document indicates when the document was last issued.

This British Standard was published under the authority of the Standards Policy and Strategy Committee on 31 May 2006

© BSI 2006

ISBN 0 580 48400 9

### Amendments issued since publication

Amd. No.	Date	Comments

---

ICS 49.030.30

English Version

Aerospace series - Nuts, anchor, self locking, two lug, floating  
with counterbore - Classification: 1 100 MPa/235 °C

Série aérospatiale - Écrous à river à freinage interne  
flottants, double patte avec chambrage - Classification : 1  
100 MPa/235 °C

Luft- und Raumfahrt - Gehäuse-Anniemuttern,  
selbstsichernd, beweglich, beiderseitiger Flansch mit  
zylindrischer Aussenkung - Klasse: 1 100 MPa/235 °C

This European Standard was approved by CEN on 9 March 2006.

CEN members are bound to comply with the CEN/CENELEC Internal Regulations which stipulate the conditions for giving this European Standard the status of a national standard without any alteration. Up-to-date lists and bibliographical references concerning such national standards may be obtained on application to the Central Secretariat or to any CEN member.

This European Standard exists in three official versions (English, French, German). A version in any other language made by translation under the responsibility of a CEN member into its own language and notified to the Central Secretariat has the same status as the official versions.

CEN members are the national standards bodies of Austria, Belgium, Cyprus, Czech Republic, Denmark, Estonia, Finland, France, Germany, Greece, Hungary, Iceland, Ireland, Italy, Latvia, Lithuania, Luxembourg, Malta, Netherlands, Norway, Poland, Portugal, Romania, Slovakia, Slovenia, Spain, Sweden, Switzerland and United Kingdom.



EUROPEAN COMMITTEE FOR STANDARDIZATION  
COMITÉ EUROPÉEN DE NORMALISATION  
EUROPÄISCHES KOMITEE FÜR NORMUNG

Management Centre: rue de Stassart, 36 B-1050 Brussels

<b>Contents</b>		Page
Foreword .....		3
1	Scope .....	4
2	Normative references .....	4
3	Required characteristics .....	5
4	Designation .....	8
5	Marketing .....	8
6	Technical specification.....	8

## **Foreword**

This European Standard (EN 2754:2006) has been prepared by the European Association of Aerospace Manufacturers - Standardization (AECMA-STAN).

After enquiries and votes carried out in accordance with the rules of this Association, this Standard has received the approval of the National Associations and the Official Services of the member countries of AECMA, prior to its presentation to CEN.

This European Standard shall be given the status of a national standard, either by publication of an identical text or by endorsement, at the latest by October 2006, and conflicting national standards shall be withdrawn at the latest by October 2006.

Attention is drawn to the possibility that some of the elements of this document may be the subject of patent rights. CEN [and/or CENELEC] shall not be held responsible for identifying any or all such patent rights.

According to the CEN/CENELEC Internal Regulations, the national standards organizations of the following countries are bound to implement this European Standard: Austria, Belgium, Cyprus, Czech Republic, Denmark, Estonia, Finland, France, Germany, Greece, Hungary, Iceland, Ireland, Italy, Latvia, Lithuania, Luxembourg, Malta, Netherlands, Norway, Poland, Portugal, Romania, Slovakia, Slovenia, Spain, Sweden, Switzerland and the United Kingdom.

## 1 Scope

This standard specifies the characteristics of two lug, counterbored, floating anchor nuts, with a self-locking feature achieved by forming the upper portion out-of-round, the dimensions of which are in conformity with ISO 3209.

These nuts are intended for use in aircraft assemblies, in which the fasteners are mainly subjected to shear loads. The counterbore of nuts with thread diameter equal to or greater than 4 mm is deep enough to accommodate a bolt shank in excess of assembly thickness, as well as the incomplete threads.

The 3 mm diameter nut has no counterbore.

They are intended to be used with threaded parts of 1 100 MPa <sup>1)</sup> tensile strength classification.

The cadmium plating restricts the application to temperatures not exceeding 235 °C.

## 2 Normative references

The following referenced documents are indispensable for the application of this document. For dated references, only the edition cited applies. For undated references, the latest edition of the referenced document (including any amendments) applies.

ISO 3209, *Aerospace — Nuts, anchor, self-locking, floating, two lug, with counterbore, with MJ threads, classifications: 1 100 MPa (at ambient temperature )/235 °C, 1 100 MPa (at ambient temperature )/315 °C and 1 100 MPa (at ambient temperature)/425 °C — Dimensions.*

ISO 5855-1, *Aerospace — MJ threads — Part 1: General requirements.*

ISO 5855-2, *Aerospace — MJ threads — Part 2: Limit dimensions for bolts and nuts.*

ISO 5858, *Aerospace — Nuts, self-locking, with maximum operating temperature less than or equal to 425 °C — Procurement specification.*

ISO 8788, *Aerospace — Nuts, metric — Tolerances of form and position.*

EN 2133, *Aerospace series — Cadmium plating of steels with specified tensile strength  $\leq 1\,450$  MPa, copper, copper alloys and nickel alloys.*

EN 2424, *Aerospace series — Marking of aerospace products.*

EN 2491, *Aerospace series — Molybdenum disulphide dry lubricants — Coating methods.*

EN 2542, *Aerospace series — Steel FE-PL43S — Annealed — Bar and wire —  $D_e \leq 40$  mm — for prevailing torque nuts.* <sup>2)</sup>

EN 2543, *Aerospace series — Steel FE-PL43S — Annealed — Sheet and strip —  $0,3 \leq a \leq 2$  mm — for prevailing torque nuts.* <sup>2)</sup>

EN 9100, *Aerospace series — Quality management systems — Requirements (based on ISO 9001:2000) and Quality systems — Model for quality assurance in design, development, production, installation and servicing (based on ISO 9001:1994).*

---

1) This strength class applies at room temperatures.

2) Published as AECMA Prestandard at the date of publication of this standard.

### **3 Required characteristics**

#### **3.1 Configuration – Dimensions – Tolerances**

The configuration shall be in accordance with Figure 1; the dimensions and tolerances shall conform to the values shown in Figure 1 and Table 1, before cadmium plating and MoS<sub>2</sub> lubrication.

#### **3.2 Surface roughness**

See Figure 1. The values apply before cadmium plating and MoS<sub>2</sub> lubrication.

They do not apply to the thread, sheared-off edges and punched holes obtained by common manufacturing processes.

#### **3.3 Materials**

Steel EN 2542 or EN 2543.

#### **3.4 Surface treatment**

Cadmium plating EN 2133, 5 µm minimum on the threads and all areas which can be contacted by a 20 mm diameter ball. On all other areas, a continuous deposit shall be present, but no minimum value is specified.

Lubrication by MoS<sub>2</sub> EN 2491, mandatory on threads, optional on other surfaces.

6,3 / [0,8]

Break sharp edges 0,1 mm to 0,4 mm

Float included

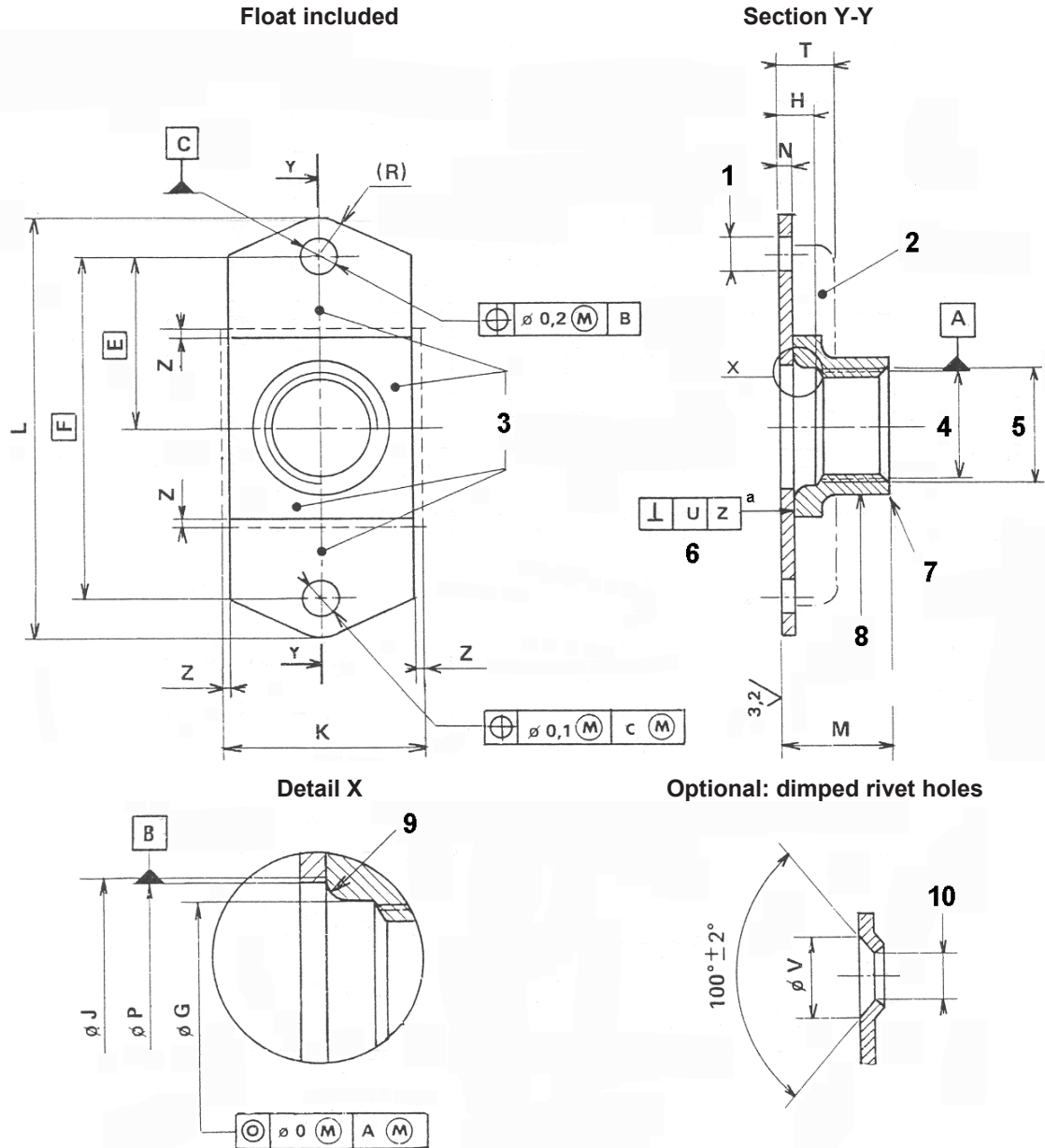

**Key**

- |  |   |
|--|---|
| <p>1 2 holes <math>\varnothing S +0,2_0</math>; Plain rivet holes</p> <p>2 Cage</p> <p>3 Part marking in these areas</p> <p>4 Pitch <math>\varnothing</math></p> <p>5 Threads</p> <p>6 Applicable over a diameter equal to the width of the threaded element</p> | <p>7 Form out-of-round in this area to achieve the self-locking torque requirement (tool marks permissible)</p> <p>8 Threaded element</p> <p>9 Radius or chamfer</p> <p>10 2 holes <math>\varnothing S +0,4_0</math>; Dimpled rivet holes</p> <p>a For inspection requirements, see Clause 6.</p> |
|--|---|

Details of form, not stated, are at the manufacturer's option.

**Figure 1 — Configuration**



Table 1 — Dimensions

Dimensions in millimetres

Diamètre code	Thread <sup>a</sup>	<i>E</i>	<i>F</i>	<i>G</i>	<i>H</i>	<i>J</i> <sup>b</sup>	<i>K</i>	<i>L</i>	<i>M</i>
				min.	min.	max.	max.	max.	max.
030	MJ 3 × 0,50 – 4H 6H	8,5	17	c	c	4,6	11	23,2	4
040	MJ 4 × 0,70 – 4H 6H	8,5	17	4,4	2,2	6,2	11	23,2	5,8
050	MJ 5 × 0,80 – 4H 6H	9,5	19	5,5	2,4	7,3	12	25,2	6,9
060	MJ 6 × 1,00 – 4H 5H	11	22	6,5	2,7	8,7	13,5	29,2	8,1
080	MJ 8 × 1,00 – 4H 5H	11	22	8,5	2,7	10,9	16	29,2	9,9
100	MJ 10 × 1,25 – 4H 5H	13	26	10,5	3	12,9	18	35,2	12

Diamètre code	<i>N</i> <sup>d</sup>	<i>P</i>	<i>R</i> aux.	<i>S</i>	<i>T</i>	<i>U</i>	<i>V</i>	<i>Z</i> Radial float	<b>Mass</b> kg/1 000 pieces
	max.	min.			max.		± 0,25	min.	max.
030	0,9	4,5	3	2,5	4,5	0,15	4,8	0,5	1,8
040	0,9	5,5	3	2,5	4,5	0,15	4,8	0,5	2
050	0,9	6,5	3	2,5	4,5	0,18	4,8	0,7	2,3
060	0,9	7,5	3,5	2,5	4,6	0,18	4,8	0,7	3,8
080	1,1	9,5	3,5	3	5,5	0,20	5,7	0,75	7,3
100	1,1	11,5	4,5	3,5	6	0,23	6,6	0,75	10

Tolerances of form and position are in conformity with ISO 8788.

<sup>a</sup> In conformity with ISO 5855 parts 1 and 2. In the self-locking zone, the tolerances apply before deformation.

<sup>b</sup>  $\varnothing J$  is to be measured at sharp corners (chamfered) or point of tangency (radiused)

<sup>c</sup> The 3 mm diameter nut does not include a counterbore.

<sup>d</sup> Dimension *N* is the lug thickness at the rivet hole location.

#### **4 Designation**

Each nut shall only be designated as in the following example.

EXAMPLE

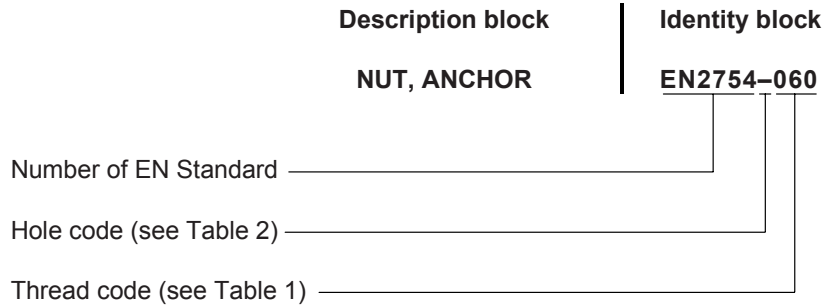

**Table 2**

<b>Option</b>	<b>Hole code</b>
Plain rivet holes	–
Dimpled rivet holes	K

NOTE If necessary, the code I9005 shall be placed between the description block and the identity block.

#### **5 Marketing**

Each nut shall be marked in any of the positions shown on Figure 1 in accordance with EN 2424, Style F.

#### **6 Technical specification**

Conforming to ISO 5858 except for quality assurance requirements – See EN 9100.



---

---

## BSI — British Standards Institution

BSI is the independent national body responsible for preparing British Standards. It presents the UK view on standards in Europe and at the international level. It is incorporated by Royal Charter.

### Revisions

British Standards are updated by amendment or revision. Users of British Standards should make sure that they possess the latest amendments or editions.

It is the constant aim of BSI to improve the quality of our products and services. We would be grateful if anyone finding an inaccuracy or ambiguity while using this British Standard would inform the Secretary of the technical committee responsible, the identity of which can be found on the inside front cover.  
Tel: +44 (0)20 8996 9000. Fax: +44 (0)20 8996 7400.

BSI offers members an individual updating service called PLUS which ensures that subscribers automatically receive the latest editions of standards.

### Buying standards

Orders for all BSI, international and foreign standards publications should be addressed to Customer Services. Tel: +44 (0)20 8996 9001.  
Fax: +44 (0)20 8996 7001. Email: [orders@bsi-global.com](mailto:orders@bsi-global.com). Standards are also available from the BSI website at <http://www.bsi-global.com>.

In response to orders for international standards, it is BSI policy to supply the BSI implementation of those that have been published as British Standards, unless otherwise requested.

### Information on standards

BSI provides a wide range of information on national, European and international standards through its Library and its Technical Help to Exporters Service. Various BSI electronic information services are also available which give details on all its products and services. Contact the Information Centre.  
Tel: +44 (0)20 8996 7111. Fax: +44 (0)20 8996 7048. Email: [info@bsi-global.com](mailto:info@bsi-global.com).

Subscribing members of BSI are kept up to date with standards developments and receive substantial discounts on the purchase price of standards. For details of these and other benefits contact Membership Administration.  
Tel: +44 (0)20 8996 7002. Fax: +44 (0)20 8996 7001.  
Email: [membership@bsi-global.com](mailto:membership@bsi-global.com).

Information regarding online access to British Standards via British Standards Online can be found at <http://www.bsi-global.com/bsonline>.

Further information about BSI is available on the BSI website at <http://www.bsi-global.com>.

### Copyright

Copyright subsists in all BSI publications. BSI also holds the copyright, in the UK, of the publications of the international standardization bodies. Except as permitted under the Copyright, Designs and Patents Act 1988 no extract may be reproduced, stored in a retrieval system or transmitted in any form or by any means – electronic, photocopying, recording or otherwise – without prior written permission from BSI.

This does not preclude the free use, in the course of implementing the standard, of necessary details such as symbols, and size, type or grade designations. If these details are to be used for any other purpose than implementation then the prior written permission of BSI must be obtained.

Details and advice can be obtained from the Copyright & Licensing Manager.  
Tel: +44 (0)20 8996 7070. Fax: +44 (0)20 8996 7553.  
Email: [copyright@bsi-global.com](mailto:copyright@bsi-global.com).