

Eurocode 7: Geotechnical design —

Part 1: General rules

ICS 91.010.30; 93.020

National foreword

This British Standard is the UK implementation of EN 1997-1:2004+A1:2013, incorporating corrigendum February 2009. It supersedes BS EN 1997-1:2004, which is withdrawn.

The start and finish of text introduced or altered by corrigendum is indicated in the text by tags. Text altered by CEN corrigendum February 2009 is indicated in the text by AC1 AC1.

The start and finish of text introduced or altered by amendment is indicated in the text by tags. Tags indicating changes to CEN text carry the number of the CEN amendment. For example, text altered by CEN amendment A1 is indicated by A1 A1.

EN 1997-1 was published as a British Standard in 2004, and the UK National Annex was added in 2007. Part 2 of Eurocode 7, EN 1997-2 was published in 2007 followed by its UK National Annex in 2009. Older related British Standards have been withdrawn or revised as noted below. The Department for Communities and Local Government (DCLG) published a letter, dated 29 January 2010, which explains how this relates to Building Regulations in England and Wales and discusses the use of both current and withdrawn standards (<http://www.communities.gov.uk/documents/planningandbuilding/pdf/1454859.pdf>). Only BS EN 1997 Parts 1 and 2 are listed under “Geotechnical work and foundations” in UK Building Regulations Approved Document A, as amended in 2013.

The following British Standards were withdrawn on 31 March 2010:

- BS 8002:1994, *Code of practice for earth retaining structures*;
- BS 8004:1986, *Code of practice for foundations*.

Withdrawal means that these documents are no longer current British Standards and are not maintained by BSI, though they will remain available for purchase. It is planned that extensively revised versions of BS 8002 and BS 8004 will be published in 2015.

The following British Standards have been retained after extensive revision to update them and make them more compatible with Eurocodes:

- BS 5930:1999+A2:2010, *Code of practice for site investigations*;
- BS 6031:2009, *Code of practice for earthworks*;
- BS 8006-1:2010, *Code of practice for strengthened/reinforced soils and other fills*;
- BS 8006-2:2011, *Code of practice for strengthened/reinforced soils – Part 2: Soil nail design*.

It is possible that further changes will be made to these standards, or they could be withdrawn, depending on future development of Eurocodes. (The letter of DCLG dated 29 January 2010 incorrectly states that BS 8006:1995 was to be withdrawn on 31 March 2010. BS 8006:1995 was withdrawn on 31 December 2011.)

This British Standard was published under the authority of the Standards Policy and Strategy Committee on 22 December 2004

© The British Standards Institution 2014.
Published by BSI Standards Limited 2014

Amendments/corrigenda issued since publication

Date	Comments
31 January 2010	Implementation of CEN corrigendum February 2009
31 July 2014	Implementation of CEN amendment A1:2013

The following British Standards remain current:

- BS 8081:1989, *Code of practice for ground anchorages*.

(The letter of DCLG dated 29 January 2010 incorrectly states that this standard was to be withdrawn on 31 March 2010.) It is planned that an extensively revised version of BS 8081 will be published in 2015.

- BS 8008:1996+A1:2008, *Safety precautions and procedures for the construction and descent of machine-bored shafts for piling and other purposes*.

The usage of BS 8081:1989 is limited, as noted in the National Annex. BS 8008:1996 contains non-contradictory complementary information as stated in the National Annex.

The UK participation in its preparation was entrusted to Technical Committee B/526, Geotechnics.

A list of organizations represented on this committee can be obtained on request to its secretary.

Where a normative part of this EN allows for a choice to be made at the national level, the range and possible choice will be given in the normative text, and a note will qualify it as a Nationally Determined Parameter (NDP). NDPs can be a specific value for a factor, a specific level or class, a particular method or a particular application rule if several are proposed in the EN.

To enable EN 1997-1 to be used in the UK, the NDPs are published in the National Annex.

The publication does not purport to include all the necessary provisions of a contract. Users are responsible for its correct application.

Compliance with a British Standard cannot confer immunity from legal obligations.

ICS 91.120.20

English version

Eurocode 7: Geotechnical design - Part 1: General rules

Eurocode 7: Calcul géotechnique - Partie 1: Règles
générales

Eurocode 7: Entwurf, Berechnung und Bemessung in der
Geotechnik - Teil 1: Allgemeine Regeln

This European Standard was approved by CEN on 23 April 2004.

CEN members are bound to comply with the CEN/CENELEC Internal Regulations which stipulate the conditions for giving this European Standard the status of a national standard without any alteration. Up-to-date lists and bibliographical references concerning such national standards may be obtained on application to the Central Secretariat or to any CEN member.

This European Standard exists in three official versions (English, French, German). A version in any other language made by translation under the responsibility of a CEN member into its own language and notified to the Central Secretariat has the same status as the official versions.

CEN members are the national standards bodies of Austria, Belgium, Cyprus, Czech Republic, Denmark, Estonia, Finland, France, Germany, Greece, Hungary, Iceland, Ireland, Italy, Latvia, Lithuania, Luxembourg, Malta, Netherlands, Norway, Poland, Portugal, Slovakia, Slovenia, Spain, Sweden, Switzerland and United Kingdom.



EUROPEAN COMMITTEE FOR STANDARDIZATION
COMITÉ EUROPÉEN DE NORMALISATION
EUROPÄISCHES KOMITEE FÜR NORMUNG

Management Centre: rue de Stassart, 36 B-1050 Brussels

Contents

Foreword	5
Section 1 General	9
1.1 Scope	9
1.2 Normative references.....	10
1.3 Assumptions.....	11
1.4 Distinction between Principles and Application Rules.....	11
1.5 Definitions.....	12
1.6 Symbols.....	13
Section 2 Basis of geotechnical design	20
2.1 Design requirements.....	20
2.2 Design situations.....	22
2.3 Durability	23
2.4 Geotechnical design by calculation	24
2.5 Design by prescriptive measures	36
2.6 Load tests and tests on experimental models.....	37
2.7 Observational method.....	37
2.8 Geotechnical Design Report.....	37
Section 3 Geotechnical data	39
3.1 General.....	39
3.2 Geotechnical investigations.....	39
3.3 Evaluation of geotechnical parameters	40
3.4 Ground Investigation Report.....	48
Section 4 Supervision of construction, monitoring and maintenance	50
4.1 General.....	50
4.2 Supervision.....	50
4.3 Checking ground conditions	52
4.4 Checking construction.....	53
4.5 Monitoring.....	54
4.6 Maintenance.....	55
Section 5 Fill, dewatering, ground improvement and reinforcement	56
5.1 General.....	56
5.2 Fundamental requirements.....	56
5.3 Fill construction	56
5.4 Dewatering	60
5.5 Ground improvement and reinforcement	61
Section 6 Spread foundations	62
6.1 General.....	62
6.2 Limit states	62
6.3 Actions and design situations	62
6.4 Design and construction considerations.....	62
6.5 Ultimate limit state design.....	63
6.6 Serviceability limit state design.....	66
6.7 Foundations on rock; additional design considerations	68
6.8 Structural design of spread foundations.....	69
6.9 Preparation of the subsoil.....	69
Section 7 Pile foundations	71
7.1 General.....	71
7.2 Limit states	71
7.3 Actions and design situations	71

7.4	Design methods and design considerations	73
7.5	Pile load tests	75
7.6	Axially loaded piles.....	77
7.7	Transversely loaded piles	87
7.8	Structural design of piles.....	89
7.9	Supervision of construction.....	89
Section 8	Ⓐ₁ Anchors Ⓐ₁	92
8.1	General.....	92
8.2	Limit states	93
8.3	Design situations and actions	94
8.4	Design and construction considerations.....	94
8.5	Ⓐ ₁ Limit state design of anchors	95
8.6	Tests on anchors	97
8.7	Lock-off load for pre-stressed anchors	98
8.8	Supervision, monitoring and maintenance Ⓐ ₁	98
Section 9	Retaining structures.....	99
9.1	General.....	99
9.2	Limit states	99
9.3	Actions, geometrical data and design situations	100
9.4	Design and construction considerations.....	103
9.5	Determination of earth pressures	104
9.6	Water pressures	107
9.7	Ultimate limit state design	107
9.8	Serviceability limit state design.....	111
Section 10	Hydraulic failure	113
10.1	General.....	113
10.2	Failure by uplift.....	114
10.3	Failure by heave.....	116
10.4	Internal erosion	116
10.5	Failure by piping.....	117
Section 11	Overall stability	119
11.1	General.....	119
11.2	Limit states	119
11.3	Actions and design situations	119
11.4	Design and construction considerations.....	120
11.5	Ultimate limit state design	121
11.6	Serviceability limit state design.....	123
11.7	Monitoring.....	123
Section 12	Embankments.....	125
12.1	General.....	125
12.2	Limit states	125
12.3	Actions and design situations	125
12.4	Design and construction considerations.....	126
12.5	Ultimate limit state design	127
12.6	Serviceability limit state design.....	128
12.7	Supervision and monitoring	128
Annex A (normative)	Partial and correlation factors for ultimate Ⓐ₁ and serviceability limit Ⓐ₁ states and recommended values	130
Annex B (informative)	Background information on partial factors for Design Approaches 1, 2 and 3	140
Annex C (informative)	Sample procedures to determine limit values of earth pressures on vertical walls	143
Annex D (informative)	A sample analytical method for bearing resistance calculation	159

Annex E (informative) A sample semi-empirical method for bearing resistance estimation.....	162
Annex F (informative) Sample methods for settlement evaluation	163
Annex G (informative) A sample method for deriving presumed bearing resistance for spread foundations on rock.....	165
Annex H (informative) Limiting values of structural deformation and foundation movement.....	167
Annex J (informative) Checklist for construction supervision and performance monitoring.....	169

Foreword

This document (EN 1997-1) has been prepared by Technical Committee CEN/TC250 “Structural Eurocodes”, the secretariat of which is held by BSI. CEN/TC 250 is responsible for all Structural Eurocodes.

This European Standard shall be given the status of a national standard, either by publication of an identical text, or by endorsement, at the latest by **May 2005** and conflicting national standards shall be withdrawn by **March 2010**.

This document supersedes ENV 1997-1:1994.

According to the CEN/CENELEC Internal Regulations, the national standards organizations of the following countries are bound to implement this European Standard: Austria, Belgium, Cyprus, Czech Republic, Denmark, Estonia, Finland, France, Germany, Greece, Hungary, Iceland, Ireland, Italy, Latvia, Lithuania, Luxembourg, Malta, Netherlands, Norway, Poland, Portugal, Slovakia, Slovenia, Spain, Sweden, Switzerland and United Kingdom.

Foreword to amendment A1

This document (EN 1997-1:2004/A1:2013) has been prepared by Technical Committee CEN/TC 250 “Structural Eurocodes”, the secretariat of which is held by BSI.

This Amendment to the European Standard EN 1997-1:2004 shall be given the status of a national standard, either by publication of an identical text or by endorsement, at the latest by November 2014, and conflicting national standards shall be withdrawn at the latest by November 2014.

Attention is drawn to the possibility that some of the elements of this document may be the subject of patent rights. CEN shall not be held responsible for identifying any or all such patent rights.

According to the CEN-CENELEC Internal Regulations, the national standards organizations of the following countries are bound to implement this European Standard: Austria, Belgium, Bulgaria, Croatia, Cyprus, Czech Republic, Denmark, Estonia, Finland, Former Yugoslav Republic of Macedonia, France, Germany, Greece, Hungary, Iceland, Ireland, Italy, Latvia, Lithuania, Luxembourg, Malta, Netherlands, Norway, Poland, Portugal, Romania, Slovakia, Slovenia, Spain, Sweden, Switzerland, Turkey and the United Kingdom.

Background to the Eurocode programme

In 1975, the Commission of the European Community decided on an action programme in the field of construction, based on article 95 of the Treaty. The objective of the programme was the elimination of technical obstacles to trade and the harmonisation of technical specifications.

Within this action programme, the Commission took the initiative to establish a set of harmonised technical rules for the design of construction works which, in a first stage, would serve as an alternative to the national rules in force in the Member States and, ultimately, would replace them.

For fifteen years, the Commission, with the help of a Steering Committee with Representatives of Member States, conducted the development of the Eurocodes programme, which led to the first generation of European codes in the 1980s.

In 1989, the Commission and the Member States of the EU and EFTA decided, on the basis of an agreement¹ between the Commission and CEN, to transfer the preparation and the publication of the Eurocodes to CEN through a series of Mandates, in order to provide them with a future status of European Standard (EN). This links *de facto* the Eurocodes with the provisions of all the Council's Directives and/or Commissions Decisions dealing with European standards (e.g. the Council Directive 89/106/EEC on construction products - CPD - and Council Directives 93/37/EEC, 92/50/EEC and 89/440/EEC on public works and services and equivalent EFTA Directives initiated in pursuit of setting up the internal market).

The Structural Eurocode programme comprises the following standards generally consisting of a number of Parts:

EN 1990	Eurocode :	Basis of Structural Design
EN 1991	Eurocode 1:	Actions on structures
EN 1992	Eurocode 2:	Design of concrete structures
EN 1993	Eurocode 3:	Design of steel structures
EN 1994	Eurocode 4:	Design of composite steel and concrete structures
EN 1995	Eurocode 5:	Design of timber structures
EN 1996	Eurocode 6:	Design of masonry structures
EN 1997	Eurocode 7:	Geotechnical design
EN 1998	Eurocode 8:	Design of structures for earthquake resistance
EN 1999	Eurocode 9:	Design of aluminium structures

Eurocode standards recognise the responsibility of regulatory authorities in each Member State and have safeguarded their right to determine values related to regulatory safety matters at national level where these continue to vary from State to State.

Status and field of application of Eurocodes

The Member States of the EU and EFTA recognise that Eurocodes serve as reference documents for the following purposes:

- as a means to prove compliance of building and civil engineering works with the essential requirements of Council Directive 89/106/EEC, particularly Essential Requirement N°1 – Mechanical resistance and stability – and Essential Requirement N°2 – Safety in case of fire;
- as a basis for specifying contracts for construction works and related engineering services;
- as a framework for drawing up harmonised technical specifications for construction products (ENs and ETAs)

¹ Agreement between the Commission of the European Communities and the European Committee for Standardisation (CEN) concerning the work on EUROCODES for the design of building and civil engineering works (BC/CEN/03/89).

The Eurocodes, as far as they concern the construction works themselves, have a direct relationship with the Interpretative Documents² referred to in Article 12 of the CPD, although they are of a different nature from harmonised product standards³. Therefore, technical aspects arising from the Eurocodes work need to be adequately considered by CEN Technical Committees and/or EOTA Working Groups working on product standards with a view to achieving full compatibility of these technical specifications with the Eurocodes.

The Eurocode standards provide common structural design rules for everyday use for the design of whole structures and component products of both a traditional and an innovative nature. Unusual forms of construction or design conditions are not specifically covered and additional expert consideration will be required by the designer in such cases.

National Standards implementing Eurocodes

The National Standards implementing Eurocodes will comprise the full text of the Eurocode (including any annexes), as published by CEN, which may be preceded by a National title page and National foreword, and may be followed by a National annex.

The National annex may only contain information on those parameters, which are left open in the Eurocode for national choice, known as Nationally Determined Parameters, to be used for the design of buildings and civil engineering works to be constructed in the country concerned, i.e. :

- values and/or classes where alternatives are given in the Eurocode,
- values to be used where a symbol only is given in the Eurocode,
- country specific data (geographical, climatic), e.g. snow map,
- the procedure to be used where alternative procedures are given in the Eurocode.

It may also contain:

- decisions on the application of informative annexes,
- references to non-contradictory complementary information to assist the user to apply the Eurocode.

Links between Eurocodes and harmonised technical specifications (ENs and ETAs) for products

There is a need for consistency between the harmonised technical specifications for construction products and the technical rules for works⁴. Furthermore, all the information accompanying the CE Marking of the construction products, which refer to Eurocodes should clearly mention which Nationally Determined Parameters have been taken into account.

² According to Art. 3.3 of the CPD, the essential requirements (ERs) shall be given concrete form in interpretative documents for the creation of the necessary links between the essential requirements and the mandates for harmonised ENs and ETAGs/ETAs.

³ According to Art. 12 of the CPD the interpretative documents shall :

- a) give concrete form to the essential requirements by harmonising the terminology and the technical bases and indicating classes or levels for each requirement where necessary ;
 - b) indicate methods of correlating these classes or levels of requirement with the technical specifications, e.g. methods of calculation and of proof, technical rules for project design, etc. ;
 - c) serve as a reference for the establishment of harmonised standards and guidelines for European technical approvals.
- The Eurocodes, *de facto*, play a similar role in the field of the ER 1 and a part of ER 2.

⁴ see Art.3.3 and Art.12 of the CPD, as well as clauses 4.2, 4.3.1, 4.3.2 and 5.2 of ID 1.

Additional information specific to Eurocode 7

EN 1997-1 gives design guidance and actions for geotechnical design of buildings and civil engineering works.

EN 1997-1 is intended for clients, designers, contractors and public authorities.

EN 1997-1 is intended to be used with EN 1990 and EN 1991 to EN 1999.

In using EN 1997-1 in practice, particular regard should be paid to the underlying assumptions and conditions given in 1.3.

The 12 sections of EN 1997-1 are complemented by 1 normative and 8 informative annexes.

National annex for EN 1997-1

This standard gives alternative procedures and recommended values with notes indicating where national choices may have to be made. Therefore the National Standard implementing EN 1997-1 should have a National annex containing all Nationally Determined Parameters to be used for the design of buildings and civil engineering works to be constructed in the relevant country.

National choice is allowed in EN 1997-1 through the following paragraphs:

- 2.1(8)P, 2.4.6.1(4)P, 2.4.6.2(2)P, 2.4.7.1(2)P, 2.4.7.1(3), AC1 2.4.7.1(4), 2.4.7.1(5), 2.4.7.1(6), AC1 2.4.7.2(2)P, 2.4.7.3.2(3)P, 2.4.7.3.3(2)P, 2.4.7.3.4.1(1)P, 2.4.7.4(3)P, 2.4.7.5(2)P, 2.4.8(2), 2.4.9(1)P, 2.5(1), 7.6.2.2(8)P, 7.6.2.2(14)P, 7.6.2.3(4)P, 7.6.2.3(5)P, 7.6.2.3(8), 7.6.2.4(4)P, 7.6.3.2(2)P, 7.6.3.2(5)P, 7.6.3.3(3)P, 7.6.3.3(4)P, 7.6.3.3(6), A1 8.4(6)P, 8.4(7)P, 8.5.1(1)P, 8.5.1(2)P, 8.5.2(1)P, 8.5.2(2)P, 8.5.2(3)P, 8.5.2(5)P, 8.5.3(1)P, 8.5.3(2)P, 8.5.3(3)P, 8.5.3(4)P, 8.6.2(2)P, 8.6.2(3)P, A1 AC1 10.2(3), AC1 11.5.1(1)P

and the following clauses in annex A:

- A.2
- A.3.1, A.3.2, A.3.3.1, A.3.3.2, A.3.3.3, A1 *Text deleted* A1 A.3.3.5, A.3.3.6,
- A.4
- A.5
- A1 — A.6 A1

Section 1 General

1.1 Scope

1.1.1 Scope of EN 1997

(1) EN 1997 is intended to be used in conjunction with EN 1990:2002, which establishes the principles and requirements for safety and serviceability, describes the basis of design and verification and gives guidelines for related aspects of structural reliability.

(2) EN 1997 is intended to be applied to the geotechnical aspects of the design of buildings and civil engineering works. It is subdivided into various separate parts (see 1.1.2 and 1.1.3).

(3) EN 1997 is concerned with the requirements for strength, stability, serviceability and durability of structures. Other requirements, e.g. concerning thermal or sound insulation, are not considered.

(4) Numerical values of actions on buildings and civil engineering works to be taken into account in design are provided in EN 1991 for the various types of construction. Actions imposed by the ground, such as earth pressures, shall be calculated according to the rules of EN 1997.

(5) Separate European Standards are intended to be used to treat matters of execution and workmanship. They are denoted in the relevant sections.

(6) In EN 1997 execution is covered to the extent that is necessary to comply with the assumptions of the design rules.

(7) EN 1997 does not cover the special requirements of seismic design. EN 1998 provides additional rules for geotechnical seismic design, which complete or adapt the rules of this Standard.

1.1.2 Scope of EN 1997-1

(1) EN 1997-1 is intended to be used as a general basis for the geotechnical aspects of the design of buildings and civil engineering works.

(2) The following subjects are dealt with in EN 1997-1:

Section 1: General

Section 2: Basis of geotechnical design

Section 3: Geotechnical data

Section 4: Supervision of construction, monitoring and maintenance

Section 5: Fill, dewatering, ground improvement and reinforcement

Section 6: Spread foundations

Section 7: Pile foundations

Section 8: Anchors

Section 9: Retaining structures

Section 10: Hydraulic failure

Section 11: Overall stability

Section 12: Embankments

(3) EN 1997-1 is accompanied by Annexes A to J, which provide:

- in A: recommended γ_{AC1} partial factor γ_{AC1} values; different values of the partial factors may be set by the National annex;
- in B to J: supplementary informative guidance such as internationally applied calculation methods.

1.1.3 Further Parts of EN 1997

(1) EN 1997-1 is supplemented by EN 1997-2 that provides requirements for the performance and evaluation of field and laboratory testing.

1.2 Normative references

(1) This European Standard incorporates by dated or undated reference, provisions from other publications. These normative references are cited at the appropriate places in the text and the publications are listed hereafter. For dated references, subsequent amendments to or revisions of any of these publications apply to this European Standard only when incorporated in it by amendment or revision. For undated references the latest edition of the publication referred to applies (including amendments).

NOTE The Eurocodes were published as European Prestandards. The following European Standards which are published or in preparation are cited in normative clauses

EN 1990:2002	Eurocode: Basis of structural design
EN 1991	Eurocode 1 Actions on structures
EN 1991-4	Eurocode 1 Actions on structures - Part 4 Actions in silos and tanks
EN 1992	Eurocode 2 Design of concrete structures
γ_{A1} EN 1992-1-1:2004	Eurocode 2: Design of concrete structures – Part 1-1: General rules and rules for buildings γ_{A1}
EN 1993	Eurocode 3 Design of steel structures
EN 1994	Eurocode 4 Design of composite steel and concrete structures
EN 1995	Eurocode 5 Design of timber structures
EN 1996	Eurocode 6 Design of masonry structures
EN 1997-2	Eurocode 7 Geotechnical design - Part 2: Ground investigation and testing
EN 1998	Eurocode 8 Design of structures for earth quake resistance
EN 1999	Eurocode 9 Design of aluminium and aluminium alloy structures
EN 1536:1999	Execution of special geotechnical work: Bored piles
γ_{A1} EN 1537	Execution of special geotechnical work; Ground anchors γ_{A1}
EN 12063:1999	Execution of special geotechnical work; Sheet-pile walls

EN 12699:2000	Execution of special geotechnical work; Displacement piles
EN 14199	Execution of special geotechnical works – Micropiles
EN-ISO 13793: 2001	Thermal performance of buildings –Thermal design of foundations to avoid frost heave
A1 EN ISO 22477-5	Geotechnical investigation and testing – testing of geotechnical structures – Part 5:Testing of anchors (in preparation) A1

1.3 Assumptions

(1) Reference is made to 1.3 of EN 1990:2002.

(2) The provisions of this standard are based on the assumptions given below:

- data required for design are collected, recorded and interpreted by appropriately qualified personnel;
- structures are designed by appropriately qualified and experienced personnel;
- adequate continuity and communication exist between the personnel involved in data-collection, design and construction;
- adequate supervision and quality control are provided in factories, in plants, and on site;
- execution is carried out according to the relevant standards and specifications by personnel having the appropriate skill and experience;
- construction materials and products are used as specified in this standard or in the relevant material or product specifications;
- the structure will be adequately maintained to ensure its safety and serviceability for the designed service life;
- the structure will be used for the purpose defined for the design.

(3) These assumptions need to be considered both by the designer and the client. To prevent uncertainty, compliance with them should be documented, e.g. in the geotechnical design report.

1.4 Distinction between Principles and Application Rules

(1) Depending on the character of the individual clauses, distinction is made in EN 1997-1 between Principles and Application Rules.

(2) The Principles comprise:

- general statements and definitions for which there is no alternative;
- requirements and analytical models for which no alternative is permitted unless specifically stated.

(3) The Principles are preceded by the letter P.

(4) The Application Rules are examples of generally recognised rules, which follow the Principles and satisfy their requirements.

(5) It is permissible to use alternatives to the Application Rules given in this standard, provided it is shown that the alternative rules accord with the relevant Principles and are at least

equivalent with regard to the structural safety, serviceability and durability, which would be expected when using the Eurocodes.

NOTE If an alternative design rule is submitted for an application rule, the resulting design cannot be claimed to be wholly in accordance with EN 1997-1, although the design will remain in accordance with the Principles of EN 1997-1. When EN 1997-1 is used in respect of a property listed in an Annex Z of a product standard or an ETAG, the use of an alternative design rule may not be acceptable for CE marking.

(6) In EN 1997-1, the Application rules are identified by a number in brackets e.g. as in this clause.

1.5 Definitions

1.5.1 Definitions common to all Eurocodes

(1) The definitions common to all Eurocodes are given in EN 1990:2002, 1.5.

1.5.2 Definitions specific for EN 1997-1

1.5.2.1

geotechnical action

action transmitted to the structure by the ground, fill, standing water or ground-water

NOTE Definition taken from EN 1990:2002

1.5.2.2

comparable experience

documented or other clearly established information related to the ground being considered in design, involving the same types of soil and rock and for which similar geotechnical behaviour is expected, and involving similar structures. Information gained locally is considered to be particularly relevant

1.5.2.3

ground

soil, rock and fill in place prior to the execution of the construction works;

1.5.2.4

structure

organised combination of connected parts, including fill placed during execution of the construction works, designed to carry loads and provide adequate rigidity

NOTE Definition derived from EN 1990:2002

1.5.2.5

derived value

value of a geotechnical parameter obtained by theory, correlation or empiricism from test results

1.5.2.6

stiffness

material resistance against deformation

1.5.2.7

resistance

capacity of a component, or cross-section of a component of a structure to withstand actions without mechanical failure e.g. resistance of the ground, bending resistance, buckling resistance, tensile resistance

NOTE Definition derived from EN 1990:2002

1.6 Symbols

(1) For the purpose of EN 1997-1 the following symbols apply.

Latin letters

$\langle AC_1 \rangle A'$	effective base area ($A' = B' \times L'$) $\langle AC_1 \rangle$
A_b	base area under pile
A_c	total base area under compression
$A_{s,i}$	pile shaft surface area in layer i
a_d	design value of geometrical data
a_{nom}	nominal value of geometrical data
Δa	change made to nominal geometrical data for particular design purposes
$\langle AC_1 \rangle B \langle AC_1 \rangle$	width of a foundation.
b'	effective width of a foundation
C_d	limiting design value of the $\langle AC_1 \rangle$ relevant serviceability criterion $\langle AC_1 \rangle$
c	cohesion intercept
c'	cohesion intercept in terms of effective stress
c_u	undrained shear strength
$c_{u,d}$	design value of undrained shear strength
d	embedment depth;
E_d	design value of the effect of actions
$E_{stb;d}$	design value of the effect of stabilising actions
$E_{dst;d}$	design value of the effect of destabilising actions
$F_{c;d}$	design axial compression load on a pile or a group of piles
F_d	design value of an action
F_k	characteristic value of an action
F_{rep}	representative value of an action
$F_{t;d}$	design axial tensile load on a tensile pile or a group of tensile piles

$F_{tr,d}$	design value of the transverse load on a pile or a pile foundation
$G_{dst,d}$	design value of the destabilising permanent actions for uplift verification
$G_{stb,d}$	design value of the stabilising permanent vertical actions for uplift verification
$G'_{stb,d}$	design value of the stabilising permanent vertical actions for heave verification (submerged weight)
H	horizontal load, or component of total action acting parallel to the foundation base
H_d	design value of H
h	height of a wall
h	water level for hydraulic heave
h'	height of a soil prism for verifying hydraulic heave
$h_{w,k}$	characteristic value of the hydrostatic water head at the bottom of a soil prism
K_0	coefficient of earth pressure at rest
$K_{0,\beta}$	coefficient of earth pressure at rest for a retained earth surface inclined at angle β to the horizontal
k	ratio $\delta_d/\varphi_{cv,d}$
$\boxed{AC_1} L \langle \boxed{AC_1} \rangle$	foundation length;
l	effective foundation length
n	number of e.g. piles or test profiles
$\boxed{A_1} \text{ text deleted } \langle \boxed{A_1} \rangle$	
P_d	design value of P
$\boxed{A_1} \text{ text deleted } \langle \boxed{A_1} \rangle$	
$Q_{dst,d}$	design value of the destabilising variable vertical actions for uplift verification
$\boxed{AC_1} q_{b,k}$	characteristic value of unit base resistance $\langle \boxed{AC_1} \rangle$
$\boxed{AC_1} q_{s,i,k}$	characteristic value of unit shaft resistance in stratum i $\langle \boxed{AC_1} \rangle$
$\boxed{AC_1} q_u$	unconfined compressive strength $\langle \boxed{AC_1} \rangle$
$\boxed{A_1} \text{ text deleted } \langle \boxed{A_1} \rangle$	
$\boxed{A_1} \text{ text deleted } \langle \boxed{A_1} \rangle$	
$\boxed{A_1} \text{ text deleted } \langle \boxed{A_1} \rangle$	
$R_{b,cal}$	pile base resistance, calculated from ground test results, at the ultimate limit state

$R_{b;d}$	design value of the base resistance of a pile
$R_{b;k}$	characteristic value of the base resistance of a pile
R_c	compressive resistance of the ground against a pile, at the ultimate limit state
$R_{c;cal}$	calculated value of R_c
$R_{c;d}$	design value of R_c
$R_{c;k}$	characteristic value of R_c
$R_{c;m}$	measured value of R_c in one or several pile load tests
R_d	design value of the resistance to an action
$R_{p;d}$	design value of the resisting force caused by earth pressure on the side of a foundation
$R_{s;d}$	design value of the shaft resistance of a pile
$R_{s;cal}$	ultimate shaft friction, calculated using ground parameters from test results
$R_{s;k}$	characteristic value of the shaft resistance of a pile
R_t	ultimate tensile resistance of an isolated pile
$R_{t;d}$	design value of the tensile resistance of a pile or of a group of piles \square_{A1}
$R_{t;k}$	characteristic value of the tensile resistance of a pile or a pile group
$R_{t;m}$	measured tensile resistance of an isolated pile in one or several pile load tests
R_{tr}	resistance of a pile to transverse loads
$R_{tr;d}$	design resistance of transversally loaded pile
$S_{dst;d}$	design value of the destabilising seepage force in the ground
$S_{dst;k}$	characteristic value of the destabilising seepage force in the ground
s	settlement
s_0	immediate settlement
s_1	settlement caused by consolidation
s_2	settlement caused by creep (secondary settlement)
T_d	design value of total shearing resistance that develops around a block of ground in which a group of tension piles is placed, or on the part of the structure in contact with the ground
u	pore-water pressure

$u_{dst;d}$	design value of destabilising total pore-water pressure
V	vertical load, or component of the total action acting normal to the foundation base
V_d	design value of V
V'_d	design value of the effective vertical action or component of the total action acting normal to the foundation base
$V_{dst;d}$	design value of the destabilising vertical action on a structure
$V_{dst;k}$	characteristic value of the destabilising vertical action on a structure
X_d	design value of a material property
X_k	characteristic value of a material property
z	vertical distance

A1 Latin letters used in Section 8

$E_{ULS;d}$	ultimate limit state design force to be resisted by the anchor
$F_{Serv;d}$	design value of the maximum anchor force, including effect of lock off load, and sufficient to prevent a serviceability limit state in the supported structure
$F_{Serv;k}$	characteristic value of the maximum anchor force, including effect of lock off load, and sufficient to prevent a serviceability limit state in the supported structure
$F_{ULS;d}$	design value of the force required to prevent any ultimate limit state in the supported structure
$k_{i;SLS}$	permissible cumulative loss of load over specified time period, defined in EN ISO 22477-5, used to determine serviceability limit state resistance of an anchor
$k_{i;ULS}$	permissible cumulative loss of load over specified time period, defined in EN ISO 22477-5, used to determine ultimate limit state resistance of an anchor
n	minimum number of investigation and/or suitability tests
P_c	the critical creep load, determined as the load corresponding to the end of the pseudo linear part of the α versus load diagram as defined in EN ISO 22477-5
P_o	lock-off load, load left in the anchor head immediately on completion of the stressing operation
P_p	proof load, maximum test load to which an anchor is subjected in a particular load test
R_m	measured value of the resistance of an anchor
$R_{SLS;d}$	design value of the resistance of an anchor complying with serviceability limit state criteria
$R_{SLS;k}$	characteristic value of the resistance of an anchor complying with serviceability limit state criteria
$R_{SLS;m}$	measured value of the resistance of an anchor complying with serviceability limit state criteria
$(R_{SLS;m})_{min}$	lowest value of $R_{SLS;m}$ measured from a number of investigation or suitability tests (n), for each distinct ground condition
$R_{t;d}$	ultimate limit state design resistance of the structural elements of an anchor

- $R_{ULS;d}$ design value of the resistance of an anchor complying with ultimate limit state criteria
- $R_{ULS;k}$ characteristic value of the resistance of an anchor complying with ultimate limit state criteria
- $R_{ULS;m}$ measured value of the resistance of an anchor complying with ultimate limit state criteria
- $(R_{ULS;m})_{min}$ lowest value of $R_{ULS;m}$ measured from a number of investigation or suitability tests (n), for each distinct ground condition

(end text)

After “ φ'_d ” design value of φ' “, add:

(begin text)

Greek letters used in Section 8

α_{SLS} creep rate defining serviceability limit state resistance of an anchor, determined from the displacement per log cycle of time at constant anchor load as defined in EN ISO 22477-5

α_{ULS} creep rate defining ultimate limit state resistance of an anchor, determined from the displacement per log cycle of time at constant anchor load as defined in EN ISO 22477-5

$\gamma_{Serv}, \gamma_{a;ULS}, \gamma_{a;SLS}, \gamma_{a;acc;ULS}, \gamma_{a;acc;SLS}$ partial factors

ξ_{ULS} correlation factor $\langle A_1 \rangle$

Greek letters

- α inclination of a foundation base to the horizontal
- β slope angle of the ground behind a wall (upward positive)
- δ structure-ground interface friction angle
- δ_d design value of δ
- γ weight density

$\langle A_1 \rangle$ text deleted $\langle A_1 \rangle$

$\langle A_1 \rangle$ text deleted $\langle A_1 \rangle$

$\langle A_1 \rangle$ text deleted $\langle A_1 \rangle$

- $\gamma_{a;t}$ partial factor for temporary anchorages
- γ_b partial factor for the base resistance of a pile
- γ_c partial factor for the effective cohesion
- γ_{cu} partial factor for the undrained shear strength
- γ_E partial factor for the effect of an action

γ	partial factor for actions, which takes account of the possibility of unfavourable deviations of the action values from the representative values
γ_F	partial factor for an action
γ_G	partial factor for a permanent action
$\gamma_{G,dst}$	partial factor for a permanent destabilising action
$\gamma_{G,stb}$	partial factor for a permanent stabilising action
γ_m	partial factor for a soil parameter (material property)
$\gamma_{m,i}$	partial factor for a soil parameter in stratum i
γ_M	partial factor for a soil parameter (material property), also accounting for model uncertainties
γ_Q	partial factor for a variable action
γ_{qu}	partial factor for unconfined strength
γ_R	partial factor for a resistance
$\gamma_{R;d}$	partial factor for uncertainty in a resistance model
$\gamma_{R,e}$	partial factor for passive earth resistance $\langle AC_1 \rangle$
$\gamma_{R,h}$	partial factor for sliding resistance
$\gamma_{R,v}$	partial factor for bearing resistance
γ_s	partial factor for shaft resistance of a pile
$\gamma_{S;d}$	partial factor for uncertainties in modelling the effects of actions
$\gamma_{Q,dst}$	partial factor for a variable destabilising action $\langle AC_1 \rangle$
$\gamma_{Q,stb}$	partial factor for a variable stabilising action $\langle AC_1 \rangle$
$\gamma_{s,t}$	partial factor for tensile resistance of a pile
γ	partial factor for total resistance of a pile
γ_w	weight density of water
γ_ϕ	partial factor for the angle of shearing resistance ($\tan \phi$)
γ_γ	partial factor for weight density
θ	direction angle of H
ξ	correlation factor depending on the number of piles tested or of profiles of tests

\square_{A1} text deleted \square_{A1}

- $\xi_1; \xi_2$ correlation factors to evaluate the results of static pile load tests
- $\xi_3; \xi_4$ correlation factors to derive the pile resistance from ground investigation results, not being pile load tests.
- $\xi_5; \xi_6$ correlation factors to derive the pile resistance from dynamic impact tests
- ψ factor for converting the characteristic value to the representative value
- $\sigma_{\text{stb;d}}$ design value of stabilising total vertical stress
- $\sigma'_{h;0}$ horizontal component of effective earth pressure at rest
- $\sigma(z)$ stress normal to a wall at depth z
- $\tau(z)$ stress tangential to a wall at depth z
- ϕ angle of shearing resistance in terms of effective stress
- ϕ_{cv} critical state angle of shearing resistance
- $\phi_{\text{cv;d}}$ design value of ϕ_{cv}
- ϕ'_d design value of ϕ

Abbreviations

- CFA Continuous flight auger piles
- OCR over-consolidation ratio

NOTE 1 The symbols commonly used in all Eurocodes are defined in EN 1990:2002

NOTE 2 The notation of the symbols used is based on ISO 3898:1997.

(2) For geotechnical calculations, the following units or their multiples are recommended:

- | | |
|--|-------------------|
| — force | kN |
| — mass | kg |
| — moment | kNm |
| — mass density | kg/m ³ |
| — weight density | kN/m ³ |
| — stress, pressure, strength and stiffness | kPa |
| — coefficient of permeability | m/s |
| — coefficient of consolidation | m ² /s |

Section 2 Basis of geotechnical design

2.1 Design requirements

(1)P For each geotechnical design situation it shall be verified that no relevant limit state, as defined in EN 1990:2002, is exceeded.

(2) When defining the design situations and the limit states, the following factors should be considered:

- site conditions with respect to overall stability and ground movements;
- nature and size of the structure and its elements, including any special requirements such as the design life;
- conditions with regard to its surroundings (e.g.: neighbouring structures, traffic, utilities, vegetation, hazardous chemicals);
- ground conditions;
- ground-water conditions;
- regional seismicity;
- influence of the environment (hydrology, surface water, subsidence, seasonal changes of temperature and moisture).

(3) Limit states can occur either in the ground or in the structure or by combined failure in the structure and the ground.

(4) Limit states should be verified by one or a combination of the following:

- use of calculations as described in 2.4;
- adoption of prescriptive measures, as described in 2.5;
- experimental models and load tests, as described in 2.6;
- an observational method, as described in 2.7.

(5) In practice, experience will often show which type of limit state will govern the design and the avoidance of other limit states may be verified by a control check.

(6) Buildings should normally be protected against the penetration of ground-water or the transmission of vapour or gases to their interiors.

(7) If practicable, the design results should be checked against comparable experience.

(8)P In order to establish minimum requirements for the extent and content of geotechnical investigations, calculations and construction control checks, the complexity of each geotechnical design shall be identified together with the associated risks. In particular, a distinction shall be made between:

- light and simple structures and small earthworks for which it is possible to ensure that the minimum requirements will be satisfied by experience and qualitative geotechnical investigations, with negligible risk;
- other geotechnical structures.

NOTE The manner in which these minimum requirements are satisfied may be given in the National annex.

(9) For structures and earthworks of low geotechnical complexity and risk, such as defined above, simplified design procedures may be applied.

(10) To establish geotechnical design requirements, three Geotechnical Categories, 1, 2 and 3, may be introduced.

(11) A preliminary classification of a structure according to Geotechnical Category should normally be performed prior to the geotechnical investigations. The category should be checked and changed, if necessary, at each stage of the design and construction process.

(12) The procedures of higher categories may be used to justify more economic designs, or if the designer considers them to be appropriate.

(13) The various design aspects of a project can require treatment in different Geotechnical Categories. It is not required to treat the whole of the project according to the highest of these categories.

(14) Geotechnical Category 1 should only include small and relatively simple structures:

- for which it is possible to ensure that the fundamental requirements will be satisfied on the basis of experience and qualitative geotechnical investigations;
- with negligible risk.

(15) Geotechnical Category 1 procedures should be used only where there is negligible risk in terms of overall stability or ground movements and in ground conditions, which are known from comparable local experience to be sufficiently straightforward. In these cases the procedures may consist of routine methods for foundation design and construction.

(16) Geotechnical Category 1 procedures should be used only if there is no excavation below the water table or if comparable local experience indicates that a proposed excavation below the water table will be straightforward.

(17) Geotechnical Category 2 should include conventional types of structure and foundation with no exceptional risk or difficult AC_1 ground AC_1 or loading conditions

(18) Designs for structures in Geotechnical Category 2 should normally include quantitative geotechnical data and analysis to ensure that the fundamental requirements are satisfied.

(19) Routine procedures for field and laboratory testing and for design and execution may be used for Geotechnical Category 2 designs.

NOTE The following are examples of conventional structures or parts of structures complying with Geotechnical Category 2:

- spread foundations;
- raft foundations;
- pile foundations;
- walls and other structures retaining or supporting soil or water;
- excavations;
- bridge piers and abutments;

- embankments and earthworks;
- ground anchors and other tie-back systems;
- tunnels in hard, non-fractured rock and not subjected to special water tightness or other requirements.

(20) Geotechnical Category 3 should include structures or parts of structures, which fall outside the limits of Geotechnical Categories 1 and 2.

(21) Geotechnical Category 3 should normally include alternative provisions and rules to those in this standard.

NOTE Geotechnical Category 3 includes the following examples:

- very large or unusual structures;
- structures involving abnormal risks, or unusual or exceptionally difficult ground or loading conditions;
- structures in highly seismic areas;
- structures in areas of probable site instability or persistent ground movements that require separate investigation or special measures.

2.2 Design situations

(1)P Both short-term and long-term design situations shall be considered.

(2) In geotechnical design, the detailed specifications of design situations should include, as appropriate:

- the actions, their combinations and load cases;
- the general suitability of the ground on which the structure is located with respect to overall stability and ground movements;
- the disposition and classification of the various zones of soil, rock and elements of construction, which are involved in any calculation model;
- dipping bedding planes;
- mine workings, caves or other underground structures;
- in the case of structures resting on or near rock:
 - interbedded hard and soft strata;
 - faults, joints and fissures;
 - possible instability of rock blocks;
 - solution cavities, such as swallow holes or fissures filled with soft material, and continuing solution processes;
- the environment within which the design is set, including the following:
 - effects of scour, erosion and excavation, leading to changes in the geometry of the ground surface;
 - effects of chemical corrosion;

- effects of weathering;
- effects of freezing;
- effects of long duration droughts;
- variations in ground-water levels, including, e.g. the effects of dewatering, possible flooding, failure of drainage systems, water exploitation;
- the presence of gases emerging from the ground;
- other effects of time and environment on the strength and other properties of materials; e.g. the effect of holes created by animal activities;
- earthquakes;
- ground movements caused by subsidence due to mining or other activities;
- the sensitivity of the structure to deformations;
- the effect of the new structure on existing structures, services and the local environment.

2.3 Durability

(1)P At the geotechnical design stage, the significance of environmental conditions shall be assessed in relation to durability and to enable provisions to be made for the protection or adequate resistance of the materials.

(2) In designing for durability of materials used in the ground, the following should be considered:

a) for concrete:

- aggressive agents in the ground-water or in the ground or fill material, such as acids or sulfate salts;

b) for steel:

- chemical attack where foundation elements are buried in ground that is sufficiently permeable to allow the percolation of ground-water and oxygen;
- corrosion on the faces of sheet pile walls exposed to free water, particularly in the mean water level zone;
- the pitting type of corrosive attack on steel embedded in fissured or porous concrete, particularly for rolled steel where the mill scale, acting as a cathode, promotes electrolytic action with the scale-free surface acting as an anode;

c) for timber:

- fungi and aerobic bacteria in the presence of oxygen;

d) for synthetic fabrics:

- the ageing effects of UV exposure or ozone degradation or the combined effects of temperature and stress, and secondary effects due to chemical degradation.

(3) Reference should be made to durability provisions in construction materials standards.

2.4 Geotechnical design by calculation

2.4.1 General

(1)P Design by calculation shall be in accordance with the fundamental requirements of EN 1990:2002 and with the particular rules of this standard. Design by calculation involves:

- actions, which may be either imposed loads or imposed displacements, e.g. from ground movements;
- properties of soils, rocks and other materials;
- geometrical data;
- limiting values of deformations, crack widths, vibrations etc.;
- calculation models.

(2) It should be considered that knowledge of the ground conditions depends on the extent and quality of the geotechnical investigations. Such knowledge and the control of workmanship are usually more significant to fulfilling the fundamental requirements than is precision in the calculation models and partial factors.

(3)P The calculation model shall describe the assumed behaviour of the ground for the limit state under consideration.

(4)P If no reliable calculation model is available for a specific limit state, analysis of another limit state shall be carried out using factors to ensure that exceeding the specific limit state considered is sufficiently improbable. Alternatively, design by prescriptive measures, experimental models and load tests, or the observational method, shall be performed.

(5) The calculation model may consist of any of the following:

- an analytical model;
- a semi-empirical model;
- a numerical model.

(6)P Any calculation model shall be either accurate or err on the side of safety.

(7) A calculation model may include simplifications.

(8) If needed, a modification of the results from the model may be used to ensure that the design calculation is either accurate or errs on the side of safety.

(9) If the modification of the results makes use of a model factor, it should take account of the following:

- the range of uncertainty in the results of the method of analysis;
- any systematic errors known to be associated with the method of analysis.

(10)P If an empirical relationship is used in the analysis, it shall be clearly established that it is relevant for the prevailing ground conditions.

(11) Limit states involving the formation of a mechanism in the ground should be readily checked using a calculation model. For limit states defined by deformation considerations, the deformations should be evaluated by calculation as described in 2.4.8, or otherwise assessed.

NOTE Many calculation models are based on the assumption of a sufficiently ductile performance of the ground/structure system. A lack of ductility, however, will lead to an ultimate limit state characterised by sudden collapse.

(12) Numerical methods can be appropriate if compatibility of strains or the interaction between the structure and the soil at a limit state are considered.

(13) Compatibility of strains at a limit state should be considered. Detailed analysis, allowing for the relative stiffness of structure and ground, may be needed in cases where a combined failure of structural members and the ground could occur. Examples include raft foundations, laterally loaded piles and flexible retaining walls. Particular attention should be paid to strain compatibility for materials that are brittle or that have strain-softening properties.

(14) In some problems, such as excavations supported by anchored or strutted flexible walls, the magnitude and distribution of earth pressures, internal structural forces and bending moments depend to a great extent on the stiffness of the structure, the stiffness and strength of the ground and the state of stress in the ground.

(15) In these problems of ground-structure interaction, analyses should use stress-strain relationships for ground and structural materials and stress states in the ground that are sufficiently representative, for the limit state considered, to give a safe result.

2.4.2 Actions

(1)P The definition of actions shall be taken from EN 1990:2002. The values of actions shall be taken from EN 1991, where relevant.

(2)P The values of geotechnical actions to be used shall be selected, since they are known before a calculation is performed; they may change during that calculation.

NOTE Values of geotechnical actions may change during the course of calculation. In such cases they will be introduced as a first estimate to start the calculation with a preliminary, known value.

(3)P Any interaction between the structure and the ground shall be taken into account when determining the actions to be adopted in the design.

(4) In geotechnical design, the following should be considered for inclusion as actions:

- the weight of soil, rock and water;
- stresses in the ground;
- earth pressures $\boxed{AC_1}$ *text deleted* $\boxed{AC_1}$;
- free water pressures, including wave pressures;
- ground-water pressures;
- seepage forces;
- dead and imposed loads from structures;
- surcharges;
- mooring forces;
- removal of load or excavation of ground;
- traffic loads;

- movements caused by mining or other caving or tunnelling activities;
- swelling and shrinkage caused by vegetation, climate or moisture changes;
- movements due to creeping or sliding or settling ground masses;
- movements due to degradation, dispersion, decomposition, self-compaction and solution;
- movements and accelerations caused by earthquakes, explosions, vibrations and dynamic loads;
- temperature effects, including frost action;
- ice loading;
- imposed pre-stress in ground anchors or struts;
- downdrag.

(5)P Consideration shall be given to the possibility of variable actions occurring both jointly and separately.

(6)P The duration of actions shall be considered with reference to time effects in the material properties of the soil, especially the drainage properties and compressibility of fine-grained soils.

(7)P Actions, which are applied repeatedly, and actions with variable intensity shall be identified for special consideration with regard to, e.g. continuing movements, liquefaction of soils, change of ground stiffness and strength.

(8)P Actions that produce a dynamic response in the structure and the ground shall be identified for special consideration.

(9)P Actions in which ground- and free-water forces predominate shall be identified for special consideration with regard to deformations, fissuring, variable permeability and erosion.

NOTE Unfavourable (or destabilising) and favourable (or stabilising) permanent actions may in some situations be considered as coming from a single source. If they are considered so, a single partial factor may be applied to the sum of these actions or to the sum of their effects.

2.4.3 Ground properties

(1)P Properties of soil and rock masses, as quantified for design calculations by geotechnical parameters, shall be obtained from test results, either directly or through correlation, theory or empiricism, and from other relevant data.

(2)P Values obtained from test results and other data shall be interpreted appropriately for the limit state considered.

(3)P Account shall be taken of the possible differences between the ground properties and geotechnical parameters obtained from test results and those governing the behaviour of the geotechnical structure.

(4) The differences to which 2.4.3(3)P refers can be due to the following factors:

- many geotechnical parameters are not true constants but depend on stress level and mode of deformation;

- soil and rock structure (e.g. fissures, laminations, or large particles) that may play a different role in the test and in the geotechnical structure;
- time effects;
- the softening effect of percolating water on soil or rock strength;
- the softening effect of dynamic actions;
- the brittleness or ductility of the soil and rock tested;
- the method of installation of the geotechnical structure;
- the influence of workmanship on artificially placed or improved ground;
- the effect of construction activities on the properties of the ground.

(5) When establishing values of geotechnical parameters, the following should be considered:

- published and well recognised information relevant to the use of each type of test in the appropriate ground conditions;
- the value of each geotechnical parameter compared with relevant published data and local and general experience;
- the variation of the geotechnical parameters that are relevant to the design;
- the results of any large scale field trials and measurements from neighbouring constructions;
- any correlations between the results from more than one type of test;
- any significant deterioration in ground material properties that may occur during the lifetime of the structure.

(6)P Calibration factors shall be applied where necessary to convert laboratory or field test results according to EN 1997-2 into values that represent the behaviour of the soil and rock in the ground, for the actual limit state, or to take account of correlations used to obtain derived values from the test results.

2.4.4 Geometrical data

(1)P The level and slope of the ground surface, water levels, levels of interfaces between strata, excavation levels and the dimensions of the geotechnical structure shall be treated as geometrical data.

2.4.5 Characteristic values

2.4.5.1 Characteristic and representative values of actions

(1)P Characteristic and representative values of actions shall be derived in accordance with EN 1990:2002 and the various parts of EN 1991.

2.4.5.2 Characteristic values of geotechnical parameters

(1)P The selection of characteristic values for geotechnical parameters shall be based on results and derived values from laboratory and field tests, complemented by well-established experience.

(2)P The characteristic value of a geotechnical parameter shall be selected as a cautious estimate of the value affecting the occurrence of the limit state.

(3)P The greater variance of c' compared to that of $\tan\phi'$ shall be considered when their characteristic values are determined.

(4)P The selection of characteristic values for geotechnical parameters shall take account of the following:

- geological and other background information, such as data from previous projects;
- the variability of the measured property values and other relevant information, e.g. from existing knowledge;
- the extent of the field and laboratory investigation;
- the type and number of samples;
- the extent of the zone of ground governing the behaviour of the geotechnical structure at the limit state being considered;
- the ability of the geotechnical structure to transfer loads from weak to strong zones in the ground.

(5) Characteristic values can be lower values, which are less than the most probable values, or upper values, which are greater.

(6)P For each calculation, the most unfavourable combination of lower and upper values of independent parameters shall be used.

(7) The zone of ground governing the behaviour of a geotechnical structure at a limit state is usually much larger than a test sample or the zone of ground affected in an in situ test. Consequently the value of the governing parameter is often the mean of a range of values covering a large surface or volume of the ground. The characteristic value should be a cautious estimate of this mean value.

(8) If the behaviour of the geotechnical structure at the limit state considered is governed by the lowest or highest value of the ground property, the characteristic value should be a cautious estimate of the lowest or highest value occurring in the zone governing the behaviour.

(9) When selecting the zone of ground governing the behaviour of a geotechnical structure at a limit state, it should be considered that this limit state may depend on the behaviour of the supported structure. For instance, when considering a bearing resistance ultimate limit state for a building resting on several footings, the governing parameter should be the mean strength over each individual zone of ground under a footing, if the building is unable to resist a local failure. If, however, the building is stiff and strong enough, the governing parameter should be the mean of these mean values over the entire zone or part of the zone of ground under the building.

(10) If statistical methods are employed in the selection of characteristic values for ground properties, such methods should differentiate between local and regional sampling and should allow the use of a priori knowledge of comparable ground properties.

(11) If statistical methods are used, the characteristic value should be derived such that the calculated probability of a worse value governing the occurrence of the limit state under consideration is not greater than 5%.

NOTE In this respect, a cautious estimate of the mean value is a selection of the mean value of the limited set of geotechnical parameter values, with a confidence level of 95%; where local failure is concerned, a cautious estimate of the low value is a 5% fractile.

(12)P When using standard tables of characteristic values related to soil investigation parameters, the characteristic value shall be selected as a very cautious value.

2.4.5.3 Characteristic values of geometrical data

(1)P Characteristic values of the levels of ground and ground-water or free water shall be measured, nominal or estimated upper or lower levels.

(2) Characteristic values of levels of ground and dimensions of geotechnical structures or elements should usually be nominal values.

2.4.6 Design values

2.4.6.1 Design values of actions

(1)P The design value of an action shall be determined in accordance with EN 1990:2002.

(2)P The design value of an action (F_d) shall either be assessed directly or shall be derived from representative values using the following equation:

$$F_d = \gamma_f \cdot F_{rep} \quad (2.1a)$$

with

$$F_{rep} = \psi \cdot F_k \quad (2.1b)$$

(3)P Appropriate values of ψ shall be taken from EN 1990:2002.

(4)P The partial factor γ_f for persistent and transient situations defined in Annex A shall be used in equation (2.1a).

NOTE 1 The values of the partial factors may be set by the National annex.

NOTE 2 The recommended values in Annex A indicate the appropriate level of safety for conventional designs.

(5) If design values of geotechnical actions are assessed directly, the values of the partial factors recommended in Annex A should be used as a guide to the required level of safety.

(6)P When dealing with ground-water pressures for limit states with severe consequences (generally ultimate limit states), design values shall represent the most unfavourable values that could occur during the design lifetime of the structure. For limit states with less severe consequences (generally serviceability limit states), design values shall be the most unfavourable values which could occur in normal circumstances.

(7) In some cases extreme water pressures complying with 1.5.3.5 of EN 1990:2002, may be treated as accidental actions.

(8) Design values of ground-water pressures may be derived either by applying partial factors to characteristic water pressures or by applying a safety margin to the characteristic water level in accordance with 2.4.4(1)P and 2.4.5.3(1)P.

(9) The following features, which may affect the water pressures should be considered:

- the level of the free water surface or the ground-water table;
- the favourable or unfavourable effects of drainage, both natural and artificial, taking account of its future maintenance;
- the supply of water by rain, flood, burst water mains or other means;
- changes of water pressures due to the growth or removal of vegetation.

(10) Consideration should be given to unfavourable water levels that may be caused by changes in the water catchment and reduced drainage due to blockage, freezing or other causes.

(11) Unless the adequacy of the drainage system can be demonstrated and its maintenance ensured, the design ground-water table should be taken as the maximum possible level, which may be the ground surface.

2.4.6.2 Design values of geotechnical parameters

(1)P Design values of geotechnical parameters (X_d) shall either be derived from characteristic values using the following equation:

$$X_d = X_k / \gamma_M \quad (2.2)$$

or shall be assessed directly.

(2)P The partial factor γ_M for persistent and transient situations defined in Annex A shall be used in equation (2.2).

NOTE 1 The values of the partial factors may be set by the National annex.

NOTE 2 The recommended values in Annex A indicate the minimum level of safety for conventional designs.

(3) If design values of geotechnical parameters are assessed directly, the values of the partial factors recommended in Annex A should be used as a guide to the required level of safety.

2.4.6.3 Design values of geometrical data

(1) The partial action and material factors (γ_F and γ_M) include an allowance for minor variations in geometrical data and, in such cases, no further safety margin on the geometrical data should be required.

(2)P In cases where deviations in the geometrical data have a significant effect on the reliability of a structure, design values of geometrical data (a_d) shall either be assessed directly or be derived from nominal values using the following equation (see 6.3.4 of EN 1990:2002):

$$a_d = a_{nom} \pm \Delta a \quad (2.3)$$

for which values of Δa are given in 6.5.4(2) and 9.3.2.2

2.4.6.4 Design values of structural properties

(1)P The design strength properties of structural materials and the design resistances of structural elements shall be calculated in accordance with EN 1992 to EN 1996 and EN 1999.

2.4.7 Ultimate Limit States

2.4.7.1 General

(1)P Where relevant, it shall be verified that the following limit states are not exceeded:

- loss of equilibrium of the structure or the ground, considered as a rigid body, in which the strengths of structural materials and the ground are insignificant in providing resistance (EQU);
- internal failure or excessive deformation of the structure or structural elements, including e.g. footings, piles or basement walls, in which the strength of structural materials is significant in providing resistance (STR);
- failure or excessive deformation of the ground, in which the strength of soil or rock is significant in providing resistance (GEO);
- loss of equilibrium of the structure or the ground due to uplift by water pressure (buoyancy) or other vertical actions (UPL);
- hydraulic heave, internal erosion and piping in the ground caused by hydraulic gradients (HYD).

NOTE Limit state GEO is often critical to the sizing of structural elements involved in foundations or retaining structures and sometimes to the strength of structural elements.

(2)P The partial factors in persistent and transient situations defined in Annex A shall be used.

NOTE The values of the partial factors may be set by the National annex. The tables in Annex A give the recommended values.

(3) All values of partial factors for actions or the effects of actions in accidental situations should normally be taken equal to 1,0. All values of partial factors for resistances should then be selected according to the particular circumstances of the accidental situation.

NOTE The values of the partial factors may be set by the National annex.

(4) More severe values than those recommended in Annex A should be used in cases of abnormal risk or unusual or exceptionally difficult ground or loading conditions.

AC1 NOTE The values of partial factors may be set by the National Annex. **AC1**

(5) Less severe values than those recommended in Annex A may be used for temporary structures or transient design situations, where the likely consequences justify it.

AC1 NOTE The values of partial factors may be set by the National Annex. **AC1**

(6) When calculating the design value of the resistance, (R_d), or the design value of the effect of actions, (E_d), model factors, ($\gamma_{R;d}$) or ($\gamma_{S;d}$) respectively, may be introduced to ensure that the results of the design calculation model are either accurate or err on the safe side.

AC1 NOTE The values of model factors may be set by the National Annex. **AC1**

2.4.7.2 Verification of static equilibrium

(1)P When considering a limit state of static equilibrium or of overall displacements of the structure or ground (EQU), it shall be verified that:

$$E_{dst;d} \leq E_{stb;d} + T_d \quad (2.4)$$

with

$$E_{dst;d} = E\{\gamma_F F_{rep}; X_k / \gamma_M; a_d\}_{dst} \quad (2.4a)$$

and

$$E_{stb;d} = E\{\gamma_F F_{rep}; X_k / \gamma_M; a_d\}_{stb} \quad (2.4b)$$

(2)P The partial factors for persistent and transient situations defined in A.2(1)P and A.2(2)P shall be used in equation (2.4).

NOTE 1 Static equilibrium EQU is mainly relevant in structural design. In geotechnical design, EQU verification will be limited to rare cases, such as a rigid foundation bearing on rock, and is, in principle, distinct from overall stability or buoyancy problems. If any shearing resistance T_d is included, it should be of minor importance.

NOTE 2 The values of the partial factors may be set by the National annex. Tables A.1 and A.2 give the recommended values.

2.4.7.3 Verification of resistance for structural and ground limit states in persistent and transient situations

2.4.7.3.1 General

(1)P When considering a limit state of rupture or excessive deformation of a structural element or section of the ground (STR and GEO), it shall be verified that:

$$E_d \leq R_d \quad (2.5)$$

2.4.7.3.2 Design effects of actions

(1) Partial factors on actions may be applied either to the actions themselves (F_{rep}) or to their effects (E):

$$E_d = E\{\gamma_F F_{rep}; X_k / \gamma_M; a_d\} \quad (2.6a)$$

or

$$E_d = \gamma_E E\{F_{rep}; X_k / \gamma_M; a_d\}. \quad (2.6b)$$

(2) In some design situations, the application of partial factors to actions coming from or through the soil (such as earth or water pressures) could lead to design values, which are unreasonable or even physically impossible. In these situations, the factors may be applied directly to the effects of actions derived from representative values of the actions.

(3)P The partial factors defined in A.3.1(1)P and A.3.2(1)P shall be used in equations (2.6a) and (2.6b).

NOTE The values of the partial factors may be set by the National annex. Tables A.3 and A.4 give the recommended values.

2.4.7.3.3 Design resistances

(1) Partial factors may be applied either to ground properties (X) or resistances (R) or to both, as follows:

$$R_d = R\{\gamma_F F_{rep}; X_k/\gamma_M; a_d\} \quad (2.7a)$$

or

$$R_d = R\{\gamma_F F_{rep}; X_k; a_d\}/\gamma_R \quad (2.7b)$$

or

$$R_d = R\{\gamma_F F_{rep}; X_k/\gamma_M; a_d\}/\gamma_R \quad (2.7c)$$

NOTE In design procedures where the effects of actions are factored, the partial factor for actions $\gamma_F = 1.0$. (see also B.3(6))

(2)P The partial factors, defined in A.3.3.1(1)P, A.3.3.2(1)P, A.3.3.4(1)P, A.3.3.5(1)P and A.3.3.6(1)P shall be used in equations (2.7a, b, and c).

NOTE The values of the partial factors may be set by the National annex. Tables A.5, A.6, A.7, A.8, A.12, A.13 and A.14 give the recommended values.

2.4.7.3.4 Design Approaches

2.4.7.3.4.1 General

(1)P The manner in which equations (2.6) and (2.7) are applied shall be determined using one of three Design Approaches.

NOTE 1 The way to use equations (2.6) and (2.7) and the particular Design Approach to be used may be given in the National annex.

NOTE 2 Further clarification of the Design Approaches is provided in Annex B.

NOTE 3 The partial factors in Annex A to be used in equations (2.6) and (2.7) are grouped in sets denoted by A (for actions or effects of actions), M (for soil parameters) and R (for resistances). They are selected according to the Design Approach used.

2.4.7.3.4.2 Design Approach 1

(1)P Except for the design of axially loaded piles and anchors, it shall be verified that a limit state of rupture or excessive deformation will not occur with either of the following combinations of sets of partial factors:

Combination 1: $A1$ "+" $M1$ "+" $R1$

Combination 2: $A2$ "+" $M2$ "+" $R1$

where "+" implies: "to be combined with".

NOTE In Combinations 1 and 2, partial factors are applied to actions and to ground strength parameters.

(2)P For the design of axially loaded piles and anchors, it shall be verified that a limit state of rupture or excessive deformation will not occur with either of the following combinations of sets of partial factors:

Combination 1: $A1$ "+" $M1$ "+" $R1$

Combination 2: $A2$ "+" ($M1$ or $M2$) "+" $R4$

NOTE 1 In Combination 1, partial factors are applied to actions and to ground strength parameters. In Combination 2, partial factors are applied to actions, to ground resistances and sometimes to ground strength parameters.

NOTE 2 In Combination 2, set $M1$ is used for calculating resistances of piles or anchors and set $M2$ for calculating unfavourable actions on piles owing e.g. to negative skin friction or transverse loading.

(3) If it is obvious that one of the two combinations governs the design, calculations for the other combination need not be carried out. However, different combinations may be critical to different aspects of the same design.

2.4.7.3.4.3 Design Approach 2

(1)P It shall be verified that a limit state of rupture or excessive deformation will not occur with the following combination of sets of partial factors:

Combination: $A1$ "+" $M1$ "+" $R2$

NOTE 1 In this approach, partial factors are applied to actions or to the effects of actions and to ground resistances.

NOTE 2 If this approach is used for slope and overall stability analyses the resulting effect of the actions on the failure surface is multiplied by γ_E and the shear resistance along the failure surface is divided by $\gamma_{R,e}$.

2.4.7.3.4.4 Design Approach 3

(1)P It shall be verified that a limit state of rupture or excessive deformation will not occur with the following combination of sets of partial factors:

Combination: ($A1^*$ or $A2^\dagger$) "+" $M2$ "+" $R3$

*on structural actions

†on geotechnical actions

NOTE 1 In this approach, partial factors are applied to actions or to the effects of actions from the structure and to ground strength parameters.

NOTE 2 For slope and overall stability analyses, actions on the soil (e.g. structural actions, traffic load) are treated as geotechnical actions by using the set of load factors $A2$.

2.4.7.4 Verification procedure and partial factors for uplift

(1)P Verification for uplift (UPL) shall be carried out by checking that the design value of the combination of destabilising permanent and variable vertical actions ($V_{dst;d}$) is less than or equal to the sum of the design value of the stabilising permanent vertical actions ($G_{stb;d}$) and of the design value of any additional resistance to uplift (R_d):

$$V_{dst;d} \leq G_{stb;d} + R_d \quad (2.8)$$

where

$$V_{dst;d} = G_{dst;d} + Q_{dst;d}$$

(2) Additional resistance to uplift may also be treated as a stabilising permanent vertical action ($G_{stb;d}$).

(3)P The partial factors for $G_{dst;d}$, $Q_{dst;d}$, $G_{stb;d}$ and R_d for persistent and transient situations defined in A.4(1)P and A.4(2)P shall be used in equation (2.8).

NOTE The values of the partial factors may be set by the National annex. Tables A.15 and A.16 give the recommended values.

2.4.7.5 Verification of resistance to failure by heave due to seepage of water in the ground

(1)P When considering a limit state of failure due to heave by seepage of water in the ground (HYD, see 10.3), it shall be verified, for every relevant soil column, that the design value of the destabilising total pore water pressure ($u_{dst;d}$) at the bottom of the column, or the design value of the seepage force ($S_{dst;d}$) in the column is less than or equal to the stabilising total vertical stress ($\sigma_{stb;d}$) at the bottom of the column, or the submerged weight ($G'_{stb;d}$) of the same column:

$$u_{dst;d} \leq \sigma_{stb;d} \quad (2.9a)$$

$$S_{dst;d} \leq G'_{stb;d} \quad (2.9b)$$

(2)P The partial factors for $u_{dst;d}$, $\sigma_{stb;d}$, $S_{dst;d}$ and $G'_{stb;d}$ for persistent and transient situations defined in A.5(1)P shall be used in equations 2.9a and 2.9b.

NOTE The values of the partial factors may be set by the National annex. Table A.17 gives the recommended values.

2.4.8 Serviceability limit states

(1)P Verification for serviceability limit states in the ground or in a structural section, element or connection, shall either require that:

$$E_d \leq C_d, \quad (2.10)$$

or be done through the method given in 2.4.8(4).

(2) Values of partial factors for serviceability limit states should normally be taken equal to 1,0.

NOTE The values of the partial factors may be set by the National annex.

(3) Characteristic values should be changed appropriately if changes of ground properties e.g. by ground-water lowering or desiccation, may occur during the life of the structure.

(4) It may be verified that a sufficiently low fraction of the ground strength is mobilised to keep deformations within the required serviceability limits, provided this simplified approach is restricted to design situations where:

- a value of the deformation is not required to check the serviceability limit state;
- established comparable experience exists with similar ground, structures and application method.

(5)P A limiting value for a particular deformation is the value at which a serviceability limit state, such as unacceptable cracking or jamming of doors, is deemed to occur in the supported structure. This limiting value shall be agreed during the design of the supported structure.

2.4.9 Limiting values for movements of foundations

(1)P In foundation design, limiting values shall be established for the foundation movements.

NOTE Permitted foundation movements may be set by the National annex.

(2)P Any differential movements of foundations leading to deformation in the supported structure shall be limited to ensure that they do not lead to a limit state in the supported structure.

(3)P The selection of design values for limiting movements and deformations shall take account of the following:

- the confidence with which the acceptable value of the movement can be specified;
- the occurrence and rate of ground movements;
- the type of structure;
- the type of construction material;
- the type of foundation;
- the type of ground;
- the mode of deformation;
- the proposed use of the structure;
- the need to ensure that there are no problems with the services entering the structure.

(4)P Calculations of differential settlement shall take account of:

- the occurrence and rate of settlements and ground movements;
- random and systematic variations in ground properties;
- the loading distribution;
- the construction method (including the sequence of loading);
- the stiffness of the structure during and after construction.

NOTE In the absence of specified limiting values of structural deformations of the supported structure, the values of structural deformation and foundation movement given in Annex H may be used.

2.5 Design by prescriptive measures

(1) In design situations where calculation models are not available or not necessary, exceeding limit states may be avoided by the use of prescriptive measures. These involve conventional and generally conservative rules in the design, and attention to specification and control of materials, workmanship, protection and maintenance procedures.

NOTE Reference to such conventional and generally conservative rules may be given in the National annex.

(2) Design by prescriptive measures may be used where comparable experience, as defined in 1.5.2.2, makes design calculations unnecessary. It may also be used to ensure durability

against frost action and chemical or biological attack, for which direct calculations are not generally appropriate.

2.6 Load tests and tests on experimental models

(1)P When the results of load tests or tests on large or small scale models are used to justify a design, or in order to complement one of the other alternatives mentioned in 2.1(4), the following features shall be considered and allowed for:

- differences in the ground conditions between the test and the actual construction;
- time effects, especially if the duration of the test is much less than the duration of loading of the actual construction;
- scale effects, especially if small models are used. The effects of stress levels shall be considered, together with the effects of particle size.

(2) Tests may be carried out on a sample of the actual construction or on full scale or smaller scale models.

2.7 Observational method

(1) When prediction of geotechnical behaviour is difficult, it can be appropriate to apply the approach known as "the observational method", in which the design is reviewed during construction.

(2)P The following requirements shall be met before construction is started:

- acceptable limits of behaviour shall be established;
- the range of possible behaviour shall be assessed and it shall be shown that there is an acceptable probability that the actual behaviour will be within the acceptable limits;
- a plan of monitoring shall be devised, which will reveal whether the actual behaviour lies within the acceptable limits. The monitoring shall make this clear at a sufficiently early stage, and with sufficiently short intervals to allow contingency actions to be undertaken successfully;
- the response time of the instruments and the procedures for analysing the results shall be sufficiently rapid in relation to the possible evolution of the system;
- a plan of contingency actions shall be devised, which may be adopted if the monitoring reveals behaviour outside acceptable limits.

(3)P During construction, the monitoring shall be carried out as planned.

(4)P The results of the monitoring shall be assessed at appropriate stages and the planned contingency actions shall be put into operation if the limits of behaviour are exceeded.

(5)P Monitoring equipment shall either be replaced or extended if it fails to supply reliable data of appropriate type or in sufficient quantity.

2.8 Geotechnical Design Report

(1)P The assumptions, data, methods of calculation and results of the verification of safety and serviceability shall be recorded in the Geotechnical Design Report.

(2) The level of detail of the Geotechnical Design Reports will vary greatly, depending on the type of design. For simple designs, a single sheet may be sufficient.

(3) The Geotechnical Design Report should normally include the following items, with cross-reference to the Ground Investigation Report (see 3.4) and to other documents, which contain more detail:

- a description of the site and surroundings;
- a description of the ground conditions;
- a description of the proposed construction, including actions;
- design values of soil and rock properties, including justification, as appropriate;
- statements on the codes and standards applied;
- statements on the suitability of the site with respect to the proposed construction and the level of acceptable risks;
- geotechnical design calculations and drawings;
- foundation design recommendations;
- a note of items to be checked during construction or requiring maintenance or monitoring.

(4)P The Geotechnical Design Report shall include a plan of supervision and monitoring, as appropriate. Items, which require checking during construction or, which require maintenance after construction shall be clearly identified. When the required checks have been carried out during construction, they shall be recorded in an addendum to the Report.

(5) In relation to supervision and monitoring the Geotechnical Design Report should state:

- the purpose of each set of observations or measurements;
- the parts of the structure, which are to be monitored and the locations at which observations are to be made;
- the frequency with which readings are to be taken;
- the ways in which the results are to be evaluated;
- the range of values within which the results are to be expected;
- the period of time for which monitoring is to continue after construction is complete;
- the parties responsible for making measurements and observations, for interpreting the results obtained and for maintaining the instruments.

(6)P An extract from the Geotechnical Design Report, containing the supervision, monitoring and maintenance requirements for the completed structure, shall be provided to the owner/client.

Section 3 Geotechnical data

3.1 General

(1)P Careful collection, recording and interpretation of geotechnical information shall always be made. This information shall include geology, geomorphology, seismicity, hydrology and history of the site. Indications of the variability of the ground shall be taken into account.

(2)P Geotechnical investigations shall be planned taking into account the construction and performance requirements of the proposed structure. The scope of geotechnical investigations shall be continuously reviewed as new information is obtained during execution of the work.

(3)P Routine field investigations and laboratory testing shall be carried out and reported generally in accordance with internationally recognised standards and recommendations. Deviations from these standards and additional test requirements shall be reported.

(4) Requirements for laboratory and field-testing should be taken from EN 1997-2.

3.2 Geotechnical investigations

3.2.1 General

(1)P Geotechnical investigations shall provide sufficient data concerning the ground and the ground-water conditions at and around the construction site for a proper description of the essential ground properties and a reliable assessment of the characteristic values of the ground parameters to be used in design calculations.

(2)P The composition and amount of the geotechnical investigations shall be adjusted to the particular investigation phase and the geotechnical category (see EN 1997-2, Section 2).

(3) For very large or unusual structures, structures involving abnormal risks or unusual or exceptionally difficult ground or loading conditions, and structures in highly seismic areas, it is possible that the extent of investigations specified in EN 1997 will not be sufficient to meet the design requirements.

(4) If the character and extent of the investigations are related to the Geotechnical Category of the structure, ground conditions that may influence the choice of Geotechnical Category should be determined as early as possible in the investigation.

(5) The investigations should include visual inspections of the site to enable the design assumptions to be verified during construction.

3.2.2 Preliminary investigations

(1)P Preliminary investigations shall be carried out:

- to assess the general suitability of the site;
- to compare alternative sites, if relevant;
- to estimate the changes that may be caused by the proposed works;
- to plan the design and control investigations, including identification of the extent of ground, which may have significant influence on the behaviour of the structure;
- to identify borrow areas, if relevant.

3.2.3 Design investigations

(1)P Design investigations shall be carried out:

- to provide the information required for an adequate design of the temporary and permanent works;
- to provide the information required to plan the method of construction;
- to identify any difficulties that may arise during construction.

(2)P The design investigation shall identify in a reliable way the disposition and properties of all ground relevant to or affected by the proposed construction.

(3)P The parameters, which affect the ability of the structure to satisfy its performance criteria shall be established before the start of the final design.

(4) In order to ensure that the design investigation covers all relevant ground formations, particular attention should be paid to the following geological features:

- ground profile;
- natural or man-made cavities;
- degradation of rocks, soils, or fill materials;
- hydrogeological effects;
- faults, joints and other discontinuities;
- creeping soil and rock masses;
- expansible and collapsible soils and rocks;
- presence of waste or man-made materials.

(5)P The history of the site and its surroundings shall be taken into account.

(6)P The investigation shall be carried out at least through the formations, which are assessed as being relevant to the project.

(7)P The existing ground-water levels shall be established during the investigation. Any free water levels observed during the investigation shall be recorded (see EN 1997-2).

(8) The extreme water levels of any water source, which might influence the ground-water pressures should be established.

(9)P The location and capacities of any dewatering or water abstraction wells in the vicinity of the site shall be established.

3.3 Evaluation of geotechnical parameters

3.3.1 General

(1) In the following requirements concerning the evaluation of geotechnical parameters, only the most commonly used laboratory and field tests have been referred to. Other tests may be used provided their suitability has been demonstrated through comparable experience.

3.3.2 Characterisation of soil and rock type

(1)P The character and basic constituents of the soil or rock shall be identified before the results of other tests are interpreted.

(2)P The material shall be examined, identified and described in accordance with a recognised nomenclature. A geological evaluation shall be made.

(3) Soils should be classified and soil layers described according to an acknowledged geotechnical soil classification and description system.

(4) Rock should be classified in terms of the quality of the solid (stone) material and jointing. Stone quality should be described in terms of weathering, particle organisation, dominant grain size of minerals, and hardness and toughness of the main mineral. Jointing should be characterised in terms of joint type, width, spacing and fill quality.

(5) In addition to visual inspection, a number of tests for classification, identification and quantification of soils and rocks may be used (see EN 1997-2), such as

for soils:

- grain size distribution;
- weight density;
- porosity;
- water content;
- grain shape;
- grain surface roughness;
- density index;
- Atterberg limits;
- swelling;
- carbonate content;
- organic matter content.

for rocks:

- mineralogy;
- petrography;
- water content;
- weight density;
- porosity;
- sound velocity;
- quick water absorption;

- swelling;
- slake-durability index;
- uniaxial compressive strength.

3.3.3 Weight density

(1)P The weight density shall be determined with sufficient accuracy to establish design or characteristic values of the actions that derive from it.

(2) The weight density should be determined on specimens of soil and rock taken from undisturbed samples (see EN 1997-2). Alternatively, it may be derived from well established or documented correlations based on, for example, penetration tests.

3.3.4 Density index

(1)P The density index shall express the degree of compaction of a non-cohesive soil with respect to the loosest and densest condition as defined by standard laboratory procedures.

3.3.5 Degree of compaction

(1)P The degree of compaction of natural ground or fill shall be expressed as the ratio between dry weight density and maximum dry weight density obtained from a standard compaction test.

3.3.6 Shear strength

(1)P In assessing the shear strength of soil, the influence of the following features shall be considered:

- the stress level imposed on the soil;
- anisotropy of strength, especially in clays of low plasticity;
- fissures, especially in stiff clays;
- strain rate effects;
- very large strains where these may occur in a design situation;
- pre-formed slip surfaces;
- time effects;
- sensitivity of cohesive soil;
- degree of saturation.

(2) When the shear strength assessment is based on test results, the level of confidence in the theory used to derive shear strength values should be taken into account, as well as the possible disturbance during sampling and heterogeneity of samples.

(3) As to time effects, it should be considered that the period for which a soil will be effectively undrained depends on its permeability, the availability of free water and the geometry of the situation.

(4)P The values of effective shear strength parameters c' and $\tan \phi'$ shall be assumed to be constant only within the range of stresses for which they have been evaluated.

3.3.7 Soil stiffness

(1)P In assessing the soil stiffness, the following features shall be considered:

- drainage conditions;
- level of mean effective stress;
- natural or artificial pre-consolidation;
- level of imposed shear strain or induced shear stress, this latter often normalised with respect to the shear strength at failure.

(2) Reliable measurements of the stiffness of the ground are often very difficult to obtain from field or laboratory tests. In particular, owing to sample disturbance and other effects, measurements obtained from laboratory specimens often underestimate the in-situ stiffness of the soil. Observations of the behaviour of previous constructions should therefore be analysed wherever available.

3.3.8 Quality and properties of rocks and rock masses

3.3.8.1 General assessment

(1)P In assessing the quality and properties of rocks and rock masses, a distinction shall be drawn between the behaviour of rock material as measured on undisturbed core samples and the behaviour of much larger rock masses, which include structural discontinuities such as bedding planes, joints, shear zones and solution cavities. Consideration shall be given to the following characteristics of the joints:

- spacing;
- orientation;
- aperture;
- persistence (continuity);
- tightness;
- roughness, including the effects of previous movements on the joints;
- filling.

(2)P In addition, when assessing the properties of rocks and rock masses, the following items shall be considered, if relevant:

- in situ stresses;
- water pressure;
- pronounced variations in properties between different layers.

(3) Estimates of rock mass properties, such as:

- strength and stiffness,

- jointing, especially in fractured zones,
- water permeability of the joint system,
- deformation properties of weathered rock,

may be obtained by using the concept of rock mass classification described in EN 1997-2.

(4)P The sensitivity of rocks to e.g. climate or stress changes, shall be assessed. Consideration shall also be given to the influence of chemical degradation on the performance of rock foundations.

(5) In assessing the quality of rocks and rock masses, consideration should be given to the following features:

- some porous soft rocks degrade rapidly to soils of low strength, especially if exposed to weathering;
- some rocks exhibit high solution rates due to ground-water causing channels, caverns and sinkholes, which may develop to the ground surface;
- when unloaded and exposed to the air, certain rocks experience pronounced swelling due to the absorption of water by clay minerals.

3.3.8.2 Uniaxial compressive strength and deformability of rock materials

(1)P In assessing the uniaxial compressive strength and deformability of rock materials the influence of the following features shall be considered:

- the orientation of the axis of loading with respect, for example, to specimen anisotropy, bedding planes, foliation;
- method of sampling, storage history and environment;
- number of specimens tested;
- the geometry of the tested specimens;
- water content and degree of saturation at time of test;
- test duration and stress rate;
- method for determination of the Young's modulus and the axial stress level or levels at which it is determined.

3.3.8.3 Shear strength of joints

(1)P In assessing the shear strength of joints of rock materials, the influence of the following features shall be considered:

- orientation of the joint within the rock test in relation to the assumed direction of actions;
- orientation of the shear test;
- number of specimens tested;
- dimensions of the sheared area;

- pore-water pressure conditions;
- possibility of progressive failure governing the behaviour of the rock in the ground.

(2) Planes of weakness in rock normally coincide with joints or planes of bedding, schistosity or cleavage, or with the interface between soil and rock or concrete and rock. Measurements of the shear strength on these planes should normally be used for the limit equilibrium analysis of rock masses.

3.3.9 Permeability and consolidation parameters of soil and rock

3.3.9.1 Permeability and consolidation parameters of soil

(1)P In assessing permeability and consolidation parameters, the following factors shall be considered:

- the effects of heterogeneity;
- the effects of anisotropy;
- the effects of fissures or faults;
- the effects of stress changes under the proposed loading.

(2) Permeability measurements made on small laboratory samples may not be representative of the in-situ conditions. Whenever possible, in-situ tests, which measure average properties of a large ground volume should therefore be preferred. However, consideration should be given to possible changes in the permeability with increased effective stress above the in-situ value.

(3) Sometimes permeability should be evaluated on the basis of knowledge of the grain size distribution.

3.3.9.2 Permeability parameters of rock

(1)P Since the permeability of rock masses depends mainly on the degree of jointing and the existence of other discontinuities such as fractures and fissures, it shall be measured by appropriate in situ tests or evaluated from local experience.

(2) In situ permeability may be determined by a system of pumping tests combined with flow logging, with due consideration of the spatial, hydrogeological flow conditions around the structure and the mapping of the patterns of joints and other discontinuities.

(3) Laboratory permeability tests should only be used to study the effect of discontinuities, for example, in terms of variable aperture.

3.3.10 Geotechnical parameters from field tests

3.3.10.1 Cone penetration test

(1)P In assessing values of the cone resistance, the sleeve friction and, possibly, the pore-water pressure during penetration, the following aspects shall be taken into account:

- the detailed design of the cone and friction sleeve. This may affect the results significantly and allowance must therefore be made for the type of cone used;

- the results can only be interpreted with confidence when the succession of soil layers is established; in many situations borings will therefore be needed in conjunction with the penetration tests;
- the effects of ground-water and overburden;
- in heterogeneous soils in which widely fluctuating results are recorded, the penetration values shall be selected for the zone of soil relevant to the construction;
- established correlations with other test results, such as density measurements and other forms of penetration testing.

3.3.10.2 Standard penetration and dynamic probing test

(1)P In assessing blow counts, the following features shall be considered:

- type of test;
- detailed description of the test procedure;
- ground-water conditions;
- the influence of the overburden pressure;
- the nature of the ground, particularly if cobbles or coarse gravel are encountered.

3.3.10.3 Vane test

(1)P The following shall be considered when assessing the test results:

- details of the test procedure;
- whether standardised vane equipment has been used;
- whether measurements have been made at several depths to provide a profile of strength in the succession of soil layers;
- skin friction along the rod.

(2) Vane tests may be used for the assessment of undrained shear strength, c_u , of cohesive soil.

NOTE The vane test is a simple and cheap way of checking the trafficability of soft ground for heavy equipment and vehicles.

(3) To obtain derived values of c_u , the measured values should be corrected by a factor based on local experience and depending for example, on the liquid limit, plasticity index and effective vertical stress.

3.3.10.4 Weight sounding test

(1)P In assessing weight sounding test results, the following features shall be taken into account:

- detailed description of the test procedure;
- ground-water conditions;

- influence of overburden pressure;
- nature of the ground, particularly if cobbles or coarse gravel are encountered.

(2) Weight sounding tests may be used for the assessment of soil layer boundaries and the density of non-cohesive soils.

3.3.10.5 Pressuremeter test

(1)P In assessing the values of the limit pressure and the pressuremeter modulus, the following features shall be taken into account:

- the type of equipment;
- the procedure used to install the pressuremeter in the ground.

(2) Test curves, which exhibit more than a moderate degree of disturbance should not be used. Where the limit pressure is not reached during the test, a moderate and conservative extrapolation of the curve may be used to estimate it. For tests in which only the initial part of the pressuremeter curve is determined, general correlations or, preferably, local correlations from the same site may be used conservatively to estimate the limit pressure from the pressuremeter modulus.

3.3.10.6 Dilatometer test

(1)P In assessing dilatometer values the installation procedure shall be taken into account.

(2)P The succession of soil layers and especially some basic parameters such as granularity and degree of saturation shall be determined prior to the test.

(3) If strength parameters are to be evaluated, the penetration resistance should be taken into account.

(4) The dilatometer values should be used as an index for determining derived values of the stiffness moduli of the soil succession.

3.3.10.7 Compactibility tests

(1)P In assessing the compactibility of a fill material, the following features shall be taken into account:

- type of soil or rock;
- grain size distribution;
- grain shape;
- the heterogeneity of the material;
- the degree of saturation or water content;
- type of plant to be used.

(2) When using field measurements (e.g. soundings, dynamic compaction tests, plate load tests, settlement records) to control site compaction, the results of field compaction trials (see 5.3.3(4)) should be related to standard laboratory compaction test values in order to assess the compactibility of a soil or a rock fill.

3.4 Ground Investigation Report

3.4.1 Requirements

(1)P The results of a geotechnical investigation shall be compiled in a Ground Investigation Report, which shall form a part of the Geotechnical Design Report described in 2.8.

(2)P Reference shall be made to EN 1997-2 for information on the use of laboratory and field tests for geotechnical parameters.

(3) The Ground Investigation Report should normally consist of:

- a presentation of all available geotechnical information including geological features and relevant data;
- a geotechnical evaluation of the information, stating the assumptions made in the interpretation of the test results.

The information may be presented as one report or as separate parts.

3.4.2 Presentation of geotechnical information

(1)P The presentation of geotechnical information shall include:

- a factual account of all field and laboratory work;
- documentation of the methods used to carry out the field investigations and the laboratory testing.

The documentation shall be based on the test reports described in EN 1997-2.

(2) In addition, the factual account should include the following information, as relevant:

- names of all consultants and subcontractors;
- purpose and scope of the geotechnical investigation;
- dates between which field and laboratory work was performed;
- field reconnaissance of the general area of the project noting particularly:
 - evidence of ground-water;
 - behaviour of neighbouring structures;
 - exposures in quarries and borrow areas;
 - areas of instability;
 - difficulties during excavation;
- history of the site;
- geology of the site, including faulting;
- survey data;
- information from available aerial photographs;

- local experience of the area;
- information about the seismicity of the area;
- procedures used for sampling and transportation and storage of samples;
- types of field equipment used;
- tabulation of quantities of field and laboratory work, and presentation of field observations, which were made by the supervising field personnel during the subsurface explorations;
- data on fluctuations of any ground-water table with time in the boreholes during the performance of the field work and in piezometers after the completion of the field work;
- compilation of boring logs, including photographs of the cores, with descriptions of subsurface formations based on field descriptions and on the results of the laboratory tests;
- the occurrence, or the possibility of occurrence, of radon;
- data on frost susceptibility of soils;
- grouping and presentation of field and laboratory test results in appendices.

3.4.3 Evaluation of geotechnical information

(1)P The evaluation of the geotechnical information shall include as appropriate:

- a review of the field and laboratory work. Any limitations in the data (e.g. defective, irrelevant, insufficient or inaccurate) shall be pointed out and commented upon. The sampling and sample transportation and storage procedures shall be considered when interpreting the test results. Any particularly adverse test results shall be considered carefully in order to determine if they are misleading or represent a real phenomenon that must be accounted for in the design;
- a review of the derived values of geotechnical parameters;
- any proposals for necessary further field and laboratory work, with comments justifying the need for this extra work. Such proposals shall be accompanied by a detailed programme for the extra investigations to be carried out with specific reference to the questions that have to be answered.

(2) In addition, the evaluation of the geotechnical data should include the following, if relevant:

- tabulation and graphical presentation of the results of the field and laboratory work in relation to the requirements of the project and, if deemed necessary,
- histograms illustrating the range of values of the most relevant data and their distribution;
- depth of the ground-water table and its seasonal fluctuations;
- subsurface profile(s) showing the differentiation of the various formations;
- detailed descriptions of all formations including their physical properties and their deformation and strength characteristics;
- comments on irregularities such as pockets and cavities;
- the range and any grouping of derived values of the geotechnical data for each stratum.

Section 4 Supervision of construction, monitoring and maintenance

4.1 General

(1)P To ensure the safety and quality of a structure, the following shall be undertaken, as appropriate:

- the construction processes and workmanship shall be supervised;
- the performance of the structure shall be monitored during and after construction;
- the structure shall be adequately maintained.

(2)P Supervision of the construction process, including workmanship, and any monitoring of the performance of the structure during and after construction, shall be specified in the Geotechnical Design Report.

(3) Supervision of the construction process, including workmanship, should involve the following, as appropriate:

- checking the validity of the design assumptions;
- identifying the differences between the actual ground conditions and those assumed in the design;
- checking that the construction is carried out according to the design.

(4) Observations and measurements of the behaviour of the structure and its surroundings should be made, as appropriate:

- during construction, to identify any need for remedial measures or alterations to the construction sequence, for example;
- during and post construction, to evaluate the long-term performance.

(5)P Design decisions, which are influenced by the results of the supervision and monitoring shall be clearly identified.

(6) The amount of construction supervision and the quantity of field and laboratory testing required to control and monitor performance should be planned during the design stage.

(7)P In the case of unexpected events, the methods, extent and frequency of monitoring shall be reviewed.

(8)P The level and quality of supervision and monitoring shall be at least equal to those assumed in the design and shall be consistent with the values selected for the design parameters and partial factors.

NOTE Annex J gives a checklist for construction supervision and performance monitoring.

4.2 Supervision

4.2.1 Plan of supervision

(1)P The plan included in the Geotechnical Design Report shall state acceptable limits for the results to be obtained by the supervision.

(2) The plan should specify the type, quality and frequency of supervision, which should be commensurate with:

- the degree of uncertainty in the design assumptions;
- the complexity of the ground and loading conditions;
- the potential risk of failure during construction;
- the feasibility of implementing design modifications or corrective measures during construction.

4.2.2 Inspection and control

(1)P The construction work shall be inspected on a continuous basis and the results of the inspection shall be recorded.

(2) For Geotechnical Category 1, the supervision programme may be limited to inspection, simple quality controls and a qualitative assessment of the performance of the structure.

(3) For Geotechnical Category 2, measurements of ground properties or the behaviour of structures should often be required.

(4) For Geotechnical Category 3, additional measurements should be required during each significant stage of construction.

(5)P Records shall be maintained of the following, as appropriate:

- significant ground and ground-water features;
- sequence of works;
- quality of materials;
- deviations from design;
- as-built drawings;
- results of measurements and of their interpretation;
- observations of the environmental conditions;
- unforeseen events.

(6) Records of temporary works should also be kept. Interruptions to the works, and their condition on re-commencement, should be recorded.

(7)P The results of the inspection and control shall be made available to the designer before any changes are decided.

(8) In general, the design documents and records of what was constructed should be stored for 10 years, unless agreed otherwise. More important documents should be stored for the lifetime of the relevant structure.

4.2.3 Assessment of the design

(1)P The suitability of the construction procedures and the sequence of operations shall be reviewed in the light of the ground conditions, which are encountered; the predicted behaviour

of the structure shall be compared with the observed performance. The design shall be assessed on the basis of the results of the inspection and supervision.

(2) The assessment of the design should include a careful review of the most unfavourable conditions, which occur during construction with regard to:

- ground conditions;
- ground-water conditions;
- actions on the structure;
- environmental impacts and changes including landslides and rockfalls.

4.3 Checking ground conditions

4.3.1 Soil and rock

(1)P The descriptions and geotechnical properties of the soils and rocks in or on which the structure is founded or located shall be checked during construction.

(2) For Geotechnical Category 1, the descriptions of the soils and rocks should be checked by:

- inspecting the site;
- determining the types of soil and rock within the zone of influence of the structure;
- recording descriptions of the soil and rock exposed in excavations.

(3) For Geotechnical Category 2, the geotechnical properties of the soil or rock in or on which the structure is founded or located should also be checked. Additional site investigation may be needed. Representative samples should be recovered and tested to determine the index properties, strength and deformability.

(4) For Geotechnical Category 3, additional requirements should include further investigations and examination of details of the ground or fill conditions, which may have important consequences for the design.

(5) Indirect evidence of the geotechnical properties of the ground (for example, from pile driving records) should be recorded and used to assist in interpreting the ground conditions.

(6)P Deviations from the ground type and properties assumed in the design shall be reported without delay.

NOTE Normally these deviations are reported to the designer.

(7)P The principles used in design shall be checked to ensure that they are appropriate for the geotechnical features of the ground, which are encountered.

4.3.2 Ground-water

(1)P As appropriate, the ground-water levels, pore-water pressures and ground-water chemistry encountered during execution shall be compared with those assumed in the design.

(2) More thorough checks should be performed for sites on which significant variations of ground type and permeability are known or believed to exist.

- (3) For Geotechnical Category 1, checks should usually be based on previously documented experience in the area or on indirect evidence.
- (4) For Geotechnical Categories 2 and 3, direct observations should normally be made of the ground-water conditions if these greatly affect either the method of construction or the performance of the structure.
- (5) Ground-water flow characteristics and the pore-water pressure regime should be obtained by means of piezometers, which preferably should be installed before the start of construction operations. It may sometimes be necessary to install piezometers at large distances from the site as part of the monitoring system.
- (6) If pore-water pressure changes occur during construction that may affect the performance of the structure, pore-water pressures should be monitored until construction is complete or until the pore-water pressures have dissipated to safe values.
- (7) For structures below ground-water level, which may be subject to uplift, pore-water pressures should be monitored until the weight of the structure is sufficient to rule out the possibility of uplift.
- (8) Chemical analysis of mobile water should be performed when any part of the permanent or temporary works may be significantly affected by chemical attack.
- (9)P The effect of construction operations (including processes such as dewatering, grouting and tunnelling) on the ground-water regime shall be checked.
- (10)P Deviations from the ground-water features assumed in the design shall be reported without delay.
- (11)P The principles used in design shall be checked to ensure that they are appropriate for the ground-water features, which are encountered.

4.4 Checking construction

- (1)P Site operations shall be checked for compliance with the method of construction assumed in the design and stated in the Geotechnical Design Report. Observed differences between the design assumptions and the site operations shall be reported without delay.
- (2)P Deviations from the methods of construction assumed in the design and stated in the Geotechnical Design Report shall be explicitly and rationally considered and implemented.
- (3)P The principles followed in design shall be checked to ensure that they are appropriate for the sequence of construction operations, which are used.
- (4) For Geotechnical Category 1, a formal construction schedule need not normally be included in the Geotechnical Design Report.

NOTE The sequence of construction operations is normally decided by the contractor.

- (5) For Geotechnical Categories 2 and 3, the Geotechnical Design Report may give the sequence of construction operations envisaged in the design.

NOTE Alternatively, the Geotechnical Design Report can state that the sequence of construction is to be decided by the contractor.

4.5 Monitoring

(1)P Monitoring shall be applied:

- to check the validity of predictions of performance made during the design;
- to ensure that the structure will continue to perform as required after completion.

(2)P The monitoring programme shall be carried out in accordance with the Geotechnical Design Report (see 2.8(3)).

(3) Records of the actual performance of structures should be made in order to collect databases of comparable experience.

(4) Monitoring should include measurement of the following:

- deformations of the ground affected by the structure;
- values of actions;
- values of contact pressure between ground and structure;
- pore-water pressures;
- forces and displacements (vertical or horizontal movements, rotations or distortions) in structural members.

(5) Results of measurements should be integrated with qualitative observations including architectural appearance.

(6) The length of any post-construction monitoring period should be altered as a result of observations made during construction. For structures that may impact unfavourably on appreciable parts of the surrounding physical environment, or for which failure may involve abnormal risks to property or life, monitoring should be required for more than ten years after construction is complete, or throughout the life of the structure.

(7)P The results obtained from monitoring shall always be evaluated and interpreted and this shall normally be done in a quantitative manner.

(8) For Geotechnical Category 1, the evaluation of performance may be simple, qualitative and based on inspection.

(9) For Geotechnical Category 2, the evaluation of performance may be based on measurements of movements of selected points on the structure.

(10) For Geotechnical Category 3, the evaluation of performance should normally be based on the measurement of displacements and analyses, which take account of the sequence of construction operations.

(11)P For structures that may have an adverse effect on ground or ground-water conditions, the possibility of leakage or of alterations to the pattern of ground-water flow, especially when fine grained soils are involved, shall be taken into account when planning the monitoring programme.

(12) Examples of this type of structure are:

- water retaining structures;
- structures intended to control seepage;

- tunnels;
- large underground structures;
- deep basements;
- slopes and earth retaining structures;
- ground improvements.

4.6 Maintenance

(1)P The maintenance required to ensure the safety and serviceability of the structure shall be specified.

NOTE Normally this is specified to the owner/client.

(2) The maintenance specifications should provide information on:

- critical parts of the structure, which require regular inspection;
- works prohibited without a design review of the structure prior to their execution;
- frequency of the inspection.

Section 5 Fill, dewatering, ground improvement and reinforcement

5.1 General

(1)P The provisions in this Section shall apply where adequate ground conditions are achieved by:

- placing natural soil, crushed rock, blasted stone or certain waste products;
- dewatering;
- treating ground;
- reinforcing ground.

NOTE 1 Situations where soil or granular material is placed for engineering purposes include:

- fills beneath foundations and ground slabs;
- backfill to excavations and retaining structures;
- general landfill including hydraulic fill, landscape mounds and spoil heaps;
- embankments for small dams and infrastructure.

NOTE 2 Dewatering of ground may be temporary or permanent.

NOTE 3 Ground, which is treated to improve its properties may be either natural ground or fill. The ground improvement may be either temporary or permanent.

(2)P Design procedures for geotechnical works that include the use of fill, dewatering, improvement and reinforcement shall be those presented in Sections 6 to 12.

5.2 Fundamental requirements

(1)P Fill and dewatered, improved or reinforced ground shall be capable of sustaining the actions arising from its function and from its environment.

(2)P These fundamental requirements shall also be satisfied for the ground on which the fill is placed.

5.3 Fill construction

5.3.1 Principles

(1)P When designing fill constructions it shall be considered that the adequacy of the fill depends on the following:

- good material handling properties,
- adequate engineering properties after compaction.

(2) Transport and placement of the fill should be considered in the design.

5.3.2 Selection of fill material

(1)P The criteria for specifying material as suitable for use as fill shall be based on achieving adequate strength, stiffness, durability and permeability after compaction. These criteria shall take account of the purpose of the fill and the requirements of any structure to be placed on it.

(2) Suitable fill materials may include most graded natural granular materials and certain waste products such as selected colliery waste and pulverised fuel ash. Some manufactured materials, such as light aggregate, may also be used in some circumstances. Some cohesive materials may be suitable but require particular care.

(3)P The following aspects shall be taken into account when specifying a fill material:

- grading;
- resistance to crushing;
- compactibility;
- permeability;
- plasticity;
- strength of underlying ground;
- organic content;
- chemical aggression;
- pollution effects;
- solubility;
- susceptibility to volume changes (swelling clays and collapsible materials);
- low temperature and frost susceptibility;
- resistance to weathering;
- effect of excavation, transportation and placement;
- possibility of cementation occurring after placement (e.g. blast furnace slags).

(4) If local materials in their natural state are not suitable for use as fill, it can be necessary to adopt one of the following procedures:

- adjust the water content;
- mix with cement, lime or other materials;
- crush, sieve or wash;
- protect with appropriate material;
- use drainage layers.

(5) Frozen, expansive or soluble soils should not normally be used as fill material.

(6)P When the selected material contains potentially aggressive or polluting chemicals, adequate provisions shall be adopted to prevent it from attacking structures or services or polluting the ground-water. Such materials shall only be used in large amounts in permanently monitored locations.

(7)P In case of doubt, the fill material shall be tested at source to ensure that it is suitable for its intended purpose. The type, number and frequency of the tests shall be selected according to the type and heterogeneity of the material and the nature of the project.

(8) In Geotechnical Category 1, inspection of the material may often be sufficient.

(9)P Material used for fill with specified severe requirements regarding bearing resistance, settlement and stability shall not contain matter such as snow, ice or peat in any significant amount.

(10) In fills with no specified requirements for bearing resistance, settlement or stability, the fill material may contain small amounts of snow, ice or peat.

5.3.3 Selection of procedures for fill placement and compaction

(1)P Compaction criteria shall be established for each zone or layer of fill, related to its purpose and performance requirements.

(2)P The procedures for fill placement and compaction shall be specified in such a way that stability of the fill is ensured during the entire construction period and the natural subsoil is not adversely affected.

(3)P The compaction procedure for fill shall be specified depending on the compaction criteria and on the following:

- the origin and nature of the material;
- the placement method;
- the placement water content and its possible variations;
- the initial and final thickness of the lift;
- the local climatic conditions;
- the uniformity of compaction;
- the nature of underlying ground.

(4) In order to develop an appropriate procedure for compaction, a trial compaction should be performed at the site using the intended material and compaction equipment. This allows the determination of the compaction procedure (method of placement, compaction equipment, layer thickness, number of passes, adequate techniques for transportation, amount of water that shall be added) to be followed. A trial compaction may also be used to establish the control criteria.

(5) Where there is a possibility of rainfall during the placement of cohesive fill material, the fill surface should at all stages be profiled so as to permit adequate run-off.

(6) At temperatures below freezing, fill may require heating before placement and frost protection of the fill surface. The need of these measures should be evaluated case-by-case, taking into account the quality of the fill material and the required degree of compaction.

(7)P Backfill placed around foundations and beneath floor slabs shall be compacted such that damaging subsidence does not occur.

(8) Fill should be placed on an undisturbed and drained ground surface. Any mixing of the fill with the ground should be prevented by using a filter textile or filter layer.

(9) Before placing fill underwater, all soft material encountered should be removed by dredging or other means.

5.3.4 Checking the fill

(1)P Fill shall be inspected or tested to ensure that the material, its placement water content and the compaction procedures comply with the specification.

(2) Testing need not be performed for some combinations of materials and compaction procedures if the compaction procedure has been proved by a field trial or by comparable experience.

(3) Compaction should be tested by one of the following methods:

- measurement of dry density and, if required by the design, measurement of the water content;
- measurement of properties such as, for example, penetration resistance or stiffness. Such measurement cannot always determine if satisfactory compaction has been achieved in cohesive soils.

(4) Minimum fill densities determined, for example, by Proctor percentages, should be specified and checked on site.

(5) For rock fill or fill containing a large amount of coarse particles, compaction should be checked by field methods. The Proctor test is not applicable to these materials.

(6) Site checking (see EN 1997-2) may be made by one of the following:

- ensuring that compaction has been performed according to the procedure deduced from a field trial or from comparable experience;
- checking that the settlement induced by an additional pass of the compaction equipment is equal to or less than a specified value;
- plate loading tests;
- seismic or dynamic methods.

(7)P In cases where over-compaction is not acceptable, an upper bound limit for the compaction shall be specified.

(8) Over-compaction can cause the following undesirable effects:

- the development of slickensides and high soil stiffnesses in slopes;
- high earth pressures on buried and earth retaining structures;
- crushing of materials such as soft rocks, slags and volcanic sands used as light weight fills.

5.4 Dewatering

(1)P Any scheme for removing water from the ground or for lowering the water pressure shall be based on the results of a geotechnical or hydrogeological investigation.

(2) Water may be removed from the ground by gravity drainage, by pumping from sumps, well points or bored wells, or by electro-osmosis. The scheme adopted will depend on:

- the existing ground and ground-water conditions;
- the characteristics of the project: e.g. excavation depth and extent of dewatering.

(3) Part of the dewatering scheme may be a system of recharge wells at some distance from the excavation.

(4) In the dewatering scheme the following conditions should be considered, as appropriate:

- in the case of excavations, the sides of the excavation remain stable at all times under the effect of ground-water lowering; also, excessive heaving or rupture of the base, for example due to excessive water pressure beneath a less permeable layer, does not occur;
- the scheme does not lead to excessive settlements or damage to nearby structures;
- the scheme avoids excessive loss of ground by seepage from the sides or base of the excavation;
- except in the case of fairly uniformly graded material, which can establish itself as a filter material, adequate filters are provided around the sumps to ensure that there is no significant transportation of soil with the pumped water;
- water removed from an excavation is normally discharged far enough from the excavated area;
- the dewatering scheme is so designed, arranged and installed as to maintain the water levels and pore-water pressures anticipated in the design without significant fluctuations;
- there is adequate margin of pumping capacity and back-up capacity is available in the case of breakdown;
- when allowing the ground-water to return to its original level, care is taken to prevent problems such as collapse of soils having a sensitive structure, e.g. loose sand;
- the scheme does not lead to excessive transport of contaminated water to the excavation;
- the scheme does not lead to excessive extraction in a drinking water catchment area.

(5)P The effectiveness of dewatering shall be checked by monitoring the ground-water level, the pore-water pressures and the ground movements, as necessary. Data shall be reviewed and interpreted frequently to determine the effects of dewatering on the ground conditions and on the behaviour of nearby structures.

(6)P If a pumping operation is to continue over a long period of time, the ground-water shall be checked for the presence of dissolved salts and gases, which could either result in corrosion of the well screens or cause clogging of the screens by the precipitation of salts.

(7)P Systems for long term dewatering shall be designed to prevent clogging by bacterial action or other causes.

5.5 Ground improvement and reinforcement

(1)P A geotechnical investigation of the initial ground conditions shall be carried out before any ground improvement or reinforcement method is chosen or used.

(2)P The ground improvement method for a particular situation shall be designed taking into account the following factors where appropriate:

- thickness and properties of the ground or fill material;
- magnitude of water pressure in the various strata;
- nature, size and position of the structure to be supported by the ground;
- prevention of damage to adjacent structures or services;
- if the ground improvement is temporary or permanent;
- in terms of anticipated deformations, the relationship between the ground improvement method and the construction sequence;
- the effects on the environment including pollution by toxic substances or changes in ground-water level;
- the long-term deterioration of materials.

(3)P The effectiveness of the ground improvement shall be checked against the acceptance criteria by determining the induced changes in the appropriate ground properties.

Section 6 Spread foundations

6.1 General

(1)P The provisions of this Section apply to spread foundations including pads, strips and rafts.

(2) Some of the provisions may be applied to deep foundations such as caissons.

6.2 Limit states

(1)P The following limit states shall be considered and an appropriate list shall be compiled:

- loss of overall stability;
- bearing resistance failure, punching failure, squeezing;
- failure by sliding;
- combined failure in the ground and in the structure;
- structural failure due to foundation movement;
- excessive settlements;
- excessive heave due to swelling, frost and other causes;
- unacceptable vibrations.

6.3 Actions and design situations

(1)P Design situations shall be selected in accordance with 2.2.

(2) The actions listed in 2.4.2(4) should be considered when selecting the limit states for calculation.

(3) If structural stiffness is significant, an analysis of the interaction between the structure and the ground should be performed in order to determine the distribution of actions.

6.4 Design and construction considerations

(1)P When choosing the depth of a spread foundation the following shall be considered:

- reaching an adequate bearing stratum;
- the depth above which shrinkage and swelling of clay soils, due to seasonal weather changes, or to trees and shrubs, may cause appreciable movements;
- the depth above which frost damage may occur;
- the level of the water table in the ground and the problems, which may occur if excavation for the foundation is required below this level;
- possible ground movements and reductions in the strength of the bearing stratum by seepage or climatic effects or by construction procedures;
- the effects of excavations on nearby foundations and structures;

- anticipated excavations for services close to the foundation;
- high or low temperatures transmitted from the building;
- the possibility of scour;
- the effects of variation of water content due to long periods of drought, and subsequent periods of rain, on the properties of volume-unstable soils in arid climatic areas;
- the presence of soluble materials, e.g. limestone, claystone, gypsum, salt rocks;

(2) Frost damage will not occur if:

- the soil is not frost-susceptible;
- the foundation level is beneath frost-free depth;
- frost is eliminated by insulation.

(3) EN-ISO 13793 may be applied for frost protecting measures for building foundations.

(4)P In addition to fulfilling the performance requirements, the design foundation width shall take account of practical considerations such as economic excavation, setting out tolerances, working space requirements and the dimensions of the wall or column supported by the foundation.

(5)P One of the following design methods shall be used for spread foundations:

- a direct method, in which separate analyses are carried out for each limit state. When checking against an ultimate limit state, the calculation shall model as closely as possible the failure mechanism, which is envisaged. When checking against a serviceability limit state, a settlement calculation shall be used;
- an indirect method using comparable experience and the results of field or laboratory measurements or observations, and chosen in relation to serviceability limit state loads so as to satisfy the requirements of all relevant limit states;
- a prescriptive method in which a presumed bearing resistance is used (see 2.5).

(6) Calculation models for ultimate and serviceability limit state design of spread foundations on soil given in 6.5 and 6.6 respectively should be applied. Presumed bearing pressures for the design of spread foundations on rock should be applied according to 6.7.

6.5 Ultimate limit state design

6.5.1 Overall stability

(1)P Overall stability, with or without the foundations, shall be checked particularly in the following situations:

- near or on a natural or man-made slope;
- near an excavation or a retaining wall;
- near a river, a canal, a lake, a reservoir or the sea shore;
- near mine workings or buried structures.

(2)P For such situations, it shall be demonstrated using the principles described in Section 11, that a stability failure of the ground mass containing the foundation is sufficiently improbable.

6.5.2 Bearing resistance

6.5.2.1 General

(1)P The following inequality shall be satisfied for all ultimate limit states:

$$V_d \leq R_d \quad (6.1)$$

(2)P R_d shall be calculated according to 2.4.

(3)P V_d shall include the weight of the foundation, the weight of any backfill material and all earth pressures, either favourable or unfavourable. Water pressures not caused by the foundation load shall be included as actions.

6.5.2.2 Analytical method

(1) A commonly recognized analytical method should be used.

NOTE The sample analytical calculation for bearing resistance given in Annex D may be used.

(2)P An analytical evaluation of the short-term and long-term values of R_d shall be considered, particularly in fine-grained soils.

(3)P Where the soil or rock mass beneath a foundation presents a definite structural pattern of layering or other discontinuities, the assumed rupture mechanism and the selected shear strength and deformation parameters shall take into account the structural characteristics of the ground.

(4)P When calculating the design bearing resistance of a foundation on layered deposits, the properties of which vary greatly between one another, the design values of the ground parameters shall be determined for each layer.

(5) Where a strong formation underlies a weak formation, the bearing resistance may be calculated using the shear strength parameters of the weak formation. For the reverse situation, punching failure should be checked.

(6) Analytical methods are often not applicable to the design situations described in 6.5.2.2(3)P, 6.5.2.2(4)P and 6.5.2.2(5). Numerical procedures should then be applied to determine the most unfavourable failure mechanism.

(7) The overall stability calculations described in Section 11 may be applied.

6.5.2.3 Semi-empirical method

(1) A commonly recognized semi-empirical method should be used.

NOTE The sample semi-empirical method for bearing resistance estimation using pressuremeter test results given in Annex E is recommended.

6.5.2.4 Prescriptive method using presumed bearing resistance

(1) A commonly recognized prescriptive method based on presumed bearing resistance should be used.

NOTE The sample method for deriving the presumed bearing resistance for spread foundations on rock given in Annex G is recommended. When such a method is applied, the design result should be evaluated on the basis of comparable experience.

6.5.3 Sliding resistance

(1)P Where the loading is not normal to the foundation base, foundations shall be checked against failure by sliding on the base.

(2)P The following inequality shall be satisfied:

$$H_d \leq R_d + R_{p;d} \quad (6.2)$$

(3)P H_d shall include the design values of any active earth forces imposed on the foundation.

(4)P R_d shall be calculated according to 2.4.

(5) The values of R_d and $R_{p;d}$ should be related to the scale of movement anticipated under the limit state of loading considered. For large movements, the possible relevance of post-peak behaviour should be considered. The value of $R_{p;d}$ selected should reflect the anticipated life of the structure.

(6)P For foundations bearing within the zone of seasonal movements of clay soils, the possibility that the clay could shrink away from the vertical faces of foundations shall be considered.

(7)P The possibility that the soil in front of the foundation may be removed by erosion or human activity shall be considered.

(8)P For drained conditions, the design shear resistance, R_d , shall be calculated either by factoring the ground properties or the ground resistance as follows;

$$R_d = V_d \tan \delta_d \quad (6.3a)$$

or

$$R_d = (V_d \tan \delta_k) / \gamma_{R;h} \quad (6.3b)$$

NOTE In design procedures where the effects of actions are factored, the partial factor for the actions (γ_F) is 1,0 and $V_d = V_k$ in equation (6.3b).

(9)P In determining V_d , account shall be taken of whether H_d and V_d are dependent or independent actions.

(10) The design friction angle δ_d may be assumed equal to the design value of the effective critical state angle of shearing resistance, $\phi_{cv;d}$, for cast-in-situ concrete foundations and equal to $2/3 \phi_{cv;d}$ for smooth precast foundations. Any effective cohesion c' should be neglected.

(11)P For undrained conditions, the design shearing resistance, R_d , shall be calculated either by factoring the ground properties or the ground resistance as follows:

$$\boxed{AC1} R_d = A c_{u;d} \boxed{AC1} \quad (6.4a)$$

or

$$\overline{R_d} = (A_{C_{u;k}}) / \gamma_{R;h} \overline{AC_1} \quad (6.4b)$$

(12)P If it is possible for water or air to reach the interface between a foundation and an undrained clay subgrade, the following check shall be made:

$$R_d \leq 0,4 V_d \quad (6.5)$$

(13) Requirement (6.5) may only be disregarded if the formation of a gap between the foundation and the ground will be prevented by suction in areas where there is no positive bearing pressure.

6.5.4 Loads with large eccentricities

(1)P Special precautions shall be taken where the eccentricity of loading exceeds 1/3 of the width of a rectangular footing or 0,6 of the radius of a circular footing.

Such precautions include:

- careful review of the design values of actions in accordance with 2.4.2;
- designing the location of the foundation edge by taking into account the magnitude of construction tolerances.

(2) Unless special care is taken during the works, tolerances up to 0,10 m should be considered.

6.5.5 Structural failure due to foundation movement

(1)P Differential vertical and horizontal foundation displacements shall be considered to ensure that they do not lead to an ultimate limit state occurring in the supported structure.

(2) A presumed bearing pressure may be adopted (see 2.5) provided displacements will not cause an ultimate limit state in the structure.

(3)P In ground that may swell, the potential differential heave shall be assessed and the foundations and structure designed to resist or accommodate it.

6.6 Serviceability limit state design

6.6.1 General

(1)P Account shall be taken of displacements caused by actions on the foundation, such as those listed in 2.4.2(4).

(2)P In assessing the magnitude of foundation displacements, account shall be taken of comparable experience, as defined in 1.5.2.2. If necessary, calculations of displacements shall also be carried out.

(3)P For soft clays, settlement calculations shall always be carried out.

(4) For spread foundations on stiff and firm clays in Geotechnical Categories 2 and 3, calculations of vertical displacement (settlement) should usually be undertaken. Methods that may be used to calculate settlements caused by loads on the foundation are given in 6.6.2.

- (5)P The serviceability limit state design loads shall be used when calculating foundation displacements for comparison with serviceability criteria.
- (6) Calculations of settlements should not be regarded as accurate. They merely provide an approximate indication.
- (7)P Foundation displacements shall be considered both in terms of displacement of the entire foundation and differential displacements of parts of the foundation.
- (8)P The effect of neighbouring foundations and fills shall be taken into account when calculating the stress increase in the ground and its influence on ground compressibility.
- (9)P The possible range of relative rotations of the foundation shall be assessed and compared with the relevant limiting values for movements discussed in 2.4.9.

6.6.2 Settlement

- (1)P Calculations of settlements shall include both immediate and delayed settlement.
- (2) The following three components of settlement should be considered for partially or fully saturated soils:
- s_0 : immediate settlement; for fully-saturated soil due to shear deformation at constant volume, and for partially-saturated soil due to both shear deformation and volume reduction;
 - s_1 : settlement caused by consolidation;
 - s_2 : settlement caused by creep.
- (3) Commonly recognized methods for evaluating settlements should be used.

NOTE The sample methods for evaluating settlements s_0 and s_1 given in Annex F may be applied.

- (4) Special consideration should be given to soils such as organic soils and soft clays, in which settlement may be prolonged almost indefinitely due to creep.
- (5) The depth of the compressible soil layer to be considered when calculating settlement should depend on the size and shape of the foundation, the variation in soil stiffness with depth and the spacing of foundation elements.
- (6) This depth may normally be taken as the depth at which the effective vertical stress due to the foundation load is 20 % of the effective overburden stress.
- (7) For many cases this depth may also be roughly estimated as 1 to 2 times the foundation width, but may be reduced for lightly-loaded, wider foundation rafts.

NOTE This approach is not valid for very soft soils.

- (8)P Any possible additional settlement caused by self-weight compaction of the soil shall be assessed.
- (9) The following should be considered:
- the possible effects of self-weight, flooding and vibration on fill and collapsible soils;
 - the effects of stress changes on crushable sands.

(10)P Either linear or non-linear models of the ground stiffness shall be adopted, as appropriate.

(11)P To ensure the avoidance of a serviceability limit state, assessment of differential settlements and relative rotations shall take account of both the distribution of loads and the possible variability of the ground.

(12) Differential settlement calculations that ignore the stiffness of the structure tend to be over-predictions. An analysis of ground-structure interaction may be used to justify reduced values of differential settlements.

(13) Allowance should be made for differential settlement caused by variability of the ground unless it is prevented by the stiffness of the structure.

(14) For spread foundations on natural ground, it should be taken into account that some differential settlement normally occurs even if the calculation predicts uniform settlement only.

(15) The tilting of an eccentrically loaded foundation should be estimated by assuming a linear bearing pressure distribution and then calculating the settlement at the corner points of the foundation, using the vertical stress distribution in the ground beneath each corner point and the settlement calculation methods described above.

(16) For conventional structures founded on clays, the ratio of the bearing capacity of the ground, at its initial undrained shear strength, to the applied serviceability loading should be calculated (see 2.4.8(4)). If this ratio is less than 3, calculations of settlements should always be undertaken. If the ratio is less than 2, the calculations should take account of non-linear stiffness effects in the ground.

6.6.3 Heave

(1)P The following causes of heave shall be distinguished:

- reduction of effective stress;
- volume expansion of partly saturated soil;
- heave due to constant volume conditions in fully saturated soil, caused by settlement of an adjacent structure.

(2)P Calculations of heave shall include both immediate and delayed heave.

6.6.4 Vibration analysis

(1) P Foundations for structures subjected to vibrations or to vibrating loads shall be designed to ensure that vibrations will not cause excessive settlements.

(2) Precautions should be taken to ensure that resonance will not occur between the frequency of the dynamic load and a critical frequency in the foundation-ground system, and to ensure that liquefaction will not occur in the ground.

(3)P Vibrations caused by earthquakes shall be considered using EN 1998.

6.7 Foundations on rock; additional design considerations

(1)P The design of spread foundations on rock shall take account of the following features:

- the deformability and strength of the rock mass and the permissible settlement of the supported structure;

- the presence of any weak layers, for example solution features or fault zones, beneath the foundation;
- the presence of bedding joints and other discontinuities and their characteristics (for example filling, continuity, width, spacing);
- the state of weathering, decomposition and fracturing of the rock;
- disturbance of the natural state of the rock caused by construction activities, such as, for example, underground works or slope excavation, being near to the foundation.

(2) Spread foundations on rock may normally be designed using the method of presumed bearing pressures. For strong intact igneous rocks, gneissic rocks, limestones and sandstones, the presumed bearing pressure is limited by the compressive strength of the concrete foundation.

NOTE The recommended method for deriving presumed bearing resistances for spread foundations on rock is given in Annex G.

(3) The settlement of a foundation may be assessed on the basis of comparable experience related to rock mass classification.

6.8 Structural design of spread foundations

(1)P Structural failure of a spread foundation shall be prevented in accordance with 2.4.6.4.

(2) The bearing pressure beneath a stiff foundation may be assumed to be distributed linearly. A more detailed analysis of soil-structure interaction may be used to justify a more economic design.

(3) The distribution of bearing pressure beneath a flexible foundation may be derived by modelling the foundation as a beam or raft resting on a deforming continuum or series of springs, with appropriate stiffness and strength.

(4)P The serviceability of strip and raft foundations shall be checked assuming serviceability limit state loading and a distribution of bearing pressure corresponding to the deformation of the foundation and the ground.

(5) For design situations with concentrated loads acting on a strip or raft foundation, forces and bending moments in the foundation may be derived from a subgrade reaction model of the ground, using linear elasticity. The moduli of subgrade reaction may be assessed by a settlement analysis with an appropriate estimate of the bearing pressure distribution. The moduli may be adjusted so that the computed bearing pressures do not exceed values for which linear behaviour may be assumed.

(6) Total and differential settlements of the structure as a whole should be calculated in accordance with 6.6.2. For this purpose, subgrade reaction models are often not appropriate. More precise methods, such as finite element computations, should be used when ground-structure interaction has a dominant effect.

6.9 Preparation of the subsoil

(1)P The subsoil shall be prepared with great care. Roots, obstacles and enclosures of weak soil shall be removed without disturbing the ground. Any resulting holes shall be filled with soil (or other material) to replicate the stiffness of the undisturbed ground.

(2) In soils susceptible to disturbance, such as clay, the sequence of excavation for a spread foundation should be specified to minimise disturbance. Usually it is sufficient to excavate in

horizontal slices. In cases where heave is to be controlled, excavation should be in alternate trenches, the concrete being cast in each trench before excavating intermediate ones.

Section 7 Pile foundations

7.1 General

(1)P The provisions of this Section apply to end-bearing piles, friction piles, tension piles and transversely loaded piles installed by driving, by jacking, and by screwing or boring with or without grouting.

(2) The provisions of this Section should not be applied directly to the design of piles that are intended as settlement reducers, such as in some piled raft foundations.

(3)P The following standards shall apply to the execution of piles:

- EN 1536:1999, for bored piles
- EN 12063:2000, for sheet pile walls,
- EN 12699:2000, for displacement piles.

AC1 — EN 14199:2005, for micropiles AC1

AC1 *Note deleted* AC1

7.2 Limit states

(1)P The following limit states shall be considered and an appropriate list shall be compiled:

- loss of overall stability;
- bearing resistance failure of the pile foundation;
- uplift or insufficient tensile resistance of the pile foundation;
- failure in the ground due to transverse loading of the pile foundation;
- structural failure of the pile in compression, tension, bending, buckling or shear;
- combined failure in the ground and in the pile foundation;
- combined failure in the ground and in the structure;
- excessive settlement;
- excessive heave;
- excessive lateral movement;
- unacceptable vibrations.

7.3 Actions and design situations

7.3.1 General

(1) The actions listed in 2.4.2(4) should be considered when selecting the design situations.

(2) Piles can be loaded axially and/or transversely.

(3)P Design situations shall be derived in accordance with 2.2.

(4) An analysis of the interaction between structure, pile foundation and ground can be necessary to prove that the limit state requirements are met.

7.3.2 Actions due to ground displacement

7.3.2.1 General

(1)P Ground in which piles are located may be subject to displacement caused by consolidation, swelling, adjacent loads, creeping soil, landslides or earthquakes. Consideration shall be given to these phenomena as they can affect the piles by causing downdrag (negative skin friction), heave, stretching, transverse loading and displacement.

(2) For these situations, the design values of the strength and stiffness of the moving ground should usually be upper values.

(3)P One of the two following approaches shall be adopted for design:

- the ground displacement is treated as an action. An interaction analysis is then carried out to determine the forces, displacements and strains in the pile;
- an upper bound to the force, which the ground could transmit to the pile shall be introduced as the design action. Evaluation of this force shall take account of the strength of the soil and the source of the load, represented by the weight or compression of the moving soil or the magnitude of disturbing actions.

7.3.2.2 Downdrag (negative skin friction)

(1)P If ultimate limit state design calculations are carried out with the downdrag load as an action, its value shall be the maximum, which could be generated by the downward movement of the ground relative to the pile.

(2) Calculation of maximum downdrag loads should take account of the shear resistance at the interface between the soil and the pile shaft and downward movement of the ground due to self-weight compression and any surface load around the pile.

(3) An upper bound to the downdrag load on a group of piles may be calculated from the weight of the surcharge causing the movement and taking into account any changes in ground-water pressure due to ground-water lowering, consolidation or pile driving.

(4) Where settlement of the ground after pile installation is expected to be small, an economic design may be obtained by treating the settlement of the ground as the action and carrying out an interaction analysis.

(5)P The design value of the settlement of the ground shall be derived taking account of material weight densities and compressibility in accordance with 2.4.3.

(6) Interaction calculations should take account of the displacement of the pile relative to the surrounding moving ground, the shear resistance of the soil along the shaft of the pile, the weight of the soil and the expected surface loads around each pile, which are the cause of the downdrag.

(7) Normally, downdrag and transient loading need not be considered simultaneously in load combinations.

7.3.2.3 Heave

(1)P In considering the effect of heave, or upward loads, which may be generated along the pile shaft, the movement of the ground shall generally be treated as an action.

NOTE 1 Expansion or heave of the ground can result from unloading, excavation, frost action or driving of adjacent piles. It can also be due to an increase of the ground-water content resulting from the removal of trees, cessation of abstraction from aquifers, prevention (by new construction) of evaporation and from accidents.

NOTE 2 Heave may take place during construction, before piles are loaded by the structure, and may cause unacceptable uplift or structural failure of the piles.

7.3.2.4 Transverse loading

(1)P Consideration shall be given to transverse actions originating from ground movements around a pile.

(2) Consideration should be given to the following list of design situations, which may result in transverse actions on a pile:

- different amounts of surcharge on either side of a pile foundation (e.g. in or near an embankment);
- different levels of excavation on either side of a pile foundation (e.g. in or near a cutting);
- a pile foundation constructed in a creeping slope;
- inclined piles in settling ground;
- piles in a seismic region.

(3) Transverse loading should normally be evaluated by considering the interaction between the piles, treated as stiff or flexible beams, and the moving soil mass. When the horizontal deformation of weak soil layers is large and the piles are widely spaced, the resulting transverse loading of the piles depends mainly on the shear strength of the weak soil layers.

7.4 Design methods and design considerations

7.4.1 Design methods

(1)P The design shall be based on one of the following approaches:

- the results of static load tests, which have been demonstrated, by means of calculations or otherwise, to be consistent with other relevant experience;
- empirical or analytical calculation methods whose validity has been demonstrated by static load tests in comparable situations;
- the results of dynamic load tests whose validity has been demonstrated by static load tests in comparable situations;
- the observed performance of a comparable pile foundation, provided that this approach is supported by the results of site investigation and ground testing.

(2) Design values for parameters used in the calculations should be in general accordance with Section 3, but the results of load tests may also be taken into account in selecting parameter values.

(3) Static load tests may be carried out on trial piles, installed for test purposes only, before the design is finalised, or on working piles, which form part of the foundation.

7.4.2 Design considerations

(1)P The behaviour of individual piles and pile groups and the stiffness and strength of the structure connecting the piles shall be considered.

(2)P In selecting calculation methods and parameter values and in using load test results, the duration and variation in time of the loading shall be considered.

(3)P Planned future placement or removal of overburden or potential changes in the ground-water regime shall be considered, both in calculations and in the interpretation of load test results.

(4)P The choice of type of pile, including the quality of the pile material and the method of installation, shall take into account:

- the ground and ground-water conditions on the site, including the presence or possibility of obstructions in the ground;
- the stresses generated in the pile during installation;
- the possibility of preserving and checking the integrity of the pile being installed;
- the effect of the method and sequence of pile installation on piles, which have already been installed and on adjacent structures or services;
- the tolerances within, which the pile can be installed reliably;
- the deleterious effects of chemicals in the ground;
- the possibility of connecting different ground-water regimes;
- the handling and transportation of piles;
- the effects of pile construction on neighbouring buildings.

(5) In considering the aspects listed above, the following items should receive attention:

- the spacing of the piles in pile groups;
- displacement or vibration of adjacent structures due to pile installation;
- the type of hammer or vibrator used;
- the dynamic stresses in the pile during driving;
- for those types of bored pile where a fluid is used inside the borehole, the need to keep the pressure of the fluid at a level to ensure that the borehole will not collapse and that hydraulic failure of the base will not occur;
- cleaning of the base and sometimes the shaft of the borehole, especially under bentonite, to remove remoulded materials;
- local instability of a shaft during concreting, which may cause a soil inclusion within the pile;
- ingress of soil or water into the section of a cast-in-situ pile and possible disturbance of wet concrete by the flow of water through it;
- the effect of unsaturated sand layers around a pile extracting water from the concrete;

- the retarding influence of chemicals in the soil;
- soil compaction due to the driving of displacement piles;
- soil disturbance due to the boring of a pile shaft.

7.5 Pile load tests

7.5.1 General

(1)P Pile load tests shall be carried out in the following situations:

- when using a type of pile or installation method for which there is no comparable experience;
- when the piles have not been tested under comparable soil and loading conditions;
- when the piles will be subject to loading for which theory and experience do not provide sufficient confidence in the design. The pile testing procedure shall then provide loading similar to the anticipated loading;
- when observations during the process of installation indicate pile behaviour that deviates strongly and unfavourably from the behaviour anticipated on the basis of the site investigation or experience, and when additional ground investigations do not clarify the reasons for this deviation.

(2) Pile load tests may be used to:

- assess the suitability of the construction method;
- determine the response of a representative pile and the surrounding ground to load, both in terms of settlement and limit load;
- to allow judgement of the overall pile foundation.

(3) Where load tests are not practical due to difficulties in modelling the variation in the load (e.g. cyclic loading) very cautious design values for the material properties should be used.

(4)P If one pile load test is carried out, it shall normally be located where the most adverse ground conditions are believed to occur. If this is not possible, an allowance shall be made when deriving the characteristic value of the compressive resistance.

(5)P If load tests are carried out on two or more test piles, the test locations shall be representative of the site of the pile foundation and one of the test piles shall be located where the most adverse ground conditions are believed to occur.

(6)P Between the installation of the test pile and the beginning of the load test, adequate time shall be allowed to ensure that the required strength of the pile material is achieved and the pore-water pressures have regained their initial values.

(7) In some cases it can be necessary to record the pore-water pressures caused by pile installation and their subsequent dissipation in order to take a proper decision regarding the start of the load test.

7.5.2 Static load tests

7.5.2.1 Loading procedure

(1)P The pile load test procedure⁵, particularly with respect to the number of loading steps, the duration of these steps and the application of load cycles, shall be such that conclusions can be drawn about the deformation behaviour, creep and rebound of a piled foundation from the measurements on the pile. For trial piles, the loading shall be such that conclusions can also be drawn about the ultimate failure load.

(2) Devices for the determination of loads, stresses or strains and displacements should be calibrated prior to the test.

(3) The direction of the test load applied to compression or tensile piles should coincide with the longitudinal axis of the pile.

(4) Pile load tests for the purpose of designing a tensile pile foundation should be carried out to failure. Extrapolation of the load-displacement graph for tension tests should not be used.

7.5.2.2 Trial piles

(1)P The number of trial piles required to verify the design shall depend on the following:

- the ground conditions and their variability across the site;
- the Geotechnical Category of the structure, if appropriate;
- previous documented evidence of the performance of the same type of pile in similar ground conditions;
- the total number and types of pile in the foundation design.

(2)P The ground conditions at the test site shall be investigated thoroughly. The depth of borings or field tests shall be sufficient to ascertain the nature of the ground both around and beneath the pile tip. All strata likely to contribute significantly to pile behaviour shall be investigated.

(3)P The method used for the installation of the trial piles shall be fully documented in accordance with 7.9.

7.5.2.3 Working piles

(1)P It shall be specified that the number of working pile load tests shall be selected on the basis of the recorded findings during installation.

(2)P The test load applied to working piles shall be at least equal to the design load for the foundation.

7.5.3 Dynamic load tests

(1) Dynamic load tests⁶ may be used to estimate the compressive resistance provided an adequate site investigation has been carried out and the method has been calibrated against

⁵ See: ISSMFE Subcommittee on Field and Laboratory Testing, Axial Pile Loading Test, Suggested Method. ASTM Journal, June 1985, pp. 79-90.

⁶ See: ASTM Designation D 4945, Standard Test Method for High-Strain Dynamic Testing of Piles.

static load tests on the same type of pile, of similar length and cross-section, and in comparable soil conditions, (see 7.6.2.4 to 7.6.2.6).

(2)P If more than one type of dynamic test is used, the results of different types of dynamic test shall always be considered in relation to each other.

(3) Dynamic load tests may also be used as an indicator of the consistency of the piles and to detect weak piles.

7.5.4 Load test report

(1)P It shall be specified that a factual report shall be written for all load tests. Where appropriate, this report shall include:

- a description of the site;
- the ground conditions with reference to ground investigations;
- the pile type;
- description of the pile installation and of any problems encountered during the works;
- a description of the loading and measuring apparatus and the reaction system;
- calibration documents for the load cells, the jacks and the gauges;
- the installation records of the test piles;
- photographic records of the pile and the test site;
- test results in numerical form;
- time-displacement plots for each applied load when a step loading procedure is used;
- the measured load-displacement behaviour;
- reasons for any departures from the above requirements .

7.6 Axially loaded piles

7.6.1 General

7.6.1.1 Limit state design

(1)P The design shall demonstrate that exceeding the following limit states is sufficiently improbable:

- ultimate limit states of compressive or tensile resistance failure of a single pile;
- ultimate limit states of compressive or tensile resistance failure of the pile foundation as a whole;
- ultimate limit states of collapse or severe damage to a supported structure caused by excessive displacement or differential displacements of the pile foundation;
- serviceability limit states in the supported structure caused by displacement of the piles.

(2) Normally the design should consider the margin of safety with respect to compressive or tensile resistance failure, which is the state in which the pile foundation displaces significantly downwards or upwards with negligible increase or decrease of resistance (see 7.6.2 and 7.6.3).

(3) For piles in compression it is often difficult to define an ultimate limit state from a load settlement plot showing a continuous curvature. In these cases, settlement of the pile top equal to 10% of the pile base diameter should be adopted as the "failure" criterion.

(4)P For piles that undergo significant settlements, ultimate limit states may occur in supported structures before the resistance of the piles is fully mobilised. In these cases a cautious estimate of the possible range of the settlements shall be adopted in design.

NOTE Settlement of piles is considered in 7.6.4

7.6.1.2 Overall stability

(1)P Failure due to loss of overall stability of foundations involving piles in compression shall be considered in accordance with Section 11.

(2) Where there is a possibility of instability, failure surfaces both passing below the piles and intersecting the piles should be considered.

(3)P Failure due to uplift of a block of soil containing piles shall be checked in accordance with 7.6.3.1(4)P.

7.6.2 Compressive ground resistance

7.6.2.1 General

(1)P To demonstrate that the pile foundation will support the design load with adequate safety against compressive failure, the following inequality shall be satisfied for all ultimate limit state load cases and load combinations:

$$F_{c;d} \leq R_{c;d} \quad (7.1)$$

(2) In principle $F_{c;d}$ should include the weight of the pile itself and $R_{c;d}$ should include the overburden pressure of the soil at the foundation base. However these two items may be disregarded if they cancel approximately. They need not cancel if:

- downdrag is significant;
- the soil is very light,
- the pile extends above the surface of the ground.

(3)P For piles in groups, two failure mechanisms shall be taken into account:

- compressive resistance failure of the piles individually;
- compressive resistance failure of the piles and the soil contained between them acting as a block.

The design resistance shall be taken as the lower value caused by these two mechanisms.

- (4) The compressive resistance of the pile group acting as a block may be calculated by treating the block as a single pile of large diameter.
- (5)P The stiffness and strength of the structure connecting the piles in the group shall be considered when deriving the design resistance of the foundation.
- (6) If the piles support a stiff structure, advantage may be taken of the ability of the structure to redistribute load between the piles. A limit state will occur only if a significant number of piles fail together; therefore a failure mode involving only one pile need not be considered.
- (7) If the piles support a flexible structure, it should be assumed that the compressive resistance of the weakest pile governs the occurrence of a limit state.
- (8) Special attention should be given to possible failure of edge piles caused by inclined or eccentric loads from the supported structure.
- (9)P If the layer in which the piles bear overlies a layer of weak soil, the effect of the weak layer on the compressive resistance of the foundation shall be considered.
- (10)P The strength of a zone of ground above and below the pile base shall be taken into account when calculating the pile base resistance.

NOTE This zone may extend several diameters above and below the pile base. Any weak ground in this zone has a relatively large influence on the base resistance.

- (11) Punching failure should be considered if weak ground is present at a depth of less than 4 times the base diameter below the base of the pile.
- (12)P Where the pile base diameter exceeds the shaft diameter, the possible adverse effect shall be considered.
- (13) For open-ended driven tube or box-section piles with openings of more than 500 mm in any direction, and without special devices inside the pile to induce plugging, the base resistance should be limited to the smaller of:

- the shearing resistance between the soil plug and the inside face of the pile;
- the base resistance derived using the A_{AC1} gross cross-sectional A_{AC1} area of the base.

7.6.2.2 Ultimate compressive resistance from static load tests

- (1)P The manner in which load tests are carried out shall be in accordance with 7.5 and shall be specified in the Geotechnical Design Report.
- (2)P Trial piles to be tested in advance shall be installed in the same manner as the piles that will form the foundation and shall be founded in the same stratum.
- (3) If the diameter of the trial pile differs from that of the working piles, the possible difference in performance of piles of different diameters should be considered in assessing the compressive resistance to be adopted.
- (4) In the case of a very large diameter pile, it is often impractical to carry out a load test on a full size trial pile. Load tests on smaller diameter trial piles may be considered provided that:
- the ratio of the trial pile diameter/working pile diameter is not less than 0,5;
 - the smaller diameter trial pile is fabricated and installed in the same way as the piles used for the foundation;

- the trial pile is instrumented in such a manner that the base and shaft resistance can be derived separately from the measurements.

This approach should be used with caution for open-ended driven piles because of the influence of the diameter on the mobilisation of the compressive resistance of a soil plug in the pile.

(5)P In the case of a pile foundation subjected to downdrag, the pile resistance at failure, or at a displacement that equals the criterion for the verification of the ultimate limit state determined from the load test results, shall be corrected. The correction shall be achieved by subtracting the measured, or the most unfavourable, positive shaft resistance in the compressible stratum and in the strata above, where negative skin friction develops, from the loads measured at the pile head.

(6) During the load test of a pile subject to downdrag, positive shaft friction will develop along the total length of the pile and should be considered in accordance with 7.3.2.2(6). The maximum test load applied to the working pile should be in excess of the sum of the design external load plus twice the downdrag force.

(7)P When deriving the ultimate characteristic compressive resistance $R_{c;k}$ from values $R_{c;m}$ measured in one or several pile load tests, an allowance shall be made for the variability of the ground and the variability of the effect of pile installation.

(8)P For structures, which do not exhibit capacity to transfer loads from "weak" piles to "strong" piles, as a minimum, the following equation shall be satisfied:

$$R_{c;k} = \text{Min} \left\{ \frac{(R_{c;m})_{\text{mean}}}{\xi_1}, \frac{(R_{c;m})_{\text{min}}}{\xi_2} \right\} \quad (7.2)$$

where ξ_1 and ξ_2 are correlation factors related to the number of piles tested and are applied to the mean $(R_{c;m})_{\text{mean}}$ and the lowest $(R_{c;m})_{\text{min}}$ of $R_{c;m}$ respectively.

NOTE The values of the correlation factors may be set by the National annex. The recommended values are given in Table A.9.

(9) For structures having sufficient stiffness and strength to transfer loads from "weak" to "strong" piles, the values of ξ_1 and ξ_2 may be divided by 1,1, provided that ξ_1 is never less than 1,0.

(10)P The systematic and random components of the variations in the ground shall be recognised in the interpretation of pile load tests.

(11)P The records of the installation of the test pile(s) shall be checked and any deviation from the normal execution conditions shall be accounted for.

(12) The characteristic compressive resistance of the ground, $R_{c;k}$, may be derived from the characteristic values of the base resistance, $R_{b;k}$, and of the shaft resistance, $R_{s;k}$, such that:

$$R_{c;k} = R_{b;k} + R_{s;k} \quad (7.3)$$

(13) These components may be derived directly from static load test results, or estimated on the basis of ground test results or dynamic load tests.

(14)P The design resistance, $R_{c;d}$, shall be derived from either:

$$R_{c;d} = R_{c;k} / \gamma \quad (7.4)$$

or

$$R_{c;d} = R_{b;k}/\gamma_b + R_{s;k}/\gamma_s \quad (7.5)$$

NOTE The values of the partial factors may be set by the National annex. The recommended values for persistent and transient situations are given in Tables A.6, A.7 and A.8

7.6.2.3 Ultimate compressive resistance from ground test results

(1)P Methods for assessing the compressive resistance of a pile foundation from ground test results shall have been established from pile load tests and from comparable experience as defined in 1.5.2.2.

(2) A model factor may be introduced as described in 2.4.1(9) to ensure that the predicted compressive resistance is sufficiently safe.

(3)P The design compressive resistance of a pile, $R_{c;d}$, shall be derived from:

$$R_{c;d} = R_{b;d} + R_{s;d} \quad (7.6)$$

(4)P For each pile, $R_{b;d}$ and $R_{s;d}$ shall be obtained from:

$$R_{b;d} = R_{b;k}/\gamma_b \text{ and } R_{s;d} = R_{s;k}/\gamma_s \quad (7.7)$$

NOTE The values of the partial factors may be set by the National annex. The recommended values for persistent and transient situations are given in Tables A.6, A.7 and A.8.

(5)P The characteristic values $R_{b;k}$ and $R_{s;k}$ shall either be determined by:

$$R_{c;k} = (R_{b;k} + R_{s;k}) = \frac{R_{b;cal} + R_{s;cal}}{\xi} = \frac{R_{c;cal}}{\xi} = \text{Min} \left\{ \frac{(R_{c;cal})_{\text{mean}}}{\xi_3}; \frac{(R_{c;cal})_{\text{min}}}{\xi_4} \right\} \quad (7.8)$$

where ξ_3 and ξ_4 are correlation factors that depend on the number of profiles of tests, n , and are applied respectively:

— to the mean values $(R_{c;cal})_{\text{mean}} = (R_{b;cal} + R_{s;cal})_{\text{mean}} = (R_{b;cal})_{\text{mean}} + (R_{s;cal})_{\text{mean}}$

— and to the lowest values $(R_{c;cal})_{\text{min}} = (R_{b;cal} + R_{s;cal})_{\text{min}}$,

or by the method given in 7.6.2.3(8).

NOTE The values of the correlation factors may be set by the National annex. The recommended values are given in Table A.10.

(6)P The systematic and random components of the variation in the ground shall be recognised in the interpretation of the ground tests and calculated resistances.

(7) For structures with sufficient stiffness and strength to transfer loads from “weak” to “strong” piles, the factors ξ_3 and ξ_4 may be divided by 1,1, provided that ξ_3 is never less than 1,0.

(8) The characteristic values may be obtained by calculating:

$$R_{b;k} = A_b q_{b;k} \text{ and } R_{s;k} = \sum_i A_{s;i} \cdot q_{s;i;k} \quad (7.9)$$

where $q_{b;k}$ and $q_{s,i;k}$ are characteristic values of base resistance and shaft friction in the various strata, obtained from values of ground parameters.

NOTE If this alternative procedure is applied, the values of the partial factors γ_b and γ_s recommended in Annex A may need to be corrected by a model factor larger than 1,0. The value of the model factor may be set by the National annex.

(9)P If Design Approach 3 is used, the characteristic values of ground parameters shall be determined according to 2.4.5. Partial factors shall then be applied to these characteristic values to obtain design values of the ground parameters for calculating the design values of the pile resistance.

(10) In assessing the validity of a model based on ground test results, the following items should be considered:

- soil type, including grading, mineralogy, angularity, density, pre-consolidation, compressibility and permeability;
- method of installation of the pile, including method of boring or driving;
- length, diameter, material and shape of the shaft and of the base of the pile (e.g. enlarged base);
- method of ground testing.

7.6.2.4 Ultimate compressive resistance from dynamic impact tests

(1)P Where a dynamic impact (hammer blow) pile test [measurement of strain and acceleration versus time during the impact event (see 7.5.3(1))] is used to assess the resistance of individual compression piles, the validity of the result shall have been demonstrated by previous evidence of acceptable performance in static load tests on the same pile type of similar length and cross-section and in similar ground conditions.

(2) When using a dynamic impact load test, the driving resistance of the pile should be measured directly on the site in question.

NOTE A load test of this type can also include a process of signal matching to measured stress wave figures. Signal matching enables an approximate evaluation of shaft and base resistance of the pile as well as a simulation of its load-settlement behaviour.

(3)P The impact energy shall be high enough to allow for an appropriate interpretation of the pile capacity at a correspondingly high enough strain level.

(4)P The design value of the compressive resistance of the pile, $R_{c;d}$ shall be derived from:

$$R_{c;d} = R_{c;k} / \gamma_c \quad (7.10)$$

with

$$R_{c;k} = \text{Min} \left\{ \frac{(R_{c;m})_{\text{mean}}}{\xi_5}; \frac{(R_{c;m})_{\text{min}}}{\xi_6} \right\} \quad (7.11)$$

where ξ_5 and ξ_6 are correlation factors related to the number of piles tested, n , and are applied to the mean $(R_{c;m})_{\text{mean}}$ and the lowest $(R_{c;m})_{\text{min}}$ value of $R_{c;m}$ respectively.

NOTE The values of the partial factor and correlation factors may be set by the National annex. The recommended values are given in Table A.11.

7.6.2.5 Ultimate compressive resistance by applying pile driving formulae

- (1)P Pile driving formulae shall only be used if the stratification of the ground has been determined.
- (2)P If pile driving formulae are used to assess the ultimate compressive resistance of individual piles in a foundation, the validity of the formulae shall have been demonstrated by previous experimental evidence of acceptable performance in static load tests on the same type of pile, of similar length and cross-section, and in similar ground conditions.
- (3)P For end-bearing piles driven into non-cohesive soil, the design value of the compressive resistance, $R_{c;d}$, shall be assessed by the same procedure as in 7.6.2.4.
- (4) When a pile driving formula is applied to verify the compression resistance of a pile, the pile driving test should have been carried out on at least 5 piles distributed at sufficient spacing in the piling area in order to check a suitable blow count for the final series of blows.
- (5) The penetration of the pile point for the final series of blows should be recorded for each pile.

7.6.2.6 Ultimate compressive resistance from wave equation analysis

- (1)P Wave equation analysis shall only be used where stratification of the ground has been determined by borings and field tests.
- (2)P Where wave equation analysis is used to assess the resistance of individual compression piles, the validity of the analysis shall have been demonstrated by previous evidence of acceptable performance in static load tests on the same pile type, of similar length and cross-section, and in similar ground conditions.
- (3)P The design value of the compressive resistance, $R_{c;d}$, derived from the results of wave equation analysis of a number of representative piles, shall be assessed by the same procedure as in 7.6.2.4, using ξ -values based on local experience.

NOTE Wave equation analysis is based on a mathematical model of soil, pile and driving equipment without stress wave measurements on site. The method is usually applied to study hammer performance, dynamic soil parameters and stresses in the pile during driving. It is also, on the basis of the models, possible to determine the required driving resistance (blow count) that is usually related to the expected compressive resistance of the pile.

7.6.2.7 Re-driving

- (1)P In the design, the number of piles to be re-driven shall be specified. If re-driving gives lower results, these shall be used as the basis for ultimate compressive resistance assessment. If re-driving gives higher results, these may be considered.
- (2) Re-driving should usually be carried out in silty soils, unless local comparable experience has shown it to be unnecessary.

NOTE Re-driving of friction piles in clayey soils normally results in reduced compressive resistance.

7.6.3 Ground tensile resistance

7.6.3.1 General

- (1)P The design of piles in tension shall be consistent with the design rules given in 7.6.2, where applicable. Design rules that are specific for foundations involving piles in tension are presented below.

(2)P To verify that the foundation will support the design load with adequate safety against a failure in tension, the following inequality shall be satisfied for all ultimate limit state load cases and load combinations:

$$F_{t,d} \leq R_{t,d} \quad (7.12)$$

(3)P For tension piles, two failure mechanisms shall be considered:

- pull-out of the piles from the ground mass;
- uplift of the block of ground containing the piles.

(4)P Verification against uplift failure of the block of ground containing the piles (see Figure 7.1), shall be carried out in accordance with 2.4.7.4.

(5) For isolated tensile piles or a group of tensile piles, the failure mechanism may be governed by the pull-out resistance of a cone of ground, especially for piles with an enlarged base or rock socket.

(6) When considering the uplift of the block of ground containing the piles the shear resistance T_d along the sides of the block may be added to the resisting forces shown in figure 7.1.

(7) Normally the block effect will govern the design tensile resistance if the distance between the piles is equal to or less than the square root of the product of the pile diameter and the pile penetration into the main resisting stratum.

(8)P The group effect, which may reduce the effective vertical stresses in the soil and hence the shaft resistances of individual piles in the group, shall be considered when assessing the tensile resistance of a group of piles.

(9)P The severe adverse effect of cyclic loading and reversals of load on the tensile resistance shall be considered.

(10) Comparable experience based on pile load tests should be applied to appraise this effect.

7.6.3.2 Ultimate tensile resistance from pile load tests

(1)P Pile load tests to determine the ultimate tensile resistance of an isolated pile, R_t , shall be carried out in accordance with 7.5.1, 7.5.2 and 7.5.4, and with regard to 7.6.2.2.

(2)P The design tensile resistance, $R_{t,d}$, shall be derived from:

$$R_{t,d} = R_{t,k} / \gamma_{s,t} \quad (7.13)$$

NOTE The values of the partial factors may be set by the National annex. The recommended values for persistent and transient situations are given in Tables A.6, A.7 and A.8.

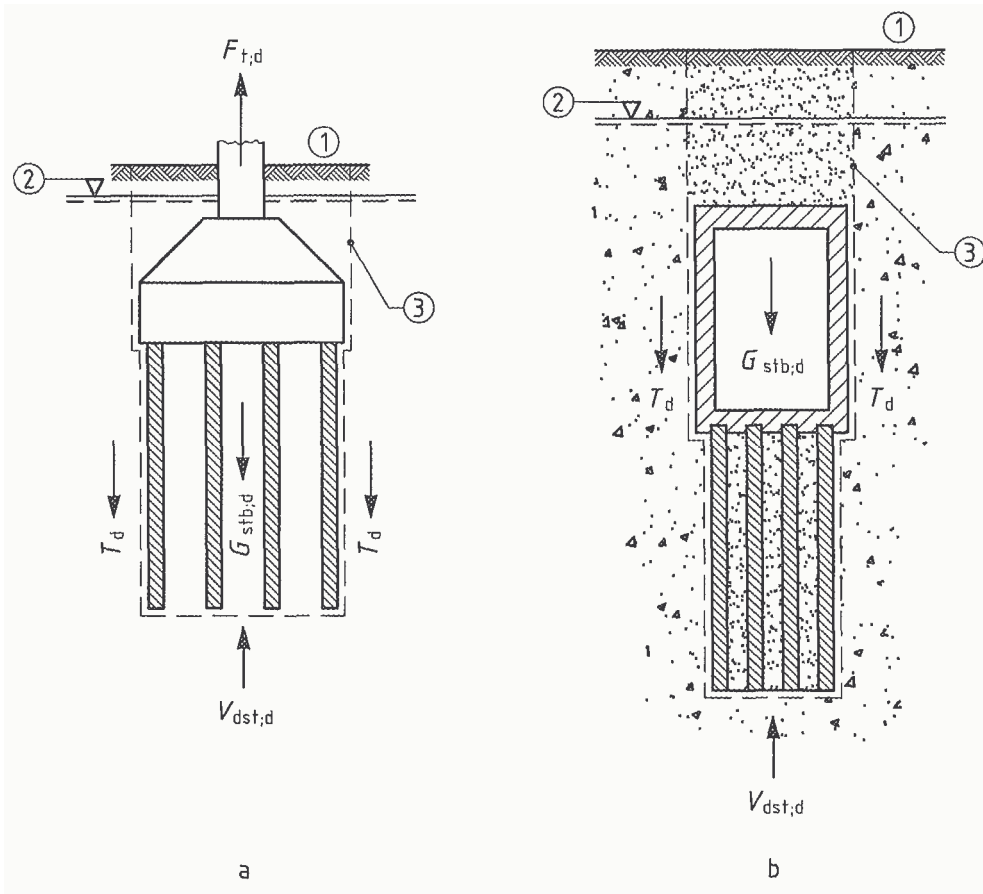

- 1 ground surface
- 2 ground-water level
- 3 side of the 'block', where resistance T_d develops

Figure 7.1 — Examples of uplift (UPL) of a group of piles

(3) Normally when piles are to be loaded in tension, it should be specified that more than one pile should be tested. In the case of a large number of tension piles, at least 2 % should be tested.

(4)P The records of the installation of the test pile(s) shall be checked and any deviation from the normal construction conditions shall be accounted for in the interpretation of the pile load test results.

(5)P The characteristic value of the pile tensile resistance shall be determined by:

$$R_{t,k} = \text{Min} \left\{ \frac{(R_{t,m})_{\text{mean}}}{\xi_1}, \frac{(R_{t,m})_{\text{min}}}{\xi_2} \right\} \quad (7.14)$$

where ξ_1 and ξ_2 are correlation factors related to the number of piles tested, n , and are applied respectively to the mean $(R_{t,m})_{\text{mean}}$ and the lowest $(R_{t,m})_{\text{min}}$ value of the measured tensile resistances.

NOTE The values of the correlation factors may be set by the National annex. The recommended values are given in Table A.9.

7.6.3.3 Ultimate tensile resistance from ground test results

(1)P Methods for assessing the tensile resistance of a pile foundation from ground test results shall have been established from pile load tests and from comparable experience as defined in 1.5.2.2.

(2) A model factor may be introduced as described in 2.4.1(9) to ensure that the predicted tensile resistance is sufficiently safe.

(3)P The design value of tensile resistance of a pile, $R_{t;d}$, shall be derived from:

$$R_{t;d} = R_{t;k} / \gamma_{s,t} \quad (7.15)$$

where:

$$R_{t;k} = R_{s;k} \quad (7.16)$$

NOTE The values of the partial factor may be set by the National annex. The recommended values for persistent and transient situations are given in Tables A.6, A.7 and A.8 .

(4)P The characteristic value $R_{t;k}$ shall either be determined by:

$$R_{t;k} = \text{Min} \left\{ \frac{(R_{s;cal})_{\text{mean}}}{\xi_3}, \frac{(R_{s;cal})_{\text{min}}}{\xi_4} \right\} \quad (7.17)$$

where ξ_3 and ξ_4 are correlation factors that depend on the number of profiles of tests, n , and are applied respectively to the mean $(R_{s;cal})_{\text{mean}}$ and to the lowest value $(R_{s;cal})_{\text{min}}$ of $R_{s;cal}$, or by the method given in 7.6.3.3(6).

NOTE The values of the correlation factors may be set by the National annex. The recommended values are given in Table A.10.

(5)P The systematic and random components of the variation in the ground shall be recognised in the interpretation of the calculated tensile resistance.

(6) The characteristic value of tensile resistance may be obtained by calculating:

$$R_{t;k} = \sum_i A_{s,i} \cdot q_{s;i;k} \quad (7.18)$$

where $q_{s;i;k}$ are characteristic values of shaft friction in the various strata obtained from values of ground properties.

NOTE If this alternative procedure is applied, the value of the partial factor $\gamma_{s,t}$ recommended $\boxed{AC1}$ in $\boxed{AC1}$ Annex A, may need to be corrected by a model factor larger than 1,0. The value of the model factor may be set by the National annex.

(7)P If Design Approach 3 is used, the characteristic values of ground parameters shall be determined according to 2.4.5; partial factors shall then be applied to these characteristic values to obtain design values of the ground parameters to calculate the design values of the pile resistance.

(8) The assessment of the validity of a model based on ground test results should be in accordance with 7.6.2.3(10).

7.6.4 Vertical displacements of pile foundations (Serviceability of supported structure)

7.6.4.1 General

(1)P Vertical displacements under serviceability limit state conditions shall be assessed and checked against the requirements given in 2.4.8 and 2.4.9.

(2) When calculating the vertical displacements of a pile foundation, the uncertainties involved in the calculation model and in determining the relevant ground properties should be taken into account. Hence it should not be overlooked that in most cases calculations will provide only an approximate estimate of the displacements of the pile foundation.

NOTE For piles bearing in medium-to-dense soils and for tension piles, the safety requirements for the ultimate limit state design are normally sufficient to prevent a serviceability limit state in the supported structure.

7.6.4.2 Pile foundations in compression

(1)P The occurrence of a serviceability limit state in the supported structure due to pile settlements shall be checked, taking into account downdrag, where probable.

NOTE When the pile toe is placed in a medium-dense or firm layer overlying rock or very hard soil, the γ_{AC1} partial factors γ_{AC1} for ultimate limit state conditions are normally sufficient to satisfy serviceability limit state conditions.

(2)P Assessment of settlements shall include both the settlement of individual piles and the settlement due to group action.

(3) The settlement analysis should include an estimate of the differential settlements that may occur.

(4) When no load test results are available for an analysis of the interaction of the piled foundation with the superstructure, the load-settlement performance of individual piles should be γ_{AC1} assessed on the basis of γ_{AC1} empirically established safe assumptions.

7.6.4.3 Pile foundations in tension

(1)P The assessment of upward displacements shall be in accordance with the principles of 7.6.4.2.

NOTE Particular attention should be paid to the elongation of the pile material.

(2)P When very severe criteria are set for the serviceability limit state, a separate check of the upward displacements shall be carried out.

7.7 Transversely loaded piles

7.7.1 General

(1)P The design of piles subjected to transverse loading shall be consistent with the design rules given in 7.4 and 7.5, where applicable. Design rules specifically for foundations involving piles subjected to transverse loading are presented below.

(2)P To demonstrate that a pile will support the design transverse load with adequate safety against failure, the following inequality shall be satisfied for all ultimate limit state load cases and load combinations:

$$F_{tr,d} \leq R_{tr,d} \quad (7.19)$$

(3) One of the following failure mechanisms should be considered:

- for short piles, rotation or translation as a rigid body;
- for long slender piles, bending failure of the pile, accompanied by local yielding and displacement of the soil near the top of the pile.

(4)P The group effect shall be considered when assessing the resistance of transversely loaded piles.

(5) It should be considered that a transverse load applied to a group of piles may result in a combination of compression, tension and transverse forces in the individual piles.

7.7.2 Transverse load resistance from pile load tests

(1)P Transverse pile load tests shall be carried out in accordance with 7.5.2.

(2) Contrary to the load test procedure described in 7.5, tests on transversely loaded piles need not normally be continued to a state of failure. The magnitude and line of action of the test load should simulate the design loading of the pile.

(3)P An allowance shall be made for the variability of the ground, particularly over the top few metres of the pile, when choosing the number of piles for testing and when deriving the design transverse resistance from load test results.

(4) Records of the installation of the test pile(s) should be checked, and any deviation from the normal construction conditions should be accounted for in the interpretation of the pile load test results. For pile groups, the effects of interaction and head fixity should be accounted for when deriving the transverse resistance from the results of load tests on individual test piles.

7.7.3 Transverse load resistance from ground test results and pile strength parameters

(1)P The transverse resistance of a pile or pile group shall be calculated using a compatible set of structural effects of actions, ground reactions and displacements.

(2)P The analysis of a transversely loaded pile shall include the possibility of structural failure of the pile in the ground, in accordance with 7.8.

(3) The calculation of the transverse resistance of a long slender pile may be carried out using the theory of a beam loaded at the top and supported by a deformable medium characterised by a horizontal modulus of subgrade reaction.

(4)P The degree of freedom of rotation of the piles at the connection with the structure shall be taken into account when assessing the foundation's transverse resistance.

7.7.4 Transverse displacement

(1)P The assessment of the transverse displacement of a pile foundation shall take into account:

- the stiffness of the ground and its variation with strain level;
- the flexural stiffness of the individual piles;
- the moment fixity of the piles at the connection with the structure;
- the group effect;
- the effect of load reversals or of cyclic loading.

(2) A general analysis of the displacement of a pile foundation should be based on expected degrees of kinematic freedom of movement.

7.8 Structural design of piles

(1)P Piles shall be verified against structural failure in accordance with 2.4.6.4.

(2)P The structure of piles shall be designed to accommodate all the situations to which the piles will be subjected. These include:

- the circumstances of their use e.g. corrosion conditions;
- the circumstances of their installation e.g. adverse ground conditions such as boulders, steeply inclined bedrock surfaces;
- other factors influencing driveability, including quality of joints;
- for precast piles, the circumstances of their transportation to site and installation.

(3)P During structural design, construction tolerances as specified for the type of pile, the action components and the performance of the foundation shall be taken into account.

(4)P Slender piles passing through water or thick deposits of \overline{AC}_1 extremely low strength fine \overline{AC}_1 soil shall be checked against buckling.

(5) Normally a check for buckling is not required when the piles are contained by soils with a \overline{AC}_1 characteristic \overline{AC}_1 shear strength, c_u , that exceeds 10 kPa.

7.9 Supervision of construction

(1)P A pile installation plan shall form the basis for the piling works.

(2) The plan should give the following design information:

- the pile type;
- the location and inclination of each pile, including tolerances on position;
- pile cross-section;
- for cast-in-situ piles, data about the reinforcement;
- pile length;
- pile number;
- required pile load carrying capacity;

- pile toe level (with respect to a fixed datum within or near the site), or the required penetration resistance;
- installation sequence;
- known obstructions;
- any other constraints on piling activities.

(3)P It shall be specified that the installation of all piles is monitored and records are made as the piles are installed.

(4) The record for each pile should include aspects of construction covered in the relevant execution standards, EN 1536:1999, EN 12063:1999, EN 12699:2000, AC1EN 14199:2005, AC1 such as the following:

- pile number;
- installation equipment;
- pile cross-section and length;
- date and time of installation (including interruptions to the installation process);
- concrete mix, volume of concrete used and method of placing for cast-in-situ piles;
- weight density, pH, Marsh viscosity and fines content of bentonite slurry (when used);
- for continuous flight auger piles or other injection piles, volumes and pumping pressures of the grout or concrete, internal and external diameters, pitch of screw and penetration per revolution;
- for displacement piles, the values of driving resistance measurements such as weight and drop or power rating of hammer, blow frequency and number of blows for at least the last 0,25 m penetration;
- the power take-off of vibrators (where used);
- the torque applied to the drilling motor (where used);
- for bored piles, the strata encountered in the borings and the condition of the base if the performance of the pile toe is critical;
- obstructions encountered during piling;
- deviations of position and direction and as-built elevations.

AC1 *Note deleted* AC1

(5) Records should be kept for at least a period of five years after completion of the works. As-built records should be compiled after completion of the piling and kept with the construction documents.

(6)P If site observations or inspection of records reveal uncertainties about the quality of installed piles, investigations shall be carried out to determine their condition and if remedial measures are necessary. These investigations shall include either performing a static pile load or integrity test, installing a new pile or, in the case of a displacement pile, re-driving the pile, in combination with ground tests adjoining the suspect pile.

(7)P Tests shall be used to examine the integrity of piles for which the quality is sensitive to the installation procedures if the procedures cannot be monitored in a reliable way.

(8) Dynamic low strain integrity tests may be used for a global evaluation of piles that might have severe defects or that may have caused a serious loss of strength in the soil during construction. Defects such as insufficient quality of concrete and thickness of concrete cover, both of which can affect the long term performance of a pile, often cannot be found by dynamic tests and other tests, such as sonic tests, vibration tests or coring, may be needed in supervising the execution.

Section 8 Anchors

8.1 General

8.1.1 Scope

(1)P This Section shall apply to the design of temporary and permanent anchors used e.g.:

- to support a retaining structure;
- to ensure the stability of slopes, cuts or tunnels;
- to resist uplift forces on a structure;
- to prevent sliding or tilting;
- to restrain tension cables;

by transmitting a tensile force to a load resisting formation of soil or rock.

(2)P This section shall be used for the design of anchors covered by EN 1537 and other anchors that are consistent with 8.1.2.1, such as screw anchors and expander anchors with a free length.

(3)P Tension members without a free length (such as tension piles) shall be designed using the principles given in Section 7 'Pile foundations'.

(4)P Walls providing fixity for dead-man anchors shall be designed using the principles given in Section 9, 'Retaining structures'.

(5) This section does not cover the design of soil nails or rock bolts.

8.1.2 Definitions

8.1.2.1

anchor

installation capable of transmitting an applied tensile load through a free length to a load bearing stratum

8.1.2.2

grouted anchor

anchor that uses a bonded length formed of cement grout, resin or similar material to transmit the tensile force to the ground

NOTE A 'grouted anchor' in EN 1997-1 is termed a 'ground anchor' in EN 1537.

8.1.2.3

permanent anchor

anchor with a design life which is in excess of two years

8.1.2.4

temporary anchor

anchor with a design life of 2 years or less

8.1.2.5

tendon

part of an anchor that is capable of transmitting the tensile load from the anchor head to the resisting element in the ground

8.1.2.6

anchor fixed length

designed length of an anchor over which the load is transmitted to the surrounding ground A1

A1 8.1.2.7

anchor free length

length of the anchor between the anchorage point at the anchor head and the proximal end of the anchor fixed length

8.1.2.8

tendon bond length for grouted anchors

length of the tendon that is bonded directly to the grout and capable of transmitting the applied tensile load

8.1.2.9

tendon free length

length of the tendon between the anchorage point at the anchor head and the proximal end of the tendon bond length

8.1.2.10

apparent tendon free length

length of tendon which is estimated to be fully decoupled from the surrounding grout and is calculated from the load-elastic displacement data following testing

8.1.2.11

investigation test

load test to establish the geotechnical ultimate resistance of an anchor and to determine the characteristics of the anchor in the working load range

8.1.2.12

suitability test

load test to confirm that a particular anchor design will be adequate in particular ground conditions

8.1.2.13

acceptance test

load test to confirm that an individual anchor conforms with its acceptance criteria

8.2 Limit states

(1)P The following limit states (both individually and in combination) shall be considered for all anchors:

- structural failure of the tendon or anchor head, caused by the applied stresses;
- failure of the connection between the tendon and the resisting element in the ground;
- loss of anchor force and excessive displacements of the anchor head due to creep and relaxation;
- failure or excessive deformation of parts of the anchored structure due to the applied anchor force;
- loss of overall stability of the retained ground and the retaining structure (see Section 11);
- limit states in supported or adjacent structures, including those arising from pre-stressing forces;
- instability or excessive deformation of the zone of ground into which tensile forces from a group of anchors are to be transferred;
- failure at the interface between the resisting element and the ground.

(2)P In addition to the limit states listed in 8.2(1)P, the following limit states (both individually and in combination) shall be considered for all grouted anchors:

- failure at the interface between the body of grout and the ground;
- failure of the bond at the interfaces of tendon, encapsulation and grout;
- failure of the bond between the tendon and the grout. **A1**

Ⓐ (3) For a group of anchors, the most critical failure surface should be considered.

NOTE Depending on spacing and the profile of ground strength, this can involve displacement of part or all of the block contained by the anchors, often combined with pull-out of the distal ends of the anchors.

8.3 Design situations and actions

(1)P Design situations shall be selected in accordance with 2.2.

(2)P In addition, consideration shall be given to:

- all pertinent limit states listed in 8.2 and their combinations;
- chemical components of ground or groundwater that can adversely affect the durability of the anchor.

(3)P The design value of the anchor load shall be derived from the design of the anchored structure, taking into consideration ultimate and serviceability limit states.

8.4 Design and construction considerations

(1)P Anchors shall not be used unless their design and construction have been verified by investigation or suitability tests in accordance with EN ISO 22477-5 or by comparable experience (as defined in 1.5.2.2) and have been shown to have the required performance and durability, which have been documented.

(2)P Account shall be taken of the effects of any deformations imposed on adjacent structures when installing the anchor and by the anchor pre-stress force.

(3) The zone of ground into which tensile forces are to be transferred should be included in site investigations whenever possible.

(4)P For pre-stressed anchors, the anchor head shall be designed to allow the tendon to be stressed, proof-loaded and locked-off and, if required, released, de-stressed and re-stressed.

(5)P The anchor head shall be designed to tolerate angular deviations of the anchor force, and to be able to accommodate deformations that can occur during the design life of the structure.

(6)P Since the effectiveness of an anchor depends on its free length, the anchor force shall act in ground that is sufficiently distant from the anchored structure such that no additional force is applied on it. The necessary anchor free length shall be determined in the design of the anchored structure.

NOTE The method of determining the necessary free length may be set in the National Annex.

(7)P Measures shall be taken to avoid adverse interactions between anchors that are located close to each other.

NOTE The criteria for the necessity to check the group effects may be set in the National Annex.

(8)P The direction of the anchor should normally be chosen to enable self-stressing under deformation. If this is not feasible, the adverse effects of potential failure mechanisms shall be taken into account.

(9)P A sufficient lock-off force shall be used to ensure that the anchor resistance under serviceability limit state conditions will be mobilised with tolerable head displacements.

(10) If the anchor is analysed as a spring, its stiffness should be selected to achieve compatibility between calculated displacements of the retained structure and the displacement and elongation of the anchor, including displacement of the fixed anchor length. Ⓐ

A1 (11)P Corrosion protection of anchors that have a tendon made of steel shall be designed taking into account the type of steel and the aggressiveness of the ground environment.

(12)P For grouted anchors, corrosion protection shall be in accordance with EN 1537.

8.5 Limit state design of anchors

8.5.1 General

(1)P The design value of the geotechnical ultimate limit state resistance of an anchor, $R_{\text{ULS};d}$, shall satisfy the following inequality:

$$E_{\text{ULS};d} \leq R_{\text{ULS};d} \quad (8.1)$$

where:

$$E_{\text{ULS};d} = \max(F_{\text{ULS};d}; F_{\text{Serv};d}) \quad (8.2)$$

and where:

$$F_{\text{Serv};d} = \gamma_{\text{Serv}} \times F_{\text{Serv};k} \quad (8.3)$$

NOTE 1 The value of partial factor γ_{Serv} may be set by the National Annex. The recommended value for persistent and transient situations is given in Table A.18.

NOTE 2 Formulae (8.1) to (8.3) are also applicable to uplift calculations (UPL).

NOTE 3 It is assumed in Section 8 that all partial factors and correlations factors for serviceability limit states are unity unless symbols are specifically included. The values for additional partial factors and correlation factors for serviceability limit states may be set in the National Annex.

(2)P When a separate evaluation of the serviceability limit state of the anchor is required the evaluation shall be carried out using Formula (8.4).

$$F_{\text{Serv};k} \leq R_{\text{SLS};d} \quad (8.4)$$

NOTE 1 The National Annex may set whether a separate evaluation of the serviceability limit state of the anchor is required.

NOTE 2 The National Annex may set whether the verifications for ultimate limit state and serviceability limit state are to be carried out separately or in a combined procedure.

8.5.2 Geotechnical ultimate limit state resistance

(1)P The measured geotechnical ultimate limit state resistance of an anchor as defined in 8.5.2(2)P shall be determined from a number of investigation or suitability tests (n) carried out in accordance with EN ISO 22477-5.

NOTE The test method to be used to determine the measured resistance and the number of tests n may be set in the National Annex.

(2)P The measured ultimate limit state resistance of an anchor $R_{\text{ULS};m}$ shall be determined by load tests as the lesser of the proof load or the load causing a limiting condition (R_m). The limiting condition depends on the test method and may be: **A1**

- A1** — the asymptote to the creep rate versus load curve, or;
- the load corresponding to a limit value of the creep rate (α_{ULS}), or;
 - the load corresponding to a limit value of load loss ($k_{\text{i,ULS}}$).

Thus:

$$R_{\text{ULS};m} = \min \left\{ R_m \left(\alpha_{\text{ULS}} \text{ or } k_{\text{i,ULS}} \right) \text{ and } P_p \right\} \quad (8.5)$$

NOTE The limit value of the creep rate (α_{ULS}) or load loss ($k_{\text{i,ULS}}$) may be set by the National Annex, which may specify the use of an asymptote to the creep rate versus load curve in place of a specified value for α_{ULS} . Recommended values for persistent and transient situations are given in Table A.21.

(3)P The characteristic value of the ultimate limit state geotechnical resistance of an anchor, $R_{\text{ULS};k}$, shall be derived from:

$$R_{\text{ULS};k} = \frac{(R_{\text{ULS};m})_{\min}}{\xi_{\text{ULS}}} \quad (8.6)$$

NOTE 1 Values of the correlation factor ξ_{ULS} may be set by the National Annex. Recommended values for persistent and transient situations are given in Table A.20.

NOTE 2 The minimum number of investigation and suitability tests n to be carried out to determine $(R_{\text{ULS};m})_{\min}$ may be set by the National Annex. Recommended values for persistent and transient situations are given in Table A.20.

(4) Investigation tests should normally be loaded to the estimated ultimate resistance of the ground/grout interface and may require tendons and other structural components of greater capacity than used in suitability or acceptance tests.

(5)P The design value of the geotechnical ultimate limit state resistance of an anchor shall be derived from:

$$R_{\text{ULS};d} = \frac{R_{\text{ULS};k}}{\gamma_{\text{a,ULS}}} \quad (8.7)$$

NOTE The value of the partial factor $\gamma_{\text{a,ULS}}$ may be set by the National Annex. Recommended values for persistent and transient situations are given in Table A.19.

8.5.3 Geotechnical serviceability limit state resistance

(1)P The measured geotechnical serviceability limit state resistance of an anchor as defined in 8.5.3(2)P shall be determined from a number of investigation and/or suitability tests (n) carried out in accordance with EN ISO 22477-5.

NOTE 1 The test method to be used to determine the measured resistance and the number of test n may be set in the National Annex.

NOTE 2 The test method to be used to determine the measured resistance may be set in the National Annex

(2)P The measured geotechnical serviceability limit state of a test anchor $R_{\text{SLS};m}$ shall be determined by investigation tests or suitability tests as the lesser of the proof load or the load causing a limiting condition. The limiting condition depends on the test method and is the critical creep load (P_C) or the load corresponding to a limit value of the creep rate (α_{SLS}) or load loss ($k_{\text{i,SLS}}$). Thus: **A1**

$$\boxed{A_1} R_{SLS;m} = \min \left\{ R_m \left(\alpha_{SLS} \text{ or } k_{i,SLS} \text{ or } P_c \right) \text{ and } P_p \right\} \quad (8.8)$$

NOTE The limit value of the creep rate (α_{SLS}) or load loss ($k_{i,SLS}$) or P_c may be set by the National Annex. Recommended values are given in Table A.21.

(3)P The characteristic value of the serviceability anchor resistance ($R_{SLS;k}$) shall be derived from:

$$R_{SLS;k} = (R_{SLS;m})_{\min} \quad (8.9)$$

NOTE The minimum number of investigation and suitability tests n to be carried out to determine $(R_{SLS;m})_{\min}$ may be set by the National Annex. Recommended values are given in Table A.20.

(4)P The design value of the serviceability limit state anchor resistance shall be derived from:

$$R_{SLS;d} = \frac{R_{SLS;k}}{\gamma_{a,SLS}} \quad (8.10)$$

NOTE The value of the partial factor $\gamma_{a,SLS}$ may be set by the National Annex. The recommended values are given in Table A.20.

8.5.4 Structural resistance

(1)P The ultimate limit state design resistance of the structural elements of an anchor, $R_{t,d}$, shall be calculated according to the structural Eurocodes, e.g. EN 1992 and EN 1993 as relevant, to satisfy the inequality:

$$E_{ULS;d} \leq R_{t,d} \quad (8.11)$$

(2)P The structural design of an anchor under a proof load shall comply with 5.10.2.1 from EN 1992-1-1:2004.

(3) For grouted anchors, the tendon/grout resistance of the anchor shall comply with the relevant standards, for example EN 1992-1-1 and EN 1537.

NOTE ETAG 013 *Guideline for European Technical Approval of post-tensioning kits for prestressing of structures*, Eota, Brussels, edition: June 2002, may be applicable.

8.6 Tests on anchors

8.6.1 Investigation or suitability tests

(1)P In order to satisfy the requirements of 8.5.1, investigation or suitability tests carried out in accordance with EN ISO 22477-5 shall be undertaken to verify that limiting criteria are not exceeded at a proof load, P_p , given by:

$$P_p \geq \xi_{ULS} \times \gamma_{a,ULS} \times E_{ULS;d} \quad (8.12)$$

(2) Grouted anchors with tendon bond lengths spaced at less than 1,5 m should be tested in groups unless comparable experience has shown that the interaction has quantifiable effects which can be taken into account.

8.6.2 Acceptance tests

(1)P Acceptance tests shall be carried out in accordance with EN ISO 22477-5 on all grouted anchors prior to their lock off and before they become operational. $\boxed{A_1}$

A1 (2)P The proof load, P_P , to be applied to the anchor in an acceptance test shall be derived from the ultimate limit state design force $E_{ULS;d}$ or from $F_{Serv;k}$ using the following inequalities:

$$P_P \geq \gamma_{a,acc;ULS} \times E_{ULS;d} \quad (8.13)$$

or:

$$P_P \geq \gamma_{a,acc;SLS} \times F_{Serv;k} \quad (8.14)$$

NOTE 1 The value of the partial factors $\gamma_{a,acc;ULS}$ and $\gamma_{a,acc;SLS}$ may be set by the National Annex. Recommended values for $\gamma_{a,acc;ULS}$ for persistent and transient situations and for $\gamma_{a,acc;SLS}$ are given in Table A.20.

NOTE 2 The National Annex may state whether the proof load in an acceptance test is to be related to the ultimate limit state design force (8.13) or to $F_{Serv;k}$ (8.14).

(3)P For each test, the creep rate/load loss that occurs under the proof load and under other specified loads shall not exceed limiting values.

NOTE 1 The limiting values for creep rate/load loss at proof load may be set by the National Annex. Recommended values for persistent and transient situations are given in Table A.21.

NOTE 2 The requirement to check creep rate/load loss at other specified loads, less than the proof load, is optional and may be set by the National Annex. No recommended values are provided.

(4)P The apparent free length of a grouted anchor shall comply with the requirements in EN 1537.

8.7 Lock-off load for pre-stressed anchors

(1)P The lock-off load shall be sufficient to ensure serviceability of the structure and supporting structures.

(2)P The lock-off load shall not give rise to a limit state in the ground, in the structure or in supporting structures.

(3) For grouted anchors, where tendon bond lengths of a group of anchors cross at spacings less than 1,5 m (centre to centre), the pre-stress should be checked on selected anchors after completion of the lock-off process.

8.8 Supervision, monitoring and maintenance

(1) Supervision, monitoring and maintenance should follow the rules given in Section 4 of this standard and in EN 1537, where appropriate. **A1**

Section 9 Retaining structures

9.1 General

9.1.1 Scope

(1)P The provisions of this Section shall apply to structures, which retain ground comprising soil, rock or backfill and water. Material is retained if it is kept at a slope steeper than it would eventually adopt if no structure were present. Retaining structures include all types of wall and support systems in which structural elements have forces imposed by the retained material.

(2)P Pressure from granular material stored in silos shall be calculated using EN 1991-4.

9.1.2 Definitions

(1) In considering the design of retaining structures the following three main types should be distinguished:

9.1.2.1

gravity walls

walls of stone or plain or reinforced concrete having a base footing with or without a heel, ledge or buttress. The weight of the wall itself, sometimes including stabilising masses of soil, rock or backfill, plays a significant role in the support of the retained material. Examples of such walls include concrete gravity walls having constant or variable thickness, spread footing reinforced concrete walls and buttress walls.

9.1.2.2

embedded walls

relatively thin walls of steel, reinforced concrete or timber, supported by A_1 anchors A_1 , struts and/or passive earth pressure. The bending capacity of such walls plays a significant role in the support of the retained material while the role of the weight of the wall is insignificant. Examples of such walls include cantilever steel sheet pile walls, anchored or strutted steel or concrete sheet pile walls and diaphragm walls.

9.1.2.3

composite retaining structures

walls composed of elements from the above two types of wall. A large variety of such walls exists and examples include double sheet pile wall cofferdams, earth structures reinforced by tendons, geotextiles or grouting and structures with multiple rows of ground A_1 anchors A_1 or soil nails.

9.2 Limit states

(1)P A list shall be compiled of limit states to be considered. As a minimum the following limit states shall be considered for all types of retaining structure:

- loss of overall stability;
- failure of a structural element such as a wall, A_1 anchor A_1 , wale or strut or failure of the connection between such elements;
- combined failure in the ground and in the structural element;
- failure by hydraulic heave and piping;

- movement of the retaining structure, which may cause collapse or affect the appearance or efficient use of the structure or nearby structures or services, which rely on it;
- unacceptable leakage through or beneath the wall;
- unacceptable transport of soil particles through or beneath the wall;
- unacceptable change in the ground-water regime.

(2)P In addition, the following limit states shall be considered for gravity walls and for composite retaining structures:

- bearing resistance failure of the soil below the base;
- failure by sliding at the base;
- failure by toppling;

and for embedded walls:

- failure by rotation or translation of the wall or parts thereof;
- failure by lack of vertical equilibrium.

(3)P For all types of retaining structure, combinations of the above mentioned limit states shall be taken into account, if relevant.

(4) Design of gravity walls often requires solution of the same types of problem encountered in the design of spread foundations and embankments and slopes. When considering the limit states, the principles of Section 6 should therefore be applied, as appropriate. Special care should be taken to account for bearing resistance failure of the ground below the base of the wall under loads with large eccentricities and inclinations (see 6.5.4).

9.3 Actions, geometrical data and design situations

9.3.1 Actions

9.3.1.1 Basic actions

(1) The actions listed in 2.4.2(4) should be considered.

9.3.1.2 Weight of backfill material

(1)P Design values for the weight density of backfill material shall be estimated from knowledge of available material. The Geotechnical Design Report shall specify the checks, which shall be made during the construction process to verify that the actual field values are no worse than those used in the design.

9.3.1.3 Surcharges

(1)P Determination of design values for surcharges shall take account of the presence, on or near the surface of the retained ground, of, for example, nearby buildings, parked or moving vehicles or cranes, stored material, goods and containers.

(2) Care should be taken in the case of repeated surcharge loading such as imposed by crane rails on a quay wall. The pressures induced by such surcharges can significantly exceed those due to the first loading or those resulting from static application of a load of equal magnitude.

9.3.1.4 Weight of water

(1)P Design values for the weight density of water shall reflect whether the water is fresh, saline or charged with chemicals or contaminants to an extent that the normal value needs amendment.

9.3.1.5 Wave and ice forces

(1)P Design values for forces imposed by reflected waves or by ice ~~text deleted~~ shall be selected on the basis of locally available data for the climatic and hydraulic conditions at the site.

(2)P When selecting design values for static forces imposed by a sheet of ice, the following shall be taken into account:

- the initial temperature of the ice before warming begins;
- the rate at which the temperature increases;
- the thickness of the ice sheet.

9.3.1.6 Seepage forces

(1)P Seepage forces due to different ground-water levels behind and in front of a retaining structure shall be considered as they may change the earth pressure behind the wall and reduce the earth resistance in front of the wall.

9.3.1.7 Collision forces

(1)The determination of design values for collision impact forces, caused by, for example, waves, ice floes or traffic, may take account of the energy absorbed by the colliding mass and by the retaining system, e.g. by fenders and/or guide structures.

(2) For lateral impacts on retaining walls, the increased stiffness exhibited by the retained ground should be considered.

(3) The risk of the occurrence of liquefaction due to lateral impact on embedded walls should be investigated.

(4)P The impact load of an ice floe colliding with a retaining structure shall be calculated on the basis of the compressive strength of the ice and the thickness of the ice floe. The salinity and homogeneity of the ice shall be considered in calculating the compressive strength.

9.3.1.8 Temperature effects

(1)P The design of retaining structures shall take into account the temporal and spatial effects of abnormal temperature changes.

(2) These effects should be considered particularly when determining the loads in struts and props.

(3) The Structural Fire Design Parts of the material related Eurocodes should be consulted when dealing with the effects of fire.

(4)P Special precautions, such as selection of suitable backfill material, drainage or insulation, shall be taken to prevent ice lenses forming in the ground behind retaining structures.

9.3.2 Geometrical data

9.3.2.1 Basic data

(1)P Design values for geometrical data shall be derived in accordance with the principles stated in 2.4.6.3.

9.3.2.2 Ground surfaces

(1)P Design values for the geometry of the retained material shall take account of the variation in the actual field values. The design values shall also take account of anticipated excavation or possible scour in front of the retaining structure.

(2) In ultimate limit state calculations in which the stability of a retaining wall depends on the ground resistance in front of the structure, the level of the resisting soil should be lowered below the nominally expected level by an amount Δa . The value of Δa should be selected taking into account the degree of site control over the level of the surface. With a normal degree of control, the following should be applied:

- for a cantilever wall, Δa should equal 10 % of the wall height above excavation level, limited to a maximum of 0,5 m;
- for a supported wall, Δa should equal 10 % of the distance between the lowest support and the excavation level, limited to a maximum of 0,5 m.

(3) Smaller values of Δa , including 0, may be used when the surface level is specified to be controlled reliably throughout the appropriate $\boxed{AC_1}$ design situation $\boxed{AC_1}$.

(4) Larger values of Δa should be used where the surface level is particularly uncertain.

9.3.2.3 Water levels

(1)P The selection of design or characteristic values for the positions of free water and phreatic surfaces shall be made on the basis of data for the hydraulic and hydrogeological conditions at the site.

(2)P Account shall be taken of the effects of variation in permeability on the ground-water regime.

(3)P The possibility shall be considered of adverse water pressures due to the presence of perched or artesian water tables.

9.3.3 Design situations

(1)P The following items shall be considered:

- variations in soil properties, water levels and pore-water pressures in space;
- anticipated variations in soil properties, water levels and pore-water pressures in time;
- variation in actions and in the ways they are combined;
- excavation, scour or erosion in front of the retaining structure;
- the effects of compaction of the backfilling behind the retaining structure;

- the effects of anticipated future structures and surcharge loadings or unloadings on or close to the retained material;
 - anticipated ground movements due, for example, to subsidence or frost action.
- (2) For waterfront structures, ice and wave forces need not be applied simultaneously at the same point.

9.4 Design and construction considerations

9.4.1 General

(1)P Both ultimate and serviceability limit states shall be considered using the procedures described in 2.4.7 and 2.4.8.

(2)P It shall be demonstrated that vertical equilibrium can be achieved for the assumed pressure distributions and actions on the wall.

(3) The verification of vertical equilibrium may be achieved by reducing the wall friction parameters.

(4) As far as possible, retaining walls should be designed in such a way that there are visible signs of the approach of an ultimate limit state. The design should guard against the occurrence of brittle failure, e.g. sudden collapse without conspicuous preliminary deformations.

(5) For many earth retaining structures, a critical limit state should be considered to occur if the wall has displaced enough to cause damage to nearby structures or services. Although collapse of the wall may not be imminent, the degree of damage may considerably exceed a serviceability limit state in the supported structure.

(6) The design methods and partial factor values recommended by this standard are usually sufficient to prevent the occurrence of ultimate limit states in nearby structures, provided that the soils involved are of at least medium density or firm consistency and that adequate construction methods and sequences are adopted. Special care should be taken, however, with some highly over-consolidated clay deposits in which large at rest horizontal stresses may induce substantial movements in a wide area around excavations.

(7) The complexity of the interaction between the ground and the retaining structure sometimes makes it difficult to design a retaining structure in detail before the actual execution begins. In this case use of the observational method for the design (see 2.7) should be considered.

(8)P The design of retaining structures shall take account of the following items, where appropriate:

- the effects of constructing the wall, including:
 - the provision of temporary support to the sides of excavations;
 - the changes of in situ stresses and resulting ground movements caused both by the wall excavation and its construction;
 - disturbance of the ground due to driving or boring operations;
 - provision of access for construction;
- the required degree of water tightness of the finished wall;

- the practicability of constructing the wall to reach a stratum of low permeability, so forming a water cut-off. The resulting equilibrium ground-water flow problem shall be assessed;
- the practicability of forming ground A_1 anchors A_1 in adjacent ground;
- the practicability of excavating between any propping of retaining walls;
- the ability of the wall to carry vertical load;
- the ductility of structural components;
- access for maintenance of the wall and any associated drainage measures;
- the appearance and durability of the wall and any A_1 anchors A_1 ;
- for sheet piling, the need for a section stiff enough to be driven to the design penetration without loss of interlock;
- the stability of borings or slurry trench panels while they are open;
- for fill, the nature of materials available and the means used to compact them adjacent to the wall, in accordance with 5.3.

9.4.2 Drainage systems

(1)P If the safety and serviceability of the designed structure depend on the successful performance of a drainage system, the consequences of its failure shall be considered, having regard for both safety and cost of repair. One of the following conditions (or a combination of them) shall apply:

- a maintenance programme for the drainage system shall be specified and the design shall allow access for this purpose;
- it shall be demonstrated both by comparable experience and by assessment of any water discharge, that the drainage system will operate adequately without maintenance.

(2) The quantities, pressures and eventual chemical content of any water discharge should be taken into account.

9.5 Determination of earth pressures

9.5.1 General

(1)P Determination of earth pressures shall take account of the acceptable mode and amount of any movement and strain, which may occur at the limit state under consideration.

(2) In the following context the words "earth pressure" should also be used for the total earth pressure from soft and weathered rocks and should include the pressure of ground-water.

(3)P Calculations of the magnitudes of earth pressures and directions of forces resulting from them shall take account of:

- the surcharge on and slope of the ground surface;
- the inclination of the wall to the vertical;
- the water tables and the seepage forces in the ground;

- the amount and direction of the movement of the wall relative to the ground;
 - the horizontal as well as vertical equilibrium for the entire retaining structure;
 - the shear strength and weight density of the ground;
 - the rigidity of the wall and the supporting system;
 - the wall roughness.
- (4) The amount of mobilised wall friction and adhesion should be considered as a function of:
- the strength parameters of the ground;
 - the friction properties of the wall-ground interface;
 - the direction and amount of movement of the wall relative to the ground;
 - the ability of the wall to support any vertical forces resulting from wall friction and adhesion.
- (5) The amount of shear stress, which can be mobilised at the wall-ground interface should be determined by the wall-ground interface parameter δ .
- (6) A concrete wall or steel sheet pile wall supporting sand or gravel may be assumed to have a design wall ground interface parameter $\delta_d = k \cdot \varphi_{cv;d}$. k should not exceed 2/3 for precast concrete or steel sheet piling.
- (7) For concrete cast against soil, a value of $k = 1,0$ may be assumed.
- (8) For a steel sheet pile in clay under undrained conditions immediately after driving, no adhesive or frictional resistance should be assumed. Increases in these values may take place over a period of time.
- (9)P The magnitudes of earth pressures and directions of resultant forces shall be calculated according to the selected design approach (see 2.4.7.3), and the limit state being considered.
- (10) The value of an earth pressure at an ultimate limit state is generally different from its value at a serviceability limit state. These two values are determined from two fundamentally different calculations. Consequently, when expressed as an action, earth pressure cannot have a single characteristic value.
- (11)P In the case of structures retaining rock masses, calculations of the ground pressures shall take account of the effects of discontinuities, with particular attention to their orientation, spacing, aperture, roughness and the mechanical characteristics of any joint filling material.
- (12)P Account shall be taken of any swelling potential of the ground when calculating the pressures on the retaining structure.

9.5.2 At rest values of earth pressure

- (1)P When no movement of the wall relative to the ground takes place, the earth pressure shall be calculated from the at rest state of stress. The determination of the at rest state shall take account of the stress history of the ground.
- (2) For normally consolidated soil, at rest conditions should normally be assumed in the ground behind a retaining structure if the movement of the structure is less than $5 \times 10^{-4} \times h$.

(3) For a horizontal ground surface, the at rest earth pressure coefficient, K_0 , should be determined from:

$$K_0 = (1 - \sin \phi') \times \sqrt{\text{OCR}} \quad (9.1)$$

The formula should not be used for very high values of OCR.

(4) If the ground slopes upwards from the wall at an angle $\beta \leq \phi'$ to the horizontal, the horizontal component of the effective earth pressure $\sigma'_{h,0}$ may be related to the effective overburden pressure q' by the ratio $K_{0,\beta}$, where

$$K_{0,\beta} = K_0 \cdot (1 + \sin \beta) \quad (9.2)$$

The direction of the resulting force should then be assumed to be parallel to the ground surface.

9.5.3 Limiting values of earth pressure

(1)P Limiting values of earth pressures shall be determined taking account of the relative movement of the soil and the wall at failure and the corresponding shape of the failure surface.

(2) Limiting values of earth pressure assuming straight failure surfaces can significantly deviate from the values assuming curved failure surfaces for α_{AC1} high angles of shearing resistance α_{AC1} and wall-ground interface parameters δ , and so lead to unsafe results.

NOTE Annex C provides some data of relative movements that cause limiting values of earth pressures.

(3) In cases where struts, α_{A1} anchors α_{A1} or similar elements impose restraints on movement of the retaining structure, it should be considered that the limiting active and passive values of earth pressure, and their distributions, may not be the most adverse ones.

9.5.4 Intermediate values of earth pressure

(1)P Intermediate values of earth pressure occur if the wall movements are insufficient to mobilise the limiting values. The determination of the intermediate values of earth pressure shall take account of the amount of wall movement and its direction relative to the ground.

NOTE Annex C, figure C.3, gives a diagram, which may be used for the determination of the mobilised passive earth pressure

(2) The intermediate values of earth pressures may be calculated using, for example, various empirical rules, spring constant methods or finite element methods.

9.5.5 Compaction effects

(1)P The determination of earth pressures acting behind the wall shall take account of the additional pressures generated by any placing of backfill and the procedures adopted for its compaction.

NOTE Measurements indicate that the additional pressures depend on the applied compactive energy, the thickness of the compacted layers and the travel pattern of the compaction plant. Horizontal pressure normal to the wall in a layer may reduce when the next layer is placed and compacted. When backfilling is complete, the additional pressure normally acts only on the upper part of the wall.

(2)P Appropriate compaction procedures shall be specified with the aim of avoiding excessive additional earth pressures, which may lead to unacceptable movements.

9.6 Water pressures

(1)P Determination of characteristic and design water pressures shall take account of water levels both above and in the ground.

(2)P When checking the ultimate and serviceability limit states, water pressures shall be accounted for in the combinations of actions in accordance with 2.4.5.3 and 2.4.6.1, considering the possible risks indicated in 9.4.1(5).

$\overline{AC_1}$ (3) $\overline{AC_1}$ For structures retaining earth of medium or low permeability (silts and clays), water pressures $\overline{AC_1}$ should normally $\overline{AC_1}$ be assumed to act behind the wall. Unless a reliable drainage system is installed (9.4.2(1)P), or infiltration is prevented, the values of water pressures $\overline{AC_1}$ should normally $\overline{AC_1}$ correspond to a water table at the surface of the retained material.

(4)P Where sudden changes in a free water level may occur, both the non-steady condition occurring immediately after the change and the steady condition shall be examined.

(5)P Where no special drainage or flow prevention measures are taken, the possible effects of water-filled tension or shrinkage cracks shall be considered.

9.7 Ultimate limit state design

9.7.1 General

(1)P The design of retaining structures shall be checked at the ultimate limit state for the design situations appropriate to that state, as specified in 9.3.3, using the design actions or action effects and design resistances.

(2)P All relevant limit modes shall be considered. These will include, as a minimum, limit modes of the types illustrated in figures 9.1 to 9.6 for the most commonly used retaining structures.

(3)P Calculations for ultimate limit states shall establish that equilibrium can be achieved using the design actions or effects of actions and the design strengths or resistances, as specified in clause 2.4. Compatibility of deformations shall be considered in assessing design strengths or resistances.

(4)P Upper or lower design values, whichever are more adverse, shall be used for the strength or resistance of the ground.

(5) Calculation methods may be used, which redistribute earth pressure in accordance with the relative displacements and stiffnesses of ground and structural elements.

(6)P For fine grained soils, both short- and long-term behaviour shall be considered.

(7)P For walls subject to differential water pressures, safety against failure due to hydraulic heave and piping shall be checked.

9.7.2 Overall stability

(1)P The principles in Section 11 shall be used as appropriate to demonstrate that an overall stability failure will not occur and that the corresponding deformations are sufficiently small.

(2) As a minimum, limit modes of the types illustrated in figure 9.1 should be considered, taking progressive failure and liquefaction into account as relevant.

9.7.3 Foundation failure of gravity walls

(1)P The principles of Section 6 shall be used as appropriate to demonstrate that a foundation failure is sufficiently remote and that deformations will be acceptable. Both bearing resistance and sliding shall be considered.

(2) As a minimum, limit modes of the types illustrated in Figure 9.2 should be considered.

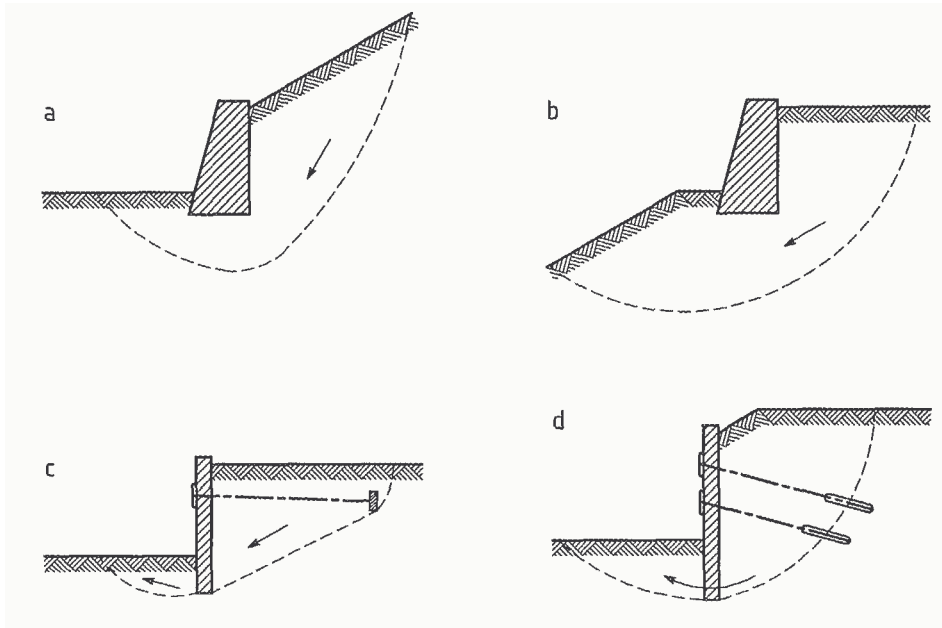

Figure 9.1 — Examples of limit modes for overall stability of retaining structures.

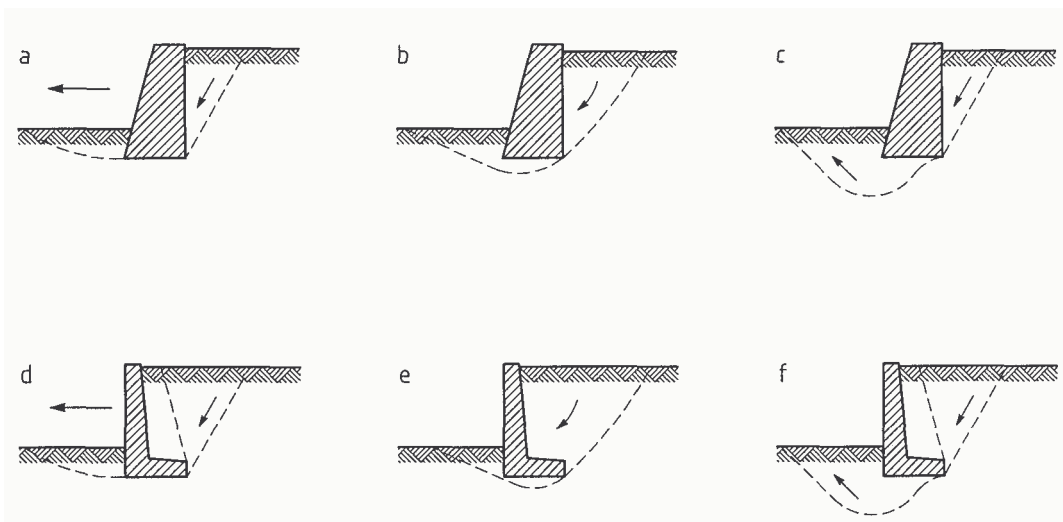

Figure 9.2 — Examples of limit modes for foundation failures of gravity walls

9.7.4 Rotational failure of embedded walls

(1)P It shall be demonstrated by equilibrium calculations that embedded walls have sufficient penetration into the ground to prevent rotational failure.

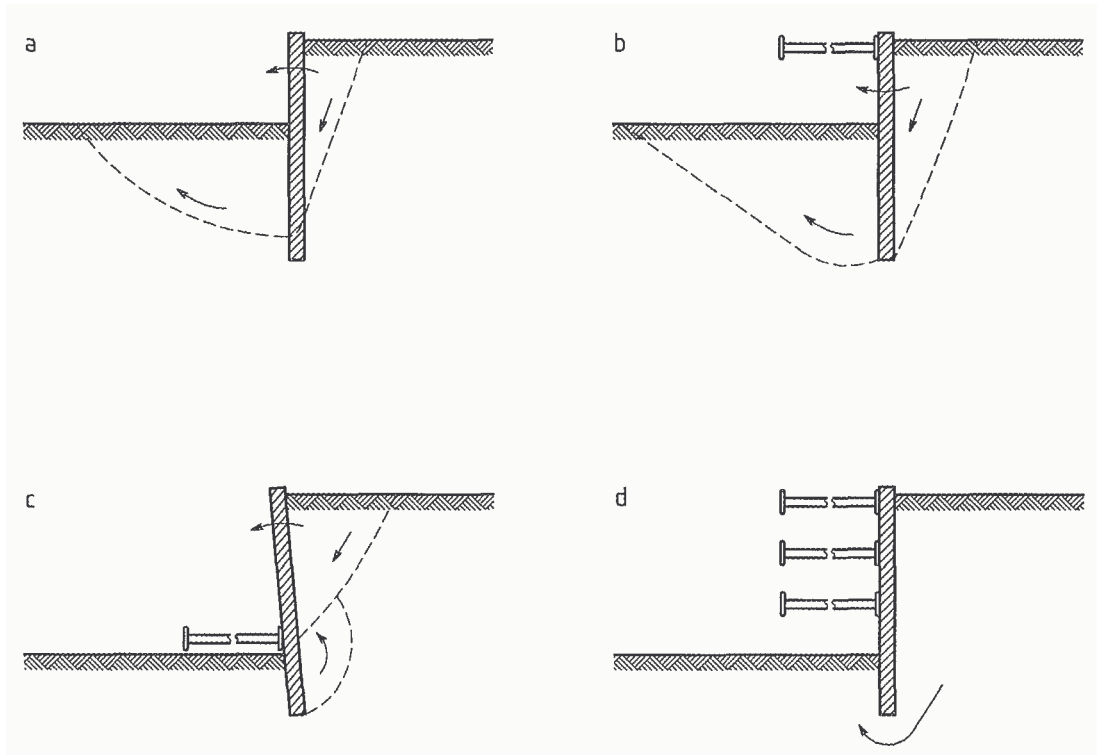

Figure 9.3 — Examples of limit modes for rotational failures of embedded walls

(2) As a minimum, limit modes of the types illustrated in Figure 9.3 should be considered.

(3)P The design magnitude and direction of shear stress between the soil and the wall shall be consistent with the relative vertical displacement, which would occur in the design situation.

9.7.5 Vertical failure of embedded walls

(1)P It shall be demonstrated that vertical equilibrium can be achieved using the design soil strengths or resistances and design vertical forces on the wall.

(2) As a minimum, the limit mode of the type illustrated in Figure 9.4 should be considered.

(3)P Where downward movement of the wall is considered, upper design values shall be used in the calculation of prestressing forces, such as those from ground $\boxed{A_1}$ anchors $\boxed{A_1}$, which have a vertical downward component.

(4)P The design magnitude and direction of shear stress between the soil and the wall shall be consistent with the check for vertical and rotational equilibrium.

(5)P If the wall acts as the foundation for a structure, vertical equilibrium shall be checked using the principles of $\boxed{AC_1}$ Section 7 $\boxed{AC_1}$.

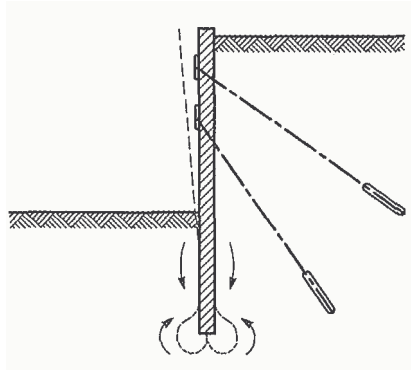

Figure 9.4 — Example of a limit mode for vertical failure of embedded walls

9.7.6 Structural design of retaining structures

(1) Retaining structures, including their supporting structural elements such as A_1 anchors A_1 and props, shall be verified against structural failure in accordance with 2.4 and EN 1992, EN 1993, EN 1995 and EN 1996.

(2) As a minimum, limit modes of the types illustrated in Figure 9.5 should be considered.

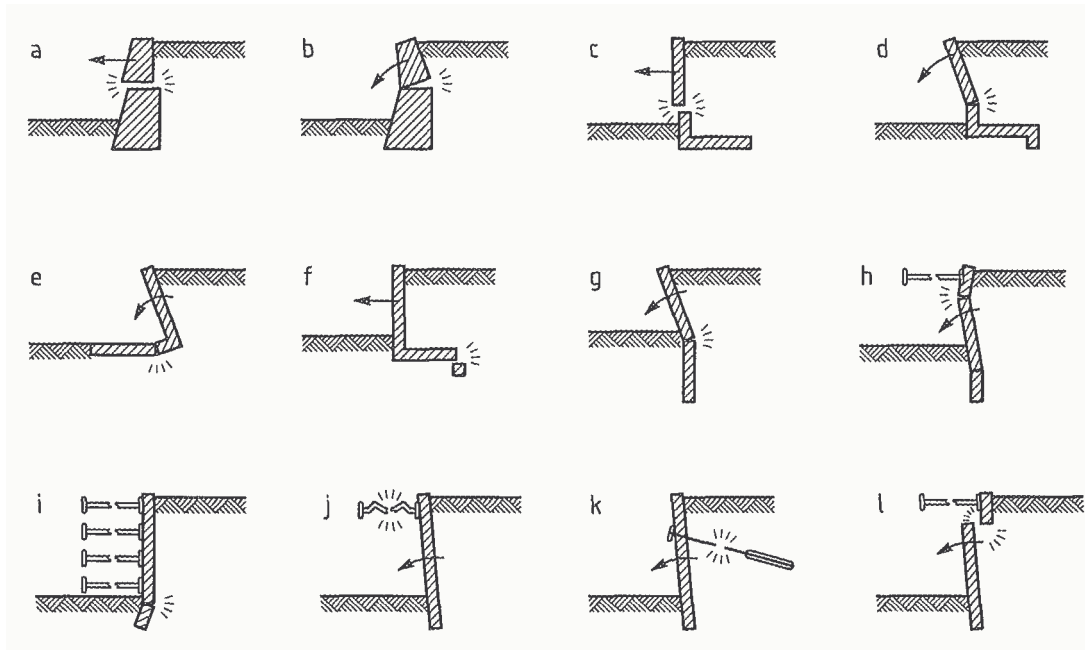

Figure 9.5 — Examples of limit modes for structural failure of retaining structures

(3) For each ultimate limit state, it shall be demonstrated that the required strengths can be mobilised, with compatible deformations in the ground and the structure.

(4) In structural elements, reduction in strength with deformation due to effects such as cracking of unreinforced sections, large rotations at plastic hinges or local buckling of steel sections should be considered in accordance with EN 1992 to EN 1996 and EN 1999.

9.7.7 Failure by pull-out of $\boxed{\text{AC}_1}$ anchors $\langle \text{AC}_1 \rangle$

(1)P It shall be demonstrated that equilibrium can be achieved without pull-out failure of ground $\boxed{\text{AC}_1}$ anchors $\langle \text{AC}_1 \rangle$.

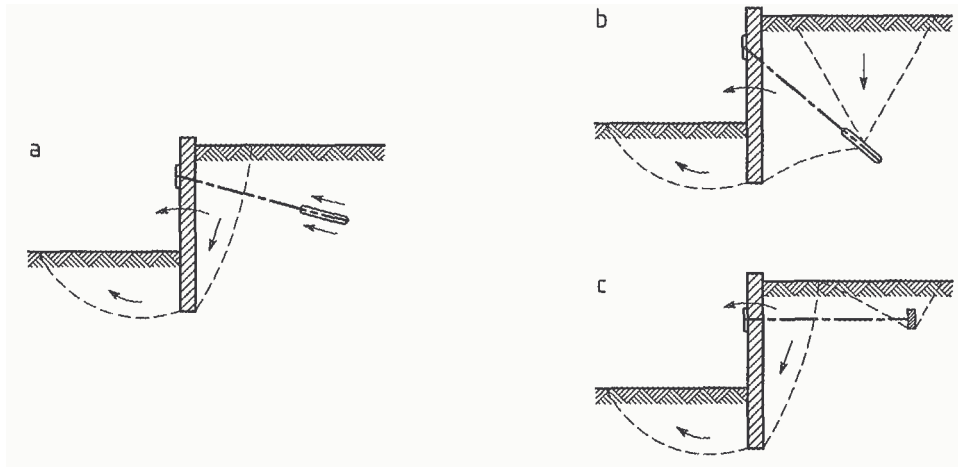

Figure 9.6 — Examples of limit modes for failure by pull-out of anchors.

(2)P Anchors shall be designed in accordance with Section 8.

(3) As a minimum, limit modes of the types illustrated in Figure 9.6 (a, b) should be considered.

(4) For deadman anchors, the failure mode illustrated in Figure 9.6 (c) should also be considered.

9.8 Serviceability limit state design

9.8.1 General

(1)P The design of retaining structures shall be checked at the serviceability limit state using the appropriate design situations as specified in 9.3.3.

$\boxed{\text{AC}_1}$ Text deleted $\langle \text{AC}_1 \rangle$

$\boxed{\text{AC}_1}$ (2) $\langle \text{AC}_1 \rangle$ The assessment of design values of earth pressures should take account of the initial stress, stiffness and strength of the ground and the stiffness of the structural elements.

$\boxed{\text{AC}_1}$ (3) $\langle \text{AC}_1 \rangle$ The design values of earth pressures should be derived taking account of the allowable deformation of the structure at its serviceability limit state. These pressures $\boxed{\text{AC}_1}$ need $\langle \text{AC}_1 \rangle$ not necessarily be limiting values.

9.8.2 Displacements

(1)P Limiting values for the allowable displacements of walls and the ground adjacent to them shall be established in accordance with 2.4.8, taking into account the tolerance to displacements of supported structures and services.

(2)P A cautious estimate of the distortion and displacement of retaining walls, and the effects on supported structures and services, shall always be made on the basis of comparable experience. This estimate shall include the effects of construction of the wall. The design may be justified by checking that the estimated displacements do not exceed the limiting values.

(3)P If the initial cautious estimate of displacement exceeds the limiting values, the design shall be justified by a more detailed investigation including displacement calculations.

(4)P It shall be considered to what extent variable actions, such as vibrations caused by traffic loads behind the retaining wall, contribute to the wall displacement.

(5)P A more detailed investigation, including displacement calculations, shall be undertaken in the following situations:

- where nearby structures and services are unusually sensitive to displacement;
- where comparable experience is not well established.

(6) Displacement calculations should also be considered in the following cases:

- where the wall retains more than 6 m of cohesive soil of low plasticity,
- where the wall retains more than 3 m of soils of high plasticity;
- where the wall is supported by soft clay within its height or beneath its base.

(7)P Displacement calculations shall take account of the stiffness of the ground and structural elements and the sequence of construction.

(8) The behaviour of materials assumed in displacement calculations should be calibrated by comparable experience with the same calculation model. If linear behaviour is assumed, the stiffnesses adopted for the ground and structural materials should be appropriate for the degree of deformation computed. Alternatively, complete stress-strain models of the materials may be adopted.

(9)P The effect of vibrations on displacements shall be considered with regard to 6.6.4.

Section 10 Hydraulic failure

10.1 General

(1)P The provisions of this Section apply to four modes of ground failure induced by pore-water pressure or pore-water seepage, which shall be checked, as relevant:

- failure by uplift (buoyancy);
- failure by heave;
- failure by internal erosion;
- failure by piping.

NOTE 1 Buoyancy occurs when pore-water pressure under a structure or a low permeability ground layer becomes larger than the mean overburden pressure (due to the structure and/or the overlying ground layer).

NOTE 2 Failure by heave occurs when upwards seepage forces act against the weight of the soil, reducing the vertical effective stress to zero. Soil particles are then lifted away by the vertical water flow and failure occurs (boiling).

NOTE 3 Failure by internal erosion is produced by the transport of soil particles within a soil stratum, at the interface of soil strata, or at the interface between the soil and a structure. This may finally result in regressive erosion, leading to collapse of the soil structure.

NOTE 4 Failure by piping is a particular form of failure, for example of a reservoir, by internal erosion, where erosion begins at the surface, then regresses until a pipe-shaped discharge tunnel is formed in the soil mass or between the soil and a foundation or at the interface between cohesive and non-cohesive soil strata. Failure occurs as soon as the upstream end of the eroded tunnel reaches the bottom of the reservoir.

NOTE 5 The conditions for hydraulic failure of the ground can be expressed in terms of total stress and pore-water pressure or in terms of effective stresses and hydraulic gradient. Total stress analysis is applied to failure by uplift. For failure by heave, both total and effective stresses are applied. Conditions are put on hydraulic gradients in order to control internal erosion and piping.

(2) In situations where the pore-water pressure is hydrostatic (negligible hydraulic gradient) it is not required to check other than failure by uplift.

(3)P The determination of hydraulic gradients, pore-water pressures or seepage forces shall take account of:

- the variation of soil permeability in time and space;
- variations in water levels and pore-water pressure in time;
- any modification of the boundary conditions (e.g. downstream excavation).

(4) It should be considered that the relevant soil stratification may be different for different failure mechanisms.

(5)P When hydraulic heave, piping or internal erosion are significant dangers to the integrity of a geotechnical structure, measures shall be taken to decrease the hydraulic gradient.

(6) The measures most commonly adopted to reduce erosion or to avoid hydraulic failure are:

- lengthening the seepage path by screens or shoulders;

- modifications of the project in order to resist the pressures or gradients;
- seepage control;
- protective filters;
- avoidance of dispersive clays without adequate filters;
- slope revetments;
- inverted filters;
- relief wells;
- reduction of hydraulic gradient.

10.2 Failure by uplift

(1)P The stability of a structure or of a low permeability ground layer against uplift shall be checked by comparing the permanent stabilising actions (for example, weight and side friction) to the permanent and variable destabilising actions from water and, possibly, other sources. Examples of situations where uplift stability shall be checked are given in Figure 7.1 and Figure 10.1.

(2)P The design shall be checked against failure by uplift using inequality (2.8) of 2.4.7.4. In this inequality, the design value of the vertical component of the stabilising permanent actions ($G_{stb;d}$) is, for example, the weight of the structure and of ground layers, $\overline{AC1}$ while $\overline{AC1}$ the design resistance (R_d) is the sum of, for example, any friction forces, (T_d), and any anchor forces, (P). Resistance to uplift by friction or anchor forces may also be treated as a stabilising permanent vertical action ($G_{stb;d}$). The design value of the vertical component of the destabilising permanent and variable actions, ($V_{dst;d}$), is the sum of the water pressures applied under the structure (permanent and variable parts) and any other upwards forces.

$\overline{AC1}$ (3) If allowed by the National Annex, resistance to uplift by friction or anchor forces may also be treated as a stabilising permanent vertical action ($G_{stb;d}$).

NOTE The values of the partial factors may be set by the National Annex. $\overline{AC1}$

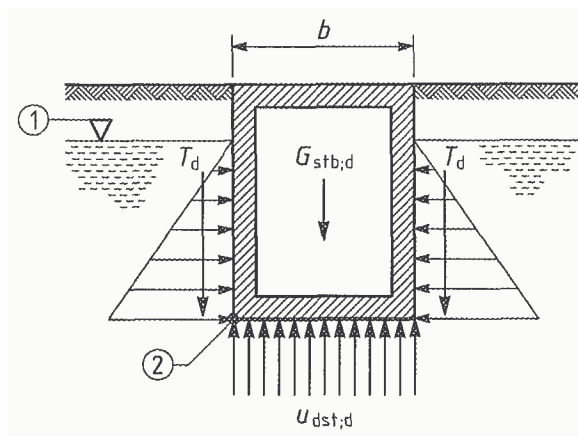

a) Uplift of a buried hollow structure

- 1 $\overline{AC1}$ groundwater table $\overline{AC1}$
- 2 water tight surface

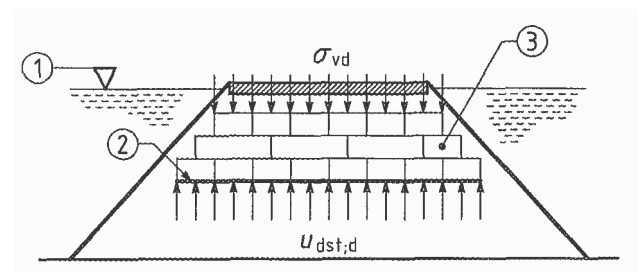

b) Uplift of a lightweight embankment during flood

- 1 $\overline{AC1}$ groundwater table $\overline{AC1}$
- 2 water tight surface
- 3 light weight embankment material

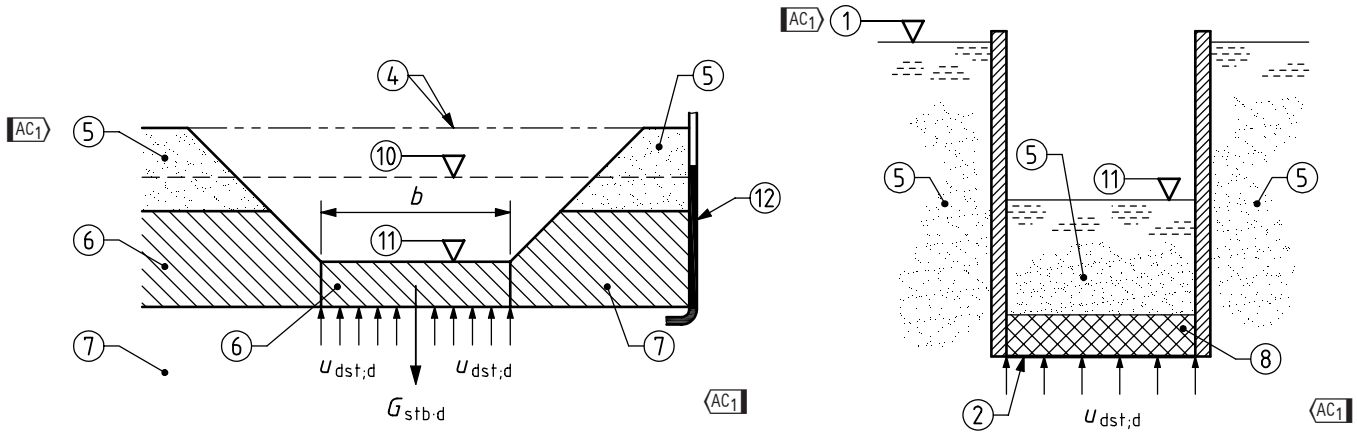

c) Uplift of the bottom of an excavation

d) Execution of a slab below water level

4 former ground surface

5 sand

6 clay

7 gravel

10 groundwater level before the excavation

11 groundwater level in the excavation

12 piezometric level at the base of the clay layer

1 groundwater table

2 water tight surface

5 sand

~~Text deleted~~

8 injected sand

11 groundwater level in the excavation

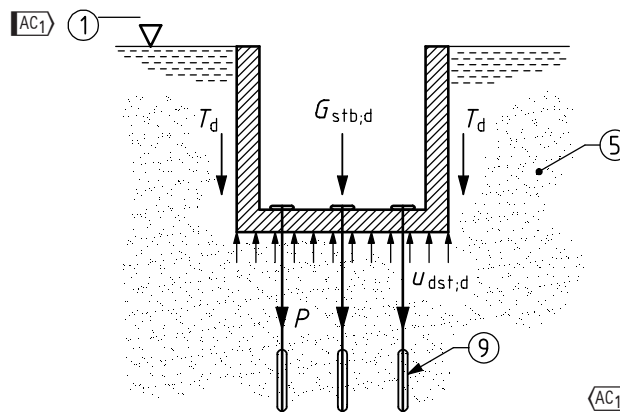

e) Structure anchored to resist uplift

1 groundwater table

5 sand

9 anchor

Figure 10.1 — Examples of situations where uplift might be critical

(4) The measures most commonly adopted to resist failure by uplift are:

- increasing the weight of the structure;
- decreasing the water pressure below the structure by drainage;
- anchoring the structure in the underlying strata.

(5)P Where piles or anchors are used to provide resistance against failure by uplift, the design shall be checked according to 7.6.3 or 8.5, respectively, using the partial factors given in 2.4.7.4.

10.3 Failure by heave

(1)P The stability of soil against heave shall be checked by verifying either equation (2.9a) or equation (2.9b) for every relevant soil column. Equation (2.9a) expresses the condition for stability in terms of pore-water pressures and total stresses. Equation (2.9b) expresses the same condition in terms of seepage forces and submerged weights. An example of situations where heave shall be checked is given in Figure 10.2.

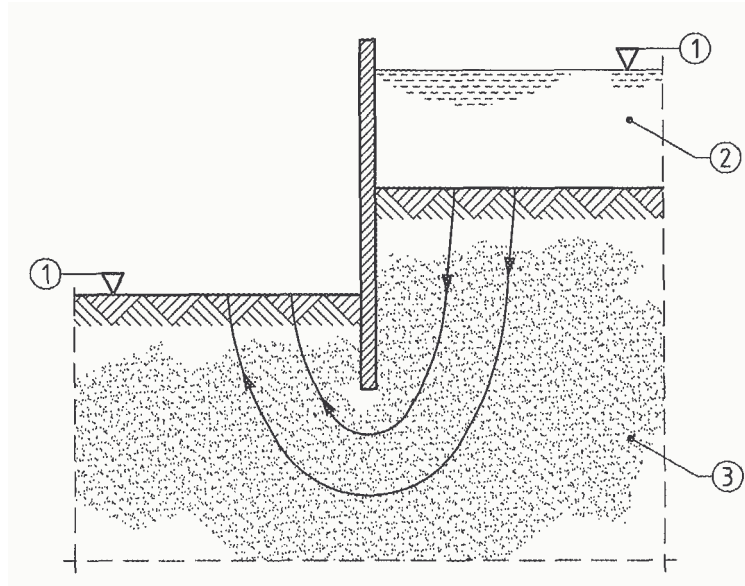

1 excavation level (left); free-water level (right)
2 water
3 sand

Figure 10.2 — Example of situation where heave might be critical

(2)P The determination of the characteristic value of the pore-water pressure shall take into account all possible unfavourable conditions, such as:

- thin layers of soil of low permeability;
- spatial effects such as narrow, circular or rectangular excavations below water level.

NOTE 1 Where the soil has a significant cohesive shear resistance, the mode of failure changes from failure by heave to failure by uplift. The stability is then checked by using the provisions of 10.2 where additional resisting forces may be added to the weight.

NOTE 2 Stability against heave will not necessarily prevent internal erosion, which should be checked independently, when relevant.

(3) The measures most commonly adopted to resist failure by heave are:

- decreasing the water pressure below the soil mass subjected to heave;
- increasing the resisting weight.

10.4 Internal erosion

(1)P Filter criteria shall be used to limit the danger of material transport by internal erosion.

(2)P Where an ultimate limit state due to internal erosion can occur, measures such as filter protection shall be applied at the free surface of the ground.

(3) Filter protection should generally be provided by use of natural non-cohesive soil that fulfils adequate design criteria for filter materials. In some cases, more than one filter layer may be necessary to ensure that the particle size distribution changes in a stepwise fashion to obtain sufficient protection both for the soil and the filter layers.

(4) Alternatively, artificial filter sheets such as geotextiles may be used provided it can be established that they sufficiently prevent transport of fines.

AC1 (5)P If the filter criteria are not satisfied, it shall be verified that the design value of the hydraulic gradient is well below the critical hydraulic gradient at which soil particles begin to move. AC1

(6)P The critical hydraulic gradient for internal erosion shall be established taking into consideration at least the following aspects:

- direction of flow;
- grain size distribution and shape of grains;
- stratification of the soil.

10.5 Failure by piping

(1)P Where prevailing hydraulic and soil conditions can lead to the occurrence of piping (see figure 10.3), and where piping endangers the stability or serviceability of the hydraulic structure, prescriptive measures shall be taken to prevent the onset of the piping process, either by the application of filters or by taking structural measures to control or to block the ground-water flow.

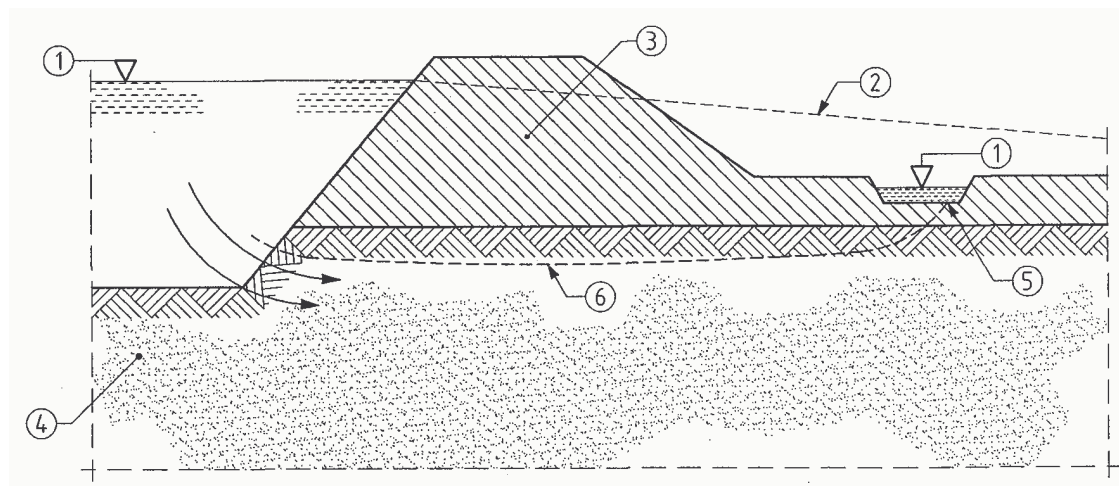

- AC1 1 free-water level AC1
- 2 piezometric level in the permeable subsoil
 - 3 low permeability soil
 - 4 permeable subsoil
 - 5 possible well; starting point for pipe
 - 6 possible pipe

Figure 10.3 — Example of conditions that may cause piping

NOTE Suitable structural measures are:

- application of berms on the land side of a retaining embankment, thus displacing the possible starting point of piping farther away from the structure and decreasing the hydraulic gradient at this point;
- application of impermeable screens below the base of $\overline{AC_1}$ the $\overline{AC_1}$ hydraulic structure by which the ground-water flow is either blocked or the seepage path is increased, thereby decreasing the hydraulic gradient to a safe value.

(2)P During periods of extremely unfavourable hydraulic conditions such as floods, areas susceptible to piping shall be inspected regularly so that necessary mitigating measures can be taken without delay. Materials for such measures shall be stored in the vicinity.

(3)P Failure by piping shall be prevented by providing sufficient resistance against internal soil erosion in the areas where water outflow may occur.

(4) Such failure can be prevented by providing:

- sufficient safety against failure by heave where the ground surface is horizontal;
- sufficient stability of the surface layers in sloping ground (local slope stability).

(5)P When determining the outflow hydraulic conditions for the verification of failure by heave or of local slope stability, account shall be taken of the fact that joints or interfaces between the structure and the ground can become preferred seepage paths.

Section 11 Overall stability

11.1 General

(1)P The provisions in this Section shall apply to the overall stability of and movements in the ground, whether natural or fill, around foundations, retaining structures, natural slopes, embankments or excavations.

(2) Account should be taken of overall stability clauses, related to specific structures, in Sections 6 to 10 and 12.

11.2 Limit states

(1)P All possible limit states for the particular ground shall be considered in order to fulfil the fundamental requirements of stability, limited deformations, durability and limitations in movements of nearby structures or services.

(2) Some possible limit states are listed below:

- loss of overall stability of the ground and associated structures;
- excessive movements in the ground due to shear deformations, settlement, vibration or heave;
- damage or loss of serviceability in neighbouring structures, roads or services due to movements in the ground.

11.3 Actions and design situations

(1) The list in 2.4.2(4) should be taken into account when selecting the actions for calculation of limit states.

(2)P The effects of the following circumstances shall be taken into account, as appropriate:

- construction processes;
- new slopes or structures on or near the particular site;
- previous or continuing ground movements from different sources;
- vibrations;
- climatic variations, including temperature change (freezing and thawing), drought and heavy rain;
- vegetation or its removal;
- human or animal activities;
- variations in water content or pore-water pressure;
- wave action.

(3)P In ultimate limit states, design free water and ground-water levels, or their combination, shall be selected from available hydrological data and in situ observations to give the most unfavourable conditions that could occur in the design situation being considered. The possibility of failure of drains, filters or seals shall be considered.

(4) The possibility of emptying a canal or water reservoir for maintenance, or due to dam failure, should also be considered. For serviceability limit states, less severe, more typical water level or pore-water pressure may be used.

(5) For slopes along waterfronts, the most unfavourable hydraulic conditions are normally steady seepage for the highest possible ground-water level and rapid draw-down of the free water level.

(6)P In deriving design distributions of pore-water pressure, account shall be taken of the possible range of permeability anisotropy and variability of the ground.

11.4 Design and construction considerations

(1)P The overall stability of a site and movements of natural or made ground shall be checked taking into account comparable experience, according to 1.5.2.2.

(2)P The overall stability and movement of ground supporting existing buildings, new structures, slopes or excavations shall be considered.

(3) In cases where the stability of the ground cannot be clearly verified prior to design, additional investigations, monitoring and analysis should be specified according to the provisions of 11.7.

(4) Typical structures for which an analysis of overall stability should be performed are:

- ground retaining structures;
- excavations, slopes or embankments;
- foundations on sloping ground, natural slopes or embankments;
- foundations near an excavation, cut or buried structures, or shore.

NOTE Stability problems or creep movements occur primarily in cohesive soils with a sloping ground surface. However, instability can also occur in non-cohesive soils and fissured rocks in slopes where the inclination, which may be determined by erosion, is close to the angle of shearing resistance. Increased movements are often observed at elevated pore-water pressures or close to the ground surface during freezing and thawing cycles.

(5)P If the stability of a site cannot readily be verified or the movements are found to be not acceptable for the site's intended use, the site shall be judged to be unsuitable without stabilising measures.

(6)P The design shall ensure that all construction activities in and on the site can be planned and executed such that the occurrence of an ultimate or serviceability limit state is sufficiently improbable.

(7)P Slope surfaces exposed to potential erosion shall be protected if required, to ensure that the safety level is retained.

(8) Slopes should be sealed, planted or protected artificially. For slopes with berms, a drainage system within the berm should be considered.

(9)P Construction processes shall be taken into account as far as they might affect the overall stability or the magnitude of movement.

(10) Potentially unstable slopes may be stabilised by:

- a concrete cover with or without $\boxed{A_1}$ anchor $\boxed{A_1}$;

- an abutment of gabions, either of steel net or geotextile cages;
- ground nailing;
- vegetation;
- a drainage system;
- a combination of the above.

(11) The design should follow the general principles of Sections 8 and 9.

11.5 Ultimate limit state design

11.5.1 Stability analysis for slopes

(1)P The overall stability of slopes including existing, affected or planned structures shall be verified in ultimate limit states (GEO and STR) with design values of actions, resistances and strengths, where the partial factors defined in A.3.1(1)P, A.3.2(1)P and A.3.3.6(1)P shall be used.

NOTE The values of the partial factors may be set by the National annex. The recommended values for persistent and transient situations are given in Tables A.3, A.4 and A.14.

(2)P In analysing the overall stability of the ground, of soil or rock, all relevant modes of failure shall be taken into account.

(3) When choosing a calculation method, the following should be considered:

- soil layering;
- occurrence and inclination of discontinuities;
- seepage and pore-water pressure distribution;
- short- and long-term stability;
- creep deformations due to shear;
- type of failure (circular or non-circular surface; toppling; flow);
- use of numerical methods.

(4) The mass of soil or rock bounded by the failure surface should normally be treated as a rigid body or as several rigid bodies moving simultaneously. Failure surfaces or interfaces between rigid bodies may have a variety of shapes including planar, circular and more complicated shapes. Alternatively, stability may be checked by limit analysis or using the finite element method.

(5) Where ground or embankment material is relatively homogeneous and isotropic, circular failure surfaces should normally be assumed.

(6) For slopes in layered soils with considerable variations of shear strength, special attention should be paid to the layers with lower shear strength. This may require analysis of non-circular failure surfaces.

(7) In jointed materials, including hard rock and layered or fissured soils, the shape of the failure surface can partly or fully be governed by discontinuities. In this case analysis of three-dimensional wedges should normally be made.

(8) Existing failed slopes, which can potentially be reactivated should be analysed, considering circular, as well as non-circular failure surfaces. Partial factors normally used for overall stability analyses then need not be appropriate.

(9) If the failure surface cannot be assumed to be two-dimensional, the use of three-dimensional failure surfaces should be considered.

(10) A slope analysis should verify the overall moment and vertical stability of the sliding mass. AC1 If a method of slices is used and horizontal equilibrium is not checked, the inter-slices forces should be assumed to be horizontal. AC1

(11)P In cases where a combined failure of structural members and the ground could occur, ground-structure interaction shall be considered by allowing for the difference in their relative stiffnesses. Such cases include failure surfaces intersecting structural members such as piles and flexible walls.

AC1 Note deleted AC1

(12) Since a distinction between favourable and unfavourable gravity loads is not possible in assessing the most adverse slip surface, any uncertainty about weight density of the ground should be considered by applying upper and lower characteristic values of it.

(13)P The design shall show that the deformation of the ground under design actions due to creep or regional settlements will not cause unacceptable damage to structures or infrastructure sited on, in or near the particular ground.

11.5.2 Slopes and cuts in rock masses

(1)P The stability of slopes and cuts in rock masses shall be checked against translational and rotational modes of failure involving isolated rock blocks or large portions of the rock mass, and also against rock falls. Particular attention shall be given to the pressure caused by blocked seepage water in joints and fissures.

(2)P Stability analyses shall be based on reliable knowledge of the pattern of discontinuities intersecting the rock mass and of the shear strength of the intact rock and of the discontinuities.

(3) Account should be taken of the fact that failure of slopes and cuts in hard rock masses, with a well defined pattern of discontinuities, will generally involve:

- sliding of blocks or rock wedges;
- toppling of blocks or slabs;
- a combination of toppling and sliding.

depending on the orientation of the slope face in relation to that of the discontinuities.

(4) It should be considered that failure of slopes and cuts in highly fissured rock masses and in soft rocks and cemented soils may develop along circular or almost circular slip surfaces passing through portions of intact rock.

(5) Sliding of isolated blocks and wedges should usually be prevented by reducing the inclination of the slope by providing berms, and installing anchors, bolts and internal drainage. In cutting slopes, sliding should be prevented by selecting the direction and orientation of the slope face so that movements of isolated blocks are kinematically impossible.

(6) To prevent toppling failures, anchoring or bolting and internal drainage should normally be applied.

(7) When considering the long-term stability of slopes and cuts, the detrimental effects of vegetation and environmental or polluting agents on the shear strength of discontinuities and on the strength of the intact rock should be taken into account.

(8) In highly fractured rock masses in steep slopes and slopes susceptible to toppling, spalling, ravelling and slumping, the possibility of rock falls should always be analysed.

(9) In cases where reliable provisions to prevent rock falls are not feasible, rock falls should be allowed to occur with the provision of nets, barriers or other suitable provision to trap the falling rock.

(10) The design of provisions to trap rock blocks and debris falling down a rock slope should be based on a thorough investigation of the possible trajectories of the falling material.

11.5.3 Stability of excavations

(1)P The overall stability of the ground close to an excavation, including excavation spoil and existing structures, roads and services shall be checked (see Section 9).

(2)P The stability of the bottom of an excavation shall be checked in relation to the design pore-water pressure in the ground. For the analysis of hydraulic failure (see Section 10).

(3)P Heave of the bottom of deep excavations due to unloading shall be considered.

11.6 Serviceability limit state design

(1)P The design shall show that the deformation of the ground will not cause a serviceability limit state in structures and infrastructure on or near the particular ground.

(2) Subsidence of the ground due to the following causes should be considered:

- change in ground-water conditions and corresponding pore-water pressures;
- long-term creep under drained conditions;
- volume loss of deep soluble strata;
- mining or similar works such as gas extraction.

(3) Since the analytical and numerical methods available at present do not usually provide reliable predictions of the deformation of a natural slope, the occurrence of serviceability limit states should be avoided by one of the following:

- limiting the mobilised shear strength;
- observing the movements and specifying actions to reduce or stop them, if necessary.

11.7 Monitoring

(1)P The ground shall be monitored using appropriate equipment if:

- it is not possible to prove by calculation or by prescriptive measures that the occurrence of the limit states given in 11.2 is sufficiently unlikely;
- the assumptions made in the calculations are not based on reliable data.

(2) Monitoring should be planned to provide knowledge of:

- ground-water levels or pore-water pressures in the ground, so that effective stress analyses can be carried out or checked;
- lateral and vertical ground movements, in order to predict further deformations;
- the depth and shape of the moving surface in a developed slide, in order to derive the ground strength parameters for the design of remedial works;
- rates of movement, in order to give warning of impending danger; in such cases a remote digital readout for the instruments or a remote alarm system may be appropriate.

Section 12 Embankments

12.1 General

(1)P The provisions of this Section shall apply to embankments for small dams and for infrastructure.

(2) For placement and compaction of fill the provisions in Section 5 should be applied.

12.2 Limit states

(1)P A list shall be compiled of limit states to be checked in the design of the embankment.

(2) The following limit states should be checked:

- loss of overall site stability;
- failure in the embankment slope or crest;
- failure caused by internal erosion;
- failure caused by surface erosion or scour;
- deformations in the embankment leading to loss of serviceability, e.g. excessive settlements or cracks;
- settlements and creep displacements leading to damages or loss of serviceability in nearby structures or utilities;
- excessive deformations in transition zones, e.g. the access embankment of a bridge abutment;
- loss of serviceability of traffic areas by climatic influences such as freezing and thawing or extreme drying;
- creep in slopes during the freezing and thawing period;
- degradation of base course material due to high traffic loads;
- deformations caused by hydraulic actions;
- changes of environmental conditions such as pollution of surface or ground-water, noise or vibrations.

12.3 Actions and design situations

(1) In selecting the actions for the calculation of limit states, the list in 2.4.2.(4) should be considered.

(2) When deriving the actions that embankments impose on adjacent structures or any reinforced parts of the ground, the differences in the stiffnesses should be considered.

(3)P Design situations shall be selected in accordance with 2.2.

(4)P In addition, the following special design situations shall be taken into account, if relevant:

- the effects of the construction process, such as excavations close to the embankment fill and vibrations caused by blasting, pile driving or heavy equipment;
- the effects of structures planned to be constructed on or close to the embankment;
- the erosion effects of overtopping, ice, waves and rain on the slopes and crest;
- temperature effects such as shrinkage.

(5)P The design free water level on the downstream embankment slope and the design ground-water level, or their combination, shall be based on available hydrological data to give the most unfavourable conditions that could occur in the design situation considered. The possibility of failure of drains, filters or seals shall be considered.

(6) For shore embankments, the most unfavourable hydraulic conditions should be considered. These are normally steady seepage for the highest possible ground-water level and rapid draw-down of the free water level.

(7)P In deriving design distributions of pore-water pressure, account shall be taken of the possible range of anisotropy and heterogeneity of the soil.

(8)P When designing the embankment with respect to settlement, the effective stress decrease in the ground, due to submergence of the dry crust or the fill, shall be taken into account.

12.4 Design and construction considerations

(1)P Embankments shall be designed taking into account experience with embankments on similar ground and made of similar fill material.

(2)P When assessing the foundation level for an embankment, the following shall be considered, when applicable:

- reaching an adequate bearing stratum, or applying stabilising measures where this is not practicable;
- providing sufficient protection against adverse climatic effects on the bearing capacity of the ground;
- the ground-water level with respect to the drainage of the embankment;
- avoiding adverse effects on adjacent structures and utilities;
- reaching layers with adequately low permeability.

(3) Design of embankments should ensure that:

- the bearing capacity of the subsoil is satisfactory;
- the drainage of the various fill layers is satisfactory;
- the permeability of the fill material in dams is as low as required;
- filters or geosynthetics are specified where necessary to fulfil filter criteria;
- the fill material is specified according to the criteria in 5.3.2.

(4)P For embankments on ground with low strength and high compressibility, the construction process shall be specified so as to ensure that the bearing capacity is not exceeded and that excessive settlements or movements do not occur during construction (see 5.3.3(2)P).

- (5) When an embankment on compressible ground is raised in layers, piezometer measurements should be specified to ensure that pore-water pressures have dissipated to acceptably low values before the next fill layer is placed.
- (6)P For embankments retaining water at different levels, the foundation level shall be chosen with respect to the permeability of the ground or measures shall be taken to make the structure watertight.
- (7) If ground improvement is specified, the volume of ground to be improved should be designed with sufficient areal extent to avoid harmful deformations.
- (8) When determining the weight of the embankment from the weight density of fill (see 3.3.3), care should be taken to include fill particles of size > 20 mm to 60 mm in the density tests. They are often not included but can have a considerable effect on the weight density.
- (9)P Embankment slope surfaces exposed to erosion shall be protected. If berms are designed, a drainage facility shall be specified for the berm.
- (10) The slopes should be sealed during embankment construction and planted thereafter, where appropriate.
- (11) For embankments carrying traffic, icing on the surface of the pavement should be avoided. The thermal capacity of a pavement on an insulation layer or a lightweight fill may be high enough to avoid this.
- (12) Frost penetration on the crest of an earth dam should be restricted to an appropriate level.
- (13) Design of the embankment slope should consider that creep movements may occur in slopes during freezing and thawing irrespective of the slope stability under dry conditions. This is especially important in transition zones, e.g. at bridge abutments.

12.5 Ultimate limit state design

- (1)P In analysing the stability of part or all of an embankment, all possible failure modes shall be considered, as stated in Section 11.
- (2) Since embankments are often constructed in different phases with different load conditions, the analysis should be done phase by phase and provisions specified accordingly in the Geotechnical Design Report.
- (3)P Where lightweight fill materials such as expanded polystyrene, expanded clay or foamed concrete are used, the possibility of buoyancy effects shall be considered (see Section 10).
- (4)P Any analysis of embankments containing different fill materials shall adopt strength values that have been determined at compatible strains in the materials.
- (5) Where roads or watercourses cross an embankment, special attention should be paid to the spatial interaction of the various structural elements.
- (6) When analysing the stability of improved ground, the effect of the improving process, e.g. the disturbance of soft sensitive clay, should be considered. As the effect of the improvement is time-dependent, it should not be taken into account until a steady state has been reached.
- (7)P To avoid ultimate limit states caused by surface erosion, internal erosion or hydraulic pressure, the provisions in Sections 10 and 11 shall be fulfilled.

12.6 Serviceability limit state design

(1)P The design shall show that the deformation of the embankment will not cause a serviceability limit state in the embankment or in structures, roads or services sited on, in or near the embankment.

(2) The settlement of an embankment on compressible ground should be calculated using the principles of 6.6.1. Special attention should be paid to the time dependency of the settlements due to both consolidation and secondary effects.

(3) The possibility of deformations due to changes in the ground-water conditions should be taken into account.

(4) In cases where the deformations are difficult to predict, the methods of pre-loading or trial embankments should be considered, especially in cases where serviceability limit states shall be prevented.

12.7 Supervision and monitoring

(1)P Supervision and monitoring of embankments shall follow the provisions in Section 4.

(2) Monitoring should be applied to embankments in one or more of the following situations:

- when using the observational method (see 2.7);
- where the stability of an embankment acting as a dam to a large degree depends on the pore-water pressure distribution in and beneath the embankment;
- where records of pollution effects of fill or traffic are required;
- where control of adverse effects on structures or utilities is required;
- where surface erosion is a considerable risk.

(3)P In cases where a supervision and monitoring programme is required, the designer shall present it in the Geotechnical Design Report (see 2.8). It shall be specified that the monitoring records are to be evaluated and acted upon as necessary.

(4) A monitoring programme for an embankment should contain the following records:

- pore-water pressure measurements in and beneath the embankment;
- settlement measurements for the whole or parts of the embankment and influenced structures;
- measurements of horizontal displacements;
- checks on strength parameters of fill material during construction;
- chemical analyses before, during and after construction, if pollution control is required;
- observations of erosion protection;
- checks on permeability of fill material and of foundation soil during construction;
- depth of frost penetration in the crest of an embankment.

(5) The construction of embankments on soft soil with low permeability should be monitored and controlled by means of pore-water pressure measurements in the soft layers and settlement measurements of the fill.

Annex A (normative)

A1 Partial and correlation factors for ultimate and serviceability limit states and recommended values A1

A.1 Partial factors and correlation factors

A1 (1)P The partial factors γ for ultimate limit states in persistent and transient design situations shall be those mentioned in this annex.

(2)P The partial factors γ for serviceability limit states for anchors shall be those mentioned in this annex.

(3)P The correlation factors ξ for pile foundations and anchors in all design situations shall be those mentioned in this annex. A1

A.1 Partial factors and correlation factors

(1)P The partial factors γ for ultimate limit states in persistent and transient design situations, and the correlation factors ξ for pile foundations in all design situations, shall be those mentioned in this annex.

A.2 Partial factors for equilibrium limit state (EQU) verification

(1)P For the verification of equilibrium limit state (EQU) the following partial factors on actions γ_F shall be applied:

- $\gamma_{G;dst}$ on destabilising unfavourable permanent actions;
- $\gamma_{G;stb}$ on stabilising favourable permanent actions;
- $\gamma_{Q;dst}$ on destabilising unfavourable variable actions;
- $\gamma_{Q;stb}$ on stabilising favourable variable actions.

NOTE The values to be ascribed to $\gamma_{G;dst}$, $\gamma_{G;stb}$, $\gamma_{Q;dst}$ and $\gamma_{Q;stb}$ for use in a country may be found in its National annex to EN 1990:2002. The recommended values for buildings in EN 1990:2002 are given in Table A.1.

Table A.1 Partial factors on actions (γ_F)

Action	Symbol	Value
Permanent		
Unfavourable ^a	$\gamma_{G;dst}$	1,1
Favourable ^b	$\gamma_{G;stb}$	0,9
Variable		
Unfavourable ^a	$\gamma_{Q;dst}$	1,5
Favourable ^b	$\gamma_{Q;stb}$	0
^a Destabilising ^b Stabilising		

(2)P For the verification of equilibrium limit state (EQU) the following partial factors on soil parameters γ_M shall be applied, when including minor shearing resistances:

- γ_ϕ on the tangent of the angle of shearing resistance;
- γ_c on effective cohesion;
- γ_{cu} on undrained shear strength;
- γ_{qu} on unconfined strength;
- γ_γ on weight density.

NOTE The values to be ascribed to γ_ϕ , γ_c , γ_{cu} , γ_{qu} , and γ_γ for use in a country may be found in its National annex to this standard. The recommended values are given in Table A.2.

Table A.2 - Partial factors for soil parameters (γ_M)

Soil parameter	Symbol	Value
Angle of shearing resistance ^a	γ_ϕ	1,25
Effective cohesion	γ_c	1,25
Undrained shear strength	γ_{cu}	1,4
Unconfined strength	γ_{qu}	1,4
Weight density	γ_γ	1,0
^a This factor is applied to $\tan \phi$		

A.3 Partial factors for structural (STR) and geotechnical (GEO) limit states verification

A.3.1 Partial factors on actions (γ_F) or the effects of actions (γ_E)

(1)P For the verification of structural (STR) and geotechnical (GEO) limit states set A1 or set A2 of the following partial factors on actions (γ_F) or the effects of actions (γ_E) shall be applied:

- γ_G on permanent unfavourable or favourable actions;
- γ_Q on variable unfavourable or favourable actions.

NOTE The values to be ascribed to γ_G and γ_Q for use in a country may be found in its National annex to EN 1990:2002. The recommended values for buildings in EN 1990:2002 for the two sets A1 and A2 are given in Table A.3.

Table A.3 - Partial factors on actions (γ_F) or the effects of actions (γ_E)

Action		Symbol	Set	
			A1	A2
Permanent	Unfavourable	γ_G	1,35	1,0
	Favourable		1,0	1,0
Variable	Unfavourable	γ_Q	1,5	1,3
	Favourable		0	0

A.3.2 Partial factors for soil parameters (γ_M)

(1)P For the verification of structural (STR) and geotechnical (GEO) limit states set *M1* or set *M2* of the following partial factors on soil parameters(γ_M) shall be applied:

- γ_{ϕ} on the tangent of the angle of shearing resistance;
- γ_c on effective cohesion;
- γ_{c_u} on undrained shear strength;
- γ_{q_u} on unconfined strength;
- γ_γ on weight density.

NOTE The values to be ascribed to γ_{ϕ} , γ_c , γ_{c_u} , γ_{q_u} and γ_γ for use in a country may be found in its National annex to this standard. The recommended values for the two sets *M1* and *M2* are given in Table A.4.

Table A.4 - Partial factors for soil parameters(γ_M)

Soil parameter	Symbol	Set	
		M1	M2
Angle of shearing resistance ^a	γ_{ϕ}	1,0	1,25
Effective cohesion	γ_c	1,0	1,25
Undrained shear strength	γ_{c_u}	1,0	1,4
Unconfined strength	γ_{q_u}	1,0	1,4
Weight density	γ_γ	1,0	1,0
^a This factor is applied to $\tan \phi$			

A.3.3 Partial resistance factors (γ_R)

A.3.3.1 Partial resistance factors for spread foundations

(1)P For spread foundations and verifications of structural (STR) and geotechnical (GEO) limit states, set $R1$, $R2$ or $R3$ of the following partial factors on resistance (γ_R) shall be applied:

- $\gamma_{R,v}$ on bearing resistance;
- $\gamma_{R,h}$ on sliding resistance.

NOTE The values to be ascribed to $\gamma_{R,v}$ and $\gamma_{R,h}$ for use in a country may be found in its National annex to this standard. The recommended values for the three sets $R1$, $R2$ and $R3$ are given in Table A.5.

Table A.5 - Partial resistance factors (γ_R) for spread foundations

Resistance	Symbol	Set		
		$R1$	$R2$	$R3$
Bearing	$\gamma_{R,v}$	1,0	1,4	1,0
Sliding	$\gamma_{R,h}$	1,0	1,1	1,0

A.3.3.2 Partial resistance factors for pile foundations

(1)P For pile foundations and verifications of structural (STR) and geotechnical (GEO) limit states, set $R1$, $R2$, $R3$ or $R4$ of the following partial factors on resistance (γ_R) shall be applied :

- γ_b on base resistance;
- γ_s on shaft resistance for piles in compression;
- γ_t on total/combined resistance for piles in compression;
- $\gamma_{s,t}$ on shaft resistance for piles in tension.

NOTE The values to be ascribed to γ_b , γ_s , γ_t and $\gamma_{s,t}$ for use in a country may be found in its National annex to this standard. The recommended values for the four sets $R1$, $R2$, $R3$ and $R4$ are given in Table A.6 for driven piles, in Table A.7 for bored piles and in Table A.8 for continuous flight auger (CFA) piles.

Table A.6- Partial resistance factors (γ_R) for driven piles

Resistance	Symbol	Set			
		<i>R1</i>	<i>R2</i>	<i>R3</i>	<i>R4</i>
Base	γ_b	1,0	1,1	1,0	1,3
Shaft (compression)	γ_s	1,0	1,1	1,0	1,3
Total/combined (compression)	γ_t	1,0	1,1	1,0	1,3
Shaft in tension	$\gamma_{s;t}$	1,25	1,15	1,1	1,6

Table A.7 - Partial resistance factors (γ_R) for bored piles

Resistance	Symbol	Set			
		<i>R1</i>	<i>R2</i>	<i>R3</i>	<i>R4</i>
Base	γ_b	1,25	1,1	1,0	1,6
Shaft (compression)	γ_s	1,0	1,1	1,0	1,3
Total/combined (compression)	γ_t	1,15	1,1	1,0	1,5
Shaft in tension	$\gamma_{s;t}$	1,25	1,15	1,1	1,6

Table A.8 - Partial resistance factors (γ_R) for continuous flight auger (CFA) piles

Resistance	Symbol	Set			
		<i>R1</i>	<i>R2</i>	<i>R3</i>	<i>R4</i>
Base	γ_b	1,1	1,1	1,0	1,45
Shaft (compression)	γ_s	1,0	1,1	1,0	1,3
Total/combined (compression)	γ_t	1,1	1,1	1,0	1,4
Shaft in tension	$\gamma_{s;t}$	1,25	1,15	1,1	1,6

A.3.3.3 Correlation factors for pile foundations

(1) P For verifications of structural (STR) and geotechnical (GEO) limit states, the following correlation factors ξ shall be applied to derive the characteristic resistance of axially loaded piles:

- ξ_1 on the mean values of the measured resistances in static load tests;
- ξ_2 on the minimum value of the measured resistances in static load tests;
- ξ_3 on the mean values of the calculated resistances from ground test results;
- ξ_4 on the minimum value of the calculated resistances from ground test results;
- ξ_5 on the mean values of the measured resistances in dynamic load tests;
- ξ_6 on the minimum value of the measured resistances in dynamic load tests.

NOTE The values to be ascribed to ξ_1 , ξ_2 , ξ_3 , ξ_4 , ξ_5 and ξ_6 for use in a country may be found in its National annex to this standard. The recommended values are given in Table A.9, in Table A.10 and in Table A.11.

Table A.9 - Correlation factors ξ to derive characteristic values from static pile load tests (n - number of tested piles)

ξ for $n =$	1	2	3	4	≥ 5
ξ_1	1,40	1,30	1,20	1,10	1,00
ξ_2	1,40	1,20	1,05	1,00	1,00

Table A.10 - Correlation factors ξ to derive characteristic values from ground test results (n - the number of profiles of tests)

ξ for $n =$	1	2	3	4	5	7	10
ξ_3	1,40	1,35	1,33	1,31	1,29	1,27	1,25
ξ_4	1,40	1,27	1,23	1,20	1,15	1,12	1,08

Table A.11 - Correlation factors ξ to derive characteristic values from dynamic impact tests^{a, b, c, d, e} (n - number of tested piles)

ξ for $n =$	≥ 2	≥ 5	≥ 10	≥ 15	≥ 20
ξ_5	1,60	1,50	1,45	1,42	1,40
ξ_6	1,50	1,35	1,30	1,25	1,25

^a The ξ -values in the table are valid for dynamic impact tests.

^b The ξ -values may be multiplied with a model factor of 0,85 when using dynamic impact tests with signal matching.

^c The ξ -values should be multiplied with a model factor of 1,10 when using a pile driving formula with measurement of the quasi-elastic pile head displacement during the impact.

^d The ξ -values shall be multiplied with a model factor of 1,20 when using a pile driving formula without measurement of the quasi-elastic pile head displacement during the impact.

^e If different piles exist in the foundation, groups of similar piles should be considered separately when selecting the number n of test piles.

A.3.3.4 \square_{A1} Partial resistance factors for anchors \square_{A1}

\square_{A1} (1) See A.6. \square_{A1}

Table A.12 – \square_{A1} Table A.12 – Not used \square_{A1}

A.3.3.5 Partial resistance factors (γ_R) for retaining structures

(1)P For retaining structure and verifications of structural (STR) and geotechnical (GEO) limit states, set *R1*, *R2* or *R3* of the following partial factors on resistance (γ_R) shall be applied :

- $\gamma_{R,v}$ on bearing capacity;
- $\gamma_{R,h}$ on sliding resistance;
- $\gamma_{R,e}$ on earth resistance.

NOTE The values to be ascribed to $\gamma_{R,v}$, $\gamma_{R,h}$ and $\gamma_{R,e}$ for use in a country may be found in its National annex to this standard. The recommended values for the three sets *R1*, *R2* and *R3* are given in Table A.13.

Table A.13 - Partial resistance factors (γ_R) for retaining structures

Resistance	Symbol	Set		
		<i>R1</i>	<i>R2</i>	<i>R3</i>
Bearing capacity	$\gamma_{R,v}$	1,0	1,4	1,0
Sliding resistance	$\gamma_{R,h}$	1,0	1,1	1,0
Earth resistance	$\gamma_{R,e}$	1,0	1,4	1,0

A.3.3.6 Partial resistance factors (γ_R) for slopes and overall stability

(1)P For slopes and overall stability and verifications of structural (STR) and geotechnical (GEO) limit states a partial factor on ground resistance ($\gamma_{R,e}$) shall be applied.

NOTE The value to be ascribed to $\gamma_{R,e}$ for use in a country may be found in its National annex to this standard. The recommended value for the three sets *R1*, *R2* and *R3* is given in Table A.14.

Table A.14 - Partial resistance factors (γ_R) for slopes and overall stability

Resistance	Symbol	Set		
		<i>R1</i>	<i>R2</i>	<i>R3</i>
Earth resistance	$\gamma_{R,e}$	1,0	1,1	1,0

A.4 Partial factors for uplift limit state (UPL) verifications

(1)P For the verification of uplift limit state (UPL) the following partial factors on actions (γ_f) shall be applied:

- $\gamma_{G;dst}$ on destabilising unfavourable permanent actions;
- $\gamma_{G;stb}$ on stabilising favourable permanent actions;
- $\gamma_{Q;dst}$ on destabilising unfavourable variable actions.

NOTE The values to be ascribed to $\gamma_{G;dst}$, $\gamma_{G;stb}$ and $\gamma_{Q;dst}$ for use in a country may be found in its National annex to this standard. The recommended values are given in Table A.15.

Table A.15 - Partial factors on actions (γ_f)

Action	Symbol	Value
Permanent		
Unfavourable ^a	$\gamma_{G;dst}$	1,0
Favourable ^b	$\gamma_{G;stb}$	0,9
Variable		
Unfavourable ^a	$\gamma_{Q;dst}$	1,5
^a Destabilising;		
^b Stabilising		

(2)P For the verification of uplift limit state (UPL) the following partial factors shall be applied when including resistances:

- $\gamma_{\phi'}$ on the tangent of the angle of shearing resistance;
- γ_c on effective cohesion;
- γ_{cu} on undrained shear strength;
- $\gamma_{s;t}$ on tensile pile resistance;
- $\gamma_{a;ULS}$ on ultimate limit state anchor resistance.

NOTE The values to be ascribed to $\gamma_{\phi'}$, γ_c , γ_{cu} , $\gamma_{s;t}$ and $\gamma_{a;ULS}$ for use in a country may be found in its National Annex to this standard. The recommended values are given in Table A.16. A1

Table A.16 - Partial factors for soil parameters and resistances

Soil parameter	Symbol	Value
Angle of shearing resistance ^a	$\gamma_{\varphi'}$	1,25
Effective cohesion	$\gamma_{c'}$	1,25
Undrained shear strength	γ_{cu}	1,40
Tensile pile resistance	$\gamma_{s,t}$	1,40
Ultimate limit state anchor resistance	$\gamma_{a,ULS}$	^b
^a This factor is applied to $\tan \varphi'$ ^b See Table A.19		

A.5 Partial factors for hydraulic heave limit state (HYD) verification

(1)P For the verification of hydraulic heave limit state (HYD) the following partial factors on actions (γ_F) shall be applied:

- $\gamma_{G,dst}$ on destabilising unfavourable permanent actions;
- $\gamma_{G,stb}$ on stabilising favourable permanent actions;
- $\gamma_{Q,dst}$ on destabilising unfavourable variable actions.

NOTE The values to be ascribed to $\gamma_{G,dst}$, $\gamma_{G,stb}$ and $\gamma_{Q,dst}$ for use in a country may be found in its National annex to **AC1** this standard **AC1**. The recommended values are given in Table A.17.

Table A.17 - Partial factors on actions (γ_F)

Action	Symbol	Value
Permanent		
Unfavourable ^a	$\gamma_{G,dst}$	1,35
Favourable ^b	$\gamma_{G,stb}$	0,90
Variable		
Unfavourable ^a	$\gamma_{Q,dst}$	1,50
^a Destabilising ^b Stabilising		

A.6 Partial resistance factors, correlation factors, limiting criteria for ultimate and serviceability limit states, and number of investigation/suitability tests for anchors

(1)P For the verification of actions and action effects for persistent and transient design situations at the ultimate limit state and for serviceability limit states the following partial factor shall be applied:

— γ_{Serv} on $F_{\text{Serv};k}$

NOTE The values to be ascribed to γ_{Serv} for use in a country may be found in its National Annex to this standard. The recommended values are given in Table A.18.

Table A.18 — Partial factors on actions and action effects for persistent and transient design situations at the ultimate limit state

Limit state	Symbol	Value
Ultimate (Formula 8.3)	γ_{Serv}	1,35
NOTE the recommended value of γ_{Serv} applies to all Design Approaches		

(2)P For the verification of anchors in ultimate limit states STR, GEO, and UPL in persistent and transient design situations, the following partial factor shall be applied:

— $\gamma_{a;\text{ULS}}$ on $R_{\text{ULS};k}$

NOTE The values to be ascribed to $\gamma_{a;\text{ULS}}$ for use in a country may be found in its National Annex to this standard. The recommended values are given in Table A.19.

Table A.19 — Partial resistance factors (γ_R) for anchors in ultimate limit states for persistent and transient design situations

Symbol	STR/GEO Set				UPL
	R1	R2	R3	R4	
$\gamma_{a;\text{ULS}}$	1,1	1,1	1,0	1,1	1,4

(3)P For the verification of anchor test methods for persistent and transient design situations at the ultimate limit state and for serviceability limit states the following correlation and partial factors shall be applied:

— ξ_{ULS} on $(R_{\text{ULS};m})_{\text{min}}$

— $\gamma_{a;\text{SLS}}$ on $R_{\text{SLS};k}$

— $\gamma_{a;\text{acc};\text{ULS}}$ on $E_{\text{ULS};d}$

— $\gamma_{a;\text{acc};\text{SLS}}$ on $F_{\text{Serv};k}$

NOTE The values to be ascribed to ξ_{ULS} , $\gamma_{a;\text{SLS}}$, $\gamma_{a;\text{acc};\text{ULS}}$ and $\gamma_{a;\text{acc};\text{SLS}}$ for use in a country may be found in its National Annex to this standard. The recommended values are given in Table A.20. **A1**

Table A.20 — Values depending on anchor test method for persistent and transient design situations at the ultimate limit state and for serviceability limit states

Symbol	Equation	Test method ^a		
		1	2	3
ξ_{ULS}	8.6	1,0 ^b	1,0 ^b	1,0
$\gamma_{a;SLS}$	8.10	NA	1,0	1,2 ^c
n		3	3	2
$\gamma_{a;acc;ULS}$	8.13	1,1	1,1	NA
$\gamma_{a;acc;SLS}$	8.14	NA	1,0	1,25 ^c
NOTE NA = Not Applicable				
^a For a description of the test methods see EN ISO 22477-5.				
^b This value applies provided acceptance tests on every anchor (proof load to Formula 8.13) give assurance that $E_{ULS;d} \leq R_{ULS;d}$. The value of ξ_{ULS} to be used when this is not the case may be set by the National Annex.				
^c Values given are for permanent anchors.				

(4)P For the verification of investigation, suitability and acceptance tests for persistent and transient design situations at the ultimate limit state and for serviceability limit states, the anchor shall satisfy limiting criteria.

NOTE The limiting criteria for use in a country may be found in its National Annex to this standard. The recommended values are given in Table A.21.

Table A.21 — Limiting criteria for investigation, suitability and acceptance tests for persistent and transient design situations at the ultimate and serviceability limit states

Test Method ^a	Limiting criterion	Investigation and suitability tests		Acceptance tests	
		ULS (Formula 8.5)	SLS (Formula 8.8)	ULS (Formula 8.13)	SLS (Formula 8.14)
1	α_1	2 mm	0,01 Δe ^c /NA ^d	2 mm	0,01 Δe ^c /NA ^d
2 ^b	k_1	2 % per log cycle of time	2 % per log cycle of time	2 % per log cycle of time	2 % per log cycle of time
3	α_3	5 mm	NA (use P_c)	NA	1,5 mm ^e
NOTE NA = Not Applicable					
^a For a description of the test methods see EN ISO 22477-5.					
^b Times of observation for load loss in accordance with Table H.1, Annex H, EN ISO 22477-5					
^c $\Delta e = (F_{serv;k} \times \text{tendon free length}) / (\text{area of tendon} \times \text{elastic modulus of tendon})$					
^d Value is only applicable when SLS-testing is undertaken					
^e Value given is for permanent anchors; for temporary anchors, $\alpha_3 = 1.8$ mm					

A1

Annex B (informative)

Background information on partial factors for Design Approaches 1, 2 and 3

B.1 General

(1) For limit state types STR and GEO in persistent and transient situations, three Design Approaches are outlined in 2.4.7.3.4. They differ in the way they distribute partial factors between actions, the effects of actions, material properties and resistances. In part, this is due to differing approaches to the way in which allowance is made for uncertainties in modelling the effects of actions and resistances.

(2) In Design Approach 1, for all designs, checks are, in principle, required for two sets of factors, applied in two separate calculations. Where it is obvious that one of these sets governs the design, it will not be necessary to carry out calculations for the other set. Generally, factors are applied to actions, rather than to the effects of actions, though with one noted exception (2.4.7.3.2(2)). In many cases, factors are applied to ground parameters, but for the design of piles and anchors they are applied to resistances.

(3) In Design Approaches 2 and 3, a single calculation is required for each part of a design, and the way in which the factors are applied is varied according to the calculation considered.

(4) In Design Approach 2, factors are applied either to actions or the effects of actions and to resistances.

(5) In Design Approach 3, factors are applied to actions or the effects of actions from the structure and to ground strength (material) parameters.

B.2 Factors on actions and the effects of actions

(1) EN 1990:2002 states that γ_f is a partial factor for an action and takes account of the possibility of unfavourable deviations of the action value from its characteristic value. Likewise $\gamma_{S;d}$ is a partial factor taking account of uncertainties in modelling the actions and in modelling the effects of actions.

(2) EN 1990:2002 allows $\gamma_{S;d}$ and γ_f to be combined into one factor multiplying F_k :

$$\gamma_F = \gamma_{S;d} \cdot \gamma_f \quad (\text{B.1})$$

(3) The various approaches in EN 1997-1 require that factors be applied either to actions or the effects of actions. Since the use of model factors $\gamma_{S;d}$ for actions from the ground will remain exceptional and is therefore left to national determination, γ_f is used throughout for simplicity for actions and γ_E for the effects of actions in geotechnical design (see Annex A, Tables A.1 and A.3).

This enables national authorities to select alternative values of the combination $\gamma_{S;d} \times \gamma_f$

(4) $\overline{AC_1}$ Equations (2.6a) and (2.6b) include $\overline{AC_1} X_k/\gamma_M$ in the calculation of actions because ground material properties may affect the values of geotechnical actions in some cases.

(5) In Design Approach 1, checks are required for two combinations of sets of factors, applied in two separate calculations.

In Combination 1, factors unequal to 1 are generally applied to actions, with factors equal to 1 on the effects of actions. Thus $\gamma_F \neq 1$ and $\gamma_E = 1$ are applied in $\boxed{\text{AC1}}$ equations (2.6a) and (2.6b) $\boxed{\text{AC1}}$.

An exception to this is noted in 2.4.7.3.2(2): in cases where it would be physically unreasonable to apply $\gamma_F \neq 1$ (example: tank with fixed fluid level), then $\gamma_F = 1$ and $\gamma_E \neq 1$ are used.

In Combination 2, $\gamma_E = 1$ is always used, with $\gamma_F \neq 1$ only for variable actions.

Thus, except as noted in 2.4.7.3.2(2), for Design Approach 1 $\boxed{\text{AC1}}$ equation (2.6a) applies $\boxed{\text{AC1}}$

$$E_d = E\{\gamma_F F_{\text{rep}}; X_k / \gamma_M; a_d\} \quad (\text{B.2}).$$

(6) In Design Approach 2, a single calculation is required for each part of a design, and the way in which the factors are applied either to actions or the effects of actions is varied according to the calculation considered and chosen according to national determination.

Either $\gamma_E \neq 1$ and $\gamma_F = 1$, or $\gamma_F \neq 1$ and $\gamma_E = 1$ are applied. Since $\gamma_M = 1$ is used, $\boxed{\text{AC1}}$ equations (2.6a) and (2.6b) reduce to: $\boxed{\text{AC1}}$

$$E_d = \gamma_E \cdot E\{F_{\text{rep}}; X_k; a_d\}, \text{ or,} \quad (\text{B.3.1})$$

$$E_d = E\{\gamma_F F_{\text{rep}}; X_k; a_d\} \quad (\text{B.3.2})$$

(7) In Design Approach 3, a single calculation is required. However, in this Design Approach a difference is made between actions F_{rep} from the structure and actions from or through the ground calculated from X_k . Either $\gamma_E \neq 1$ and $\gamma_F = 1$ or $\gamma_E = 1$ and $\gamma_F \neq 1$ are applied. Thus $\boxed{\text{AC1}}$ equations (2.6a) and (2.6b) remain: $\boxed{\text{AC1}}$

$$E_d = E\{\gamma_F F_{\text{rep}}; X_k / \gamma_M; a_d\}, \text{ or,} \quad (\text{B.4.1})$$

$$E_d = \gamma_E E\{F_{\text{rep}}; X_k / \gamma_M; a_d\} \quad (\text{B.4.2})$$

B.3 Factors on material strengths and resistances

(1) Equation (6.6) of EN 1990:2002 and $\boxed{\text{AC1}}$ equation (2.7c) $\boxed{\text{AC1}}$ of EN 1997-1 are equivalent:

$$R_d = \frac{1}{\gamma_{R;d}} R\{X_{i;d}; a_d\} = \frac{1}{\gamma_{R;d}} R\left\{\eta_i \frac{X_{i;k}}{\gamma_{m;i}}; a_d\right\} \quad (\text{EN 1990:2002, equation 6.6}) \quad (\text{B.5.1})$$

$$R_d = \frac{1}{\gamma_R} \left\{ \gamma_F F_{\text{rep}}; \frac{X_k}{\gamma_M}; a_d \right\}, \quad (\text{EN 1997-1, } \boxed{\text{AC1}} \text{ equation 2.7c } \boxed{\text{AC1}}) \quad (\text{B.5.2})$$

(2) Note that EN 1997-1, $\boxed{\text{AC1}}$ equations (2.7a), (2.7b) and (2.7c) $\boxed{\text{AC1}}$, includes $\gamma_F F_{\text{rep}}$ in the calculation of design resistances because the magnitudes of actions may affect the values of geotechnical resistances in some cases, e.g. bearing capacity of a shallow foundation.

(3) The value of the conversion factor η is taken to be 1,0 in EN 1997-1 because the characteristic material strengths are defined to be those relevant to the field situation, thereby including η in the characteristic value.

(4) The various approaches in this standard require that factors be applied either to material strengths (X) or to resistances (R). These factors combine the roles of the material factors γ_m and the resistance model factors ($\gamma_{R;d}$) in various ways. For simplicity, the factors applied to material strengths (X) are denoted (γ_M), and the factors applied to resistances (R) are denoted γ_R .

(5) In Design Approach 1, checks are required for combinations of sets of factors for two separate calculations.

In Combination 1, factors equal to 1 are applied to material strength and resistances. Thus $\gamma_M = \gamma_R = 1$ in $\boxed{\text{AC1}}$ equation (2.7c) $\boxed{\text{AC1}}$.

In Combination 2, except for piles and $\boxed{\text{A1}}$ anchors $\boxed{\text{A1}}$, $\gamma_M > 1$, $\gamma_R = 1$.

Thus in most cases Design Approach 1 adopts Equation (2.7a):

$$R_d = R\{\gamma_F F_{\text{rep}}; X_k/\gamma_M; a_d\} \quad (\text{B.6.1.1})$$

But, in Combination 2 for piles and anchors, $\gamma_M = 1$ and $\gamma_R > 1$ are used in equation (2.7b) thus:

$$R_d = \frac{1}{\gamma_R} R\{\gamma_F F_{\text{rep}}; X_k; a_d\} \quad (\text{B.6.1.2})$$

(6) In Design Approach 2, factors equal to 1 are generally applied to material strengths, with factors greater than 1 applied to resistances. Thus $\gamma_M = 1$; $\gamma_R > 1$ are used in equation (2.7b):

$$R_d = \frac{1}{\gamma_R} R\{\gamma_F F_{\text{rep}}; X_k; a_d\} \quad (\text{B.6.2.1})$$

When $\gamma_F = 1$ is also used, equation (2.7b) is used under the form:

$$R_d = \frac{1}{\gamma_R} R\{F_{\text{rep}}; X_k; a_d\} \quad (\text{B.6.2.2})$$

(7) In Design Approach 3, $\gamma_M > 1$ and $\gamma_R = 1$ are generally applied. Equation (2.7a) is used thus:

$$R_d = R\{\gamma_F F_{\text{rep}}; X_k/\gamma_M; a_d\} \quad (\text{B.6.3.1})$$

But, note that sometimes there is also a need to have $\gamma_R > 1$ (piles in tension, for example), so that equation (2.7a) is used thus:

$$R_d = R\{\gamma_F F_{\text{rep}}; X_k/\gamma_M; a_d\} / \gamma_R \quad (\text{B.6.3.2})$$

Annex C
(informative)

Sample procedures to determine earth pressures

C.1 Limit values of earth pressure

(1) The limit values of earth pressure on a vertical wall, caused by soil of weight density (γ), uniform vertical surface load (q), angle of shearing resistance (ϕ) and cohesion (c) should be calculated as follows:

— active limit state:

$$\sigma_a(z) = K_a \left[\int \gamma dz + q - u \right] + u - c K_{ac} \quad (\text{C.1})$$

where the integration is taken from ground surface to depth z

$$K_{ac} = 2\sqrt{[K_a(1+a/c)]}, \text{ limited to } 2,56\sqrt{K_a}$$

— passive limit state:

$$\sigma_p(z) = K_p \left[\int \gamma dz + q - u \right] + u + c K_{pc} \quad (\text{C.2})$$

where the integration is taken from ground surface to depth z

$$K_{pc} = 2\sqrt{[K_p(1+a/c)]}, \text{ limited to } 2,56\sqrt{K_p}$$

where:

- a is the adhesion (between ground and wall)
- c is the cohesion
- K_a is the coefficient of effective horizontal active earth pressure
- K_p is the coefficient of effective horizontal passive earth pressure
- q is the vertical surface load
- z is the distance down the face of the wall
- β is the slope angle of the ground behind the wall (upward positive)
- δ is the angle of shearing resistance between ground and wall
- γ is the total weight density of retained ground
- $\sigma_a(z)$ is the total stress normal to the wall at depth z (active limit state)
- $\sigma_p(z)$ is the total stress normal to the wall at depth z (passive limit state)

(2) For drained soil, K_a and K_p are functions of angle of shearing resistance ϕ' , and $c = c'$, the effective cohesion. For undrained soil, $K_a = K_p = 1$ and $c = c_u$, the undrained shear strength. AC1

AC1 (3) Values of the effective earth pressure coefficients may be taken from Figures C.1.1 to C.1.4 for K_a and C.2.1 to C.2.4 for K_p .

(4) Alternatively, the analytical procedure described in C.2 may be used.

(5) In layered soils, the coefficients K should normally be determined by the shear strength parameters at depth z only, independent of the values at other depths.

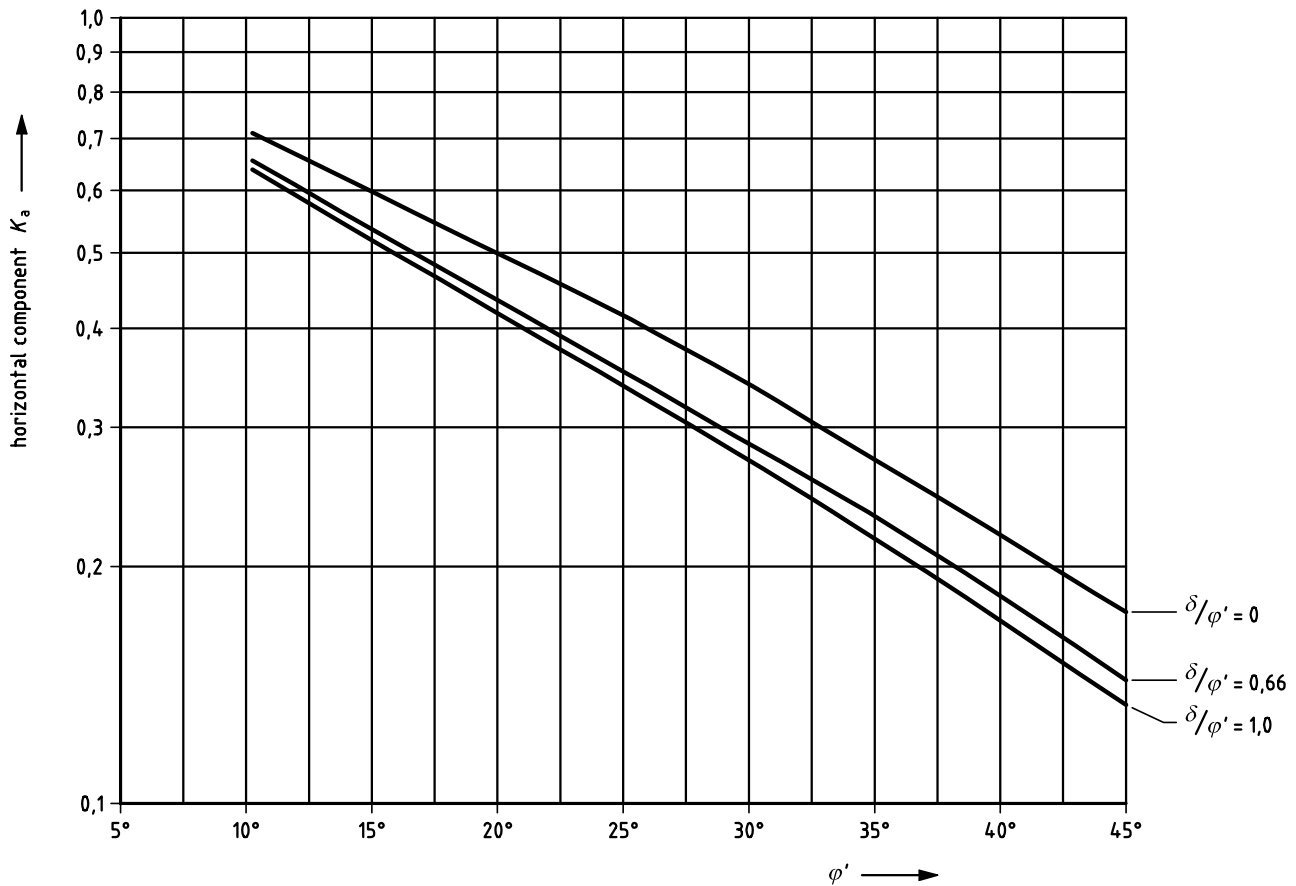
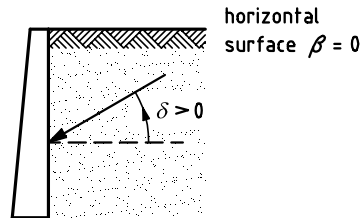

Figure C.1.1 — Coefficients K_a of effective active earth pressure (horizontal component): with horizontal retained surface ($\beta = 0$) **AC1**

AC1

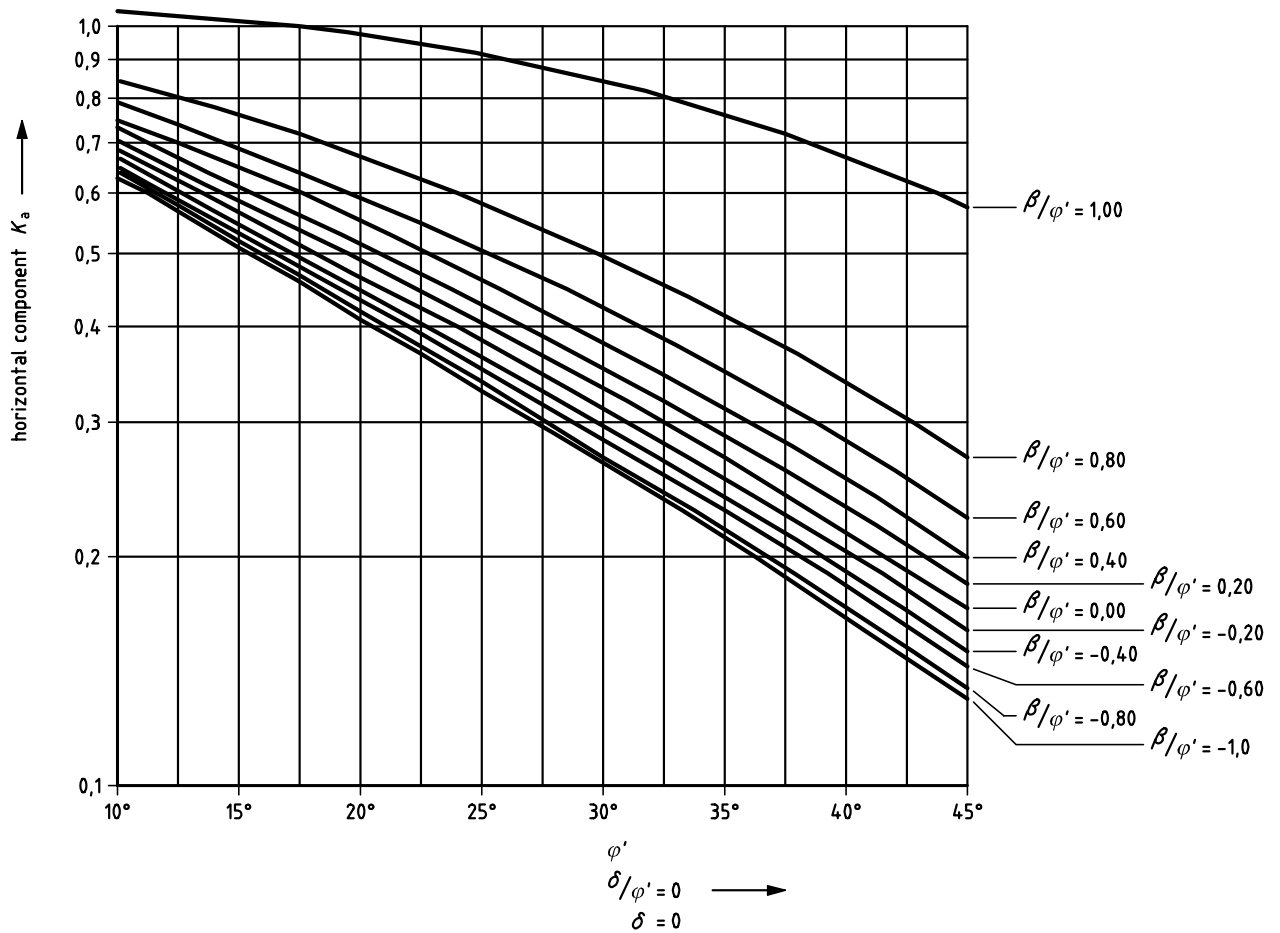
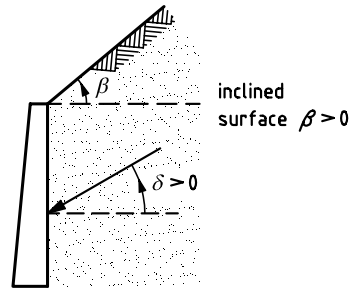

Figure C.1.2 — Coefficients K_a of effective active earth pressure (horizontal component): with inclined retained surface ($\delta/\phi' = 0$ and $\delta = 0$) AC1

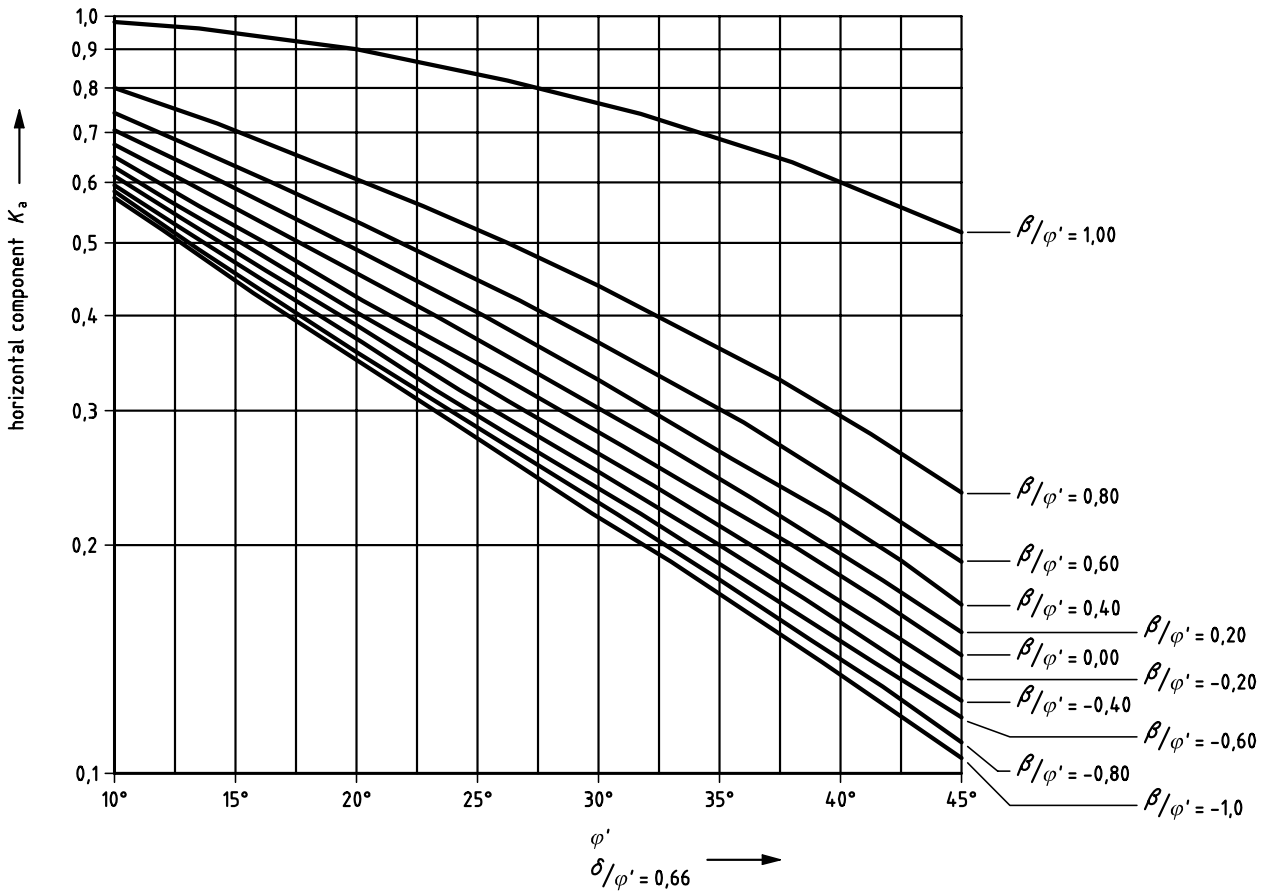
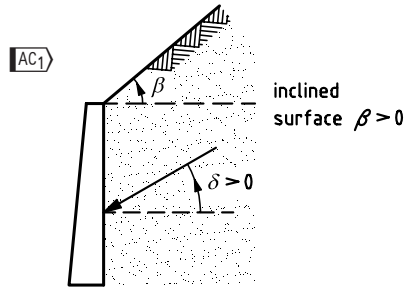

Figure C.1.3 — Coefficients K_a of effective active earth pressure (horizontal component): with inclined retained surface ($\delta/\phi' = 0,66$) AC1

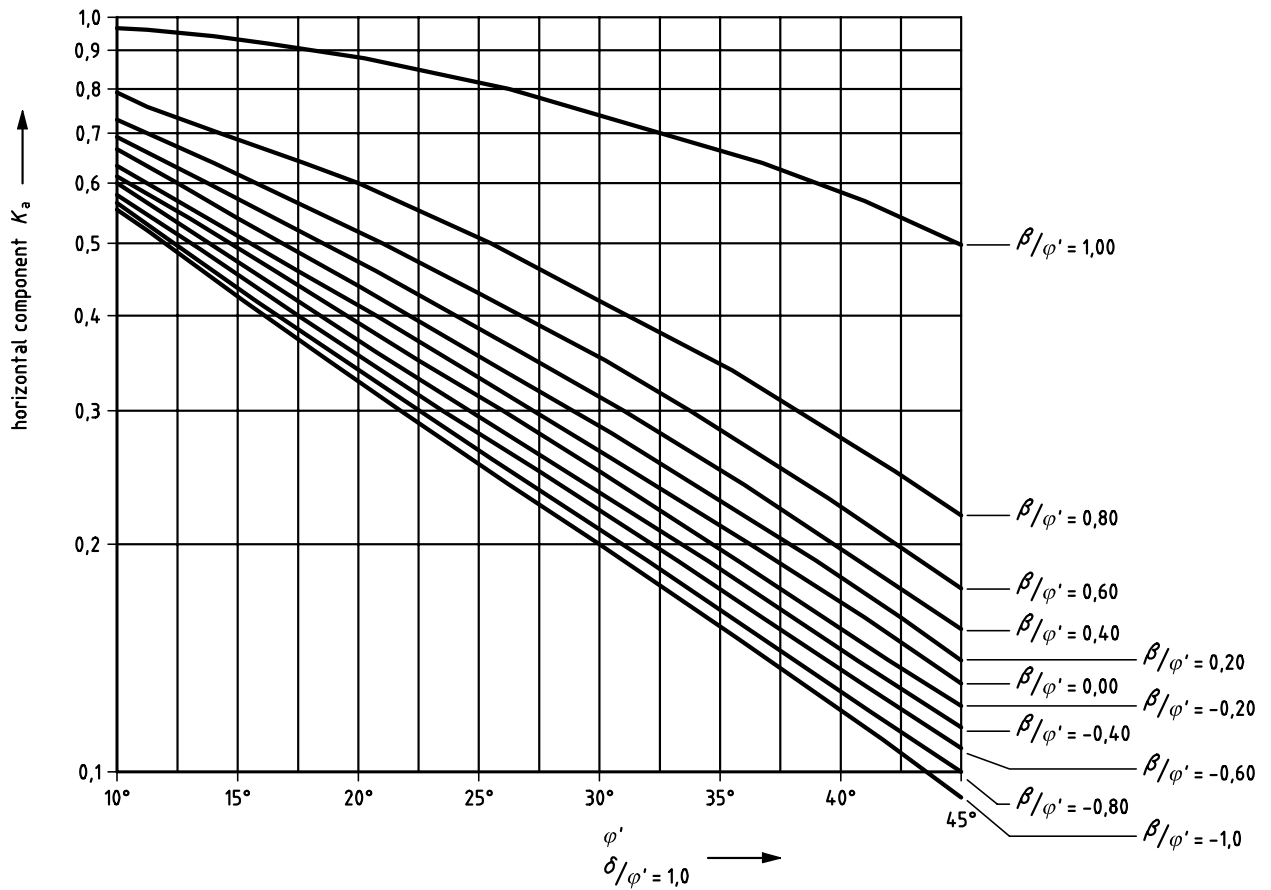
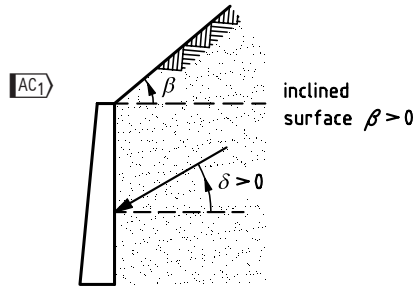

Figure C.1.4 — Coefficients K_a of effective active earth pressure (horizontal component): with inclined retained surface ($\delta/\phi' = 1$) AC1

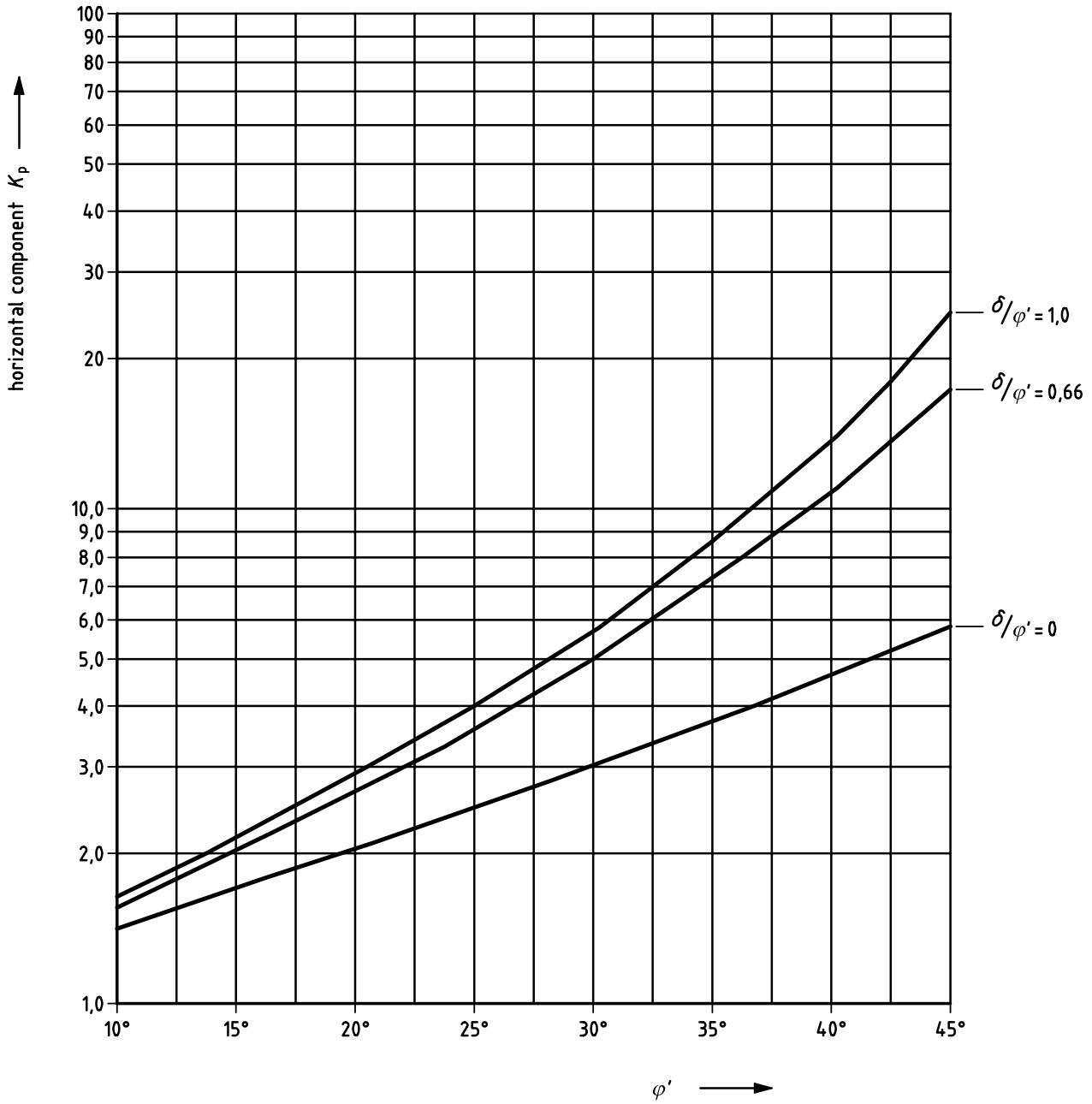
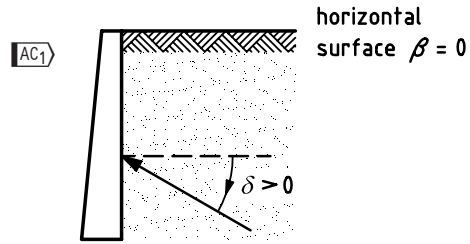

Figure C.2.1 — Coefficients K_p of effective passive earth pressure (horizontal component): with horizontal retained surface ($\beta = 0$) AC1

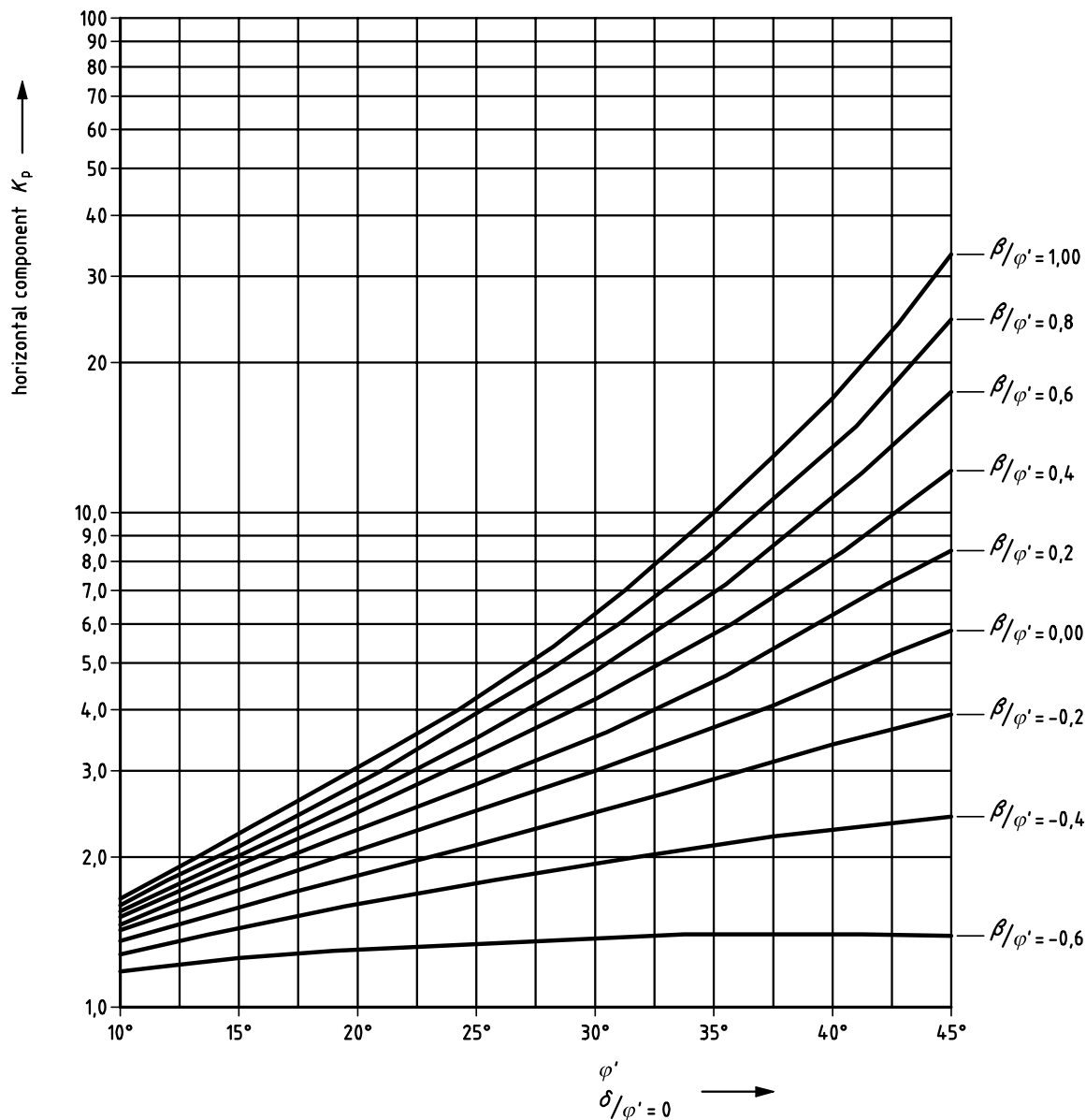
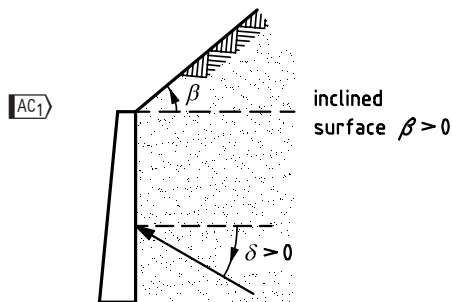

Figure C.2.2 — Coefficients K_p of effective passive earth pressure (horizontal component): with inclined retained surface ($\delta/\phi' = 0$ and $\delta = 0$) AC1

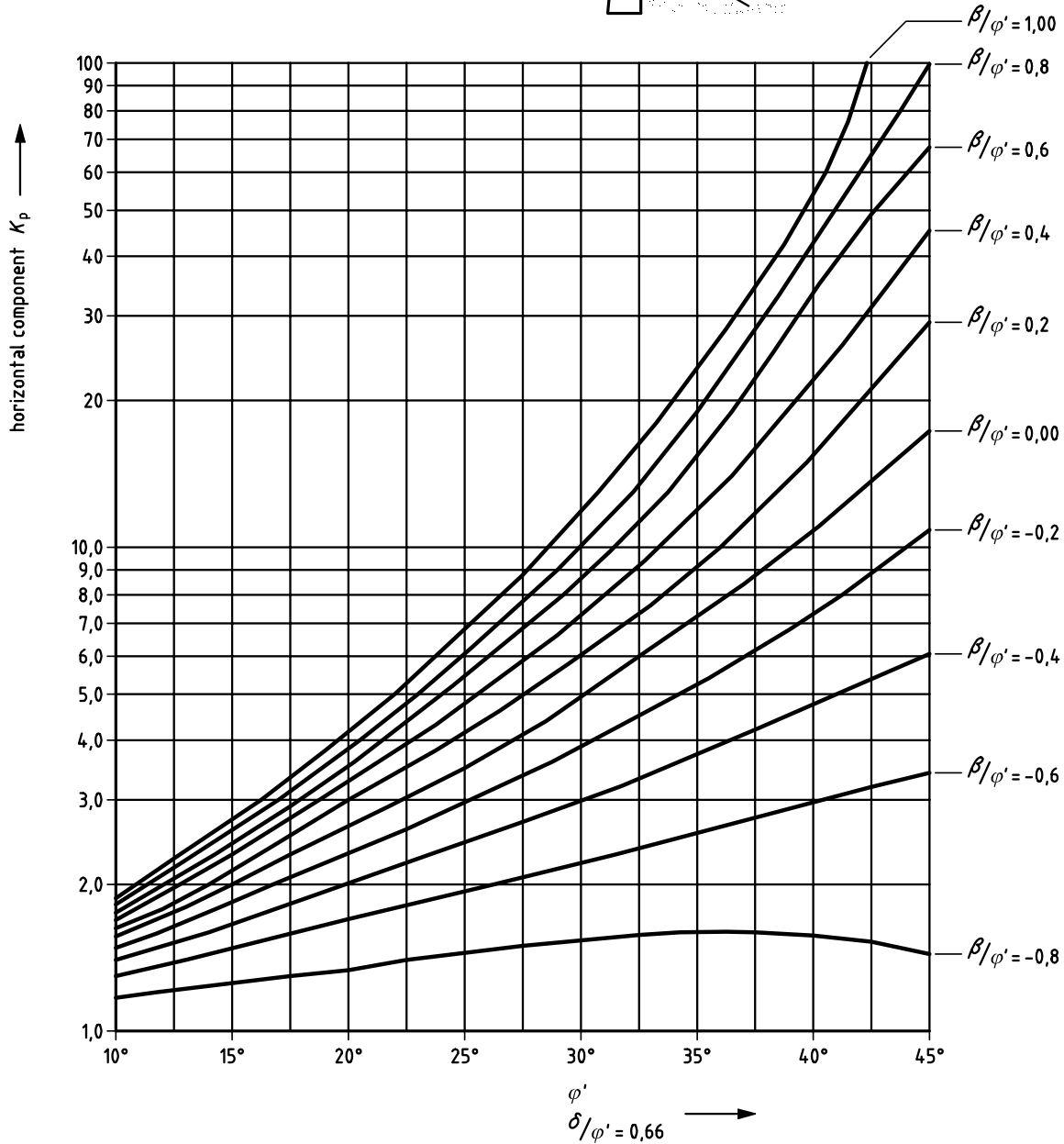
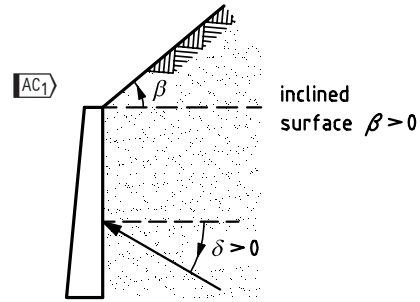

Figure C.2.3 — Coefficients K_p of effective passive earth pressure (horizontal component): with inclined retained surface ($\delta/\phi' = 0,66$) AC1

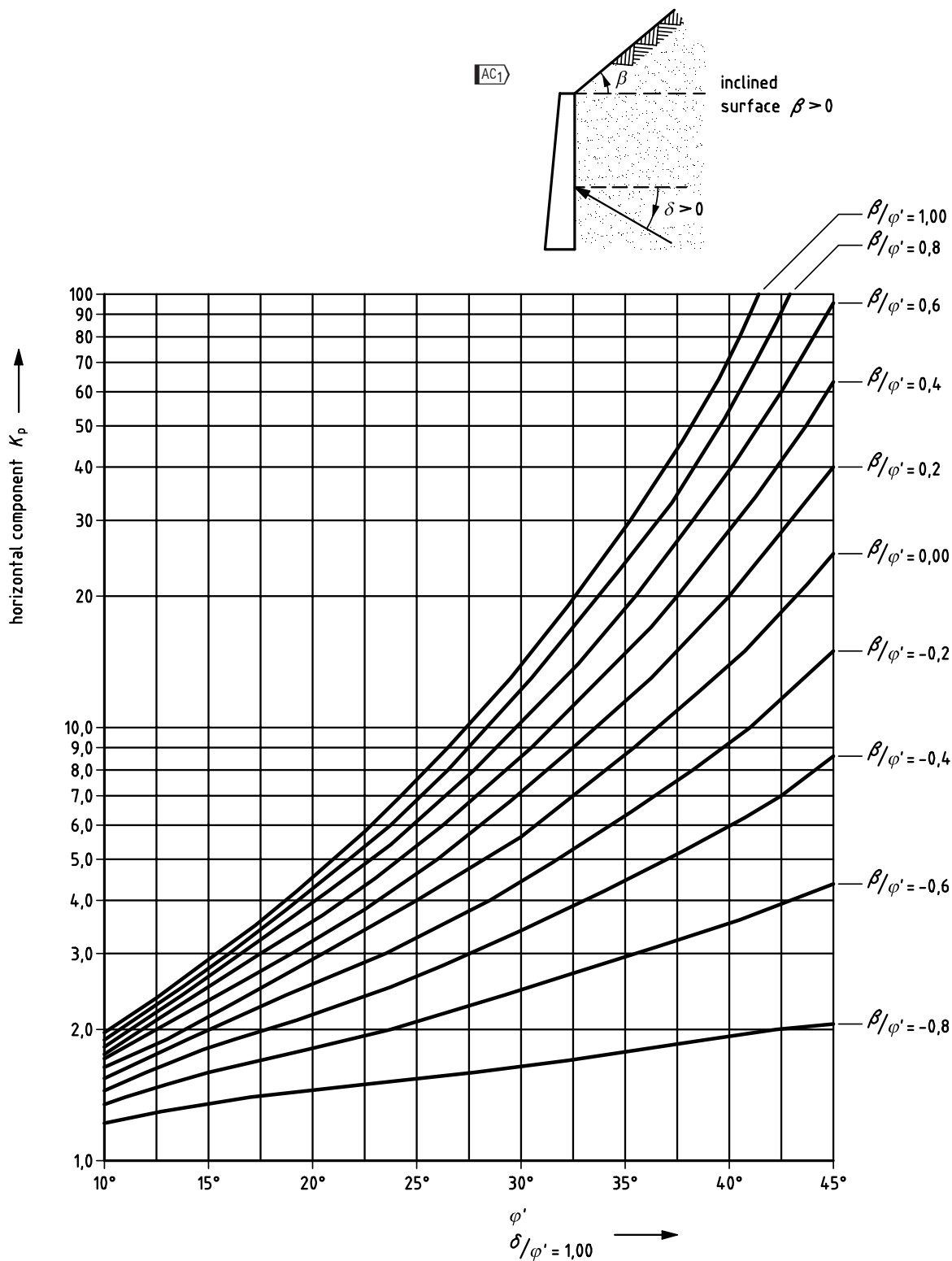

Figure C.2.4 — Coefficients K_p of effective passive earth pressure (horizontal component): with inclined retained surface ($\delta/\varphi' = 1$) AC_1

AC1 C.2 Analytical procedure for obtaining limiting active and passive earth pressures

- (1) The following procedure, which includes certain approximations, may be used in all cases.
- (2) The procedure is stated for passive pressures with the strength parameters (represented in the following by φ , c , δ , a) inserted as positive values, see Figure C.3.
- (3) For active pressures the same algorithm is used, with the following changes:
- the strength parameters φ , c , δ and a are inserted as negative values;
 - the value of the angle of incidence of the equivalent surface load β_0 is β , mainly because of the approximations used for K_γ .
- (4) The following symbols are used (some are also given in 1.6):

a	is the adhesion between wall and ground
c	is the cohesion
K_c	is the coefficient for cohesion
K_n	is the coefficient for normal loading on the surface
K_q	is the coefficient for vertical loading
K_γ	is the coefficient for the soil weight
m_t	is the angle from the soil surface direction, pointing away from the wall, to the tangent direction of the intersecting slip line that bounds the moving soil mass, pointing out from the soil surface
m_w	is the angle from the wall normal to the tangent direction at the wall of the exterior slip line, positive when the tangent points upwards behind the wall
β	is the angle from the horizontal to the soil surface direction, positive when the soil surface rises away from the wall
δ	is the angle of wall friction, with sign convention as defined in Figure C.4 when computing passive resistance
φ	is the angle of shearing resistance
θ	is the angle between the vertical and the wall direction, positive when the soil overhangs the wall
ν	is the tangent rotation along the exterior slip line, positive when the soil mass above this slip line is of a convex shape
q	is the general uniform surcharge pressure, per unit area of the actual surface
p	is the vertical uniform surcharge pressure, per unit area in a horizontal projection AC1

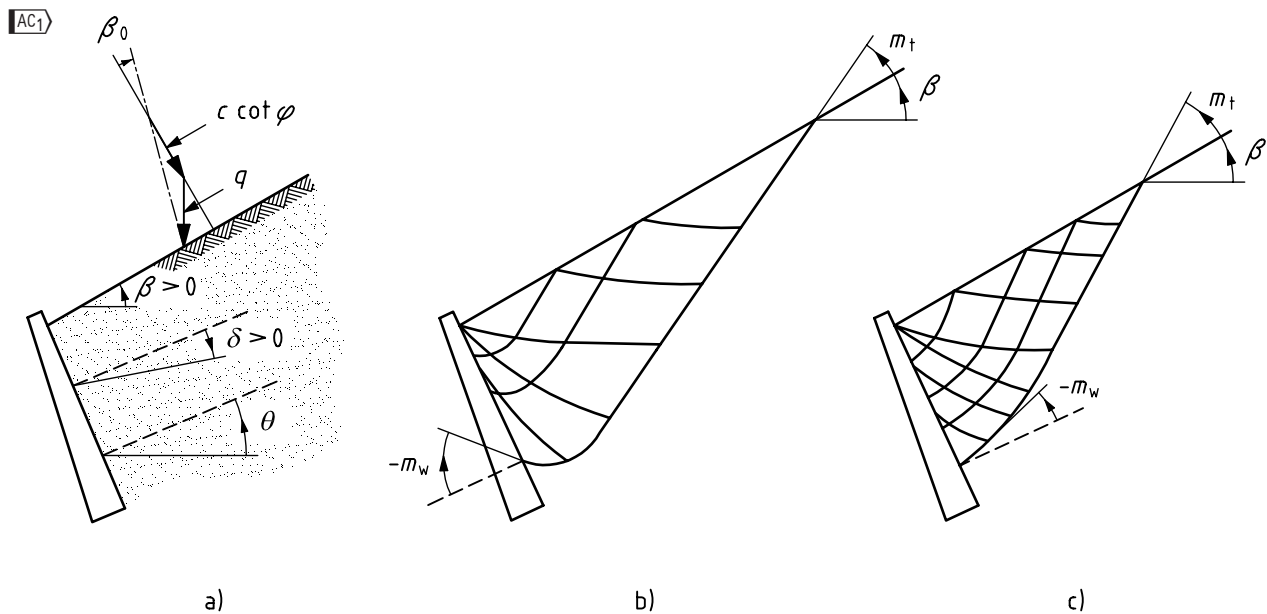

Figure C.3 — Definitions concerning wall and backfill inclination, surcharges and slipline geometry

(5) The interface parameters δ and a must be chosen so that:

$$\frac{a}{c} = \frac{\tan \delta}{\tan \varphi}$$

(6) The boundary condition at the soil surface involves β_0 , which is the angle of incidence of an equivalent surface load. With this concept the angle is defined from the vectorial sum of two terms:

- actual distributed surface loading q , per unit of surface area, uniform but not necessarily vertical, and;
- $c \cot \varphi$ acting as normal load.

The angle β_0 is positive when the tangential component of q points toward the wall while the normal component is directed toward the soil. If $c = 0$ while the surface load is vertical or zero, and for active pressures generally, $\beta_0 = \beta$.

(7) The angle m_t is determined by the boundary condition at the soil surface:

$$\cos(2m_t + \varphi + \beta_0) = -\frac{\sin \beta_0}{\sin \varphi} \quad (\text{C.3})$$

(8) The boundary condition at the wall determines m_w by:

$$\cos(2m_w + \varphi + \delta) = \frac{\sin \delta}{\sin \varphi} \quad (\text{C.4})$$

The angle m_w is negative for passive pressures ($\varphi > 0$) if the ratio $\sin \delta / \sin \varphi$ is sufficiently large.

(9) The total tangent rotation along the exterior slip line of the moving soil mass, is determined by the angle ν to be computed by the expression: $\langle \text{AC1} \rangle$

$$\boxed{\text{AC1}} \nu = m_t + \beta - m_w - \theta \quad (\text{C.5})$$

(10) The coefficient K_n for normal loading on the surface (i.e. the normal earth pressure on the wall from a unit pressure normal to the surface) is then determined by the following expression in which ν is to be inserted in radians:

$$K_n = \frac{1 + \sin \varphi \sin(2m_w + \varphi)}{1 - \sin \varphi \sin(2m_t + \varphi)} \exp(2\nu \tan \varphi) \quad (\text{C.6})$$

(11) The coefficient for a vertical loading on the surface (force per unit of horizontal area projection), is:

$$K_q = K_n \cos^2 \beta \quad (\text{C.7})$$

and the coefficient for the cohesion term is:

$$K_c = (K_n - 1) \cot \varphi \quad (\text{C.8})$$

(12) For the soil weight an approximate expression is:

$$K_\gamma = K_n \cos \beta \cos(\beta - \theta) \quad (\text{C.9})$$

This expression is on the safe side. While the error is unimportant for active pressures it may be considerable for passive pressures with positive values of β .

For $\varphi = 0$ the following limit values are found:

$$\cos 2m_t = -\frac{p}{c} \sin \beta \cos \beta;$$

$$\cos 2m_w = \frac{a}{c};$$

$$K_q = \cos^2 \beta;$$

$$K_c = 2\nu + \sin 2m_t + \sin 2m_w;$$

(with ν in radians), while for K_γ ($\varphi = 0$), a better approximation is:

$$K_\gamma = \cos \theta + \frac{\sin \beta \cos m_w}{\sin m_t} \quad (\text{C.10})$$

(13) Both for passive and active pressures, the procedure assumes the angle of convexity to be positive ($\nu \geq 0$).

(14) If this condition is not (even approximately) fulfilled, e.g. for a smooth wall and a sufficiently sloping soil surface when β and φ have opposite signs, it may be necessary to consider using other methods. This may also be the case when irregular surface loads are considered. $\boxed{\text{AC1}}$

AC1 C.3 Movements to mobilise earth pressures

(1) The relationship of earth pressures to wall movement should be considered for active situations. The magnitude of this movement depends on the mode of wall movement, the initial earth pressures and the density of the soil. Table C.1 gives approximate values for the ratio v_a/h for fully mobilised effective active earth pressure for a vertical wall with drained, non-cohesive soil and a horizontal ground surface, assuming an initial stress state with $K_0 < 1$.

(2) The relationship of earth pressures to wall movement should be considered for passive situations. The magnitude of this movement depends on the mode of wall movement, the initial earth pressures and the density of the soil. Table C.2 gives approximate values for the ratio v_p/h for fully mobilised effective passive earth pressure for a vertical wall with drained, non-cohesive soil and a horizontal ground surface, assuming an initial stress state with $K_0 < 1$. Values in brackets are the v/h ratios for half the limiting value of the effective passive earth pressure.

(3) Intermediate values of effective active earth pressure between the rest state and the limit state may be obtained by linear interpolation.

(4) For passive situations, values may be interpolated from those given in Table C.2 using a curve of the general form shown in Figure C.4. **AC1**

AC1

Table C.1 — Ratios v_a/h for non-cohesive soils

Kind of wall movement		v_a/h loose soil %	v_a/h dense soil %
a)		0,4 to 0,5	0,1 to 0,2
b)		0,2	0,05 to 0,1
c)		0,8 to 1,0	0,2 to 0,5
d)		0,4 to 0,5	0,1 to 0,2
where: v_a is the wall motion to mobilise active earth pressure h is the height of the wall			

AC1

Table C.2 — Ratios v_p/h and v/h for $0.5\sigma_p$ for non-cohesive soils

AC1

Mode of wall movement		v_p/h (v/h for $0.5\sigma_p$)	v_p/h (v/h for $0.5\sigma_p$)
		%	%
		loose soil	dense soil
a)		7 (1,5) to 25 (4,0)	5 (1,1) to 10 (2,0)
b)		5 (0,9) to 10 (1,5)	3 (0,5) to 6 (1,0)
c)		6 (1,0) to 15 (1,5)	5 (0,5) to 6 (1,3)

where:

v is the wall displacement

v_p is the wall displacement to mobilise passive earth pressure

h is the height of the wall

σ_p is fully mobilised passive earth pressure

AC1

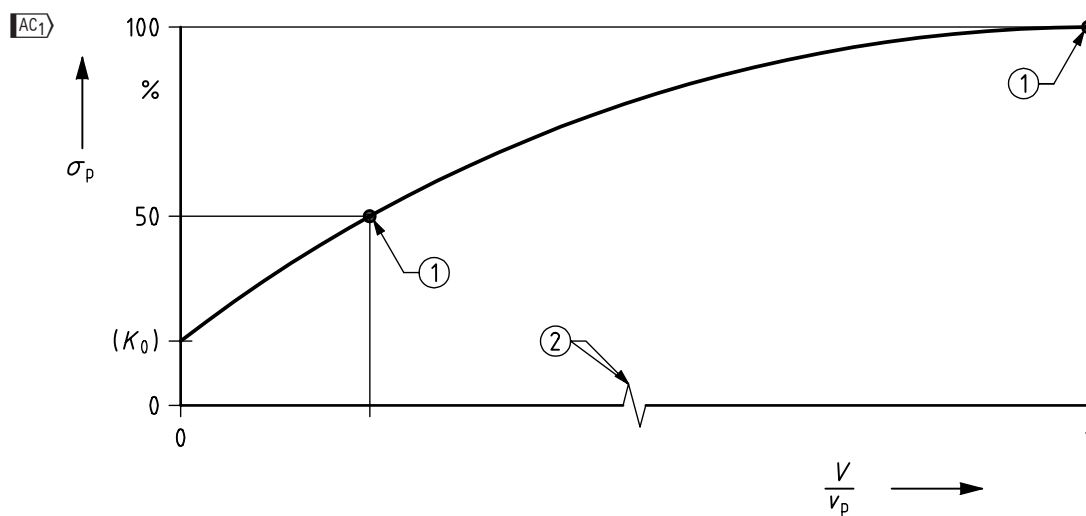

Key

- 1 values taken from Table C.2
- 2 not to scale

Figure C.4 — Mobilisation of effective passive earth pressure of non-cohesive soil versus normalised wall displacement v/v_p
 (v : displacement; v_p : displacement for the full mobilisation of passive earth pressure) AC1

Annex D (informative)

A sample analytical method for bearing resistance calculation

D.1 Symbols used in Annex D

(1) The following symbols are used in Annex D.

$A' = B' \times L'$ the design effective foundation area

b the design values of the factors for the inclination of the base, with subscripts c , q and γ

B the foundation width

B' the effective foundation width

D the embedment depth

e the eccentricity of the resultant action, with subscripts B and L

i the inclination factors of the load, with subscripts cohesion c , surcharge q and weight density γ

L the foundation length

L' the effective foundation length

m exponent in formulas for the inclination factor i

N the bearing capacity factors, with subscripts for c , q and γ

q overburden or surcharge pressure at the level of the foundation base

q' the design effective overburden pressure at the level of the foundation base

s the shape factors of the foundation base, with subscripts for c , q and γ

V the vertical load

α the inclination of the foundation base to the horizontal

γ' the design effective weight density of the soil below the foundation level

θ direction angle of H

(2) The notations used in this method are given in Figure D.1.

D.2 General

(1) Approximate equations for the design vertical bearing resistance, derived from plasticity theory and experimental results, may be used. Allowance should be made for the effects of the following:

— the strength of the ground, generally represented by the design values of c_u , c' and ϕ' ;

- eccentricity and inclination of design loads;
- the shape, depth and inclination of the foundation;
- the inclination of the ground surface;
- ground-water pressures and hydraulic gradients;
- the variability of the ground, especially layering.

D.3 Undrained conditions

(1) The design bearing resistance may be calculated from:

$$R/A' = (\pi+2) c_u b_c s_c i_c + q \quad (D.1)$$

with the dimensionless factors for:

- the inclination of the foundation base: $b_c = 1 - 2\alpha / (\pi + 2)$;
- the shape of the foundation:
 - $s_c = 1 + 0,2 (B'/L')$, for a rectangular shape;
 - $s_c = 1,2$, for a square or circular shape.
- the inclination of the load, caused by a horizontal load H :

$$i_c = \frac{1}{2} \left(1 + \sqrt{1 - \frac{H}{A' c_u}} \right)$$

with $H \leq A' c_u$.

D.4 Drained conditions

(1) The design bearing resistance may be calculated from:

$$R/A' = c' N_c b_c s_c i_c + q' N_q b_q s_q i_q + 0,5 \gamma' B' N_\gamma b_\gamma s_\gamma i_\gamma \quad (D.2)$$

with the design values of dimensionless factors for:

- the bearing resistance:
 - $N_q = e^{\pi \tan \phi'} \tan^2 (45 + \phi'/2)$
 - $N_c = (N_q - 1) \cot \phi'$
 - $N_\gamma = 2 (N_q - 1) \tan \phi'$, where $\delta \geq \phi'/2$ (rough base)
- the inclination of the foundation base:
 - $b_c = b_q - (1 - b_q) / (N_c \tan \phi')$
 - $b_q = b_\gamma = (1 - \alpha \cdot \tan \phi')^2$
- the shape of foundation:
 - $s_q = 1 + (B' / L') \sin \phi'$, for a rectangular shape;
 - $s_q = 1 + \sin \phi'$, for a square or circular shape;
- $s_\gamma = 1 - 0,3 (B'/L')$, for a rectangular shape;
- $s_\gamma = 0,7$, for a square or circular shape

- $s_c = (s_q \cdot N_q - 1) / (N_q - 1)$ for rectangular, square or circular shape;
- the inclination of the load, caused by a horizontal load H :
 $i_c = i_q - (1 - i_q) / (N_c \cdot \tan \phi)$;
 $i_q = [1 - H / (V + A'c' \cot \phi)]^m$;
 $i_y = [1 - H / (V + A'c' \cot \phi)]^{m+1}$.

where:

$$m = m_B = [2 + (B' / L')] / [1 + (B' / L')] \text{ when } H \text{ acts in the direction of } B';$$

$$m = m_L = [2 + (L' / B')] / [1 + (L' / B')] \text{ when } H \text{ acts in the direction of } L'.$$

In cases where the horizontal load component acts in a direction forming an angle θ with the direction of L' , m may be calculated by:

$$m = m_\theta = m_L \cos^2 \theta + m_B \sin^2 \theta.$$

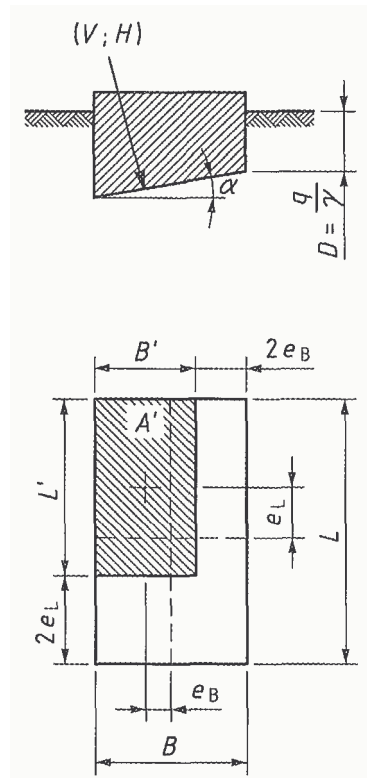

Figure D.1 — Notations

Annex E
(informative)
A sample semi-empirical method for bearing resistance estimation

(1) To estimate the design bearing resistance of a foundation on soil, field tests such as the pressuremeter test may be used.

(2) When using the pressuremeter, the design bearing resistance, R_d , of a foundation subjected to a vertical load is related to the limit pressure of the soil by the linear function:

$$R_d / A' = \sigma_{v,0} + k p_{le}^* \tag{E.1}$$

where:

k is the bearing resistance factor

$\sigma_{v,0}$ is the initial total vertical stress

p_{le}^* is the design net equivalent limit pressure (from the pressuremeter test)

and the other symbols defined in 1.6.

(3) Numerical values of the bearing resistance factor k are in the range of 0,8 to 3,0 depending on the type of soil, the embedment depth and the shape of the foundation.

(4) The design net equivalent limit pressure (p_{le}^*) is derived from the net limit pressure (p^*), which is defined for a pressuremeter test as the difference ($p_l - p_0$) between the limit pressure p_l and the at rest horizontal earth pressure p_0 at the level of the test; p_0 may be determined, from an estimate of the at rest earth pressure coefficient K_0 and from the values of the effective overburden pressure q' and the pore-water pressure u , as $p_0 = K_0 q' + u$.

Annex F (informative) Sample methods for settlement evaluation

F.1 Stress-strain method

(1) The total settlement of a foundation on cohesive or non-cohesive soil may be evaluated using the stress-strain calculation method as follows:

- computing the stress distribution in the ground due to the loading from the foundation; this may be derived on the basis of elasticity theory, generally assuming homogeneous isotropic soil and a linear distribution of bearing pressure;
- computing the strain in the ground from the stresses using stiffness moduli values or other stress-strain relationships determined from laboratory tests (preferably calibrated against field tests), or field tests;
- integrating the vertical strains to find the settlements; to use the stress-strain method a sufficient number of points within the ground beneath the foundation should be selected and the stresses and strains computed at these points.

F.2 Adjusted elasticity method

(1) The total settlement of a foundation on cohesive or non-cohesive soil may be evaluated using elasticity theory and an equation of the form:

$$\boxed{AC_1} s = p \times B \times f / E_m \boxed{AC_1} \quad (F.1)$$

where:

E_m is the design value of the modulus of elasticity

f is the settlement coefficient

p is the bearing pressure, linearly distributed on the base of the foundation

and the other symbols defined in 1.6

(2) The value of the settlement coefficient f depends on the shape and dimensions of the foundation area, the variation of stiffness with depth, the thickness of the compressible formation, Poisson's ratio, the distribution of the bearing pressure and the point for which the settlement is calculated.

(3) If no useful settlement results, measured on neighbouring similar structures in similar conditions are available, the design drained modulus E_m of the deforming stratum for drained conditions may be estimated from the results of laboratory or in-situ tests.

(4) The adjusted elasticity method should only be used if the stresses in the ground are such that no significant yielding occurs and if the stress-strain behaviour of the ground may be considered to be linear. Great caution is required when using the adjusted elasticity method in the case of non-homogeneous ground.

F.3 Settlements without drainage

(1) The short-term components of settlement of a foundation, which occur without drainage, may be evaluated using either the stress-strain method or the adjusted elasticity method. The values adopted for the stiffness parameters (such as E_m and Poisson's ratio) should in this case represent the undrained behaviour.

F.4 Settlements caused by consolidation

(1) To calculate the settlement caused by consolidation, a confined one-dimensional deformation of the soil may be assumed and the consolidation test curve is then used. Addition of settlements in the undrained and consolidation state often leads to an overestimate of the total settlement, and empirical corrections may be applied.

F.5 Time-settlement behaviour

(1) With cohesive soils the rate of consolidation settlement before the end of the primary consolidation may be estimated approximately using consolidation parameters obtained from a compression test. However, the rate of consolidation settlement should preferably be obtained using permeability values obtained from in-situ tests.

Annex G
(informative)

**A sample method for deriving presumed bearing resistance
for spread foundations on rock**

(1) For weak and broken rocks with tight joints, including chalk with porosity less than 35 %, the presumed bearing resistance may be derived from figure G.1. This is based on the grouping given in Table G.1 with the assumption that the structure can tolerate settlements equal to 0,5 % of the foundation width. Values of presumed bearing resistance for other settlements may be derived by direct proportion. For weak and broken rocks with open or infilled joints, reduced values of presumed bearing pressure should be used.

Table G.1 — Grouping of weak and broken rocks

Group	Type of rock
1	Pure limestones and dolomites Carbonate sandstones of low porosity
2	Igneous Oolitic and marly limestones Well cemented sandstones Indurated carbonate mudstones Metamorphic rocks, including slates and schist (flat cleavage/foliation)
3	Very marly limestones Poorly cemented sandstones Slates and schists (steep cleavage/foliation)
4	Uncemented mudstones and shales

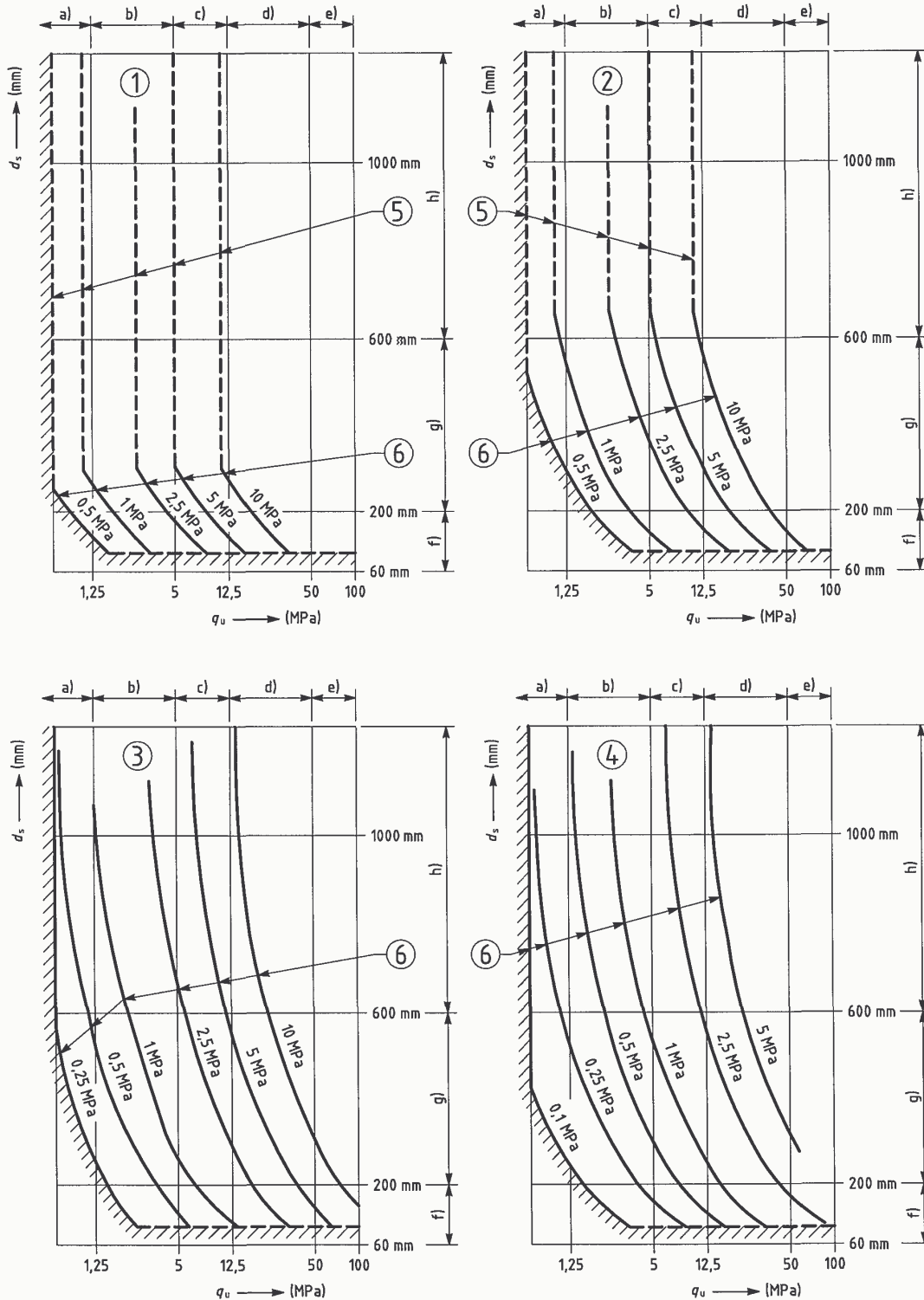

Abscissa: q_u (MPa): uniaxial compressive strength Ordinate: d_s (mm) discontinuity spacing
1 Group 1 rocks, 2 Group 2 rocks, 3 Group 3 rocks, 4 Group 4 rocks,

5 Allowable bearing pressure not to exceed uniaxial compressive strength of rock if joints are tight or 50 % of this value if joints are open,

6 Allowable bearing pressures: a) very weak rock, b) weak rock c) moderately weak rock
d) moderately strong rock, e) strong rock

Spacings: f) closely spaced discontinuities g) medium spaced discontinuities h) widely spaced discontinuities

For types of rock in each of four groups, see Table G.1. Presumed bearing resistance in hatched areas to be assessed after inspection and/or making tests on rock. (from BS 8004)

Figure G.1 — Presumed bearing resistance for square pad foundations bearing on rock (for settlements not exceeding 0,5 % of foundation width).

Annex H
(informative)
Limiting values of structural deformation and foundation movement

(1) The components of foundation movement, which should be considered include settlement, relative (or differential) settlement, rotation, tilt, relative deflection, relative rotation, horizontal displacement and vibration amplitude. Definitions of some terms for foundation movement and deformation are given in figure H.1.

(2) The maximum acceptable relative rotations for open framed structures, infilled frames and load bearing or continuous brick walls are unlikely to be the same but are likely to range from about 1/2000 to about 1/300, to prevent the occurrence of a serviceability limit state in the structure. A maximum relative rotation of 1/500 is acceptable for many structures. The relative rotation likely to cause an ultimate limit state is about 1/150.

(3) The ratios given in (2) apply to a sagging mode, as illustrated in figure H.1. For a hogging mode (edge settling more than part between), the value should be halved.

(4) For normal structures with isolated foundations, total settlements up to 50 mm are often acceptable. Larger settlements may be acceptable provided the relative rotations remain within acceptable limits and provided the total settlements do not cause problems with the services entering the structure, or cause tilting etc.

(5) These guidelines concerning limiting settlements apply to normal, routine structures. They should not be applied to buildings or structures, which are out of the ordinary or for which the loading intensity is markedly non-uniform.

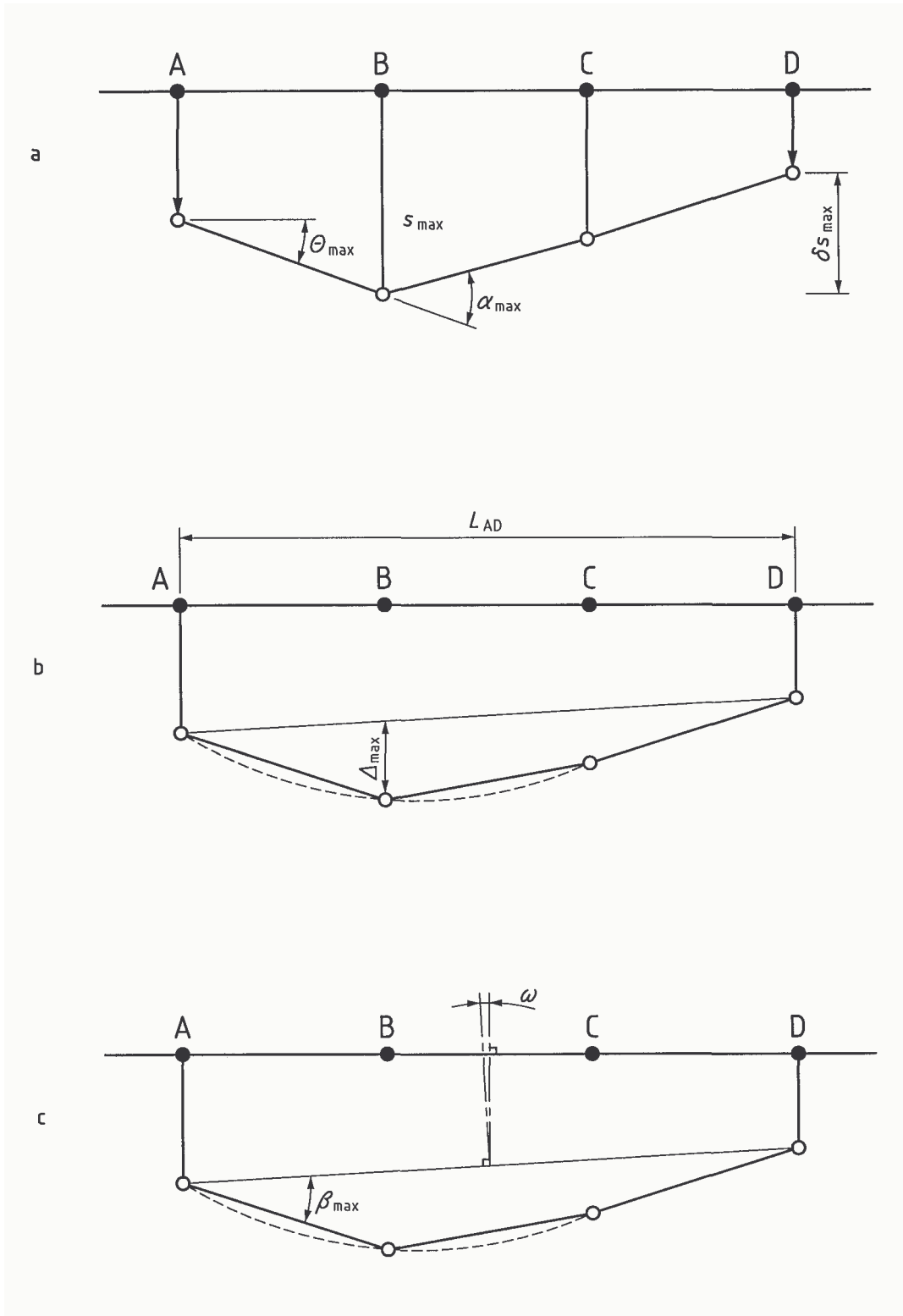

- a) definitions of settlement s , differential settlement δs , rotation θ and angular strain α
- b) definitions of relative deflection Δ and deflection ratio Δ/L
- c) definitions of tilt ω and relative rotation (angular distortion) β

Figure H.1 — Definitions of foundation movement

Annex J (informative) **Checklist for construction supervision and performance monitoring**

J.1 General

(1) The list that follows contains the more important items that should be considered when supervising construction or monitoring the performance of the completed structure. The importance of the items will vary from project to project. The list is not exhaustive. Items that refer to specific aspects of geotechnical engineering or to specific types of works have been reported in the Sections of this standard.

J.2 Construction supervision

J.2.1 General items to be checked

(1) Verification of ground conditions and of the location and general lay-out of the structure.

(2) Ground-water flow and pore-water pressure regime; effects of dewatering operations on ground-water table; effectiveness of measures taken to control seepage inflow; internal erosion processes and piping; chemical composition of ground-water; corrosion potential.

(3) Movements, yielding, stability of excavation walls and base; temporary support systems; effects on nearby buildings and utilities; measurement of soil pressures on retaining structures; measurement of pore-water pressure variations resulting from excavation or loading.

(4) Safety of workmen with due consideration of geotechnical limit states.

J.2.2 Water flow and pore-water pressures

(1) Adequacy of systems to ensure control of pore-water pressures in all aquifers where excess pressure could affect stability of slopes or base of excavation, including artesian pressures in an aquifer beneath the excavation; disposal of water from dewatering systems; depression of ground-water table throughout entire excavation to prevent boiling or quick conditions, piping and disturbance of formation by construction equipment; diversion and removal of rainfall or other surface water.

(2) Efficient and effective operation of dewatering systems throughout the entire construction period, considering encrusting of well screens, silting of wells or sumps; wear in pumps; clogging of pumps.

(3) Control of dewatering to avoid disturbance of adjoining structures or areas; observations of piezometric levels; effectiveness, operation and maintenance of water recharge systems, if installed.

(4) Settlement of adjoining structures or areas.

(5) Effectiveness of sub-horizontal borehole drains.

J.3 Performance monitoring

(1) Settlement at established time intervals of buildings and other structures including those due to effects of vibrations on metastable soils.

- (2) Lateral displacement and distortions, especially those related to fills and stockpiles; soil supported structures, such as buildings or large tanks; deep trenches.
- (3) Piezometric levels under buildings or in adjoining areas, especially if deep drainage or permanent dewatering systems are installed or if deep basements are constructed.
- (4) Deflection or displacement of retaining structures considering: normal backfill loadings; effects of stockpiles; fills or other surface loadings; water pressures.
- (5) Flow measurements from drains.
- (6) Special problems:
- High temperature structures such as boilers, hot ducts: desiccation of clay or silt soils; monitoring of temperatures; movements;
 - Low temperature structures, such as cryogenic installations or refrigerated areas: monitoring of temperature; ground freezing; frost heave; effects of subsequent thawing.
- (7) Water tightness.
- (8) Vibration measurements.

This page deliberately set blank

BSI - British Standards Institution

BSI is the independent national body responsible for preparing British Standards. It presents the UK view on standards in Europe and at the international level. It is incorporated by Royal Charter.

Revisions

British Standards are updated by amendment or revision. Users of British Standards should make sure that they possess the latest amendments or editions.

It is the constant aim of BSI to improve the quality of our products and services. We would be grateful if anyone finding an inaccuracy or ambiguity while using this British Standard would inform the Secretary of the technical committee responsible, the identity of which can be found on the inside front cover. Tel: +44 (0)20 8996 9000. Fax: +44 (0)20 8996 7400.

BSI offers members an individual updating service called PLUS which ensures that subscribers automatically receive the latest editions of standards.

Buying standards

Orders for all BSI, international and foreign standards publications should be addressed to Customer Services. Tel: +44 (0)20 8996 9001. Fax: +44 (0)20 8996 7001 Email: orders@bsigroup.com You may also buy directly using a debit/credit card from the BSI Shop on the Website <http://www.bsigroup.com/shop>

In response to orders for international standards, it is BSI policy to supply the BSI implementation of those that have been published as British Standards, unless otherwise requested.

Information on standards

BSI provides a wide range of information on national, European and international standards through its Library and its Technical Help to Exporters Service. Various BSI electronic information services are also available which give details on all its products and services. Contact Information Centre. Tel: +44 (0)20 8996 7111 Fax: +44 (0)20 8996 7048 Email: info@bsigroup.com

Subscribing members of BSI are kept up to date with standards developments and receive substantial discounts on the purchase price of standards. For details of these and other benefits contact Membership Administration. Tel: +44 (0)20 8996 7002 Fax: +44 (0)20 8996 7001 Email: membership@bsigroup.com

Information regarding online access to British Standards via British Standards Online can be found at <http://www.bsigroup.com/BSOL>

Further information about BSI is available on the BSI website at <http://www.bsigroup.com>

Copyright

Copyright subsists in all BSI publications. BSI also holds the copyright, in the UK, of the publications of the international standardization bodies. Except as permitted under the Copyright, Designs and Patents Act 1988 no extract may be reproduced, stored in a retrieval system or transmitted in any form or by any means – electronic, photocopying, recording or otherwise – without prior written permission from BSI.

This does not preclude the free use, in the course of implementing the standard, of necessary details such as symbols, and size, type or grade designations. If these details are to be used for any other purpose than implementation then the prior written permission of BSI must be obtained.

Details and advice can be obtained from the Copyright and Licensing Manager. Tel: +44 (0)20 8996 7070 Email: copyright@bsigroup.com