

# **Eurocode 1 — Actions on structures —**

## **Part 3: Actions induced by cranes and machinery**

The European Standard EN 1991-3:2006 has the status of a  
British Standard

ICS 91.010.30

## National foreword

This British Standard was published by BSI. It is the UK implementation of EN 1991-3:2006.

The structural Eurocodes are divided into packages by grouping Eurocodes for each of the main materials, concrete, steel, composite concrete and steel, timber, masonry and aluminium, this is to enable a common date of withdrawal (DOW) for all the relevant parts that are needed for a particular design. The conflicting national standards will be withdrawn at the end of the coexistence period, after all the EN Eurocodes of a package are available.

Following publication of the EN, there is a period allowed for national calibration during which the national annex is issued, followed by a further coexistence period of a maximum 3 years. During the coexistence period Member States will be encouraged to adapt their national provisions to withdraw conflicting national rules before the end of the coexistent period in March 2010.

At the end of this coexistence period, the national standard(s) will be withdrawn.

In the UK, the following national standards are superseded by the Eurocode 1 series. These standards will be withdrawn on a date to be announced.

Eurocode	Superseded British Standards
EN 1991-1-1	BS 6399-1:1996
EN 1991-1-2	none
EN 1991-1-3	BS 6399-3:1988
EN 1991-1-4	BS 6933-2:1997, BS 5400-2:1978*
EN 1991-1-5	BS 5400-2:1978*
EN 1991-1-6	none
EN 1991-1-7	none
EN 1991-2	BS 5400-1:1988, BS 5400-2:1978*
EN 1991-3	none
EN 1991-4	none

\* *N.B. BS 5400-2:1978 will not be fully superseded until publication of Annex A.2 to BS EN 1990:2002.*

The UK participation in its preparation was entrusted by Technical Committee B/525, Building and civil engineering structures, to Subcommittee B/525/1, Actions (loadings) on structures.

A list of organizations represented on B/525/1 can be obtained on request to its secretary.

Where a normative part of this EN allows for a choice to be made at the national level, the range and possible choice will be given in the normative text, and a note will qualify it as a Nationally Determined Parameter (NDP). NDPs can be a specific value for a factor, a specific level or class, a particular method or a particular application rule if several are proposed in the EN.

This British Standard was published under the authority of the Standards Policy and Strategy Committee on 29 September 2006

### Amendments issued since publication

Amd. No.	Date	Comments

© BSI 2006

ISBN 0 580 48268 5

To enable EN 1991-3 to be used in the UK, the NDPs will be published in a National Annex, which will be made available by BSI in due course, after public consultation has taken place.

This publication does not purport to include all the necessary provisions of a contract. Users are responsible for its correct application.

**Compliance with a British Standard cannot confer immunity from legal obligations.**

#### **Summary of pages**

This document comprises a front cover, an inside front cover, page i, a blank page, the EN title page, pages 2 to 46, an inside back cover and a back cover.

The BSI copyright notice displayed in this document indicates when the document was last issued.



EUROPEAN STANDARD

**EN 1991-3**

NORME EUROPÉENNE

EUROPÄISCHE NORM

July 2006

ICS 91.010.30

Supersedes ENV 1991-5:1998

English Version

## Eurocode 1 - Actions on structures - Part 3: Actions induced by cranes and machinery

Eurocode 1 - Actions sur les structures - Partie 3: Actions induites par les appareils de levage et les machines

Eurocode 1 - Einwirkungen auf Tragwerke - Teil 3: Einwirkungen infolge von Kranen und Maschinen

This European Standard was approved by CEN on 9 January 2006.

CEN members are bound to comply with the CEN/CENELEC Internal Regulations which stipulate the conditions for giving this European Standard the status of a national standard without any alteration. Up-to-date lists and bibliographical references concerning such national standards may be obtained on application to the Central Secretariat or to any CEN member.

This European Standard exists in three official versions (English, French, German). A version in any other language made by translation under the responsibility of a CEN member into its own language and notified to the Central Secretariat has the same status as the official versions.

CEN members are the national standards bodies of Austria, Belgium, Cyprus, Czech Republic, Denmark, Estonia, Finland, France, Germany, Greece, Hungary, Iceland, Ireland, Italy, Latvia, Lithuania, Luxembourg, Malta, Netherlands, Norway, Poland, Portugal, Romania, Slovakia, Slovenia, Spain, Sweden, Switzerland and United Kingdom.



EUROPEAN COMMITTEE FOR STANDARDIZATION  
COMITÉ EUROPÉEN DE NORMALISATION  
EUROPÄISCHES KOMITEE FÜR NORMUNG

Management Centre: rue de Stassart, 36 B-1050 Brussels

<b>CONTENTS</b>	<b>Page</b>
<b>FOREWORD</b> .....	<b>4</b>
BACKGROUND OF THE EUROCODE PROGRAMME.....	4
STATUS AND FIELD OF APPLICATION OF EUROCODES.....	5
NATIONAL STANDARDS IMPLEMENTING EUROCODES.....	6
LINKS BETWEEN EUROCODES AND HARMONISED TECHNICAL SPECIFICATIONS (ENs AND ETAs) FOR PRODUCTS.....	6
ADDITIONAL INFORMATION SPECIFIC FOR EN 1991-3.....	6
NATIONAL ANNEX FOR EN 1991-3.....	7
<b>SECTION 1 GENERAL</b> .....	<b>8</b>
1.1 SCOPE.....	8
1.2 NORMATIVE REFERENCES.....	8
1.3 DISTINCTION BETWEEN PRINCIPLES AND APPLICATION RULES.....	8
1.4 TERMS AND DEFINITIONS.....	9
1.4.1 Terms and definitions specifically for hoists and cranes on runway beams.....	9
1.4.2 Terms and definitions specifically for actions induced by machines.....	11
1.5 SYMBOLS.....	12
<b>SECTION 2 ACTIONS INDUCED BY HOISTS AND CRANES ON RUNWAY BEAMS</b> <b>14</b>	
2.1 FIELD OF APPLICATION.....	14
2.2 CLASSIFICATIONS OF ACTIONS.....	14
2.2.1 General.....	14
2.2.2 Variable actions.....	14
2.2.3 Accidental actions.....	15
2.3 DESIGN SITUATIONS.....	16
2.4 REPRESENTATION OF CRANE ACTIONS.....	17
2.5 LOAD ARRANGEMENTS.....	17
2.5.1 Monorail hoist blocks underslung from runway beams.....	17
2.5.1.1 Vertical loads.....	17
2.5.1.2 Horizontal forces.....	17
2.5.2 Overhead travelling cranes.....	17
2.5.2.1 Vertical loads.....	17
2.5.2.2 Horizontal forces.....	18
2.5.3 Multiple crane action.....	20
2.6 VERTICAL CRANE LOADS - CHARACTERISTIC VALUES.....	21
2.7 HORIZONTAL CRANE LOADS - CHARACTERISTIC VALUES.....	23
2.7.1 General.....	23
2.7.2 Longitudinal forces $H_{L,i}$ and transverse forces $H_{T,i}$ caused by acceleration and deceleration of the crane.....	23
2.7.3 Drive force $K$ .....	25
2.7.4 Horizontal forces $H_{S,i,j,k}$ and the guide force $S$ caused by skewing of the crane..	26
2.8 TEMPERATURE EFFECTS.....	30
2.9 LOADS ON ACCESS WALKWAYS, STAIRS, PLATFORMS AND GUARD RAILS.....	30
2.9.1 Vertical loads.....	30
2.9.2 Horizontal loads.....	30
2.10 TEST LOADS.....	30
2.11 ACCIDENTAL ACTIONS.....	31
2.11.1 Buffer forces $H_{B,1}$ related to crane movement.....	31
2.11.2 Buffer forces $H_{B,2}$ related to movements of the crab.....	32
2.11.3 Tilting forces.....	32

2.12	FATIGUE LOADS .....	32
2.12.1	<i>Single crane action</i> .....	32
2.12.2	<i>Stress range effects of multiple wheel or crane actions</i> .....	35
<b>SECTION 3 ACTIONS INDUCED BY MACHINERY .....</b>		<b>36</b>
3.1	FIELD OF APPLICATION.....	36
3.2	CLASSIFICATION OF ACTIONS.....	36
3.2.1	<i>General</i> .....	36
3.2.2	<i>Permanent actions</i> .....	36
3.2.3	<i>Variable actions</i> .....	37
3.2.4	<i>Accidental actions</i> .....	37
3.3	DESIGN SITUATIONS .....	37
3.4	REPRESENTATION OF ACTIONS.....	37
3.4.1	<i>Nature of the loads</i> .....	37
3.4.2	<i>Modelling of dynamic actions</i> .....	38
3.4.3	<i>Modelling of the machinery-structure interaction</i> .....	38
3.5	CHARACTERISTIC VALUES .....	39
3.6	SERVICEABILITY CRITERIA .....	41
<b>ANNEX A (NORMATIVE).....</b>		<b>43</b>
<b>BASIS OF DESIGN – SUPPLEMENTARY CLAUSES TO EN 1990 FOR RUNWAY BEAMS LOADED BY CRANES .....</b>		<b>43</b>
A.1	GENERAL .....	43
A.2	ULTIMATE LIMIT STATES.....	43
A.2.1	<i>Combinations of actions</i> .....	43
A.2.2	<i>Partial factors</i> .....	44
A.2.3	<i><math>\psi</math>-factors for crane loads</i> .....	44
A.3	SERVICEABILITY LIMIT STATES .....	45
A.3.1	<i>Combinations of actions</i> .....	45
A.3.2	<i>Partial factors</i> .....	45
A.3.3	<i><math>\psi</math>-factors for crane actions</i> .....	45
A.4	FATIGUE .....	45
<b>ANNEX B (INFORMATIVE) .....</b>		<b>46</b>
<b>GUIDANCE FOR CRANE CLASSIFICATION FOR FATIGUE .....</b>		<b>46</b>

## Foreword

This European Standard (EN 1991-3:2006) has been prepared by Technical Committee CEN/TC 250 “Structural Eurocodes”, the secretariat of which is held by BSI.

CEN/TC 250 is responsible for all Structural Eurocodes.

This European Standard supersedes ENV 1991-5:1998.

This European Standard shall be given the status of a national standard, either by publication of an identical text or by endorsement, at the latest by October 2006, and conflicting national standards shall be withdrawn at the latest by March 2010.

According to the CEN/CENELEC Internal Regulations, the national standards organizations of the following countries are bound to implement this European Standard: Austria, Belgium, Cyprus, Czech Republic, Denmark, Estonia, Finland, France, Germany, Greece, Hungary, Iceland, Ireland, Italy, Latvia, Lithuania, Luxembourg, Malta, Netherlands, Norway, Poland, Portugal, Romania, Slovakia, Slovenia, Spain, Sweden, Switzerland and the United Kingdom.

### Background of the Eurocode programme

In 1975, the Commission of the European Community decided on an action programme in the field of construction, based on article 95 of the Treaty. The objective of the programme was the elimination of technical obstacles to trade and the harmonisation of technical specifications.

Within this action programme, the Commission took the initiative to establish a set of harmonised technical rules for the design of construction works which, in a first stage, would serve as an alternative to the national rules in force in the Member States and, ultimately, would replace them.

For fifteen years, the Commission, with the help of a Steering Committee with Representatives of Member States, conducted the development of the Eurocodes programme, which led to the first generation of European codes in the 1980s.

In 1989, the Commission and the Member States of the EU and EFTA decided, on the basis of an agreement<sup>1</sup> between the Commission and CEN, to transfer the preparation and the publication of the Eurocodes to the CEN through a series of Mandates, in order to provide them with a future status of European Standard (EN). This links *de facto* the Eurocodes with the provisions of all the Council’s Directives and/or Commission’s Decisions dealing with European standards (e.g. the Council Directive 89/106/EEC on construction products - CPD - and Council Directives 93/37/EEC, 92/50/EEC and 89/440/EEC on public works and services and equivalent EFTA Directives initiated in pursuit of setting up the internal market).

---

<sup>1</sup> Agreement between the Commission of the European Communities and the European Committee for Standardisation (CEN) concerning the work on EUROCODES for the design of building and civil engineering works (BC/CEN/03/89).



The Structural Eurocode programme comprises the following standards generally consisting of a number of Parts:

EN 1990	Eurocode :	Basis of Structural Design
EN 1991	Eurocode 1:	Actions on structures
EN 1992	Eurocode 2:	Design of concrete structures
EN 1993	Eurocode 3:	Design of steel structures
EN 1994	Eurocode 4:	Design of composite steel and concrete structures
EN 1995	Eurocode 5:	Design of timber structures
EN 1996	Eurocode 6:	Design of masonry structures
EN 1997	Eurocode 7:	Geotechnical design
EN 1998	Eurocode 8:	Design of structures for earthquake resistance
EN 1999	Eurocode 9:	Design of aluminium structures

Eurocode standards recognise the responsibility of regulatory authorities in each Member State and have safeguarded their right to determine values related to regulatory safety matters at national level where these continue to vary from State to State.

### Status and field of application of Eurocodes

The Member States of the EU and EFTA recognise that Eurocodes serve as reference documents for the following purposes:

- as a means to prove compliance of building and civil engineering works with the essential requirements of Council Directive 89/106/EEC, particularly Essential Requirement N°1 – Mechanical resistance and stability – and Essential Requirement N°2 – Safety in case of fire ;
- as a basis for specifying contracts for construction works and related engineering services ;
- as a framework for drawing up harmonised technical specifications for construction products (ENs and ETAs)

The Eurocodes, as far as they concern the construction works themselves, have a direct relationship with the Interpretative Documents<sup>2</sup> referred to in Article 12 of the CPD, although they are of a different nature from harmonised product standards<sup>3</sup>. Therefore, technical aspects arising from the Eurocodes work need to be adequately considered by CEN Technical Committees and/or EOTA Working Groups working on product

<sup>2</sup> According to Art. 3.3 of the CPD, the essential requirements (ERs) shall be given concrete form in interpretative documents for the creation of the necessary links between the essential requirements and the mandates for harmonised ENs and ETAGs/ETAs.

<sup>3</sup> According to Art. 12 of the CPD the interpretative documents shall :

- a) give concrete form to the essential requirements by harmonising the terminology and the technical bases and indicating classes or levels for each requirement where necessary ;
- b) indicate methods of correlating these classes or levels of requirement with the technical specifications, e.g. methods of calculation and of proof, technical rules for project design, etc. ;
- c) serve as a reference for the establishment of harmonised standards and guidelines for European technical approvals.

The Eurocodes, *de facto*, play a similar role in the field of the ER 1 and a part of ER 2.

standards with a view to achieving full compatibility of these technical specifications with the Eurocodes.

The Eurocode standards provide common structural design rules for everyday use for the design of whole structures and component products of both a traditional and an innovative nature. Unusual forms of construction or design conditions are not specifically covered and additional expert consideration will be required by the designer in such cases.

### **National Standards implementing Eurocodes**

The National Standards implementing Eurocodes will comprise the full text of the Eurocode (including any annexes), as published by CEN, which may be preceded by a National title page and National foreword, and may be followed by a National annex.

The National annex may only contain information on those parameters which are left open in the Eurocode for national choice, known as Nationally Determined Parameters, to be used for the design of buildings and civil engineering works to be constructed in the country concerned, i.e. :

- values and/or classes where alternatives are given in the Eurocode,
- values to be used where a symbol only is given in the Eurocode,
- country specific data (geographical, climatic, etc.), e.g. snow map,
- the procedure to be used where alternative procedures are given in the Eurocode.

It may also contain:

- decisions on the application of informative annexes,
- references to non-contradictory complementary information to assist the user to apply the Eurocode.

### **Links between Eurocodes and harmonised technical specifications (ENs and ETAs) for products**

There is a need for consistency between the harmonised technical specifications for construction products and the technical rules for works<sup>4</sup>. Furthermore, all the information accompanying the CE Marking of the construction products which refer to Eurocodes should clearly mention which Nationally Determined Parameters have been taken into account.

### **Additional information specific for EN 1991-3**

EN 1991-3 gives design guidance and actions for the structural design of buildings and civil engineering works, including the following aspects:

- actions induced by cranes, and
- actions induced by machinery.

EN 1991-3 is intended for clients, designers, contractors and public authorities.

---

<sup>4</sup> see Art.3.3 and Art.12 of the CPD, as well as clauses 4.2, 4.3.1, 4.3.2 and 5.2 of ID 1.

EN 1991-3 is intended to be used with EN 1990, the other Parts of EN 1991 and EN 1992 to EN 1999 for the design of structures.

### National annex for EN 1991-3

This Standard gives alternative procedures, values and recommendations for classes with notes indicating where national choices have to be made. Therefore the National Standard implementing EN 1991-3 should have a National Annex containing all Nationally Determined Parameters to be used for the design of members to be constructed in the relevant country.

National choice is allowed in EN 1991-3 through the following paragraphs:

Paragraph	Item
2.1 (2)	Procedure when actions are given by the crane supplier
2.5.2.1 (2)	Eccentricity of wheel loads
2.5.3 (2)	Maximum number of cranes to be considered in the most unfavourable position
2.7.3 (3)	Value of friction factor
A2.2 (1)	Definition of $\gamma$ -values for cases STR and GEO
A2.2 (2)	Definition of $\gamma$ -values for case EQU
A2.3 (1)	Definition of $\psi$ -values

## Section 1 General

### 1.1 Scope

- (1) Part 3 of EN 1991 specifies imposed loads (models and representative values) associated with cranes on runway beams and stationary machines which include, when relevant, dynamic effects and braking, acceleration and accidental forces.
- (2) Section 1 defines common definitions and notations.
- (3) Section 2 specifies actions induced by cranes on runways.
- (4) Section 3 specifies actions induced by stationary machines.

### 1.2 Normative References

This European Standard incorporates by dated or undated reference provisions from other publications. These normative references are cited at the appropriate places in the text and the publications are listed hereafter. For dated references, subsequent amendments to, or revisions of, any of these publications apply to this European Standard only when incorporated in it by amendment or revision. For undated references the latest edition of the publication referred to applies (including amendments).

ISO 3898 Basis of design of structures - Notations. General symbols

ISO 2394 General principles on reliability for structures

ISO 8930 General principles on reliability for structures. List of equivalent terms

EN 1990 Eurocode: Basis of Structural Design

EN 13001-1 Cranes – General design – Part 1: General principles and requirements

EN 13001-2 Cranes – General design – Part 2: Load effects

EN 1993-1-9 Design of steel structures – Part 1-9: Fatigue

EN 1993-6 Design of steel structures – Part 6: Crane runway beams

### 1.3 Distinction between Principles and Application Rules

- (1) Depending on the character of the individual clauses, distinction is made in this Part of prEN 1991 between Principles and Application Rules.
- (2) The Principles comprise:
  - general statements and definitions for which there is no alternative, as well as
  - requirements and analytical models for which no alternative is permitted unless specifically stated.
- (3) The Principles are identified by the letter P following the paragraph number.

(4) The Application Rules are generally recognised rules which comply with the Principles and satisfy their requirements.

(5) It is permissible to use alternative design rules different from the Application Rules given in EN 1991-3 for works, provided that it is shown that the alternative rules accord with the relevant Principles and are at least equivalent with regard to the structural safety, serviceability and durability that would be expected when using the Eurocodes.

NOTE: If an alternative design rule is substituted for an Application Rule, the resulting design cannot be claimed to be wholly in accordance with EN 1991-3 although the design will remain in accordance with the Principles of EN 1991-3. When EN 1991-3 is used in respect of a property listed in an Annex Z of a product standard or an ETAG, the use of an alternative design rule may not be acceptable for CE marking.

(6) In this Part the Application Rules are identified by a number in brackets, e.g. as this clause.

## 1.4 Terms and definitions

For the purposes of this European Standard, the terms and definitions given in ISO 2394, ISO 3898, ISO 8930 and the following apply. Additionally for the purposes of this standard a basic list of terms and definitions is provided in EN 1990, 1.5.

### 1.4.1 Terms and definitions specifically for hoists and cranes on runway beams

#### 1.4.1.1

##### dynamic factor

factor that represents the ratio of the dynamic response to the static one

#### 1.4.1.2

##### self-weight $Q_c$ of the crane

self-weight of all fixed and movable elements including the mechanical and electrical equipment of a crane structure, however without the lifting attachment and a portion of the suspended hoist ropes or chains moved by the crane structure, see 1.4.1.3

#### 1.4.1.3

##### hoist load $Q_h$

load including the masses of the payload, the lifting attachment and a portion of the suspended hoist ropes or chains moved by the crane structure, see Figure 1.1

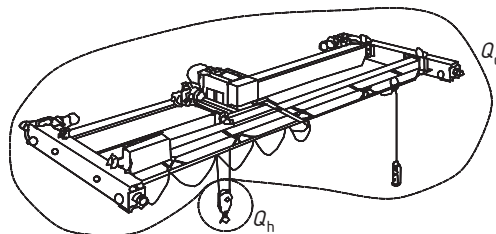

Figure 1.1 — Definition of the hoist load and the self-weight of a crane

**1.4.1.4**

**crab**

part of an overhead travelling crane that incorporates a hoist and is able to travel on rails on the top of the crane bridge

**1.4.1.5**

**crane bridge**

part of an overhead travelling crane that spans the crane runway beams and supports the crab or hoist block

**1.4.1.6**

**guidance means**

system used to keep a crane aligned on a runway, through horizontal reactions between the crane and the runway beams

NOTE The guidance means can consist of flanges on the crane wheels or a separate system of guide rollers operating on the side of the crane rails or the side of the runway beams

**1.4.1.7**

**hoist**

machine for lifting loads

**1.4.1.8**

**hoist block**

underslung trolley that incorporates a hoist and is able to travel on the bottom flange of a beam, either on a fixed runway (as shown in Figure 1.2) or under the bridge of an overhead travelling crane (as shown in Figures 1.3 and 1.4)

**1.4.1.9**

**monorail hoist block**

hoist block that is supported on a fixed runway, see Figure 1.2

**1.4.1.10**

**crane runway beam**

beam along which an overhead travelling crane can move

**1.4.1.11**

**overhead travelling crane**

a machine for lifting and moving loads, that moves on wheels along overhead crane runway beams. It incorporates one or more hoists mounted on crabs or underslung trolleys

**1.4.1.12**

**runway beam for hoist block**

crane runway beam provided to support a monorail hoist block that is able to travel on its bottom flange, see Figure 1.2

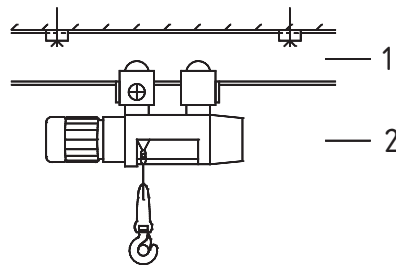
**Key**

- 1 Runway beam
- 2 Hoist block

**Figure 1.2 — Runway beam with hoist block**

#### 1.4.1.13 underslung crane

overhead travelling crane that is supported on the bottom flanges of the crane runway beams, see Figure 1.3

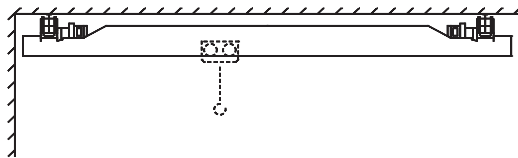
**Figure 1.3 — Underslung crane with hoist block**

#### 1.4.1.14 top-mounted crane

overhead travelling crane that is supported on the top of the crane runway beam

NOTE It usually travels on rails, but sometimes travels directly on the top of the beams, see Figure 1.4

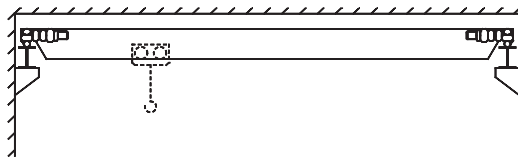
**Figure 1.4 — Top mounted crane with hoist block**

### 1.4.2 Terms and definitions specifically for actions induced by machines

#### 1.4.2.1 natural frequency

frequency of free vibration on a system

NOTE For a multiple degree-of-freedom system, the natural frequencies are the frequencies of the normal modes of vibrations

#### 1.4.2.2

##### **free vibration**

vibration of a system that occurs in the absence of forced vibration

#### 1.4.2.3

##### **forced vibration**

vibration of a system if the response is imposed by the excitation

#### 1.4.2.4

##### **damping**

dissipation of energy with time or distance

#### 1.4.2.5

##### **resonance**

resonance of a system in forced harmonic vibration exists when any change, however small, in the frequency of excitation causes a decrease in the response of the system

#### 1.4.2.6

##### **mode of vibration**

characteristic pattern assumed by a system undergoing vibration in which the motion of every particle is simple harmonic with the same frequency

NOTE Two or more modes may exist concurrently in a multiple degree of freedom system. A normal (natural) mode of vibration is a mode of vibration that is uncoupled from other modes of vibration of a system

### 1.5 Symbols

(1) For the purposes of this European standard, the following symbols apply.

NOTE: The notation used is based on ISO 3898: 1997.

(2) A basic list of symbols is provided in EN 1990 clause 1.6 and the additional notations below are specific to this part of EN 1991.

#### *Latin upper case letters*

$F_{\phi,k}$	characteristic value of a crane action
$F_k$	characteristic static component of a crane action
$F_S$	free force of the rotor
$F_w^*$	forces caused by in-service wind
$H_{B,1}$	buffer forces related to movements of the crane
$H_{B,2}$	buffer forces related to movements of the crab
$H_K$	horizontal load for guard rails
$H_L$	longitudinal forces caused by acceleration and deceleration of the crane
$H_S$	horizontal forces caused by skewing of the crane
$H_{T,1}, H_{T,2}$	transverse forces caused by acceleration and deceleration of the crane
$H_{T,3}$	transverse forces caused by acceleration and deceleration of the crab
$H_{TA}$	tilting force
$K$	drive force



$M_k(t)$	circuit moment
$Q_e$	fatigue load
$Q_c$	self-weight of the crane
$Q_h$	hoist load
$Q_T$	test load
$Q_r$	wheel load
$S$	guide force

*Latin lower case letters*

$b_r$	width of rail head
$e$	eccentricity of wheel load
$e_M$	eccentricity of the rotor mass
$h$	distance between the instantaneous slide pole and means of guidance
$k_Q$	load spectrum factor
$\ell$	span of the crane bridge
$m_c$	mass of the crane
$m_w$	number of single wheel drives
$m_r$	mass of rotor
$n$	number of wheel pairs
$n_r$	number of runway beams

*Greek lower case letters*

$\alpha$	skewing angle
$\zeta$	damping ratio
$\eta$	ratio of the hoist load that remains when the payload is removed, but is not included in the self-weight of the crane
$\lambda$	damage equivalent factor
$\lambda_s$	force factors
$\mu$	friction factor
$\xi_b$	buffer characteristic
$\varphi$	dynamic factor
$\varphi_1, \varphi_2, \varphi_3$	dynamic factor applied to actions induced by cranes
$\varphi_4, \varphi_5, \varphi_6, \varphi_7$	
$\varphi_{fat}$	damage equivalent dynamic impact factor
$\varphi_M$	dynamic factor applied to actions induced by machines
$\omega_e$	natural frequency of the structure
$\omega_r$	circular frequency of the rotor
$\omega_s$	frequency of the exiting force

## Section 2 Actions induced by hoists and cranes on runway beams

### 2.1 Field of application

- (1) This section specifies actions (models and representative values) induced by:
- underslung trolleys on runways, see 2.5.1 and 2.5.2;
  - overhead travelling cranes, see 2.5.3 and 2.5.4.
- (2) The methods prescribed in this section are compatible with the provisions in EN 13001-1 and EN 13001-2, to facilitate the exchange of data with crane suppliers.

NOTE: Where the crane supplier is known at the time of design of the crane runway, more accurate data may be applied for the individual project. The National Annex may give information on the procedure.

### 2.2 Classifications of actions

#### 2.2.1 General

- (1)P Actions induced by cranes shall be classified as variable and accidental actions which are represented by various models as described in 2.2.2 and 2.2.3.

#### 2.2.2 Variable actions

- (1) For normal service conditions variable crane actions result from variation in time and location. They include gravity loads including hoist loads, inertial forces caused by acceleration/deceleration and by skewing and other dynamic effects.

- (2) The variable crane actions should be separated into:
- variable vertical crane actions caused by the self-weight of the crane and the hoist load;
  - variable horizontal crane actions caused by acceleration or deceleration or by skewing or other dynamic effects.

- (3) The various representative values of variable crane actions are characteristic values composed of a static and a dynamic component.

- (4) Dynamic components induced by vibration due to inertial and damping forces are in general accounted by dynamic factors  $\varphi$  to be applied to the static action values.

$$F_{\varphi,k} = \varphi_i F_k \quad (2.1)$$

where:

- $F_{\varphi,k}$  is the characteristic value of a crane action;
- $\varphi_i$  is the dynamic factor, see Table 2.1;
- $F_k$  is the characteristic static component of a crane action.

- (5) The various dynamic factors and their application are listed in Table 2.1.

(6) The simultaneity of the crane load components may be taken into account by considering groups of loads as identified in Table 2.2. Each of these groups of loads should be considered as defining one characteristic crane action for the combination with non-crane loads.

NOTE: The grouping provides that only one horizontal crane action is considered at a time.

### 2.2.3 Accidental actions

(1) Cranes can generate accidental actions due to collision with buffers (buffer forces) or collision of lifting attachments with obstacles (tilting forces). These actions should be considered for the structural design where appropriate protection is not provided.

(2) Accidental actions described in 2.11 refer to common situations. They are represented by various load models defining design values (i.e. to be used with  $\gamma_A = 1,0$ ) in the form of equivalent static loads.

(3) The simultaneity of accidental crane load components may be taken into account by considering groups of loads as identified in Table 2.2. Each of these groups of loads defines one crane action for the combination of non-crane loads.

**Table 2.1 — Dynamic factors  $\varphi_i$**

Dynamic factors	Effects to be considered	To be applied to
$\varphi_1$	– excitation of the crane structure due to lifting the hoist load off the ground	self-weight of the crane
$\varphi_2$ or $\varphi_3$	–dynamic effects of transferring the hoist load from the ground to the crane  –dynamic effects of sudden release of the payload if for example grabs or magnets are used	hoist load
$\varphi_4$	–dynamic effects induced when the crane is travelling on rail tracks or runways	self-weight of the crane and hoist load
$\varphi_5$	–dynamic effects caused by drive forces	drive forces
$\varphi_6$	–dynamic effects of a test load moved by the drives in the way the crane is used	test load
$\varphi_7$	–dynamic elastic effects of impact on buffers	buffer loads

**Table 2.2 — Groups of loads and dynamic factors to be considered as one characteristic crane action**

		Symbol	Section	Groups of loads									
				Ultimate Limit State							Test load	Accidental	
				1	2	3	4	5	6	7	8	9	10
1	Self-weight of crane	$Q_c$	2.6	$\varphi_1$	$\varphi_1$	1	$\varphi_4$	$\varphi_4$	$\varphi_4$	1	$\varphi_1$	1	1
2	Hoist load	$Q_h$	2.6	$\varphi_2$	$\varphi_3$	-	$\varphi_4$	$\varphi_4$	$\varphi_4$	$\eta^{1)}$	-	1	1
3	Acceleration of crane bridge	$H_L, H_T$	2.7	$\varphi_5$	$\varphi_5$	$\varphi_5$	$\varphi_5$	-	-	-	$\varphi_5$	-	-
4	Skewing of crane bridge	$H_S$	2.7	-	-	-	-	1	-	-	-	-	-
5	Acceleration or braking of crab or hoist block	$H_{T3}$	2.7	-	-	-	-	-	1	-	-	-	-
6	In-service wind	$F_W^*$	Annex A	1	1	1	1	1	-	-	1	-	-
7	Test load	$Q_T$	2.10	-	-	-	-	-	-	-	$\varphi_6$	-	-
8	Buffer force	$H_B$	2.11	-	-	-	-	-	-	-	-	$\varphi_7$	-
9	Tilting force	$H_{TA}$	2.11	-	-	-	-	-	-	-	-	-	1

NOTE: For out of service wind, see Annex A.

<sup>1</sup>  $\eta$  is the proportion of the hoist load that remains when the payload is removed, but is not included in the self-weight of the crane.

### 2.3 Design situations

(1)P The relevant actions induced by cranes shall be determined for each design situation identified in accordance with EN 1990.

(2)P Selected design situations shall be considered and critical load cases identified. For each critical load case the design values of the effects of actions in combination shall be determined.

(3) Rules for multiple crane actions from several cranes are given in 2.5.3.

(4) Combination rules for crane actions with other actions are given in Annex A.

(5) For the fatigue verification, fatigue load models are given in 2.12.

(6) In case tests are performed with cranes on the supporting structures for the serviceability limit state verification, the test loading model of the crane is specified in 2.10.

## 2.4 Representation of crane actions

- (1) The actions to be considered should be those exerted on the crane runway beams by the wheels of the cranes and possibly by guide rollers or other guidance means.
- (2) Horizontal forces on crane supporting structures arising from horizontal movement of monorail hoist cranes and crane hoists should be determined from 2.5.1.2, 2.5.2.2 and 2.7.

## 2.5 Load arrangements

### 2.5.1 Monorail hoist blocks underslung from runway beams

#### 2.5.1.1 Vertical loads

- (1) For normal service conditions, the vertical load should be taken as composed of the self-weight of the hoist block, the hoist load and the dynamic factor, see Table 2.1 and Table 2.2.

#### 2.5.1.2 Horizontal forces

- (1) In the case of fixed runway beams for monorail underslung trolleys, in the absence of a more accurate value, the longitudinal horizontal forces should be taken as 5 % of the maximum vertical wheel load, neglecting the dynamic factor.
- (2) This also applies to horizontal loads in the case of swinging suspended runway beams.

### 2.5.2 Overhead travelling cranes

#### 2.5.2.1 Vertical loads

- (1) The relevant vertical wheel loads from a crane on a runway beam, should be determined by considering the load arrangements illustrated in Figure 2.1, using the characteristic values given in 2.6.

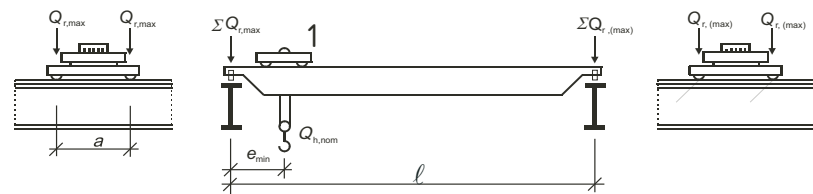

a) Load arrangement of the loaded crane to obtain the maximum loading on the runway beam

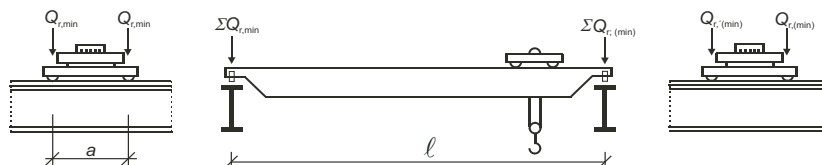

b) Load arrangement of the unloaded crane to obtain the minimum loading on the runway beam

where:

- $Q_{r,max}$  is the maximum load per wheel of the loaded crane  
 $Q_{r,(max)}$  is the accompanying load per wheel of the loaded crane  
 $\Sigma Q_{r,max}$  is the sum of the maximum loads  $Q_{r,max}$  per runway of the loaded crane  
 $\Sigma Q_{r,(max)}$  is the sum of the accompanying maximum loads  $Q_{r,(max)}$  per runway of the loaded crane  
 $Q_{r,min}$  is the minimum load per wheel of the unloaded crane  
 $Q_{r,(min)}$  is the accompanying load per wheel of the unloaded crane  
 $\Sigma Q_{r,min}$  is the sum of the minimum loads  $Q_{r,min}$  per runway of the unloaded crane  
 $\Sigma Q_{r,(min)}$  is the sum of the accompanying minimum loads  $Q_{r,(min)}$  per runway of the unloaded crane  
 $Q_{h,nom}$  is the nominal hoist load

### Key

- 1 Crab

**Figure 2.1 — Load arrangements to obtain the relevant vertical actions to the runway beams**

(2) The eccentricity of application  $e$  of a wheel load  $Q_r$  to a rail should be taken as a portion of the width of the rail head  $b_r$ , see Figure 2.2.

NOTE: The National Annex may give the value of  $e$ . The recommended value is  $e = 0,25 b_r$ .

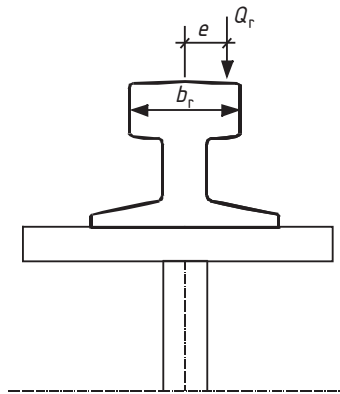

**Figure 2.2 — Eccentricity of application of wheel load**

#### 2.5.2.2 Horizontal forces

(1) The following types of horizontal forces from overhead travelling cranes should be taken into account:

- a) horizontal forces caused by acceleration or deceleration of the crane in relation to its movement along the runway beam, see 2.7.2;

- b) horizontal forces caused by acceleration or deceleration of the crab or underslung trolley in relation to its movement along the crane bridge, see 2.7.5;
- c) horizontal forces caused by skewing of the crane in relation to its movement along the runway beam, see 2.7.4;
- d) buffer forces related to crane movement, see 2.11.1;
- e) buffer forces related to movement of the crab or underslung trolley, see 2.11.2.

(2) Unless otherwise specified, only one of the five types of horizontal forces (a) to (e) listed in (1) should be included in the same group of simultaneous crane load components, see Table 2.2.

(3) For underslung cranes the horizontal forces at the wheel contact surface should be taken as at least 10 % of the maximum vertical wheel load neglecting the dynamic component unless a more accurate value is justified.

(4) Unless otherwise specified, the longitudinal horizontal wheel forces  $H_{L,i}$  and the transverse horizontal wheel forces  $H_{T,i}$  caused by acceleration and deceleration of masses of the crane or the crab etc., should be applied as given in Figure 2.3. The characteristic values of these forces are given in 2.7.2.

NOTE: These forces do not include the effects of oblique hoisting due to misalignment of load and crab because in general oblique hoisting is forbidden. Any effects of unavoidable small values of oblique hoisting are included in the inertial forces.

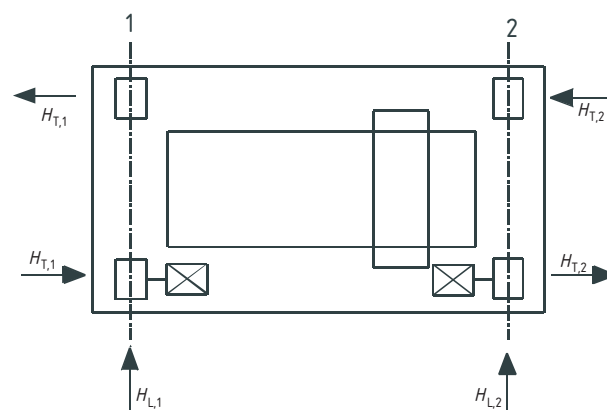

**Key**

- 1 Rail i = 1
- 2 Rail i = 2

**Figure 2.3 — Load arrangement of longitudinal and transverse horizontal wheel forces caused by acceleration and deceleration**

(5) The longitudinal and transverse horizontal wheel forces  $H_{S,i,j,k}$  and the guide force  $S$  caused by skewing can occur at the guidance means of cranes or trolleys while they are travelling or traversing in steady state motion, see Figure 2.4. These loads are induced by guidance reactions which force the wheel to deviate from their free-rolling natural travelling or traverse direction. The characteristic values are given in 2.7.4.

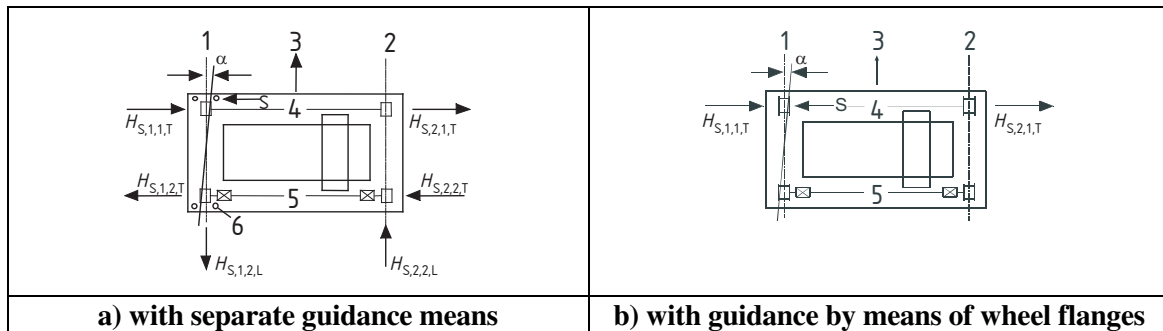

### Key

- 1 Rail  $i = 1$
- 2 Rail  $i = 2$
- 3 Direction of motion
- 4 Wheel pair  $j = 1$
- 5 Wheel pair  $j = 2$
- 6 Guide means

NOTE 1: The direction of the horizontal forces depends on the type of guidance means, the direction of motion and on the type of wheel drive.

NOTE 2: The forces  $H_{S,i,j,k}$  are defined in 2.7.4(1).

**Figure 2.4 — Load arrangement of longitudinal and transverse horizontal wheel forces caused by skewing**

### 2.5.3 Multiple crane action

(1) P Cranes that are required to operate together shall be treated as a single crane action.

(2) If several cranes are operating independently, the maximum number of cranes taken into account as acting simultaneously should be specified.

NOTE: The number of cranes to be considered in the most unfavourable position may be specified in the National Annex. The recommended number is given in Table 2.3.

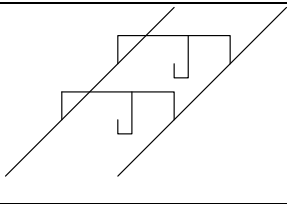
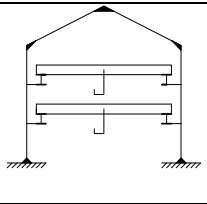
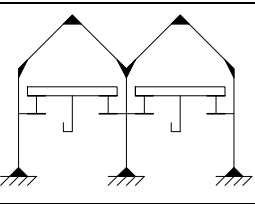

**Table 2.3 — Recommended maximum number of cranes to be considered in the most unfavourable position**

	Cranes to each runway	Cranes in each shop bay	Cranes in multi – bay buildings	
				
Vertical crane action	3	4	4	2
Horizontal crane action	2	2	2	2

## 2.6 Vertical crane loads - characteristic values

(1) The characteristic values of the vertical loads from cranes on crane supporting structures should be determined as indicated in Table 2.2.

(2)P For the self-weight of the crane and the hoist load, the nominal values specified by the crane supplier shall be taken as characteristic values of the vertical loads.

**Table 2.4 — Dynamic factors  $\varphi_i$  for vertical loads**

Values of dynamic factors	
$\varphi_1$	$0,9 < \varphi_1 < 1,1$ The two values 1,1 and 0,9 reflect the upper and lower values of the vibrational pulses.
$\varphi_2$	$\varphi_2 = \varphi_{2,\min} + \beta_2 v_h$ $v_h$ - steady hoisting speed in m/s $\varphi_{2,\min}$ and $\beta_2$ see Table 2.5
$\varphi_3$	$\varphi_3 = 1 - \frac{\Delta m}{m} (1 + \beta_3)$ where $\Delta m$ released or dropped part of the hoisting mass $m$ total hoisting mass $\beta_3 = 0,5$ for cranes equipped with grabs or similar slow-release devices $\beta_3 = 1,0$ For cranes equipped with magnets or similar rapid-release devices
$\varphi_4$	$\varphi_4 = 1,0$ provided that the tolerances for rail tracks as specified in EN 1993-6 are observed.
NOTE: If the tolerances for rail tracks as specified in EN 1993-6 are not observed, the dynamic factor $\varphi_4$ can be determined with the model provided by EN 13001-2.	

(3) If the dynamic factors  $\varphi_1$ ,  $\varphi_2$ ,  $\varphi_3$  and  $\varphi_4$  as specified in Table 2.1 are not included in the specifications of the crane supplier the indications in Table 2.4 may be used.

(4) For in-service wind reference should be made to Annex A.

**Table 2.5 — Values of  $\beta_2$  and  $\varphi_{2,\min}$** 

Hoisting class of appliance	$\beta_2$	$\varphi_{2,\min}$
HC1	0,17	1,05
HC2	0,34	1,10
HC3	0,51	1,15
HC4	0,68	1,20
NOTE: Cranes are assigned to Hoisting Classes HC1 to HC4 to allow for the dynamic effects of transferring the load from the ground to the crane. The selection depends on the particular type of crane, see recommendation in annex B.		

## 2.7 Horizontal crane loads - characteristic values

### 2.7.1 General

(1)P For the acceleration and the skewing effects, the nominal values specified by the crane supplier shall be taken as characteristic values of the horizontal loads.

(2) The characteristic values of the horizontal loads may be specified by the crane supplier or be determined using 2.7.2 to 2.7.5.

### 2.7.2 Longitudinal forces $H_{L,i}$ and transverse forces $H_{T,i}$ caused by acceleration and deceleration of the crane

(1) The longitudinal forces  $H_{L,i}$  caused by acceleration and deceleration of crane structures result from the drive force at the contact surface between the rail and the driven wheel, see Figure 2.5.

(2) The longitudinal forces  $H_{L,i}$  applied to a runway beam may be calculated as follows:

$$H_{L,i} = \varphi_5 K \frac{1}{n_r} \quad (2.2)$$

where:

$n_r$  is the number of runway beams;

$K$  is the drive force according to 2.7.3;

$\varphi_5$  is the dynamic factor, see Table 2.6;

$i$  is the integer to identify the runway beam ( $i = 1, 2$ ).

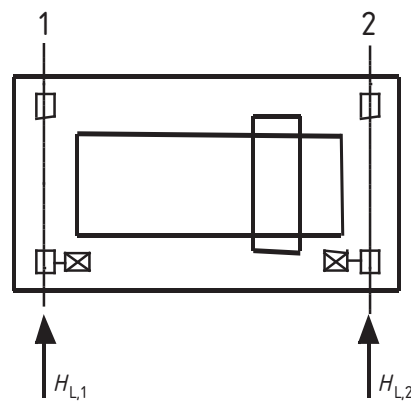

#### Key

- 1 Rail  $i = 1$
- 2 Rail  $i = 2$

**Figure 2.5: Longitudinal horizontal forces  $H_{L,i}$**

(3) The moment  $M$  resulting from the drive force which should be applied at the centre of mass is equilibrated by transverse horizontal forces  $H_{T,1}$  and  $H_{T,2}$ , see Figure 2.6. The horizontal forces may be calculated as follows:

$$H_{T,1} = \varphi_5 \xi_2 \frac{M}{a} \quad (2.3)$$

$$H_{T,2} = \varphi_5 \xi_1 \frac{M}{a} \quad (2.4)$$

where:

$$\xi_1 = \frac{\sum Q_{r,\max}}{\sum Q_r}$$

$$\xi_2 = 1 - \xi_1;$$

$$\sum Q_r = \sum Q_{r,\max} + \sum Q_{r,(max)};$$

$\sum Q_{r,\max}$  see Figure 2.1;

$\sum Q_{r,(max)}$  see Figure 2.1;

$a$  is the spacing of the guide rollers or the flanged wheels ;

$$M = K l_s ;$$

$$l_s = (\xi_1 - 0,5) l ;$$

$l$  is the span of the crane bridge;

$\varphi_5$  is the dynamic factor, see Table 2.6;

$K$  is the drive force, see 2.7.3 and Figure 2.7.

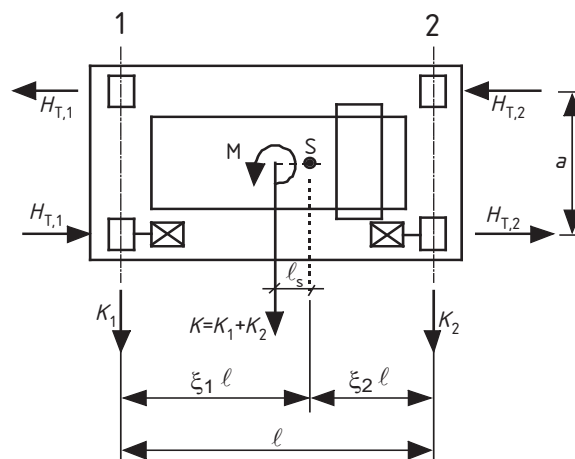

### Key

- 1 Rail i = 1
- 2 Rail i = 2

**Figure 2.6 — Definition of the transverse forces  $H_{T,i}$**

(4) For curved runway beams the resulting centrifugal force should be multiplied by the dynamic factor  $\varphi_5$ .

(5) If the dynamic factor  $\varphi_5$  is not included in the specification documents of the crane supplier, values given in Table 2.6 may be used.

**Table 2.6 — Dynamic factor  $\varphi_5$** 

Values of the dynamic factor $\varphi_5$	Specific use
$\varphi_5 = 1,0$	for centrifugal forces
$1,0 \leq \varphi_5 \leq 1,5$	for systems where forces change smoothly
$1,5 \leq \varphi_5 \leq 2,0$	for cases where sudden changes can occur
$\varphi_5 = 3,0$	for drives with considerable backlash

**2.7.3 Drive force  $K$** 

(1) The drive force  $K$  on a driven wheel should be taken such that wheel spin is prevented.

(2) The drive force  $K$  should be obtained from the crane supplier.

(3) Where no wheel controlled system is applied, the drive force  $K$  may be calculated as follows:

$$K = K_1 + K_2 = \mu \sum Q_{r,\min}^* \quad (2.5)$$

where:

$\mu$  is the friction factor;

- for a single wheel drive:  $\sum Q_{r,\min}^* = m_w Q_{r,\min}$ , where  $m_w$  is the number of single wheel drives;
- for a central wheel drive:  $\sum Q_{r,\min}^* = Q_{r,\min} + Q_{r,(min)}$ ;

NOTE 1: Modern cranes do not normally have a central wheel drive.

NOTE 2: The value of the friction factor may be given in the National Annex. The recommended values are:

- $\mu = 0,2$  for steel - steel;
- $\mu = 0,5$  for steel - rubber.

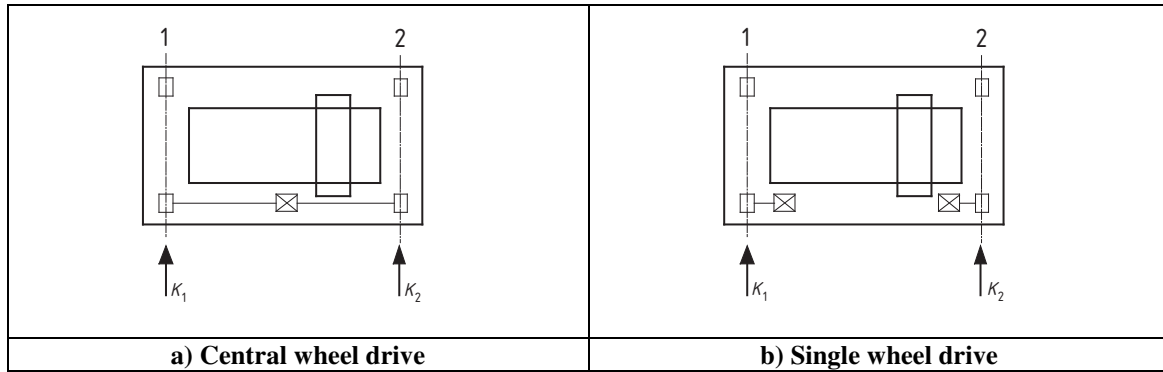
**Key**

- 1 Rail  $i = 1$   
 2 Rail  $i = 2$

**Figure 2.7 — Definition of the drive force  $K$** **2.7.4 Horizontal forces  $H_{S,i,j,k}$  and the guide force  $S$  caused by skewing of the crane**

(1) The guide force  $S$  and the transverse forces  $H_{S,i,j,k}$  caused by skewing may be obtained from:

$$S = f \lambda_{S,j} \sum Q_r \quad (2.6)$$

$$H_{S,1,j,L} = f \lambda_{S,1,j,L} \sum Q_r \quad (\text{index } j \text{ indicates the driven wheel pair}) \quad (2.7)$$

$$H_{S,2,j,L} = f \lambda_{S,2,j,L} \sum Q_r \quad (\text{index } j \text{ indicates the driven wheel pair}) \quad (2.8)$$

$$H_{S,1,j,T} = f \lambda_{S,1,j,T} \sum Q_r \quad (2.9)$$

$$H_{S,2,j,T} = f \lambda_{S,2,j,T} \sum Q_r \quad (2.10)$$

where:

$f$  is the “non-positive factor”, see (2);

$\lambda_{S,i,j,k}$  is the force factor, see (4);

$i$  is the rail  $i$ ;

$j$  is the wheel pair  $j$ ;

$k$  is the direction of the force (L = longitudinal, T = transverse).

(2) The “non-positive” factor may be determined from:

$$f = 0,3 (1 - \exp(-250 \alpha)) \leq 0,3 \quad (2.11)$$

where:

$\alpha$  is the skewing angle, see (3).

(3) The skewing angle  $\alpha$ , see Figure 2.8, which should be equal to or less than 0,015 rad, should be chosen taking into account the space between the guidance means and the rail as well as reasonable dimensional variation and wear of the appliance wheels and the rails. It may be determined as follows:

$$\alpha = \alpha_F + \alpha_V + \alpha_0 \leq 0,015 \text{ rad} \quad (2.12)$$

where:

$\alpha_F$ ,  $\alpha_V$  and  $\alpha_0$  are as defined in Table 2.7.

**Table 2.7 — Definition of  $\alpha_F$ ,  $\alpha_V$  and  $\alpha_0$**

Angles $\alpha_i$	Minimum values of $\alpha_i$
$\alpha_F = \frac{0,75x}{a_{\text{ext}}}$	$0,75x \geq 5 \text{ mm}$ for guide rollers
	$0,75x \geq 10 \text{ mm}$ for wheel flanges
$\alpha_V = \frac{y}{a_{\text{ext}}}$	$y \geq 0,03b \text{ mm}$ for guide rollers
	$y \geq 0,10b \text{ mm}$ for wheel flanges
$\alpha_0$	$\alpha_0 = 0,001$
Where: $a_{\text{ext}}$ is the spacing of the outer guidance means or flanged wheels on the guiding rail; $b$ is the width of the rail head; $x$ is the track clearance between the rail and the guidance means (lateral slip); $y$ is the wear of the rail and the guidance means; $\alpha_0$ is the tolerance on wheel and rail directions.	

(4) The force factor  $\lambda_{S,i,j,k}$  depends on the combination of the wheel pairs and the distance  $h$  between the instantaneous centre of rotation and the relevant guidance means, i.e. the front ones in the direction, see Figure 2.8. The value of the distance  $h$  may be taken from Table 2.8. The force factor  $\lambda_{S,i,j,k}$  may be determined from the expressions given in Table 2.9.

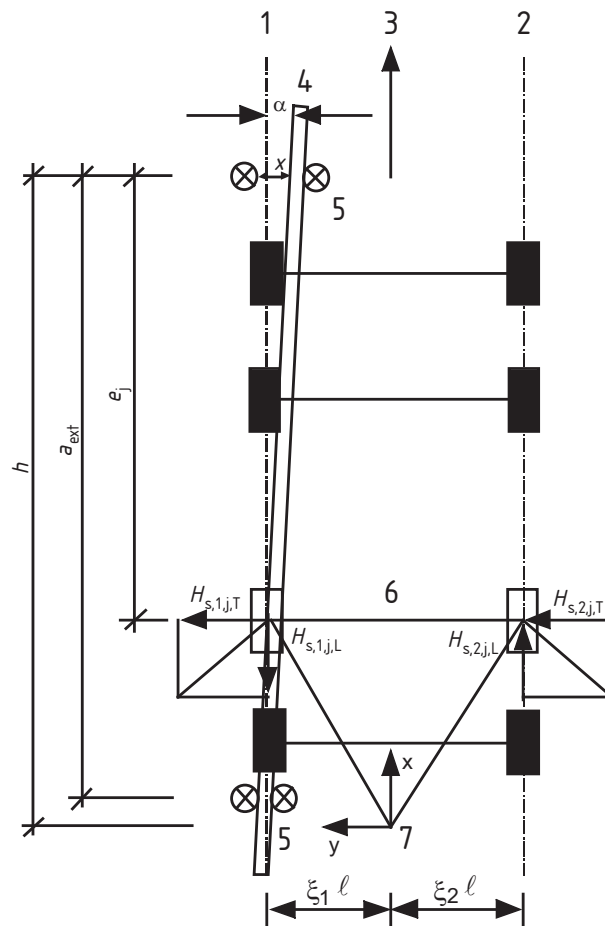

**Key**

- 1 Rail  $i = 1$
- 2 Rail  $i = 2$
- 3 Direction of motion
- 4 Direction of rail
- 5 Guidance means
- 6 Wheel pair  $j$
- 7 Instantaneous centre of rotation

**Figure 2.8 — Definition of angle  $\alpha$  and the distance  $h$**

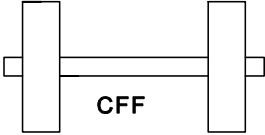
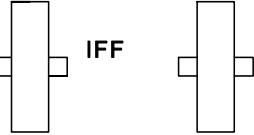
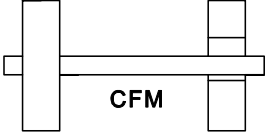
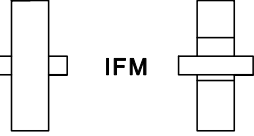

**Table 2.8 — Determination of the distance  $h$** 

Fixing of wheels according to lateral movements	Combination of wheel pairs		$h$
	coupled (c)	independent (i)	
Fixed/Fixed FF			$\frac{m \xi_1 \xi_2  ^2 + \sum e_j^2}{\sum e_j}$
Fixed/Movable FM			$\frac{m \xi_1  ^2 + \sum e_j^2}{\sum e_j}$
Where:			
$h$ is the distance between the instantaneous centre of rotation and the relevant guidance means;			
$m$ is the number of pairs of coupled wheels ( $m = 0$ for independent wheel pairs);			
$\xi_1  $ is the distance of the instantaneous centre of rotation from rail 1;			
$\xi_2  $ is the distance of the instantaneous centre of rotation from rail 2;			
$\ell$ is the span of the appliance;			
$e_j$ is the distance of the wheel pair $j$ from the relevant guidance means.			

**Table 2.9 — Definition of  $\lambda_{s,i,j,k}$  – values**

System	$\lambda_{s,j}$	$\lambda_{s,1,j,L}$	$\lambda_{s,1,j,T}$	$\lambda_{s,2,j,L}$	$\lambda_{s,2,j,T}$
CFF	$1 - \frac{\sum e_j}{nh}$	$\frac{\xi_1 \xi_2  }{n h}$	$\frac{\xi_2}{n} \left(1 - \frac{e_j}{h}\right)$	$\frac{\xi_1 \xi_2  }{n h}$	$\frac{\xi_1}{n} \left(1 - \frac{e_j}{h}\right)$
IFF		0	$\frac{\xi_2}{n} \left(1 - \frac{e_j}{h}\right)$	0	$\frac{\xi_1}{n} \left(1 - \frac{e_j}{h}\right)$
CFM	$\xi_2 \left(1 - \frac{\sum e_j}{nh}\right)$	$\frac{\xi_1 \xi_2  }{n h}$	$\frac{\xi_2}{n} \left(1 - \frac{e_j}{h}\right)$	$\frac{\xi_1 \xi_2  }{n h}$	0
IFM		0	$\frac{\xi_2}{n} \left(1 - \frac{e_j}{h}\right)$	0	0
Where:					
$n$ is the number of wheel pairs;					
$\xi_1  $ is the distance of the instantaneous centre of rotation from rail 1;					
$\xi_2  $ is the distance of the instantaneous centre of rotation from rail 2;					
$\ell$ is the span of the appliance;					
$e_j$ is the distance of the wheel pair $j$ from the relevant guidance means;					
$h$ is the distance between the instantaneous centre of rotation and the relevant guidance means.					

### **2.7.5 Horizontal force $H_{T,3}$ caused by acceleration or deceleration of the crab**

(1) The horizontal force  $H_{T,3}$  caused by acceleration or deceleration of the crab or trolley may be assumed to be covered by the horizontal force  $H_{B,2}$  given in 2.11.2.

### **2.8 Temperature effects**

(1)P The action effects on runways due to temperature variations shall be taken into account where necessary. In general, non-uniform distributed temperature need not be considered.

(2) For the temperature difference for outdoor runways see EN 1991-1-5.

### **2.9 Loads on access walkways, stairs, platforms and guard rails**

#### **2.9.1 Vertical loads**

(1) Unless otherwise stated, the access walkways, stairs and platforms should be loaded by a vertical load  $Q$  spread over a square surface of  $0,3\text{m} \times 0,3\text{m}$ .

(2) Where materials can be deposited a vertical load  $Q_k = 3 \text{ kN}$  should be applied.

(3) If the walkways, stairs and platforms are provided for access only, the characteristic value in (2) may be reduced to  $1,5 \text{ kN}$ .

(4) The vertical load  $Q_k$  may be disregarded if the structural member considered is subjected to crane actions.

#### **2.9.2 Horizontal loads**

(1) Unless otherwise stated, the guard rail should be loaded by a single horizontal load  $H_k = 0,3 \text{ kN}$ .

(2) The horizontal load  $H_k$  may be disregarded if all structural members are subjected to crane actions.

### **2.10 Test loads**

(1) When tests are performed after erection of the cranes on the supporting structures, the supporting structure should be checked against the test loading conditions.

(2) If relevant, the crane supporting structure should be designed for these test loads.

(3)P The hoist test load shall be amplified by a dynamic factor  $\phi_6$ .

(4) When considering test loads the following cases should be distinguished:

– Dynamic test load:

The test load is moved by the drives in the way the crane will be used. The test load should be at least  $110 \%$  of the nominal hoist load.

$$\varphi_6 = 0,5(1,0 + \varphi_2) \quad (2.13)$$

– Static test load:

The load is increased for testing by loading the crane without the use of the drives. The test load should be at least 125 % of the nominal hoist load.

$$\varphi_6 = 1,0 \quad (2.14)$$

## 2.11 Accidental actions

### 2.11.1 Buffer forces $H_{B,1}$ related to crane movement

(1)P Where buffers are used, the forces on the crane supporting structure arising from collision with the buffers shall be calculated from the kinetic energy of all relevant parts of the crane moving at 0,7 to 1,0 times the nominal speed.

(2) The buffer forces multiplied by  $\varphi_7$  according to Table 2.10, to make allowance for dynamic effects, may be calculated taking into account the distribution of relevant masses and the buffer characteristics, see Figure 2.9b.

$$H_{B,1} = \varphi_7 v_1 \sqrt{m_c S_B} \quad (2.15)$$

where:

- $\varphi_7$  see Table 2.10;
- $v_1$  is 70 % of the long travel velocity (m/s);
- $m_c$  is the mass of the crane and the hoist load (kg);
- $S_B$  is the spring constant of the buffer (N/m).

**Table 2.10 — Dynamic factor  $\varphi_7$**

Values of dynamic factor $\varphi_7$	Buffer characteristic
$\varphi_7 = 1,25$	$0,0 \leq \xi_b \leq 0,5$
$\varphi_7 = 1,25 + 0,7 (\xi_b - 0,5)$	$0,5 \leq \xi_b \leq 1$
NOTE: $\xi_b$ may be approximately determined from Figure 2.9	

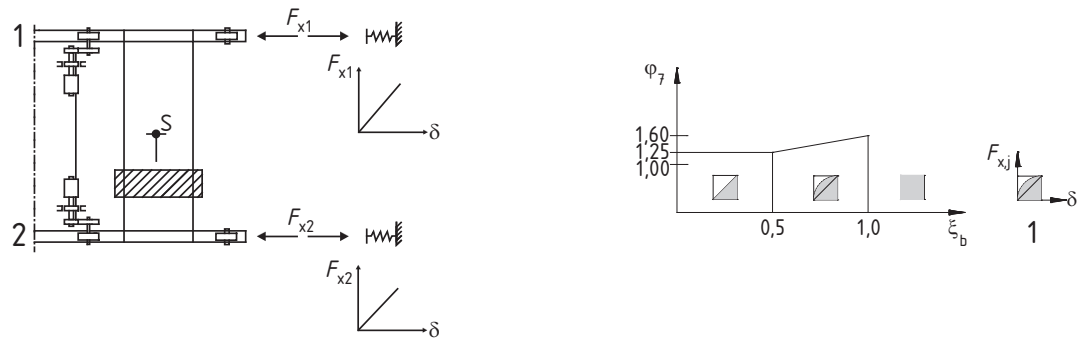

a) Buffer force

b) Buffer characteristic  $\xi_b = \frac{1}{F u} \int_0^u F du$ **Key**

1 Buffer characteristic

NOTE: For additional information about the characteristic of buffers see EN 13001-2.

**Figure 2.9 — Definition of the buffer force****2.11.2 Buffer forces  $H_{B,2}$  related to movements of the crab**

(1) Provided that the payload is free to swing, the horizontal load  $H_{B,2}$  representing the buffer forces related to movement of the crab or trolley may be taken as 10 % of the sum of the hoist load and the weight of the crab or trolley. In other cases the buffer force should be determined as for crane movement, see 2.11.1.

**2.11.3 Tilting forces**

(1)P If a crane with horizontally restrained loads can tilt when its load or lifting attachment collides with an obstacle, the resulting static forces shall be considered.

**2.12 Fatigue loads****2.12.1 Single crane action**

(1)P Fatigue loads shall be determined such that the operational conditions of the distribution of hoist loads and the effects of the variation of crane positions to the fatigue details are duly considered.

NOTE: Where sufficient information on the operational conditions is available, the fatigue loads may be determined according to EN 13001 and EN 1993-1-9, Annex A. Where this information is not available, or where a simplified approach is favoured, the following rules apply.

(2) For normal service conditions of the crane the fatigue loads may be expressed in terms of fatigue damage equivalent loads  $Q_e$  that may be taken as constant for all crane positions to determine fatigue load effects.

NOTE: The procedure is compatible with EN 13001 however it is a simplified approach for gantry girders to comply with incomplete information during the design stage.

(3) The fatigue damage equivalent load  $Q_e$  may be determined such that it includes the effects of the stress histories arising from the specified service conditions and the ratio of the absolute number of load cycles during the expected design life of the structure to the reference value  $N = 2,0 \times 10^6$  cycles.

**Table 2.11 — Classification of the fatigue actions from cranes according to EN 13001-1**

Class of load spectrum		$Q_0$	$Q_1$	$Q_2$	$Q_3$	$Q_4$	$Q_5$
		$\frac{kQ}{13} \leq 0,03$	$0,0313 < kQ \leq 0,0625$	$0,0625 < kQ \leq 0,125$	$0,125 < kQ \leq 0,25$	$0,25 < kQ \leq 0,5$	$0,5 < kQ \leq 1,0$
class of total number of cycles							
$U_0$	$C \leq 1,6 \cdot 10^4$	$S_0$	$S_0$	$S_0$	$S_0$	$S_0$	$S_0$
$U_1$	$1,6 \times 10^4 < C \leq 3,15 \times 10^4$	$S_0$	$S_0$	$S_0$	$S_0$	$S_0$	$S_1$
$U_2$	$3,15 \times 10^4 < C \leq 6,30 \times 10^4$	$S_0$	$S_0$	$S_0$	$S_0$	$S_1$	$S_2$
$U_3$	$6,30 \times 10^4 < C \leq 1,25 \times 10^5$	$S_0$	$S_0$	$S_0$	$S_1$	$S_2$	$S_3$
$U_4$	$1,25 \times 10^5 < C \leq 2,50 \times 10^5$	$S_0$	$S_0$	$S_1$	$S_2$	$S_3$	$S_4$
$U_5$	$2,50 \times 10^5 < C \leq 5,00 \times 10^5$	$S_0$	$S_1$	$S_2$	$S_3$	$S_4$	$S_5$
$U_6$	$5,00 \times 10^5 < C \leq 1,00 \times 10^6$	$S_1$	$S_2$	$S_3$	$S_4$	$S_5$	$S_6$
$U_7$	$1,00 \times 10^6 < C \leq 2,00 \times 10^6$	$S_2$	$S_3$	$S_4$	$S_5$	$S_6$	$S_7$
$U_8$	$2,00 \times 10^6 < C \leq 4,00 \times 10^6$	$S_3$	$S_4$	$S_5$	$S_6$	$S_7$	$S_8$
$U_9$	$4,00 \times 10^6 < C \leq 8,00 \times 10^6$	$S_4$	$S_5$	$S_6$	$S_7$	$S_8$	$S_9$

where:

$kQ$  is a load spectrum factor for all tasks of the crane;  
 $C$  is the total number of working cycles during the design life of the crane.

NOTE: The classes  $S_i$  are classified by the stress effect history parameter  $s$  in EN 13001-1 which is defined as:

$s = \nu k$  where:

$k$  is the stress spectrum factor;  
 $\nu$  is the number of stress cycles  $C$  related to  $2,0 \times 10^6$  stress cycles.

The classification is based on a total service life of 25 years.

(4) The fatigue load may be specified as:

$$Q_e = \varphi_{\text{fat}} \lambda_1 Q_{\text{max},i} \quad (2.16)$$

where:

$Q_{\text{max},i}$  is the maximum value of the characteristic vertical wheel load  $i$ ;  
 $\lambda_i = \lambda_{1,i} \lambda_{2,i}$  is the damage equivalent factor to make allowance for the relevant standardized fatigue load spectrum and absolute number of load cycles in relation to  $N = 2,0 \times 10^6$  cycles;

$$\lambda_{1,i} = \sqrt[m]{kQ} = \left[ \sum_j \left( \left( \frac{\Delta Q_{i,j}}{\max \Delta Q_i} \right)^m \frac{n_{i,j}}{\sum n_{i,j}} \right) \right]^{1/m} \quad (2.17)$$

$$\lambda_{2,i} = \sqrt[m]{nV} = \left[ \frac{\sum n_{i,j}}{N} \right]^{1/m} \quad (2.18)$$

where:

$\Delta Q_{i,j}$  is the load amplitude of range  $j$  for wheel  $i$ :  $\Delta Q_{i,j} = Q_{i,j} - Q_{\min,i}$ ;

$\max \Delta Q_i$  is the maximum load amplitude for wheel  $i$ :  $\max \Delta Q_i = Q_{\max,i} - Q_{\min,i}$ ;

$kQ, v$  are the damage equivalent factors;

$m$  is the slope of the fatigue strength curve;

$\varphi_{\text{fat}}$  is the damage equivalent dynamic impact factor, see (7);

$i$  is the number of the wheel

$N$  is  $2 \times 10^6$

NOTE: For the value of  $m$  see EN 1993-1-9, see also notes to Table 2.12.

(5) For determining the  $\lambda$ -value the use of cranes may be classified according to the load spectrum and the total number of load cycles as indicated in Table 2.11.

(6)  $\lambda$ -values may be taken from Table 2.12 according to the crane classification.

**Table 2.12 —  $\lambda$ -values according to the classification of cranes**

Classes S	S <sub>0</sub>	S <sub>1</sub>	S <sub>2</sub>	S <sub>3</sub>	S <sub>4</sub>	S <sub>5</sub>	S <sub>6</sub>	S <sub>7</sub>	S <sub>8</sub>	S <sub>9</sub>
normal stresses	0,198	0,250	0,315	0,397	0,500	0,630	0,794	1,00	1,260	1,587
shear stresses	0,379	0,436	0,500	0,575	0,660	0,758	0,871	1,00	1,149	1,320

NOTE 1: In determining the  $\lambda$ -values standardized spectra with a gaussian distribution of the load effects, the Miner rule and fatigue strength S-N lines with a slope  $m = 3$  for normal stresses and  $m = 5$  for shear stress have been used.

NOTE 2: In case the crane classification is not included in the specification documents of the crane indications are given in Annex B.

(7) The damage equivalent dynamic impact factor  $\varphi_{\text{fat}}$  for normal conditions may be taken as:

$$\varphi_{\text{fat},1} = \frac{1 + \varphi_1}{2} \quad \text{and} \quad \varphi_{\text{fat},2} = \frac{1 + \varphi_2}{2} \quad (2.19)$$

### 2.12.2 Stress range effects of multiple wheel or crane actions

(1) The stress range due to damage equivalent wheel loads  $Q_e$  may be determined from the evaluation of stress histories for the fatigue detail considered.

NOTE: For simplified approaches using the values  $\lambda_1$  from Table 2.12, see EN 1993-6, 9.4.2.3.

## **Section 3 Actions induced by machinery**

### **3.1 Field of application**

(1) This section applies to structures supporting rotating machines which induce dynamic effects in one or more planes.

(2) This section presents methods to determine the dynamic behaviour and action effects to verify the safety of the structure.

NOTE: Though a precise limit cannot be set, in general it may be assumed that for minor machinery with only rotating parts and weighing less than 5 kN or having a power less than 50 kW, the action effects are included in the imposed loads and separate considerations are therefore not necessary. In these cases the use of so called vibration absorbers under the supporting frame is sufficient to protect the machine and the surroundings. Examples are washing machines and small ventilators.

### **3.2 Classification of actions**

#### **3.2.1 General**

(1)P Actions from machinery are classified as permanent, variable and accidental actions which are represented by various models as described in 3.2.2 to 3.2.4.

#### **3.2.2 Permanent actions**

(1) Permanent actions during service include the self-weight of all fixed and moveable parts and static actions from service such as:

- self-weight of rotors and the hull (vertical);
- self-weight of condensers, if relevant, taking account of the water infill (vertical);
- actions from vacuum for turbines, the condensers of which are connected to the hull by compensators. (vertical and horizontal);
- drive torques of the machine transmitted to the foundation by the hull (pairs of vertical forces);
- forces from friction at the bearings induced by thermal expansion of the hull (horizontal);
- actions from self-weight, forces and moments from pipes due to thermal expansion, actions from gas; flow and gas pressure (vertical and horizontal);
- temperature effects from the machine and pipes, for instance temperature differences between machine and pipes and the foundation.

(2) Permanent actions during transient stages (erection, maintenance or repair) are those from self-weight only including those from hoisting equipments, scaffolding or other auxiliary devices.



### 3.2.3 Variable actions

(1) Variable actions from machinery during normal service are dynamic actions caused by accelerated masses such as:

- periodic frequency-dependent bearing forces due to eccentricities of rotating masses in all directions, mainly perpendicular to the axis of the rotors;
- free mass forces or mass moments;
- periodic actions due to service depending on the type of machine that are transmitted by the hull or bearings to the foundations;
- forces or moments due to switching on or off or other transient procedures such as synchronisations.

### 3.2.4 Accidental actions

(1) Accidental actions can occur from:

- accidental magnification of the eccentricity of masses (for instance by fracture of brakes or accidental deformation or rupture of axle of moveable parts);
- short circuit or out of synchronisation of the generators and machines;
- impact effects from pipes by shutting down.

### 3.3 Design situations

(1)P The relevant actions induced by machinery shall be determined for each design situation identified in accordance with EN 1990.

(2)P Design situations shall in particular be selected for verifying that:

- the service conditions of the machinery conform to the service requirements and no damage is induced to the structure supporting the machine and its foundation by accidental actions that would infringe the subsequent use of this structure for further service;
- the impact on the surroundings, for instance disturbance of sensitive equipment, is within acceptable limits;
- no ultimate limit state can occur in the structure;
- no fatigue limit state can occur in the structure.

NOTE: Unless specified otherwise, the serviceability requirements should be determined for the individual project.

### 3.4 Representation of actions

#### 3.4.1 Nature of the loads

(1)P In the determination of action effects a distinction shall be made between the static and the dynamic action effects.

(2)P In the static actions both those from machinery and those from the structure shall be included.

NOTE: Static actions from machinery are the permanent actions defined in 3.2.2. They may be used for determining creep effects or for verifying that prescribed limitations of static deformations are not exceeded.

(3)P The dynamic action effects shall be determined taking into account the interaction between the excitation from the machinery and the structure.

NOTE: The dynamic actions from the machinery are the variable actions defined in 3.2.3.

(4)P Dynamic action effects shall be determined by a dynamic calculation with an appropriate modelling of the vibration system and the dynamic action, see 3.4.2.

(5) Dynamic effects may be disregarded where not relevant.

### 3.4.2 Modelling of dynamic actions

(1) The dynamic actions of machines with only rotating parts, e.g. rotating compressors, turbines, generators and ventilators, consist of periodically changing forces which may be defined by a sinusoidal function, see Figure 3.1.

(2) A short circuit  $M_k(t)$  moment may be represented by a combination of sinusoidal moment-time diagrams acting between the rotor and the hull.

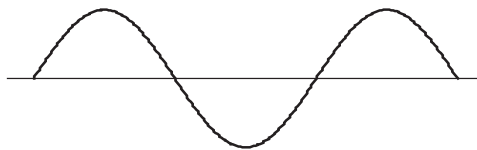

Figure 3.1 — Harmonic force

### 3.4.3 Modelling of the machinery-structure interaction

(1)P The vibration system composed of the machine and the structure shall be modelled such that the excitations, the mass quantities, stiffness properties and the damping are sufficiently taken into account to determine the actual dynamic behaviour.

(2) The model may be linear elastic with concentrated or distributed masses connected with springs and supported by springs.

(3) The common centre of gravity of the system (for instance of the foundation and machine) should be located as near as possible to the same vertical line as the centroid of the foundation area in contact with the soil. In any case the eccentricity in the distribution of masses should not exceed 5 % of the length of the side of the contact area. In addition, the centre of gravity of the machine and foundation system should if possible be below the top of the foundation block.

(4) In general the three possible degrees of freedom for translations and the three degrees of freedom for rotations should be considered; it is however in general not necessary to apply a three dimensional model.

(5) The properties of the supporting medium of the foundation structure should be converted in terms of the model (springs, damping constants etc.). The required properties are:

- for soils: dynamic G-modulus and damping constants;
- for piles: dynamic spring constants in vertical and horizontal directions
- for springs: spring constants in horizontal and vertical directions and for rubber springs the damping data.

### 3.5 Characteristic values

(1) A complete survey of the static and dynamic forces for the various design situations should be obtained from the machine manufacturer together with all other machine data such as outline drawings, weights of static and moving parts, speeds, balancing etc.

(2) The following data should be obtained from the machine manufacturer:

- loading diagram of the machine showing the location, magnitude and direction of all loads including dynamic loads;
- speed of the machine;
- critical speeds of the machine;
- outline dimensions of the foundation;
- mass moment of inertia of the machine components;
- details of inserts and embedments;
- layout of piping, ducting etc, and their supporting details;
- temperatures in various zones during operation;
- allowable displacements at the machine bearing points during normal operation.

(3) In simple cases, the dynamic forces (free forces) for rotating machine parts may be determined as follows:

$$F_s = m_R \omega_r^2 e_M = m_R \omega_r (\omega_r e_M) \quad (3.1)$$

where:

$F_s$  is the free force of the rotor;

$m_R$  is the mass of the rotor;

$\omega_r$  is the circular frequency of the rotor (rad/s);

$e_M$  is the eccentricity of the rotor mass;

$\omega_r e$  is the accuracy of balancing of the rotor, expressed as a velocity amplitude.

(4) For the accuracy of balancing, the following situations should be considered:

– persistent situation:

the machine is well balanced. However, with time the balance of the machines decreases to a degree that is just acceptable for normal operation. A warning system on the machine ensures that the operator is warned in case of exceeding a certain limit. Up to that state of balance no detrimental vibration may occur to the structure and the surroundings and the requirements concerning the vibration level are to be fulfilled.

– accidental situation:

the balance is completely disturbed by an accidental event: the monitoring system ensures the switch off of the machine. The structure is to be strong enough to withstand the dynamic forces.

(5) In simple cases the interaction effect from the excitation of a machine with a rotating mass and the dynamic behaviour of the structure may be expressed by a static equivalent force:

$$F_{\text{eq}} = F_s \varphi_M \quad (3.2)$$

where:

$F_s$  is the free force of the rotor;

$\varphi_M$  is the dynamic factor which depends on the ratio of the natural frequency  $n_e$  (or  $\omega_e$ ) of the structure to the frequency of the exciting force  $n_s$  (or  $\omega_s$ ) and the damping ratio  $\zeta$ .

(6) For harmonically varying forces (free forces of rotating equipment) the magnification factor may be calculated in the following way:

a) for small damping or far from resonance

$$\varphi_M = \frac{\omega_e^2}{\omega_e^2 - \omega_s^2} \quad (3.3)$$

b) in case of resonance  $\omega_e = \omega_s$  and a damping ratio  $\zeta$

$$\varphi_M = \left[ \left( 1 - \frac{\omega_s^2}{\omega_e^2} \right)^2 + \left( 2\zeta \frac{\omega_s}{\omega_e} \right)^2 \right]^{-1/2} \quad (3.4)$$

(7) If the time history of the short circuit moment  $M_k(t)$  is not indicated by the manufacturer, the following expression may be used:

$$M_k(t) = 10 M_o \left( e_m^{-\frac{t}{0.4}} \sin \Omega_N t - \frac{1}{2} e_m^{-\frac{t}{0.4}} \sin 2\Omega_N t \right) - M_o \left( 1 - e_m^{-\frac{t}{0.15}} \right) \quad (3.5)$$

where:

$M_o$  is the nominal moment resulting from the effective power;

$\Omega_N$  is the angular frequency of the electric circuit (rad/s);

$t$  is the time (s).

(8) For natural frequencies in the range  $0,95 \Omega_N$  to  $1,05 \Omega_N$  the calculated frequencies of the electric circuit should be identical with these natural frequencies.

(9) As a simplification, an equivalent static moment may be calculated in the following way:

$$M_{k,eq} = 1,7 M_{k,max} \quad (3.6)$$

where:

$M_{k,max}$  is the peak value of the circuit moment  $M_k(t)$ .

(10) If no indication on  $M_{k,max}$  is given from the manufacturer the following value may be used:

$$M_{k,max} = 12 M_o \quad (3.7)$$

### 3.6 Serviceability criteria

(1) Serviceability criteria are, in general, related to vibration movements of:

- a) the axis of the machine and its bearings;
- b) extreme points of the structure and the machinery.

(2) Characteristics of the movements are:

- the displacement amplitude  $A$ ;
- the velocity amplitude  $\omega_s A$ ;
- the acceleration amplitude  $\omega_s^2 A$ .

(3)P In calculating the amplitudes of the system, the translational vibrations as well as the rotational vibrations caused by the dynamic forces and moments shall be taken into account and also the range of the stiffness properties of the foundation and the supporting medium (soil, piles).

(4) In the simple case of a one mass spring system, see Figure 3.2, the displacement amplitudes may be calculated as follows:

$$A = \frac{F_{eq}}{k} \quad (3.8)$$

where:

$k$  is the spring constant of the system.

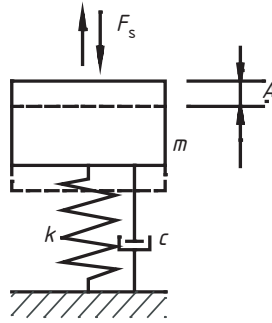

**Figure 3.2 — Mass spring system**

## Annex A (normative)

### Basis of design – supplementary clauses to EN 1990 for runway beams loaded by cranes

#### A.1 General

(1) This annex gives rules on partial factors for actions ( $\gamma$  factors), and on combinations of crane loads on runway beams with permanent actions, quasistatic wind, snow and temperature actions and on the relevant  $\psi$  factors.

(2) If other actions need to be considered (for instance mining subsidence) the combinations should be supplemented to take them into account. The combinations should also be supplemented and adapted for the execution phases.

(3) When combining a group of crane loads together with other actions, the group of crane loads should be considered as a single action.

(4) When considering combinations of actions due to crane loads with other actions the following cases should be distinguished:

- runways outside buildings;
- runways inside buildings where climatic actions are resisted by the buildings and structural elements of the buildings may also be loaded directly or indirectly by crane loads.

(5) For runways outside buildings the characteristic wind action on the crane structure and on the hoisting equipment may be assessed in accordance with EN 1991-1-4 as a characteristic force  $F_{wk}$ .

(6) When considering combinations of hoist loads with wind action, the maximum wind force compatible with crane operations should also be considered. This force  $F_w^*$  is associated with a wind speed equal to 20 m/s. The reference area  $A_{ref,x}$  for the hoist load should be determined for each specific case.

(7) For runways inside buildings, wind actions and snow loads on the crane structure may be neglected; however in structural parts of the building that are loaded by wind, snow and crane loads the appropriate load combinations should be considered.

#### A.2 Ultimate limit states

##### A.2.1 Combinations of actions

(1) For each critical load case, the design values of the effects of actions should be determined by combining the values of actions which occur simultaneously in accordance with EN 1990.

(2) Where an accidental action is to be considered no other accidental action nor wind nor snow action need be considered to occur simultaneously.

### A.2.2 Partial factors

(1) For ULS verifications governed by the strength of structural material or of the ground, the partial factors on actions for ultimate limit states in the persistent, transient and accidental design situations should be defined. For case EQU, see (2) below.

NOTE: The values of the  $\gamma$ -factors may be set in the National Annex. For the design of runway beams the  $\gamma$ -values given in Table A.1 are recommended. They cover cases STR and GEO specified for buildings in 6.4.1(1) of EN 1990.

**Table A.1 — Recommended values of  $\gamma$ -factors**

Action	Symbol	Situation	
		P/T	A
<b>Permanent crane actions</b>			
- unfavourable	$\gamma_{G\text{sup}}$	1,35	1,00
- favourable	$\gamma_{G\text{inf}}$	1,00	1,00
<b>Variable crane actions</b>			
- unfavourable	$\gamma_{Q\text{sup}}$	1,35	1,00
- favourable	$\gamma_{Q\text{inf}}$		
crane present		1,00	1,00
crane not present		0,00	0,00
<b>Other variable actions</b>	$\gamma_Q$		
- unfavourable		1,50	1,00
- favourable		0,00	0,00
<b>Accidental actions</b>	$\gamma_A$		1,00

P - Persistent situation T - Transient situation A - Accidental situation

(2) For verifications with regard to loss of static equilibrium EQU and uplift of bearings, the favourable and unfavourable parts of crane actions should be considered as individual actions. Unless otherwise specified (see in particular the relevant design Eurocodes) the unfavourable and favourable parts of permanent actions should be associated with  $\gamma_{G\text{sup}}$  and  $\gamma_{G\text{inf}}$  respectively.

NOTE: The values of the  $\gamma$ -factors may be set in the National Annex. The following  $\gamma$ -values are recommended:

$$\gamma_{G\text{sup}} = 1,05$$

$$\gamma_{G\text{inf}} = 0,95$$

The other  $\gamma$ -factors on actions (especially on variable actions) are as in (1).

### A.2.3 $\psi$ -factors for crane loads

(1)  $\psi$ -factors for crane loads are as given in Table A.2.



**Table A.2 —  $\psi$ -factors for crane loads**

Action	Symbol	$\psi_0$	$\psi_1$	$\psi_2$
Single crane or groups of loads induced by cranes	$Q_r$	$\psi_0$	$\psi_1$	$\psi_2$

NOTE: The National Annex may specify the  $\psi$ -factors. The following  $\psi$ -factors are recommended:

$$\psi_0 = 1,0$$

$$\psi_1 = 0,9$$

$\psi_2$  = ratio between the permanent crane action and the total crane action.

### A.3 Serviceability limit states

#### A.3.1 Combinations of actions

(1) For verification of serviceability limit states the various combinations should be taken from EN 1990.

(2) When tests are performed, the test loading of the crane, see 2.10, should be considered as the crane action.

#### A.3.2 Partial factors

(1) In serviceability limit states the partial factor for actions on crane supporting structures should be taken as 1,0 unless otherwise specified.

#### A.3.3 $\psi$ -factors for crane actions

(1)  $\psi$ -factors are given in Table A.2.

### A.4 Fatigue

(1) The verification rules for fatigue depend on the fatigue load model to be used and are specified in the design Eurocodes.

## Annex B (informative)

### Guidance for crane classification for fatigue

**Table B.1 — Recommendations for loading classes**

Item	Type of crane	Hoisting class	S-classes
1	Hand-operated cranes	HC 1	S0, S1
2	Assembly cranes	HC1, HC2	S0, S1
3	Powerhouse cranes	HC1	S1, S2
4	Storage cranes - with intermittennd operation	HC2	S4
5	Storage cranes, spreader bar cranes, scrap yard cranes -with continuous operation	HC3, HC4	S6 ,S7
6	Workshop cranes	HC2, HC3	S3,S4
7	Overhead travelling cranes, ram cranes - with grab or magnet operation	HC3, HC4	S6, S7
8	Casting cranes	HC2, HC3	S6, S7
9	Soaking pit cranes	HC3, HC4	S7, S8
10	Stripper cranes, charging cranes	HC4	S8, S9
11	Forging cranes	HC4	S6, S7
12	Transporter bridges, semi-portal cranes, portal cranes with trolley or slewing crane - with hook operation	HC2	S4, S5
13	Transporter bridges, semi-portal cranes, portal cranes with trolley or slewing crane – with grab or magnet operation	HC3, HC4	S6, S7
14	Travelling belt bridge with fixed or sliding belt(s)	HC1	S3, S4
15	Dockyard cranes, slipway cranes, fitting-out cranes - with hook operation	HC2	S3, S4
16	Wharf cranes, slewing, floating cranes, level luffing slewing - with hook operation	HC2	S4, S5
17	Wharf cranes, slewing, floating cranes, level luffing slewing - with grab or magnet operation	HC3, HC4	S6, S7
18	Heavy duty floating cranes, gantry cranes	HC1	S1, S2
19	Shipboard cargo cranes - with hook operation	HC2	S3, S4
20	Shipboard cargo cranes - with grab or magnet operation	HC3, HC4	S4, S5
21	Tower slewing cranes for the construction industry	HC1	S2, S3
22	Erection cranes, derrick cranes - with hook operation	HC1, HC2	S1, S2
23	Rail mounted slewing cranes - with hook operation	HC2	S3, S4
24	Rail mounted slewing cranes - with grab or magnet operation	HC3, HC4	S4, S5
25	Railway cranes authorised on trains	HC2	S4
26	Truck cranes, mobile cranes - with hook operation	HC2	S3, S4
27	Truck cranes, mobile cranes - with grab or magnet operation	HC3, HC4	S4, S5
28	Heavy duty truck cranes, heavy duty mobile cranes	HC1	S1, S2



---

---

## BSI — British Standards Institution

BSI is the independent national body responsible for preparing British Standards. It presents the UK view on standards in Europe and at the international level. It is incorporated by Royal Charter.

### Revisions

British Standards are updated by amendment or revision. Users of British Standards should make sure that they possess the latest amendments or editions.

It is the constant aim of BSI to improve the quality of our products and services. We would be grateful if anyone finding an inaccuracy or ambiguity while using this British Standard would inform the Secretary of the technical committee responsible, the identity of which can be found on the inside front cover.  
Tel: +44 (0)20 8996 9000. Fax: +44 (0)20 8996 7400.

BSI offers members an individual updating service called PLUS which ensures that subscribers automatically receive the latest editions of standards.

### Buying standards

Orders for all BSI, international and foreign standards publications should be addressed to Customer Services. Tel: +44 (0)20 8996 9001.  
Fax: +44 (0)20 8996 7001. Email: [orders@bsi-global.com](mailto:orders@bsi-global.com). Standards are also available from the BSI website at <http://www.bsi-global.com>.

In response to orders for international standards, it is BSI policy to supply the BSI implementation of those that have been published as British Standards, unless otherwise requested.

### Information on standards

BSI provides a wide range of information on national, European and international standards through its Library and its Technical Help to Exporters Service. Various BSI electronic information services are also available which give details on all its products and services. Contact the Information Centre.  
Tel: +44 (0)20 8996 7111. Fax: +44 (0)20 8996 7048. Email: [info@bsi-global.com](mailto:info@bsi-global.com).

Subscribing members of BSI are kept up to date with standards developments and receive substantial discounts on the purchase price of standards. For details of these and other benefits contact Membership Administration.  
Tel: +44 (0)20 8996 7002. Fax: +44 (0)20 8996 7001.  
Email: [membership@bsi-global.com](mailto:membership@bsi-global.com).

Information regarding online access to British Standards via British Standards Online can be found at <http://www.bsi-global.com/bsonline>.

Further information about BSI is available on the BSI website at <http://www.bsi-global.com>.

### Copyright

Copyright subsists in all BSI publications. BSI also holds the copyright, in the UK, of the publications of the international standardization bodies. Except as permitted under the Copyright, Designs and Patents Act 1988 no extract may be reproduced, stored in a retrieval system or transmitted in any form or by any means – electronic, photocopying, recording or otherwise – without prior written permission from BSI.

This does not preclude the free use, in the course of implementing the standard, of necessary details such as symbols, and size, type or grade designations. If these details are to be used for any other purpose than implementation then the prior written permission of BSI must be obtained.

Details and advice can be obtained from the Copyright & Licensing Manager.  
Tel: +44 (0)20 8996 7070. Fax: +44 (0)20 8996 7553.  
Email: [copyright@bsi-global.com](mailto:copyright@bsi-global.com).