

Flexible sheets for waterproofing — Bitumen, plastic and rubber sheets for roof waterproofing — Determination of watertightness

The European Standard EN 1928:2000 has the status of a
British Standard

ICS 75.140; 83.140.10; 91.100.50

National foreword

This British Standard is the official English language version of EN 1928:2000.

The UK participation in its preparation was entrusted by Technical Committee B/546, Flexible sheets for waterproofing, to Subcommittee B/546/1, Bituminous roofing felts, which has the responsibility to:

- aid enquirers to understand the text;
- present to the responsible European committee any enquiries on the interpretation, or proposals for change, and keep the UK interests informed;
- monitor related international and European developments and promulgate them in the UK.

A list of organizations represented on this subcommittee can be obtained on request to its secretary.

Cross-references

The British Standards which implement international or European publications referred to in this document may be found in the BSI Standards Catalogue under the section entitled “International Standards Correspondence Index”, or by using the “Find” facility of the BSI Standards Electronic Catalogue.

A British Standard does not purport to include all the necessary provisions of a contract. Users of British Standards are responsible for their correct application.

Compliance with a British Standard does not of itself confer immunity from legal obligations.

Summary of pages

This document comprises a front cover, an inside front cover, the EN title page, pages 2 to 8, an inside back cover and a back cover.

The BSI copyright notice displayed in this document indicates when the document was last issued.

Amendments issued since publication

Amd. No.	Date	Comments

This British Standard, having been prepared under the direction of the Sector Committee for Building and Civil Engineering, was published under the authority of the Standards Committee and comes into effect on 15 September 2000

© BSI 09-2000

ISBN 0 580 36351 1

EUROPEAN STANDARD

EN 1928

NORME EUROPÉENNE

EUROPÄISCHE NORM

March 2000

ICS 91.100.50

English version

Flexible sheets for waterproofing - Bitumen, plastic and rubber sheets for roof waterproofing - Determination of watertightness

Feuilles souples d'étanchéité - Feuilles d'étanchéité de toiture bitumineuses, plastiques et élastomères - Détermination de l'étanchéité à l'eau

Abdichtungsbahnen - Bitumen-, Kunststoff- und Elastomerbahnen für Dachabdichtungen - Bestimmung der Wasserdichtheit

This European Standard was approved by CEN on 17 February 2000.

CEN members are bound to comply with the CEN/CENELEC Internal Regulations which stipulate the conditions for giving this European Standard the status of a national standard without any alteration. Up-to-date lists and bibliographical references concerning such national standards may be obtained on application to the Central Secretariat or to any CEN member.

This European Standard exists in three official versions (English, French, German). A version in any other language made by translation under the responsibility of a CEN member into its own language and notified to the Central Secretariat has the same status as the official versions.

CEN members are the national standards bodies of Austria, Belgium, Czech Republic, Denmark, Finland, France, Germany, Greece, Iceland, Ireland, Italy, Luxembourg, Netherlands, Norway, Portugal, Spain, Sweden, Switzerland and United Kingdom.



EUROPEAN COMMITTEE FOR STANDARDIZATION
COMITÉ EUROPÉEN DE NORMALISATION
EUROPÄISCHES KOMITEE FÜR NORMUNG

Central Secretariat: rue de Stassart, 36 B-1050 Brussels

Contents

	Page
Foreword	3
Introduction	3
1 Scope	3
2 Normative references	3
3 Definitions	3
4 Principle	4
5 Apparatus	4
6 Sampling	7
7 Test specimens	7
8 Procedure	7
9 Expression of results and precision	8
10 Test report	8
Bibliography	8

Foreword

This European Standard has been prepared by Technical Committee CEN/TC 254, Flexible sheets for waterproofing, the Secretariat of which is held by BSI.

This European Standard shall be given the status of a national standard, either by publication of an identical text or by endorsement, at the latest by September 2000, and conflicting national standards shall be withdrawn at the latest by September 2000.

According to the CEN/CENELEC Internal Regulations, the national standards organizations of the following countries are bound to implement this European Standard: Austria, Belgium, Czech Republic, Denmark, Finland, France, Germany, Greece, Iceland, Ireland, Italy, Luxembourg, Netherlands, Norway, Portugal, Spain, Sweden, Switzerland and the United Kingdom.

Introduction

This standard has been prepared by the Technical Committee CEN/TC 254 to determine the watertightness of sheets for waterproofing.

This standard has been prepared for applications in roofing but it may also be used in other areas where it is relevant.

This standard is intended for characterization of flexible sheets for waterproofing as manufactured or supplied before use. This standard relates exclusively to products and not to waterproofing membrane systems composed of such products and installed in the works.

1 Scope

This European Standard applies to bitumen, plastic and rubber sheets for roof waterproofing and specifies procedures for determining the watertightness, i.e. the resistance to ponding water or to hydraulic pressure absorbed by a limited part of the surface, of factory made products.

This standard may also be used in other waterproofing areas.

2 Normative references

This European Standard incorporates by dated or undated reference, provisions from other publications. These normative references are cited at the appropriate places in the text and the publications are listed hereafter. For dated references, subsequent amendments to or revisions of these publications apply to this draft European Standard only when incorporated in it by amendment or revision. For undated references the latest edition of the publication referred to applies.

prEN 13416:1999

Flexible sheets for waterproofing - Bitumen, plastic and rubber sheets for roof waterproofing - Rules for sampling.

3 Definitions

For the purpose of this standard, the following definitions apply.

3.1 upper side: the upperside of the sheets, as laid, usually the inside of the roll

3.2 watertightness: condition of flexible sheet for waterproofing if:

- a) in case of method A: no discoloration is observed of the filter paper above the surface of a test specimen at the applied water pressure during the total test period
- b) in case of method B: the applied maximum pressure does not drop by more than 5 % of the initial value

4 Principle

Due to the nature of the bitumen, plastic or rubber sheets concerned, the test procedure given in this standard consists of two methods.

4.1 Method A

Test procedure for sheets intended for use in low pressure application, e.g. roofing, underlay, vapour control layer. The specimen is subjected to a pressure up to 60 kPa for 24 h.

4.2 Method B

Test procedure for sheets intended for use in high pressure application, e.g. special roofs, tunnelling and tanking. Submission of a test specimen to a specified water pressure for 24 h against a disk containing four slots of specified form and dimensions. The test specimen is observed to establish whether it remains watertight.

5 Apparatus

5.1 Method A

A cylindrical metal flanged box, with a 150 mm diameter aperture, is connected to an open ended pipe or vessel which rises to a height of not less than 1 m, generally as shown in Figure 1.

Dimensions in millimetres

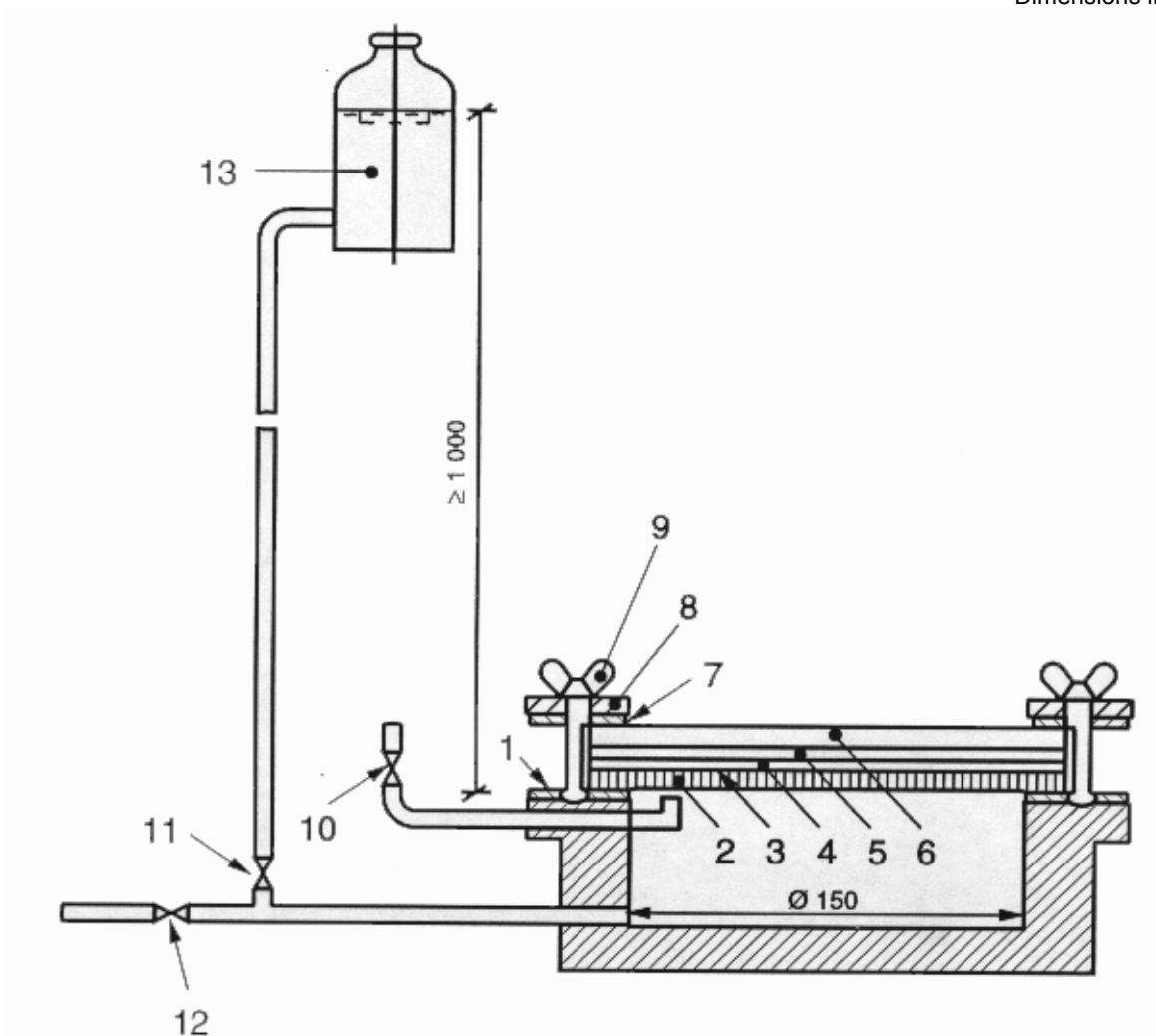

Key

- 1 Lower rubber sealing gasket
- 2 Test specimen inserted such that the surface normally exposed to the weather/water will be in contact with the water under test
- 3 Laboratory filter paper
- 4 Moisture indicating mixture uniformly spread over surface of test specimen. A moisture passing through the test specimen is readily detected using an indicator consisting of a mixture of fine white (icing) sugar (99,5 %) and methylene blue dye (0,5 %) sieved over a 0,074 mm mesh and dried over calcium chloride in a desiccator
- 5 Laboratory filter paper
- 6 Circular ordinary window glass sheet:
- 5 mm thick for pressure of water \leq 10 kPa
- 8 mm thick for pressure of water \leq 60 kPa
- 7 Upper rubber sealing gasket
- 8 Steel clamping ring
- 9 Wing nuts
- 10 Air exhaust valve
- 11 Water inlet valve
- 12 Water supply and draining valve
- 13 Means to apply and control pressure up to 60 kPa

Figure 1 - Apparatus for watertightness test at low pressures

5.2 Method B

The apparatus consists of a device (see Figures 2 and 3) by which a pressure can be applied to one side of a test specimen.

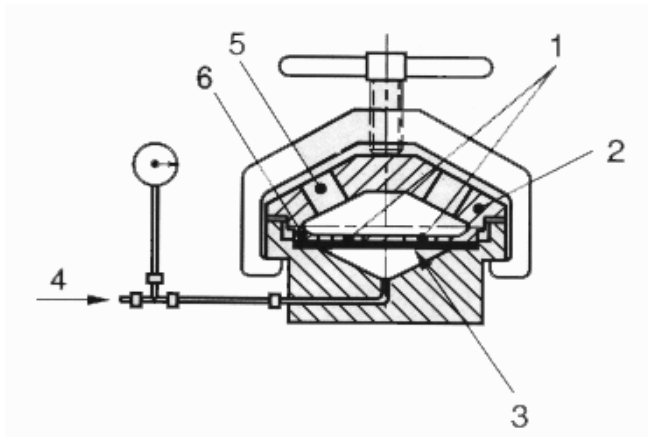

Key

- 1 Slots
- 2 Cover
- 3 Test specimen
- 4 Hydrostatic pressure
- 5 Observation gap
- 6 Slotted plate

Figure 2 - Slot pressure testing device for watertightness at high pressures

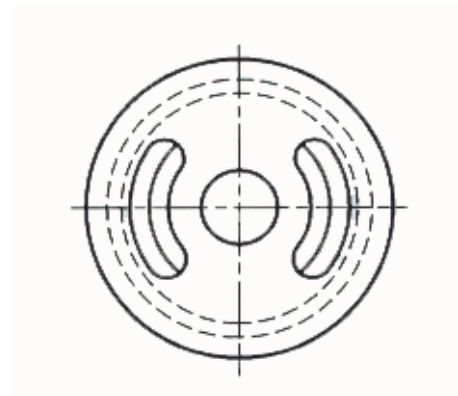
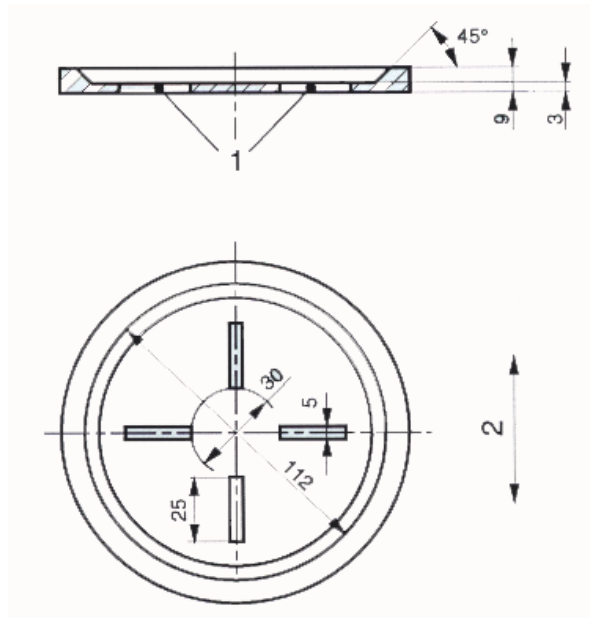

Figure 3 - Device for the slot pressure test: Sketch of the cover

The test specimen is covered by a circular disk containing four slots. The form and dimensions of the slots are specified by the requirements indicated in Figure 4.

Dimensions in millimetres



Key

- 1 All edges of the slotted plate are rounded to a radius of 0,5 mm approximately
- 2 Longitudinal direction of the membrane

Figure 4 - Slotted plate

6 Sampling

Test samples shall be taken in accordance with prEN 13416:1999.

7 Test specimens

7.1 Preparation

The specimens shall be taken evenly distributed across the width of the sheet, the outer ones 100 mm from the edges. The longitudinal direction on the test specimens shall be marked parallel to direction of production.

The number of test specimens shall be as specified in the relevant product standard, but shall be a minimum of three.

7.2 Dimensions of the test specimens

7.2.1 Method A

Circular test specimens with a diameter of (200 ± 2) mm.

7.2.2 Method B

Circular test specimens with a diameter equal to the external diameter of the slotted plate (approximately 130 mm).

7.3 Conditioning of test specimens

The test specimens shall be stored for at least 6 h at (23 ± 5) °C prior to testing.

8 Procedure

8.1 Test conditions

The test shall be carried out at (23 ± 5) °C. In case of dispute it shall be carried out at (23 ± 2) °C and (50 ± 5) % relative humidity (RH).

The test pressure shall be specified in the product specification. It shall be ensured that the margins are watertight.

8.2 Procedure method A

Insert the test specimen into the apparatus (5.1). Tighten the wing nuts (9) firmly onto the clamping ring. Open the valve (11) to let water in while valve (10) is left open to allow air to escape. Close valve (10) once water passes through indicating that the apparatus is filled.

Apply the required pressure to the upper side of the test specimen.

Maintain the pressure for a period of (24 ± 1) h.

Inspect the test specimen to see if there has been discoloration of the upper filter paper.

8.3 Procedure method B

Fill the apparatus in accordance with Figure 2 with water until overflowing. Purge the water line thoroughly.

Place the test specimen with its upper side downwards in the apparatus and cover with the specified slotted plate, one of the slots (see Figure 4) being parallel to the longitudinal direction of the sheet. Place the cover and progressively tighten until the specimen is tightly in place. Dry the non-exposed side of the specimen with a cloth or with compressed air. Pressurize progressively to the specified test pressure.

Once the test pressure is reached, maintain the pressure for a period of (24 ± 1) h.

Observe the watertightness of the test specimen after the testing time (sudden pressure drop or presence of water on the non-exposed face of the test specimen).

9 Expression of results and precision

9.1 Expression of results

9.1.1 Method A

Any specimen with evidence of water penetration through to the upper filter paper is deemed to have failed the test.

The sheet is deemed to be watertight when all specimens pass the test.

9.1.2 Method B

The watertightness test is considered passed if all test specimens remain watertight after the specified testing time.

9.2 Precision

Precision is not specified by this standard.

NOTE No report on inter-laboratory tests of repeatability and reproducibility is available.

10 Test report

The test report shall include at least the following information:

- a) all details necessary to identify the product tested;
- b) a reference to this European Standard (EN 1928) and any deviation from it;
- c) information on sampling in accordance with clause 6;
- d) details of preparation of test specimens in accordance with clause 7;
- e) test procedure indicating method A or B used, including the test pressure and any deviation;
- f) the test results in accordance with clause 9;
- g) the dates of the tests.

Bibliography

- [1] UEAtc M.O.A.T No. 27:1983 "General Directive for the Assessment of Roof Waterproofing Systems"
- [2] DIN 16726:1986-12
Kunststoff-Dachbahnen, Kunststoff-Dichtungsbahnen, Prüfung
(Plastic roofing sheets - plastic sheets for waterproofing - testing)

BSI — British Standards Institution

BSI is the independent national body responsible for preparing British Standards. It presents the UK view on standards in Europe and at the international level. It is incorporated by Royal Charter.

Revisions

British Standards are updated by amendment or revision. Users of British Standards should make sure that they possess the latest amendments or editions.

It is the constant aim of BSI to improve the quality of our products and services. We would be grateful if anyone finding an inaccuracy or ambiguity while using this British Standard would inform the Secretary of the technical committee responsible, the identity of which can be found on the inside front cover. Tel: 020 8996 9000. Fax: 020 8996 7400.

BSI offers members an individual updating service called PLUS which ensures that subscribers automatically receive the latest editions of standards.

Buying standards

Orders for all BSI, international and foreign standards publications should be addressed to Customer Services. Tel: 020 8996 9001. Fax: 020 8996 7001.

In response to orders for international standards, it is BSI policy to supply the BSI implementation of those that have been published as British Standards, unless otherwise requested.

Information on standards

BSI provides a wide range of information on national, European and international standards through its Library and its Technical Help to Exporters Service. Various BSI electronic information services are also available which give details on all its products and services. Contact the Information Centre. Tel: 020 8996 7111. Fax: 020 8996 7048.

Subscribing members of BSI are kept up to date with standards developments and receive substantial discounts on the purchase price of standards. For details of these and other benefits contact Membership Administration. Tel: 020 8996 7002. Fax: 020 8996 7001.

Copyright

Copyright subsists in all BSI publications. BSI also holds the copyright, in the UK, of the publications of the international standardization bodies. Except as permitted under the Copyright, Designs and Patents Act 1988 no extract may be reproduced, stored in a retrieval system or transmitted in any form or by any means – electronic, photocopying, recording or otherwise – without prior written permission from BSI.

This does not preclude the free use, in the course of implementing the standard, of necessary details such as symbols, and size, type or grade designations. If these details are to be used for any other purpose than implementation then the prior written permission of BSI must be obtained.

If permission is granted, the terms may include royalty payments or a licensing agreement. Details and advice can be obtained from the Copyright Manager. Tel: 020 8996 7070.