

Personal protective equipment for the prevention of falls from a height — Low stretch kernmantel ropes

The European Standard EN 1891:1998 has the status of a
British Standard

ICS 13.340.99

National foreword

This British Standard is the English language version of EN 1891:1998.

The UK participation in its preparation was entrusted to Technical Committee PH/5, Industrial safety belts and harnesses, which has the responsibility to:

- aid enquirers to understand the text;
- present to the responsible European committee any enquiries on the interpretation, or proposals for change, and keep the UK interests informed;
- monitor related international and European developments and promulgate them in the UK.

A list of organizations represented on this committee can be obtained on request to its secretary.

Cross-references

The British Standards which implement international or European publications referred to in this document may be found in the BSI Standards Catalogue under the section entitled "International Standards Correspondence Index", or by using the "Find" facility of the BSI Standards Electronic Catalogue.

A British Standard does not purport to include all the necessary provisions of a contract. Users of British Standards are responsible for their correct application.

Compliance with a British Standard does not of itself confer immunity from legal obligations.

Summary of pages

This document comprises a front cover, an inside front cover, the EN title page, pages 2 to 16, an inside back cover and a back cover.

Amendments issued since publication

Amd. No.	Date	Text affected

This British Standard, having been prepared under the direction of the Health and Environment Sector Board, was published under the authority of the Standards Board and comes into effect on 15 September 1998

© BSI 1998

EUROPEAN STANDARD

EN 1891

NORME EUROPÉENNE

EUROPÄISCHE NORM

April 1998

ICS 13.340.99

Descriptors: Personal protective equipment, accident prevention, protection against fall, ropes, textiles, definitions, specifications, characteristics, elongation, sliding, tests, marking, information

English version

Personal protective equipment for the prevention of falls from a height — Low stretch kernmantel ropes

Équipement de protection individuelle pour la prévention des chutes de hauteur — Cordes tressées gainées à faible coefficient d'allongement

Persönliche Schutzausrüstung zur Verhinderung von Abstürzen — Kernmantelseile mit geringer Dehnung

This European Standard was approved by CEN on 25 March 1998.

CEN members are bound to comply with the CEN/CENELEC Internal Regulations which stipulate the conditions for giving this European Standard the status of a national standard without any alteration. Up-to-date lists and bibliographical references concerning such national standards may be obtained on application to the Central Secretariat or to any CEN member.

This European Standard exists in three official versions (English, French, German). A version in any other language made by translation under the responsibility of a CEN member into its own language and notified to the Central Secretariat has the same status as the official versions.

CEN members are the national standards bodies of Austria, Belgium, Czech Republic, Denmark, Finland, France, Germany, Greece, Iceland, Ireland, Italy, Luxembourg, Netherlands, Norway, Portugal, Spain, Sweden, Switzerland and United Kingdom.

CEN

European Committee for Standardization
Comité Européen de Normalisation
Europäisches Komitee für Normung

Central Secretariat: rue de Stassart 36, B-1050 Brussels

© 1998 CEN All rights of exploitation in any form and by any means reserved worldwide for CEN national Members.

Ref. No. EN 1891:1998 E

Foreword

This European Standard has been prepared by Technical Committee CEN/TC 160, Protection against falls from height including working belts, the secretariat of which is held by DIN.

This European Standard shall be given the status of a national standard, either by publication of an identical text or by endorsement, at the latest by October 1998, and conflicting national standards shall be withdrawn at the latest by October 1998.

This European Standard has been prepared under a mandate given to CEN by the European Commission and the European Free Trade Association, and supports essential requirements of EU Directive(s).

For relationship with EU Directive(s), see informative annex ZA, which is an integral part of this standard.

The annex A is informative.

According to the CEN/CENELEC Internal Regulations, the national standards organizations of the following countries are bound to implement this European Standard: Austria, Belgium, Czech Republic, Denmark, Finland, France, Germany, Greece, Iceland, Ireland, Italy, Luxembourg, Netherlands, Norway, Portugal, Spain, Sweden, Switzerland and the United Kingdom.

Contents

	Page
Foreword	2
0 Introduction	3
1 Scope	3
2 Normative references	3
3 Definitions	3
3.1 Low stretch kernmantel rope	3
3.2 Rope access	3
3.3 Work positioning	3
3.4 Type A ropes	3
3.5 Type B ropes	3
4 Requirements	3
4.1 Materials	3
4.2 Rope diameter D	3
4.3 Knotability K	3
4.4 Sheath slippage S_s	4
4.5 Elongation E	4
4.6 Shrinkage R	4
4.7 Mass per unit length M	4
4.8 Mass of the outer sheath material S_p	4
4.9 Mass of the core material C	4
4.10 Fall arrest peak force F	4
4.11 Dynamic performance	4
4.12 Static strength	4
5 Test methods	5
5.1 Samples	5
5.2 Conditioning	5
5.3 Rope diameter D	5
5.4 Knotability K	5
5.5 Sheath slippage S_s	6
5.6 Elongation E	8
5.7 Shrinkage R	8
5.8 Mass per unit length M , core material C and sheath material S_p	9
5.9 Dynamic tests	9
5.10 Static strength test of terminations	12
6 Marking	12
7 Information to be supplied by the manufacturer including instructions for use	13
Annex A (informative) Recommendations for inspection and care of low stretch kernmantel ropes in use	14
Annex ZA (informative) Clauses of this European Standard addressing essential requirements or other provisions of EU Directives	16

Introduction

Ropes for use in rope access, rescue and in speleology are used in similar ways and therefore require the same characteristics. They are used in combination with ascending, descending and safety devices for work positioning in rope access; lowering or raising casualties in rescue; as a means of ascent, descent and horizontal motion in speleology. The characteristics required are low extension during normal working procedure but with the capacity to withstand forces generated by a fall. Some energy absorption of these impact forces is also desirable, the amount usually a compromise with the acceptable extension during normal working practice.

1 Scope

This European Standard applies to low stretch textile ropes of kernmantel construction from 8,5 mm to 16 mm diameter, for use by persons in rope access including all kinds of work positioning and restraint; for rescue and in speleology. Two types of low stretch kernmantel rope are defined: A and B. The European Standard specifies requirements, testing, marking and information to be supplied by the manufacturer including instructions for use of such low stretch kernmantel ropes.

NOTE 1 It is possible that rope not conforming to this European Standard may also be suitable for the activities described above.

NOTE 2 Ropes used for protection during any free climbing activity in rope access, rescue or speleology should take account of other standards, e.g. EN 892. Dynamic mountaineering rope may also be used for protection during rope access and work positioning.

2 Normative references

This European Standard incorporates, by dated or undated reference, provisions from other publications. These normative references are cited at the appropriate places in the text and the publications are listed hereafter. For dated references, subsequent amendments to or revisions of any of these publications apply to this European Standard only when incorporated in it by amendment or revision. For undated references the latest edition of the publication referred to applies.

EN 364:1992, *Personal protective equipment against falls from a height — Test methods.*

EN 365:1992, *Personal protective equipment against falls from a height — General requirements for instructions for use and for marking.*

EN 701:1995, *Fibre ropes for general service — General specification.*

EN 919:1995, *Fibre ropes for general service — Determination of certain physical and mechanical properties.*

EN 892, *Mountaineering equipment — Dynamic mountaineering ropes — Safety requirements and test methods.*

3 Definitions

For the purposes of this European Standard the following definitions shall apply:

3.1

low stretch kernmantel rope

a textile rope consisting of a core enclosed by a sheath, designed for use by persons in rope access including all kinds of work positioning and restraint; for rescue and speleology

NOTE The core is usually the main load bearing element and typically consists of parallel elements which have been drawn and turned together in single or several layers, or of braided elements. The sheath is generally braided and protects the core, for example from external abrasion and ultraviolet degradation.

3.2

rope access

the technique of using ropes, in combination with other devices, for getting to and from the place of work and for work positioning

3.3

work positioning

a technique which enables a person to work supported in tension or suspension by personal protective equipment, in such a way that a fall is prevented

3.4

type A ropes

low stretch kernmantel ropes designed for general use by persons in rope access including all kinds of work positioning and restraint; in rescue and in speleology

3.5

type B ropes

low stretch kernmantel ropes of a lower performance than type A ropes, requiring greater care in use

4 Requirements

4.1 Materials

Materials used in the manufacture of low stretch kernmantel ropes shall be of continuous virgin synthetic fibre. The materials used for the construction of the sheath and the core shall be known to have a melting point > 195 °C.

4.2 Rope diameter *D*

When calculated as the arithmetic mean of the six measurements described in 5.3, the rope diameter *D* shall be a minimum of 8,5 mm and a maximum of 16 mm.

4.3 Knotability *K*

The rigidity of the low stretch kernmantel rope shall be such that the knotability *K* shall be less than 1,2 when determined in the knot test specified in 5.4.

4.4 Sheath slippage S_s

Sheath slippage S_s in a longitudinal direction relative to the core shall be determined as specified in 5.5. With the rope diameter D as specified in 5.3, the sheath slippage for type A ropes shall not exceed $20 \text{ mm} + 10 (D - 9 \text{ mm})$ for ropes up to 12 mm diameter, and $20 \text{ mm} + 5 (D - 12 \text{ mm})$ for ropes with a diameter between 12,1 mm and 16 mm. For type B ropes the sheath slippage shall not exceed 15 mm. Measurements shall be according to value V in 5.5.6 and shall be reported as a percentage as described in 5.5.6.

4.5 Elongation E

When tested as described in 5.6, the elongation E shall not exceed 5 %.

4.6 Shrinkage R

Shrinkage R shall be determined as described in 5.7.

4.7 Mass per unit length M

The mass per unit length M of 1000 mm of low stretch kernmantel rope shall be determined as described in 5.8.

4.8 Mass of the outer sheath material S_p

When tested as described in 5.8, the minimum mass of the material used in the sheath alone, as a percentage of the total mass of the low stretch kernmantel rope, shall be:

$$S_{\min} = \frac{\left(\frac{D}{2}\right)^2 - \left(\frac{D-2}{2}\right)^2}{\left(\frac{D}{2}\right)^2} \cdot 100 \text{ in percentage}$$

which can be simplified to:

$$S_{\min} = \frac{4D - 4}{D^2} \cdot 100 \text{ in percentage}$$

where S = sheath and D = rope diameter as measured in 5.3.

If the construction of the low stretch kernmantel rope is such that separating the sheath and the core is impracticable, an appropriate substitute method of determining the percentage mass of the outer sheath material may be used.

4.9 Mass of the core material C

When tested as described in 5.8, the minimum mass of the material used in the core alone, as a percentage of the total mass of the low stretch kernmantel rope, shall be:

for type A ropes:

$$C_{\min} = \frac{12}{\left(\frac{D}{2}\right)^2} \cdot 100 \text{ in percentage}$$

which can be simplified to:

$$C_{\min} = \frac{48}{D^2} \cdot 100 \text{ in percentage}$$

for type B ropes:

$$C_{\min} = \frac{10}{\left(\frac{D}{2}\right)^2} \cdot 100 \text{ in percentage}$$

which can be simplified to:

$$C_{\min} = \frac{40}{D^2} \cdot 100 \text{ in percentage}$$

where C = core and D = rope diameter as measured in 5.3.

If the construction of the low stretch kernmantel rope is such that separating the sheath and the core is impracticable, an appropriate substitute method of determining the percentage mass of the core material may be used.

4.10 Fall arrest peak force F

When tested as described in 5.9.4, the peak force shall not exceed 6 kN.

4.11 Dynamic performance

When tested as described in 5.9.5, the low stretch kernmantel rope shall withstand five falls without releasing the mass.

4.12 Static strength

4.12.1 Static strength without terminations

When tested according to the appropriate parts of 4.1, 5.1, 6, 8.1, 8.2, 8.5 and 9.5 of EN 919:1995, the low stretch kernmantel rope shall sustain a force of at least 22 kN for type A ropes and at least 18 kN for type B ropes.

4.12.2 Static strength with terminations

Terminations may be made with knots or by other methods. When tested as described in 5.10, the low stretch kernmantel rope including terminations shall sustain a force of $(15^{+0,5}_0)$ kN for type A ropes and $(12^{+0,5}_0)$ kN for type B ropes, each for a period of 3 min.

It shall be possible to create a termination (loop) suitable for use as an attachment point anywhere on the low stretch kernmantel rope, for example, a figure of eight knot.

5 Test methods

5.1 Samples

The number and length of rope samples to be tested are noted in each test clause. The samples shall correspond to low stretch kernmantel ropes to be marketed in every respect except for colour, for which there is no requirement.

5.2 Conditioning

All the rope samples shall be conditioned in an atmosphere of less than 10% humidity for at least 24 h. The rope samples shall then be stored at a temperature of $(20 \pm 2)^\circ\text{C}$ and a humidity of $(65 \pm 5)\%$ for at least 72 h.

Tests shall be carried out at a temperature of $(23 \pm 5)^\circ\text{C}$.

5.3 Rope diameter D

5.3.1 Sample

One unused rope sample having a minimum length of 3 000 mm shall be used for the test.

5.3.2 Procedure

5.3.2.1 Attach one end of the rope sample to a suitable fixture.

5.3.2.2 Apply a load without shock in the form of a mass of $(10 \pm 0,1)$ kg, or a corresponding force, at a distance of at least 1 300 mm from the attachment point.

5.3.2.3 Continue application of the load described in **5.3.2.2** for (60 ± 15) s. After this loading period, with the load still applied, measure the low stretch kernmantel rope in two directions around the diameter, starting at points 90° apart, at each of three levels approximately 300 mm apart. The contact length of the measuring instrument shall be (50 ± 1) mm. The low stretch kernmantel rope cross-sectional area shall not be subject to any deformation during measurement.

5.3.3 Expression of results

Express the diameter D as the arithmetic mean of the six measurements to the nearest 0,1 mm. Confirm that the arithmetic mean of the six measurements is not less than 8,5 mm or greater than 16 mm.

5.4 Knotability K

5.4.1 Sample

One unused rope sample having a minimum length of 3 000 mm shall be used for the test.

5.4.2 Procedure

5.4.2.1 Make two single overhand knots in the rope sample (250 ± 50) mm apart with the knot loops running in opposite directions.

5.4.2.2 Attach one end of the rope sample to a suitable fixture.

5.4.2.3 Apply a load without shock in the form of a mass of $(10 \pm 0,1)$ kg, or a corresponding force, so that the load affects both knots.

5.4.2.4 Continue application of the load described in **5.4.2.3** for (60 ± 15) s.

5.4.2.5 Reduce the load to $(1 \pm 0,1)$ kg and then, while still under this load, measure the internal diameter of the knots to the nearest 0,5 mm using a suitable measuring device such as a tapered plug gauge (see Figure 1), without allowing an alteration of the free width of the knot by the pressure of the measuring device (see Figure 2).

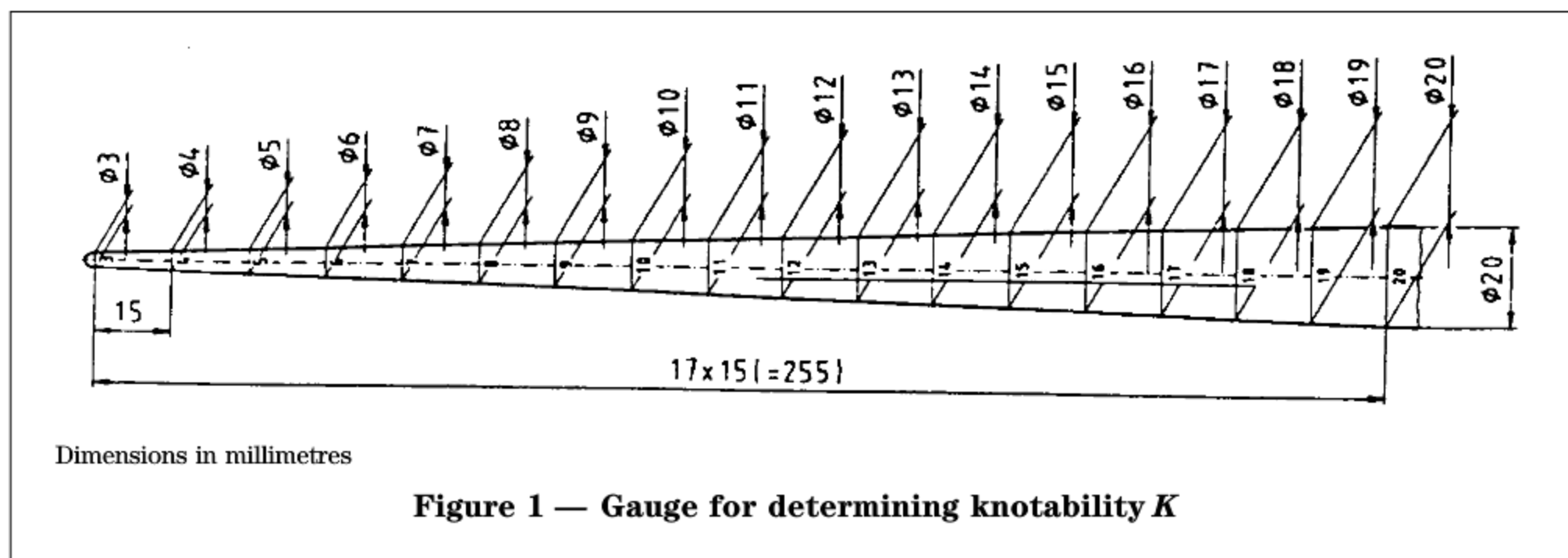

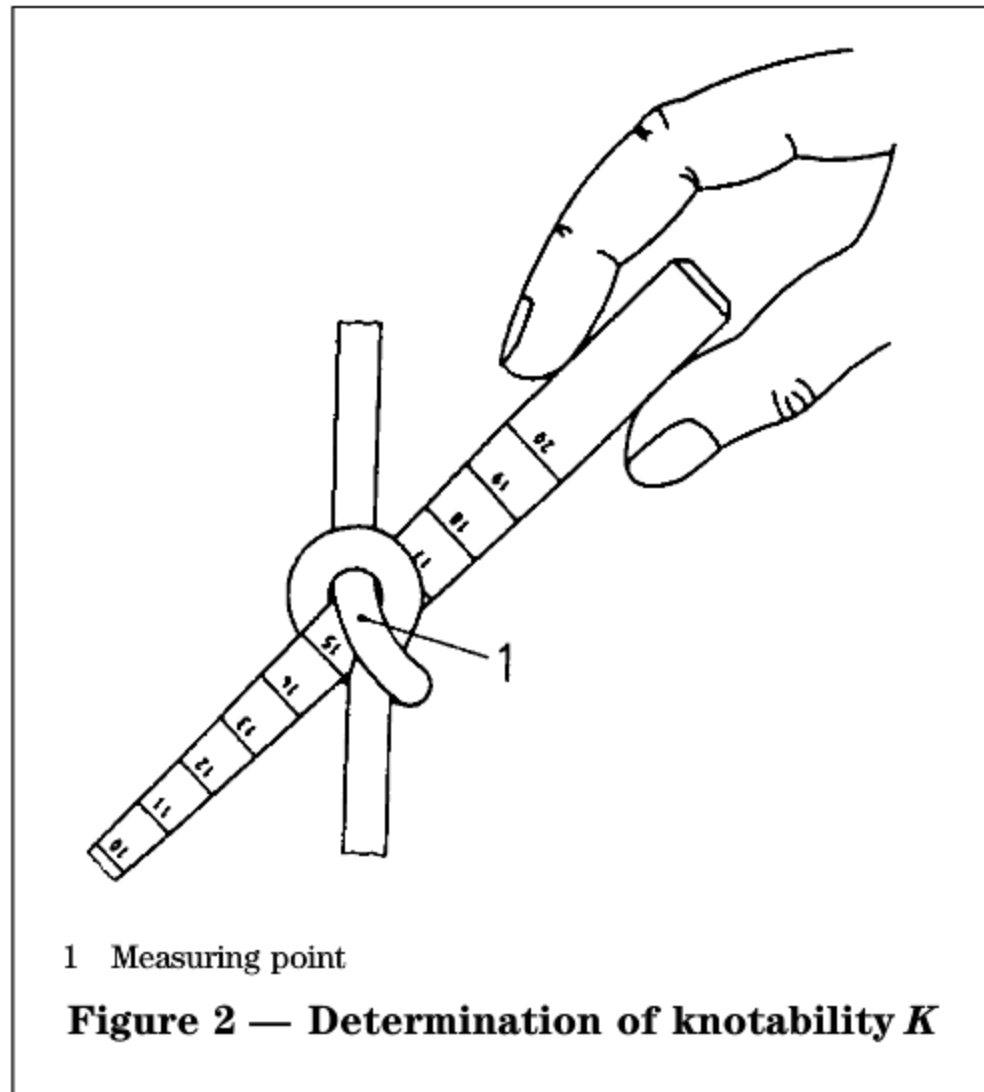

5.4.3 Expression of results

5.4.3.1 Calculate the average of the internal diameters of both knots.

5.4.3.2 Knotability shall thus be calculated from:

$$K = \frac{\text{average internal diameter of the knots}}{\text{rope diameter as specified in 5.3.3}}$$

5.5 Sheath slippage S_S

5.5.1 General information

In order to determine sheath slippage, the low stretch kernmantel rope shall be drawn through the apparatus illustrated in Figure 3, where the movement is restricted by radial forces. The resulting frictional force on the sheath causes slippage of the sheath relative to the core. The extent of this slippage shall be measured.

5.5.2 Sample

One unused rope sample with a length of $(2\,250 \pm 10)$ mm shall be used for the test.

5.5.3 Preparation

One end of the sheath and core of the rope sample shall be fused (heat sealed) together. The other end shall be cut at right angles to the axis of the low stretch kernmantel rope.

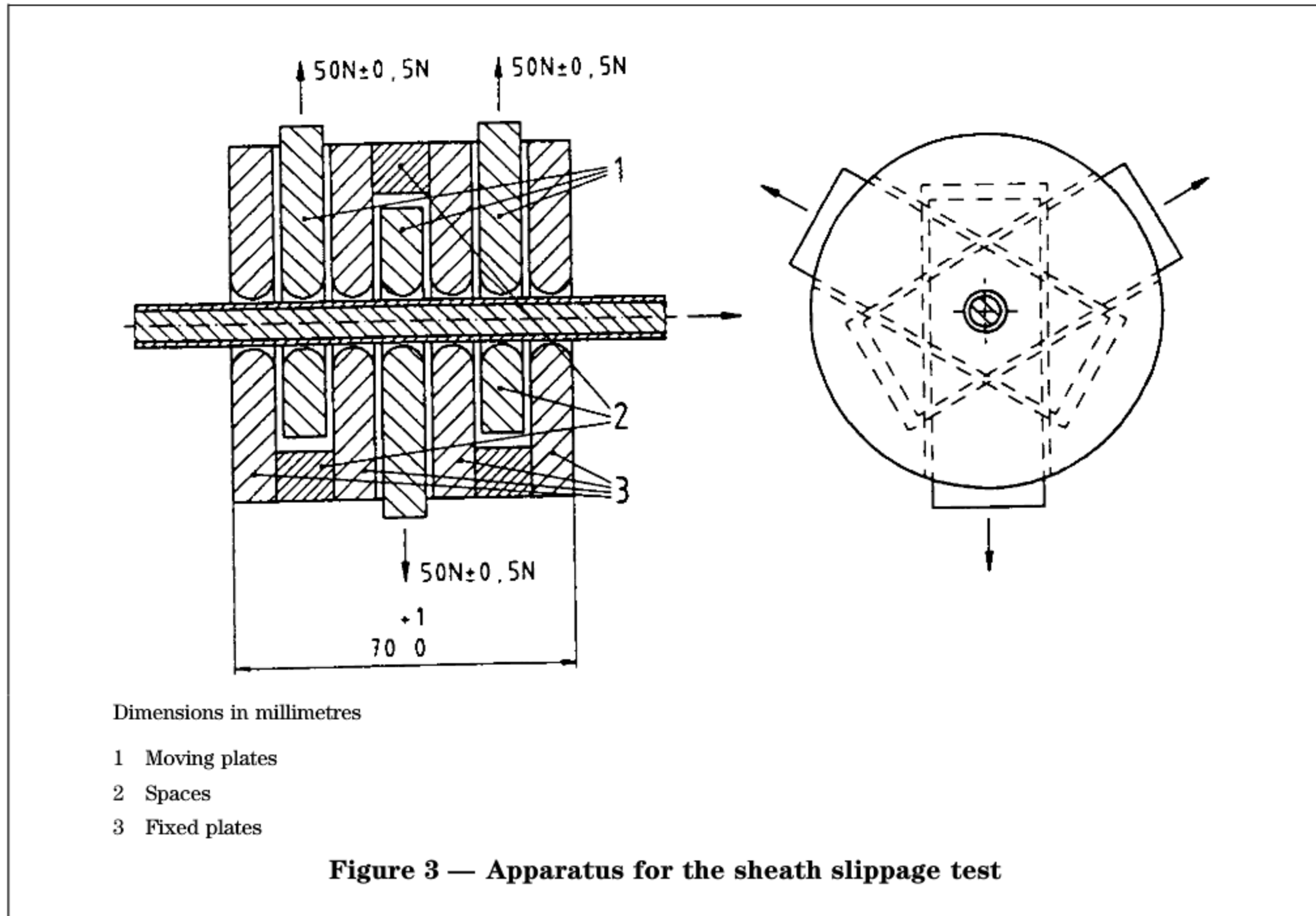

5.5.4 Apparatus

5.5.4.1 The apparatus shall consist of a frame made out of four steel plates each 10 mm thick, kept equal distances apart by three spacers. These spacers shall have rectangular slots in which the 10 mm thick steel plates are able to slide in a radial direction. The spacers shall be arranged in such a way as to allow each of the three inserted plates to slide at an angle of 120° (see Figure 3).

5.5.4.2 Each of the seven plates shall have an opening with a diameter of (12^{+1}_0) mm when testing ropes up to 12 mm diameter as specified in 5.3, and with a diameter of (16^{+1}_0) mm when testing ropes with a diameter of between 12,1 mm and 16 mm as specified in 5.3. The internal surfaces shall be semi-toroidal and have a radius of 5 mm. The polished surfaces of the semi-torus shall show a mean roughness value of a maximum of $R_a = 0,4 \mu\text{m}$ and a maximum peak-to-valley value of $R_{\text{max}} = 4 \mu\text{m}$ (see Figure 4).

5.5.4.3 In the unloaded position, the openings in the fixed plates and in the moving plates shall lie along a central axis. Each of the moving plates shall apply a radial force of $(50 \pm 0,5)$ N in the direction in which it moves.

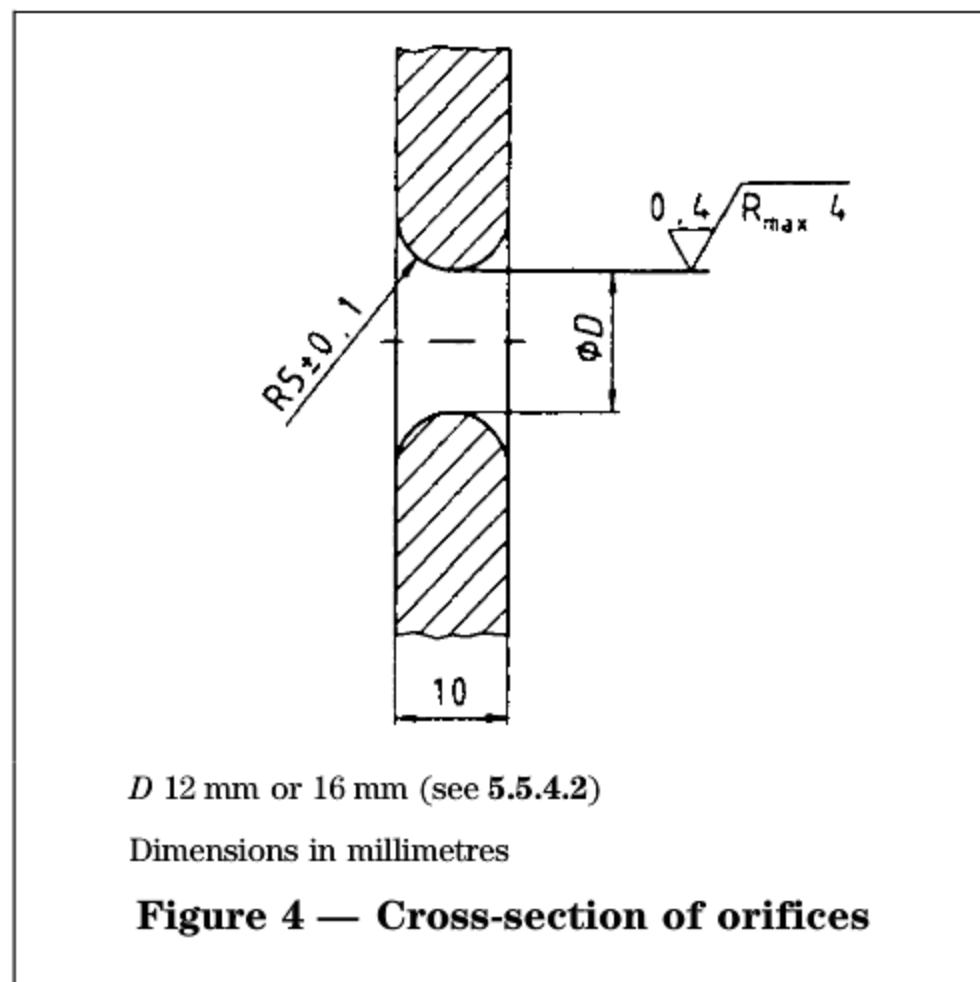

5.5.5 Procedure

5.5.5.1 At the start of the test, the openings of the moving plates and of the fixed plates shall be coaxial.

5.5.5.2 Introduce the fused end of the rope sample into the apparatus and pull to a length of (200 ± 10) mm through the test apparatus (see Figure 5). Ensure that the open end of the rope sample is not subjected to any load and lies in a horizontal position in a straight line.

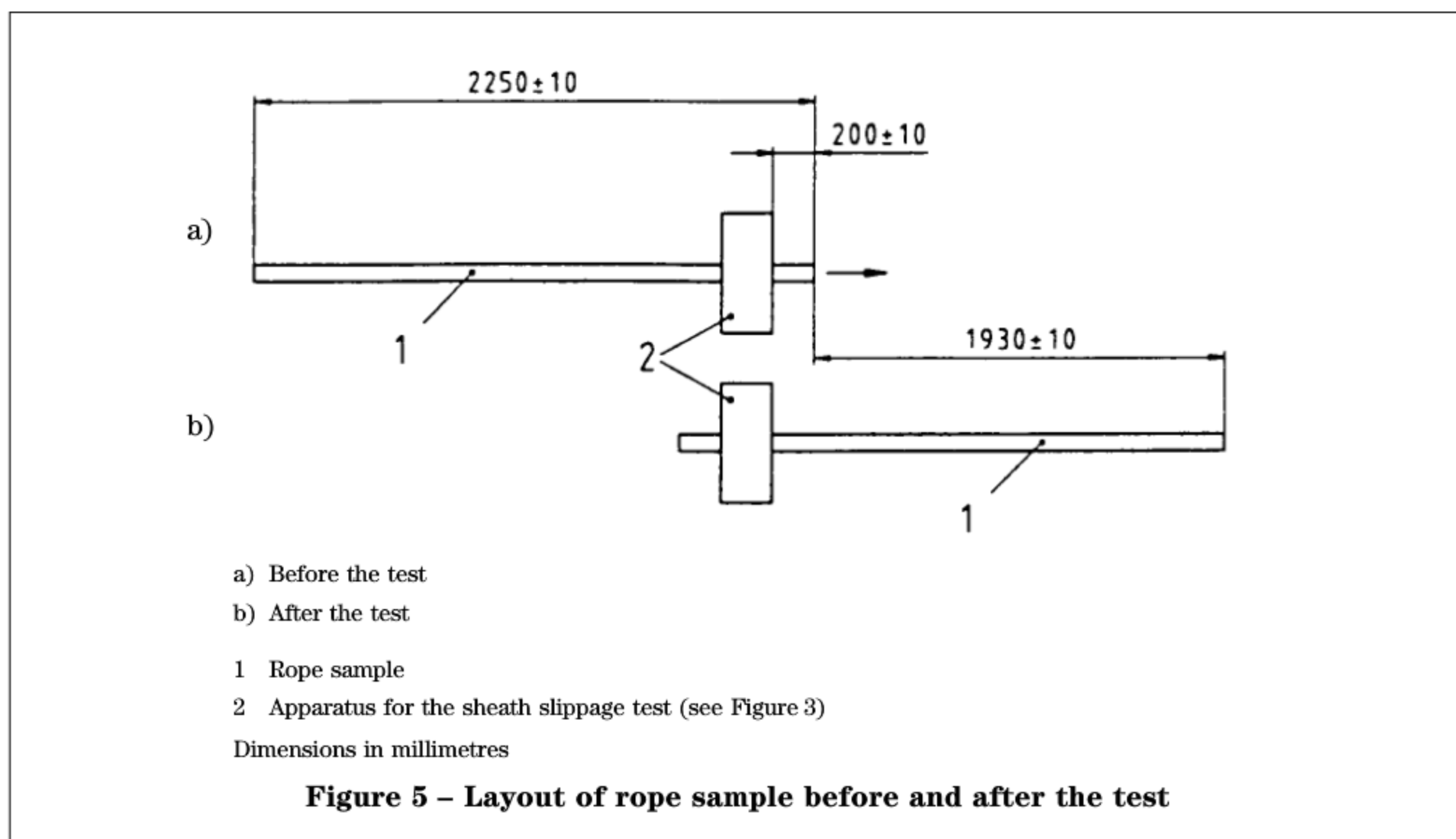

5.5.5.3 Then apply a force of $(50 \pm 0,5)$ N to the low stretch kernmantel rope via each of the three moving plates and pull the rope sample through the apparatus at a rate of $(0,5 \pm 0,2)$ m/s for a distance of $(1\,930 \pm 10)$ mm.

5.5.5.4 Remove the loads from the sliding plates, push them back to their original coaxial position and bring the rope sample to its initial position.

5.5.5.5 Repeat the test described above four times. After the last test remove the rope sample completely from the test apparatus.

5.5.6 Expression of results

After the fifth test measure the relative slippage of the sheath along the core at the free end of the rope sample (see Figure 6). Measure and express the value V to the nearest millimetre. Use this value V to calculate the percentage slippage S_s .

$$S_s = \frac{V \cdot 100}{1\,930} \text{ to the nearest } 0,1 \text{ in percentage}$$

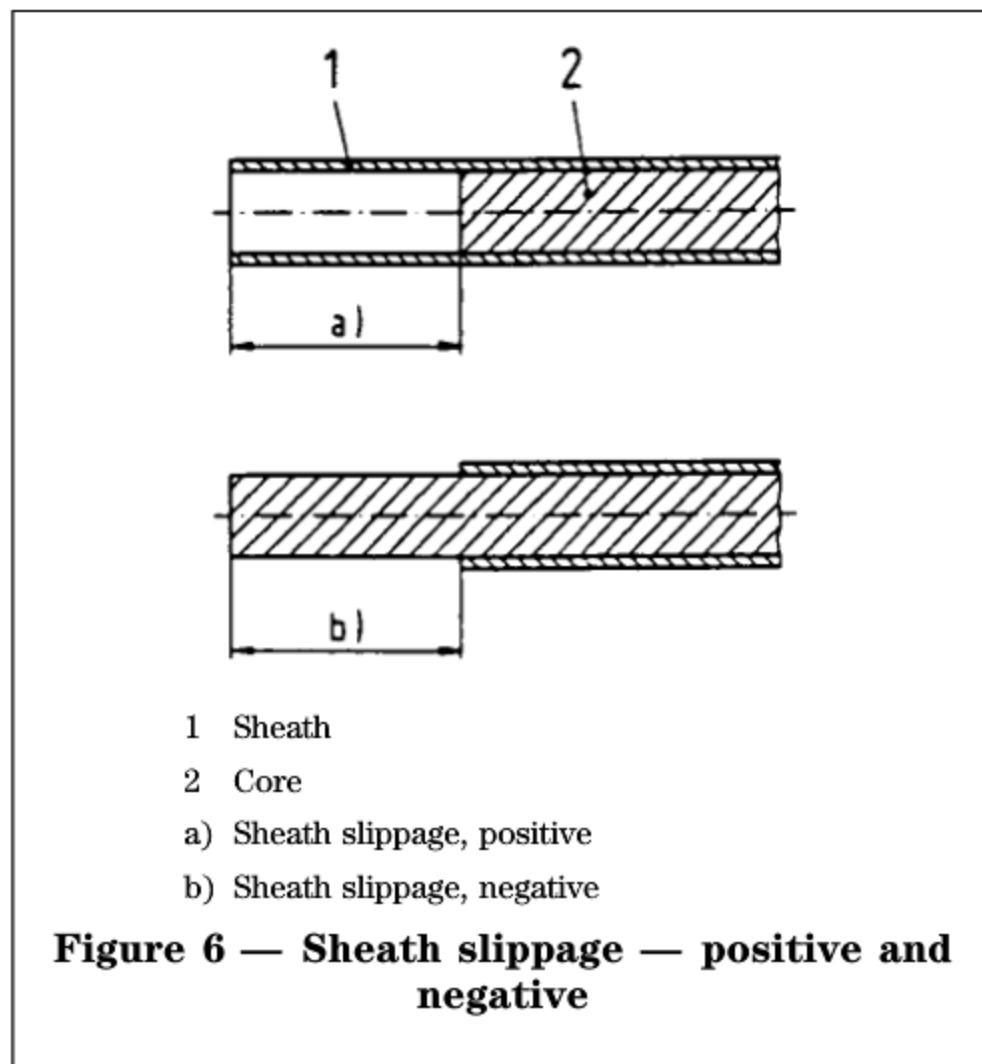

Figure 6 — Sheath slippage — positive and negative

5.6 Elongation E

5.6.1 Sample

One unused rope sample having a minimum length of 3 000 mm shall be used for the test.

5.6.2 Procedure

5.6.2.1 Attach one end of the rope sample to a suitable fixture.

5.6.2.2 Apply a load without shock in the form of a mass of $(50 \pm 0,1)$ kg, or a corresponding force, to the rope sample.

5.6.2.3 Continue application of the load described in **5.6.2.2** for $(5 \pm 0,5)$ min then, with the load still applied, make two marks on the rope sample $(1\,000 \pm 1)$ mm apart. Let this distance be L_A .

5.6.2.4 Apply an increase in mass without shock of $(100 \pm 0,1)$ kg, or a corresponding force, to give a total load on the rope sample of $(150 \pm 0,2)$ kg.

5.6.2.5 Apply the load described in **5.6.2.4** for $(5 \pm 0,5)$ min then, with the load still applied, measure the new distance L_B between the two markings on the stressed rope sample. Express this distance L_B to the nearest millimetre.

5.6.3 Expression of results

Express the elongation as a percentage (to the nearest 0,1 %) of $L_B - L_A$ divided by L_A .

$$E = \frac{(L_B - L_A)100}{L_A}$$

5.7 Shrinkage R

5.7.1 Sample

One unused rope sample having a minimum length of 3 000 mm shall be used for the test.

5.7.2 Procedure

5.7.2.1 Attach one end of the rope sample to a suitable fixture.

5.7.2.2 Apply a load without shock in the form of a mass of $(10 \pm 0,1)$ kg, or a corresponding force, at least 1 300 mm from the clamp or inner end of any formed termination (e.g. figure of eight knot).

5.7.2.3 Continue application of the load described in **5.7.2.2** for (60 ± 15) s then, with the load still applied, make two marks on the rope sample $(1\,000 \pm 1)$ mm apart at least 100 mm away from the clamp or inner end of any formed termination. Let this distance be L_A .

5.7.2.4 Release the load.

5.7.2.5 After first ensuring that the ends of the rope sample are fused (heat sealed), submerge it in clean water within a temperature range of (15 ± 5) °C and a pH range of 5.5 to 8 for a period of $(24 \pm 0,2)$ h.

5.7.2.6 Within 15 min of removal from the water, reapply the load as described in **5.7.2.1** and **5.7.2.2**

5.7.2.7 Continue application of the load described in **5.7.2.6** for (60 ± 15) s then, with the load still applied, measure the distance between the two marks described in **5.7.2.3**. Express this distance L_B to the nearest millimetre.

5.7.3 Expression of results

Express the shrinkage as a percentage (to the nearest 0,1 %) of $L_A - L_B$ divided by L_A .

$$R = \frac{(L_A - L_B)100}{L_A}$$

5.8 Mass per unit length M , core material C and sheath material S_p

5.8.1 Sample

One unused rope sample having a minimum length of 3 000 mm shall be used for the test.

5.8.2 Procedure

5.8.2.1 Attach one end of the rope sample to a suitable fixture.

5.8.2.2 Apply a load without shock in the form of a mass of $(10 \pm 0,1)$ kg, or a corresponding force, at least 1 300 mm from the clamp or inner end of any formed termination (e.g. figure of eight knot).

5.8.2.3 Continue application of the load described in **5.8.2.2** for (60 ± 15) s then, with the load still applied, make two marks on the rope sample $(1\ 000 \pm 1)$ mm apart at least 100 mm away from the clamp or inner end of any formed termination.

5.8.2.4 Release the load, cut out the marked portion of the low stretch kernmantel rope and determine the mass to the nearest 0,1 g.

5.8.2.5 Separate the sheath from the core of the sample and determine the mass of the sheath to the nearest 0,1 g.

5.8.3 Expression of results

5.8.3.1 Calculate the mass of the sheath S_p as a percentage of the total mass of the core and the sheath. Express as S_p to the nearest whole number.

5.8.3.2 Calculate the mass of the core C as a percentage of the total mass of the core and the sheath. Express as C to the nearest whole number.

5.8.3.3 Express the mass of the sheath and core combined as M in g/m to the nearest whole number.

5.9 Dynamic tests

5.9.1 General

There are two types of dynamic test which use the same test specimen.

5.9.2 Apparatus

5.9.2.1 The dynamic performance test apparatus shall comply with **4.1.1** paragraph 2; **4.4** and **4.6** of EN 364:1992.

5.9.2.2 The falling mass shall be made of metal. Its shape is not specified; however, it shall be such that the distance between the point of attachment of the rope on the rigid structure and the point of attachment on the falling mass is 100 mm maximum.

5.9.2.3 The falling mass may be guided. If the falling mass is guided, its speed measured over a section of $(100 \pm 0,1)$ mm in the range from 4,95 m to 5,05 m beneath the release point, shall be $(9,9_{-0,2}^0)$ m/s.

NOTE This test of the apparatus controls the amount of friction allowed in a guiding device.

5.9.2.4 The entire falling mass, including fixing bracket and possibly also a measuring device, shall weigh (100 ± 1) kg for type A ropes and (80 ± 1) kg for type B ropes.

5.9.3 Sample

5.9.3.1 If the low stretch kernmantel rope is to be placed on the market without preformed termination loops, one unused rope sample of 4 000 mm minimum length shall be used for the tests, otherwise one unused sample of the same length shall be supplied with each type of preformed termination.

5.9.3.2 Samples provided without preformed terminations shall be terminated at both ends in loops produced by tying figure of eight knots, as shown in Figure 7c), unless supplied as described in **5.9.3.3**.

5.9.3.3 If the low stretch kernmantel rope is placed on the market with preformed termination loops, one end of the sample shall be terminated in the form of a loop produced by tying a figure of eight knot, as shown in Figure 7c), and the other end terminated as supplied.

5.9.3.4 The length of the termination loops described in **5.9.3.2** and **5.9.3.3** from the inner end of the termination (including the knot or any other fastening arrangement except splicing) to the outer edge of the loop shall be (175 ± 25) mm while under a load of (100 ± 1) kg for type A ropes and (80 ± 1) kg for type B ropes (see Figure 7a). Visually check that the knots on the termination loops are symmetrical and that the ropes lie parallel in the knot, and hand tighten equally as shown in Figure 7c).

5.9.3.5 The length of the sample when suspended by the 100 kg mass for type A ropes or the 80 kg mass for type B ropes shall be $(2\ 000_{+100}^0)$ mm when measured between the attachment points of the rigid structure and the suspended mass.

5.9.4 Fall arrest peak force test F

5.9.4.1 Carry out the first test on the sample prepared as described in **5.9.3** within 10 min of the low stretch kernmantel rope's removal from the standard atmosphere (see **5.2**).

5.9.4.2 Suspend the 100 kg mass for type A ropes or the 80 kg mass for type B ropes from the rigid structural anchorage point, by connecting the sample between them, for (60_{+10}^0) s.

5.9.4.3 Raise the mass by (600_{+20}^0) mm at a maximum of 100 mm horizontally from the rigid structural anchorage point. Hold it by the quick release device (see Figure 8).

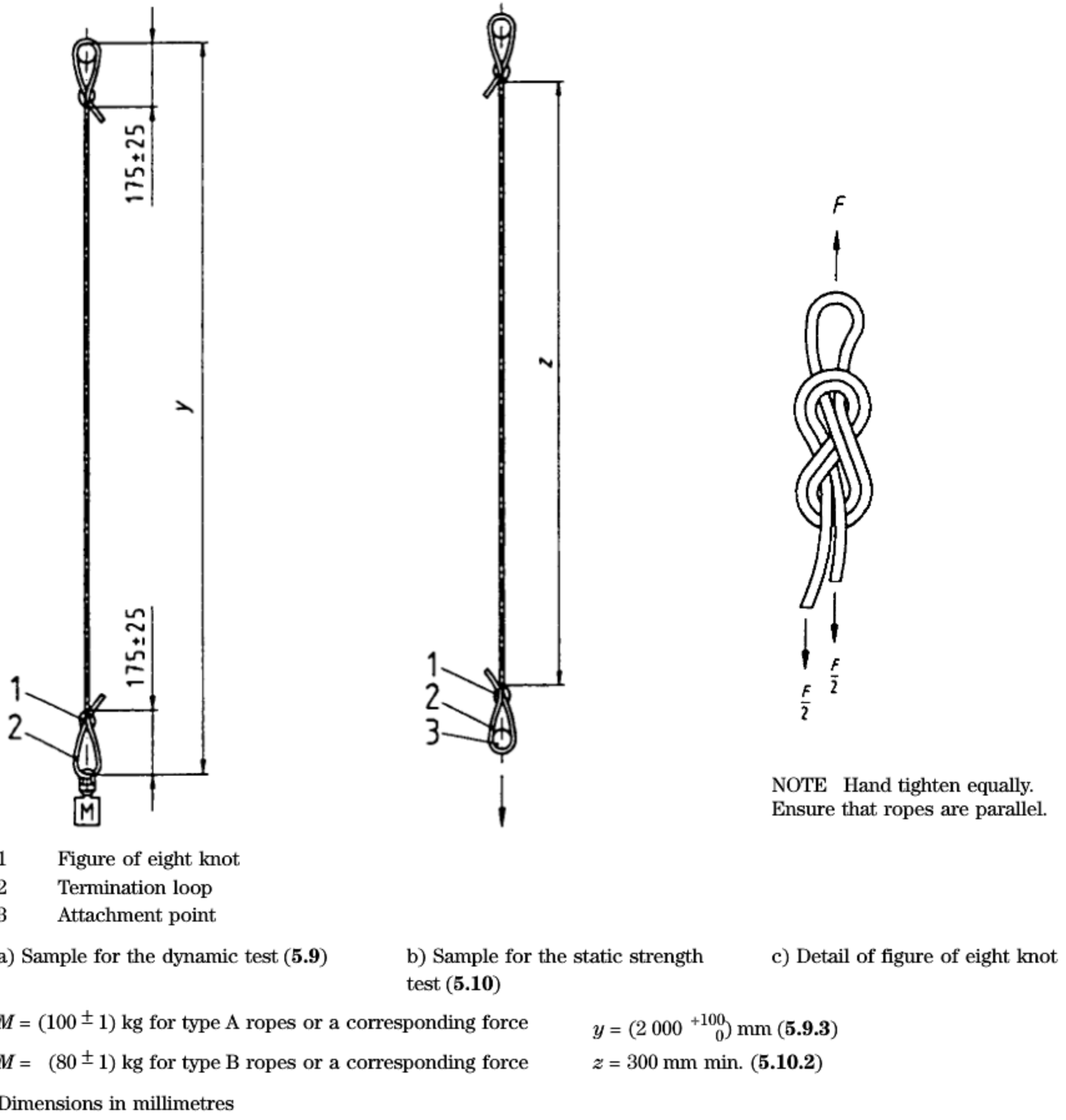
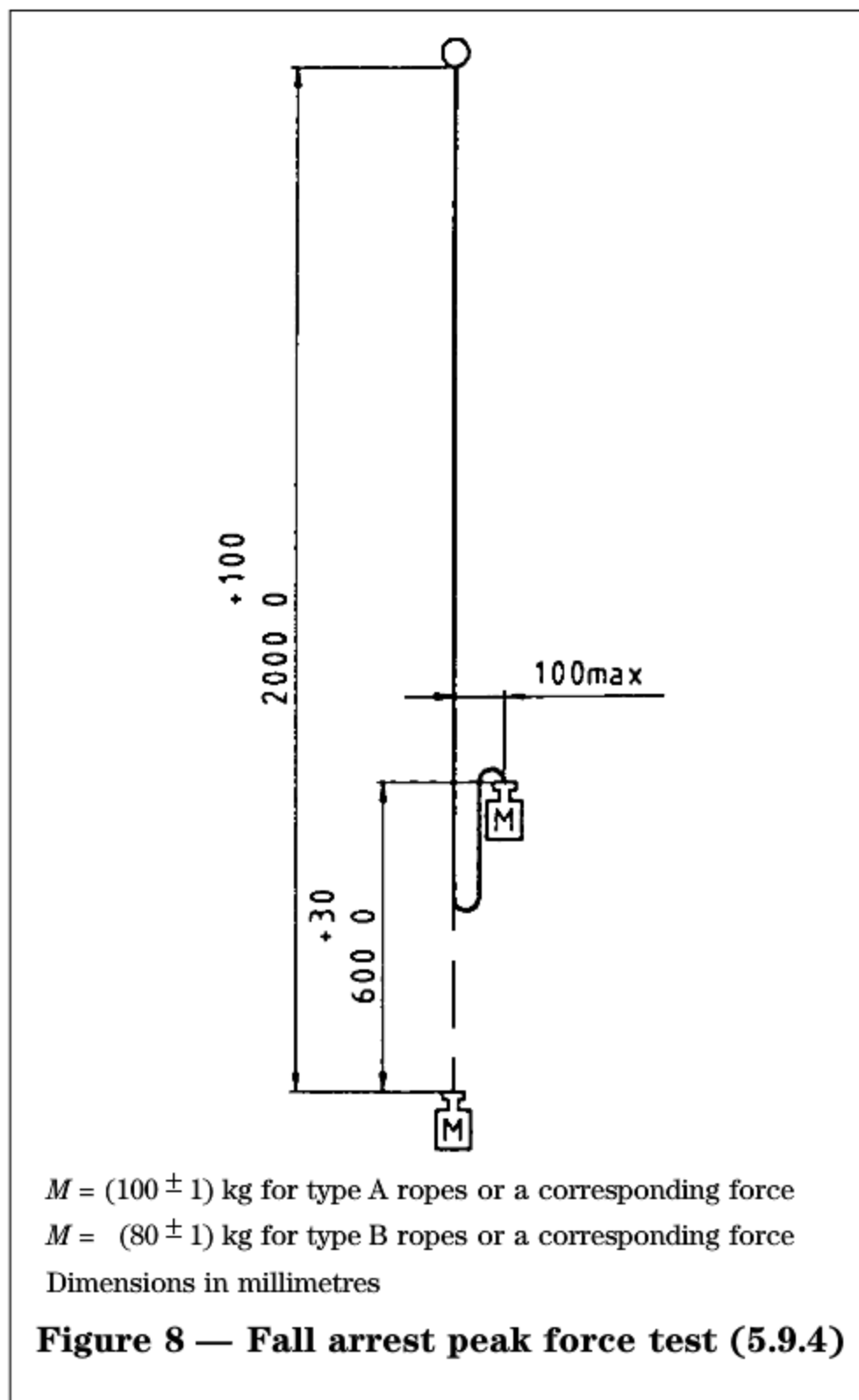

Figure 7 — Preparation of the sample



5.9.4.4 Activate the quick release device and allow the mass to fall.

5.9.4.5 Measure and record the peak force. Express the result to the nearest 0,1 kN.

5.9.4.6 Release the load from the sample within 1 min. Do not remove the sample from the test rig. Proceed with the sample as specified in 5.9.5.1. Carry out the first dynamic performance test in accordance with 5.9.5.2 within $(3 \pm 0,5)$ min of releasing the load from the sample.

5.9.5 Dynamic performance test

5.9.5.1 Raise the 100 kg mass for type A ropes or the 80 kg mass for type B ropes so that the attachment point of the mass is at the same height as the anchorage point on the rigid structure, at a maximum of 100 mm horizontally from it (see Figure 9). Hold the mass by the quick release device.

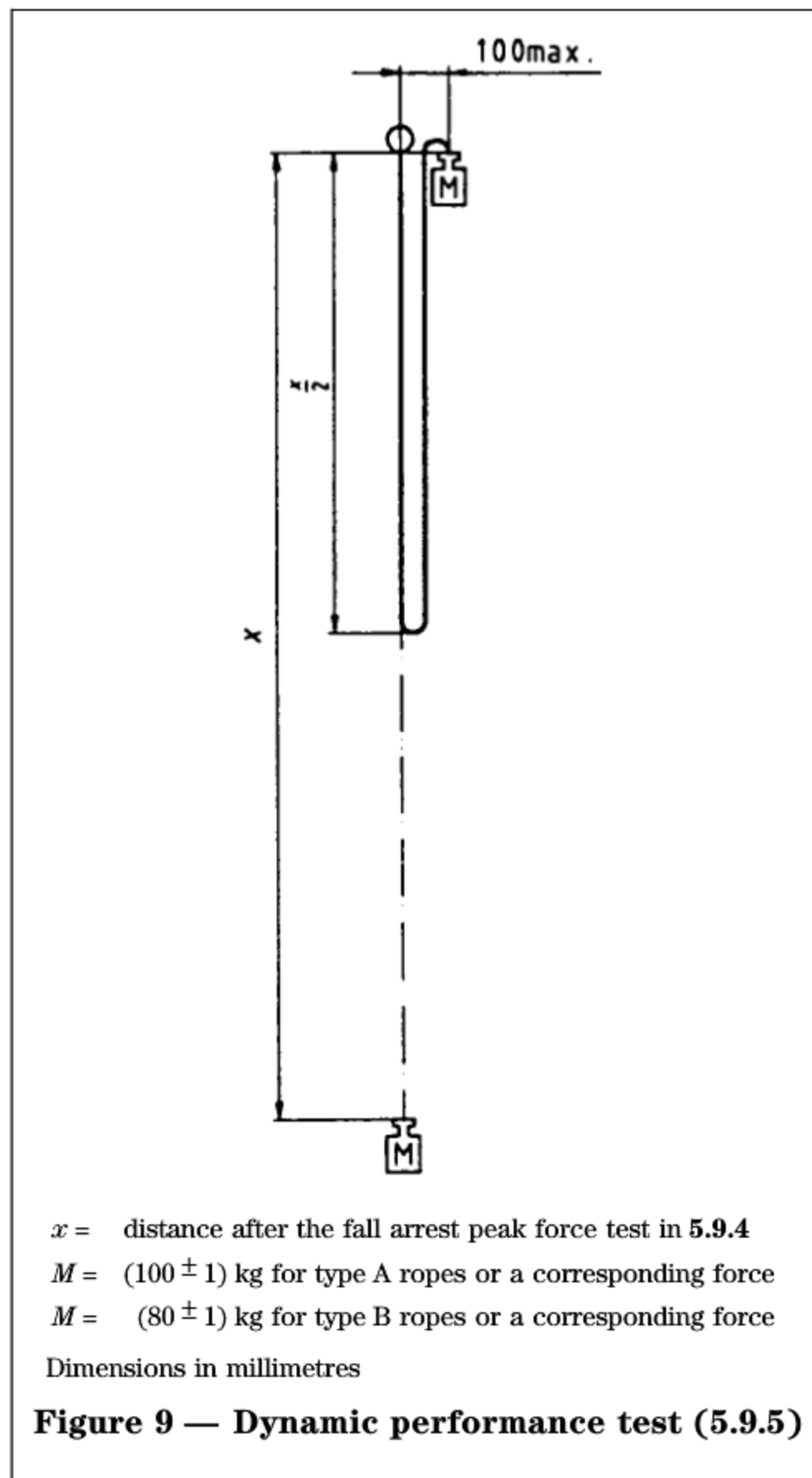

5.9.5.2 Activate the quick release device and allow the mass to fall.

5.9.5.3 After the drop release the load from the low stretch kernmantel rope within 1 min.

5.9.5.4 The interval between the consecutive tests on the rope sample shall be $(3 \pm 0,5)$ min from release to release.

5.9.5.5 Carry out the tests specified in 5.9.5 on the rope sample five times or until the low stretch kernmantel rope releases the mass.

5.10 Static strength test of terminations

5.10.1 Apparatus

5.10.1.1 Force measurement requirements

Force measuring requirement shall be in accordance with 4.1.1 of EN 364:1992.

5.10.1.2 Requirements for rate of stressing

Requirements for the rate of stressing shall be in accordance with 4.1.2.2 of EN 364:1992.

5.10.1.3 Attachment points

Each rigid anchorage point should be a ring of (20 ± 1) mm bore and (15 ± 1) mm diameter cross-section, or a rod of the same diameter cross-section.

5.10.2 Sample

5.10.2.1 One unused rope sample of 3 000 mm minimum length shall be used for the test.

5.10.2.2 The sample shall be terminated at both ends in loops produced by tying figure of eight knots, unless supplied as described in 5.10.2.3.

5.10.2.3 If the low stretch kernmantel rope is supplied with termination loops formed differently from those described in 5.10.2.2, one end of the sample shall be terminated in the form of a loop produced by tying a figure of eight knot.

5.10.2.4 The minimum rope length between the attachment points of the test machine, excluding terminations, shall be 300 mm before any load is applied [see Figure 7b)]. Visually check that the knots on the termination loops are symmetrical and that the ropes lie parallel in the knot, and hand tighten equally as shown in Figure 7c).

5.10.3 Procedure

5.10.3.1 Install the sample, prepared as described in 5.10.2, in the test machine.

5.10.3.2 Submit the sample to the specified force (see 4.12.2).

5.10.3.3 Observe that the sample withstands the force for a period of 3 min.

6 Marking

6.1 Marking on the low stretch kernmantel rope shall comply with 2.2 of EN 365:1992 and at least with 6.2 and 6.3.

6.2 Low stretch kernmantel rope shall have external bands at both ends which shall have the following permanent markings:

a) the letter A for type A ropes or the letter B for type B ropes followed by the diameter in millimetres as specified in 4.2 e.g. A11,0; B9,2.

b) the number of this European Standard.

6.3 Low stretch kernmantel rope shall have the following internal markings repeated at least every 1 000 mm throughout its length:

a) the name or trade mark of the manufacturer, importer or supplier;

b) the number of this European Standard and the type of rope, A or B;

c) the year of manufacture;

d) either the name of the material(s) from which the low stretch kernmantel rope is made, or a colour to signify the material from which the low stretch kernmantel rope is made according to EN 701.

NOTE The material used to carry the marks described in 6.3 need not be the same as that used for the construction of the low stretch kernmantel rope.

7 Information to be supplied by the manufacturer including instructions for use

The manufacturer's notes shall comply with 2.1 of EN 365:1992 and in addition shall include at least advice or information as follows:

- a) the name (model designation) if applicable and type (A or B) of the low stretch kernmantel rope;
- b) the diameter D of the rope as specified in 4.2;
- c) the sheath slippage S_S as specified in 4.4;
- d) the elongation I as specified in 4.5;
- e) the mass of the outer sheath S_P as specified in 4.8;
- f) the mass of the core material C as specified in 4.9;
- g) the mass per unit length M as specified in 4.7;
- h) the shrinkage R as specified in 4.6;
- i) the static strengths as specified in 4.12.1 and 4.12.2;
- j) the material(s) from which the low stretch kernmantel rope is made;
- k) the number of this European Standard: EN 1891;
- l) that, if type B ropes are chosen, users should be aware that the level of performance will be less than that of type A; that greater care will be required in protecting against the effects of abrasion, cuts, general wear and tear etc., and that in use great care should be taken to minimize the possibility of a fall. This advice shall be presented in such a way that it attracts the reader's attention, e.g. by the use of bold text or colour;
- m) that type A ropes are more suitable for use in rope access and work positioning than type B ropes;
- n) that the product should be used only by trained and/or otherwise competent persons or the user should be under the direct supervision of such a person;
- o) that before and during use, consideration should be given as to how any rescue could be safely and efficiently carried out;

p) on how to ensure the compatibility of any components to be used in conjunction with the low stretch kernmantel rope, e.g.

- that the adjustment device chosen is suitable for the diameter of the rope,
- by reference to other European Standards;

q) on limitations of the materials in the product or hazards which may affect its performance, e.g. temperature, the effect of sharp edges, chemical reagents, cutting, abrasion, knotting, UV degradation;

r) on disinfection of the product without adverse effect;

s) on the expected lifespan of the product (obsolescence) or how the user can determine the lifespan;

t) on how to protect the product during transportation;

u) on the meaning of any markings on the product (e.g. A10,5 means low stretch kernmantel rope type A and the number following is the diameter in millimetres when tested according to this European Standard);

v) on recommended methods of forming terminations on the low stretch kernmantel rope;

w) that the system should incorporate a reliable anchorage point, above the user, and that any slack low stretch kernmantel rope between the user and the reliable anchorage point should be avoided;

x) advice that for ropes used for protection during any free climbing activity in rope access, rescue or speleology, other European Standards shall be taken into account, e.g. EN 892 *Dynamic mountaineering ropes*;

y) advice that cut lengths of low stretch kernmantel rope should be marked as described in clause 6.

Annex A (informative)

Recommendations for inspection and care of low stretch kernmantel ropes in use

A.1 General

The recommendations in this annex are written with polyamide and polyester in mind, as these are the materials from which low stretch kernmantel ropes are usually made. However, unless polyamide or polyester are referred to specifically, the recommendations apply to low stretch kernmantel ropes made from any permitted material.

Ropes made from any material are liable to wear and to mechanical damage, and can be weakened to some extent by various agencies such as chemicals, heat and light. Regular inspection is therefore essential to ensure that the ropes are still serviceable.

It is also emphasized that, no matter what agency has weakened the rope, the effect will be more serious on the small sizes than on the larger sizes of rope. Consideration should be given, therefore, to the relationship of the surface area of the rope and the rope cross-section.

Examinations of about 300 mm at a time may prove to be convenient, the rope being turned to reveal all sides before continuing. At the same intervals, the strands should be untwisted slightly to allow examination between the strands.

To define a standard of acceptance or rejection is much more difficult than to describe the method of inspection. There can be no well defined boundary between ropes which are safe and those which are not because this depends on the stresses placed on a rope in an emergency. In practice, the decision whether to continue to use a rope or discard it should be based on an assessment of the general condition of the rope. Many of the conditions which will guide the examiner cannot be exactly described but can only be stated in general terms.

If, after examination, there is any doubt about the safety of the rope, it should be withdrawn from service. It is again emphasized that the effects of wear and mechanical damage are relatively greater on thinner ropes which, therefore, require more stringent standards of acceptance.

A.2 Physical causes of damage

A.2.1 General external wear

External wear due to dragging over rough surfaces causes surface chafing or filamentation. This is the most readily noticeable cause of weakness, particularly if a new rope is available for comparison. In the extreme, the strands become so worn that their outer faces are flattened and the outer yarns are severed. In ordinary use, some disarrangement or breakage of the fibres on the outside of the rope is unavoidable and harmless if not extensive. Polyamide and polyester filament ropes have a very good abrasion resistance.

A.2.2 Local abrasion

Local abrasion, as distinct from general wear, may be caused by the passage of the rope over sharp edges while under tension and may cause serious loss of strength.

Slight damage to the outer fibres and an occasional torn yarn may be considered harmless, but serious reduction in the cross-sectional area of one strand or somewhat less serious damage to more than one strand should merit rejection. Protection at points where excessive abrasion may occur is economic.

A.2.3 Cuts, contusions, etc.

Cuts, contusions, etc. or careless use may cause internal as well as external damage. This may be indicated by local rupturing or loosening of the yarns or strands.

A.2.4 Internal wear

Internal wear caused by repeated flexing of the rope, particularly when wet, and by particles of grit which have been picked up, may be indicated by excessive looseness of the strands and yarns or the presence of powdered fibre.

A.2.5 Repeated loading

The resistance of polyamide filament rope to damage due to repeated loading is good, but a permanent elongation may occur so that the extension available in an emergency is reduced.

If the original length of the rope is known exactly, a check measurement made under exactly the same conditions will indicate the total extension of the rope but may not reveal local extension of parts of the rope. Measurement of the distance between regularly spaced indelible markers on the rope may help to reveal severe local permanent elongation which may cause breakdown on subsequent loading.

A.3 External causes of damage

A.3.1 Mildew

Mildew does not attack polyamide or polyester ropes.

A.3.2 Heat

Heat may, in extreme cases, cause fusing. Any signs of this should obviously merit rejection, but a rope may be damaged by heat without any such obvious warning. The best safeguard is proper care in use and storage. A rope should never be dried in front of a fire or stored near a stove or other source of heat.

A.3.3 Strong sunlight

Strong sunlight causes weakening of rope fibres, but is unlikely to penetrate beneath the surface. Unnecessary exposure should be avoided.

Solar degradation should be checked by rubbing the surface of the rope with the thumb nail. If degradation has taken place, the surface material will come off as powder. In addition, the surface of the rope will feel dry, harsh and resinous.

Whilst the consequences of such degradation may be significant in small ropes, e.g. less than 20 mm, it is unlikely to be of significance in larger ropes during their expected period of life.

A.4 Chemical causes of damage

A.4.1 General

The variety of possible chemical contaminants of rope is very wide and the information given in **A.4.2** and **A.4.3** is only a general guide. In cases of uncertainty on the nature of the contaminant and the remedy to be adopted, an expert should be consulted. Attack may be more severe if some drying out occurs.

A.4.2 Polyamide ropes

Chemical attack of a sufficient degree may be indicated by local weakening or softening of the rope so that surface fibres can be plucked or rubbed off as a powder in extreme cases. The chemical resistance of polyamide filament is, in general, extremely good, but solutions of mineral acids cause rapid weakening. It is advisable, therefore, to avoid immersion in acid solutions, either cold or hot.

Polyamide filament is unaffected by alkalis at normal temperature and by many oils although it swells in contact with certain organic solvents. Exposure to fumes, spray or mist of acids or to organic solvents should be avoided, but, if contamination is suspected, the rope should be washed out well in cold water. If there is any doubt after subsequent careful inspection, the rope should be discarded.

Polyamide ropes absorb a limited amount of water when wetted and may lose a small proportion of their strength while wet.

A.4.3 Polyester ropes

Chemical attack of a sufficient degree may be indicated by local weakening or softening of the rope so that surface fibres can be plucked or rubbed off as a powder in extreme cases. The chemical resistance of polyester filament is in general extremely good, but hot solutions of strong alkalis progressively dissolve the fibre, causing gradual loss in mass and a corresponding fall in breaking load. It is advisable, therefore, to avoid exposure to alkaline conditions.

Resistance to acids and particularly to sulfuric acid is good, although the concentration should not be allowed to exceed about 80 %. Thus, even dilute solutions of sulfuric acid should not be allowed to dry on a rope. If any contamination is suspected, the rope should be washed out well in cold water. If there is any doubt after subsequent careful inspection, the rope should be discarded.

Resistance to hydrocarbon oils and common organic solvents is good, although polyester filament may swell in certain chlorinated solvents. Attack by concentrated phenols is severe and contact should be avoided.

Annex ZA (informative)

Clauses of this European Standard addressing essential requirements or other provisions of EU Directives

This European Standard has been prepared under a mandate given to CEN by the European Commission and the European Free Trade Association and supports essential requirements of EU Directive 89/686/EEC.

WARNING. Other requirements and other EU Directives may be applicable to the product(s) falling within the scope of this European Standard.

The following clauses of this European Standard are likely to support requirements of Directive 89/686/EEC, Annex II:

EU-Directive 89/686/EEC, Annex II	Clauses of this European Standard
1.1.1 Ergonomics	4 and 5
1.1.2 Levels and classes of protection	3.4, 3.5, 4.9, 4.10, 4.11, 4.12, 5.8, 5.9, 6.2, 6.3 and 7
1.3.2 Lightness and design strength	4.8, 4.9, 4.11, 4.12, 5.8, 5.9 and 5.10
1.4 Information supplied by the manufacturer	6 and 7
2.4 PPE subject to ageing	7
2.12 PPE bearing one or more identification or recognition marks directly or indirectly relating to health and safety	6
3.1.2.2 Prevention of falls from a height	4 and 5

Compliance with the clauses of this European Standard provides one means of conforming with the specific essential requirements of the Directive concerned and associated EFTA regulations.

BSI — British Standards Institution

BSI is the independent national body responsible for preparing British Standards. It presents the UK view on standards in Europe and at the international level. It is incorporated by Royal Charter.

Revisions

British Standards are updated by amendment or revision. Users of British Standards should make sure that they possess the latest amendments or editions.

It is the constant aim of BSI to improve the quality of our products and services. We would be grateful if anyone finding an inaccuracy or ambiguity while using this British Standard would inform the Secretary of the technical committee responsible, the identity of which can be found on the inside front cover. Tel: 020 8996 9000. Fax: 020 8996 7400.

BSI offers members an individual updating service called PLUS which ensures that subscribers automatically receive the latest editions of standards.

Buying standards

Orders for all BSI, international and foreign standards publications should be addressed to Customer Services. Tel: 020 8996 9001. Fax: 020 8996 7001.

In response to orders for international standards, it is BSI policy to supply the BSI implementation of those that have been published as British Standards, unless otherwise requested.

Information on standards

BSI provides a wide range of information on national, European and international standards through its Library and its Technical Help to Exporters Service. Various BSI electronic information services are also available which give details on all its products and services. Contact the Information Centre. Tel: 020 8996 7111. Fax: 020 8996 7048.

Subscribing members of BSI are kept up to date with standards developments and receive substantial discounts on the purchase price of standards. For details of these and other benefits contact Membership Administration. Tel: 020 8996 7002. Fax: 020 8996 7001.

Copyright

Copyright subsists in all BSI publications. BSI also holds the copyright, in the UK, of the publications of the international standardization bodies. Except as permitted under the Copyright, Designs and Patents Act 1988 no extract may be reproduced, stored in a retrieval system or transmitted in any form or by any means – electronic, photocopying, recording or otherwise – without prior written permission from BSI.

This does not preclude the free use, in the course of implementing the standard, of necessary details such as symbols, and size, type or grade designations. If these details are to be used for any other purpose than implementation then the prior written permission of BSI must be obtained.

If permission is granted, the terms may include royalty payments or a licensing agreement. Details and advice can be obtained from the Copyright Manager. Tel: 020 8996 7070.