

# **Performance test for prefabricated reinforced components made of autoclaved aerated concrete or lightweight aggregate concrete with open structure under predominantly longitudinal load (vertical components)**

The European Standard EN 1740:1998 has the status of a  
British Standard

ICS 91.100.30

## National foreword

This British Standard is the English language version of EN 1740:1998.

The UK participation in its preparation was entrusted to Technical Committee B/523, Prefabricated components of reinforced autoclaved aerated concrete and lightweight aggregated concrete with open structure, which has the responsibility to:

- aid enquirers to understand the text;
- present to the responsible European committee any enquiries on the interpretation, or proposals for change, and keep the UK interests informed;
- monitor related international and European developments and promulgate them in the UK.

A list of organizations represented on this committee can be obtained on request to its secretary.

### Cross-references

The British Standards which implement international or European publications referred to in this document may be found in the BSI Standards Catalogue under the section entitled “International Standards Correspondence Index”, or by using the “Find” facility of the BSI Standards Electronic Catalogue.

A British Standard does not purport to include all the necessary provisions of a contract. Users of British Standards are responsible for their correct application.

**Compliance with a British Standard does not of itself confer immunity from legal obligations.**

### Summary of pages

This document comprises a front cover, an inside front cover, the EN title page, pages 2 to 6, an inside back cover and a back cover.

### Amendments issued since publication

Amd. No.	Date	Text affected

This British Standard, having been prepared under the direction of the Sector Board for Building and Civil Engineering, was published under the authority of the Standards Board and comes into effect on 15 November 1998

© BSI 1998

ISBN 0 580 30145 1

---

ICS

Descriptors: Concrete, cellular concrete, aggregates, reinforcing materials, prefabricated elements, mechanical tests, determination, mechanical strength, breaking load

English version

**Performance test for prefabricated reinforced components made of autoclaved aerated concrete or lightweight aggregate concrete with open structure under predominantly longitudinal load  
(vertical components)**

Détermination de la résistance des éléments préfabriqués réalisés en béton cellulaire autoclavé ou en béton de granulats légers à structure ouverte sous charge longitudinale prédominante (composants verticaux)

Bestimmung des Tragverhaltens von vorgefertigten bewehrten Bauteilen aus dampfgehärtetem Porenbeton oder aus haufwerksporigem Leichtbeton unter vorwiegend in Längsrichtung wirkender Belastung (vertikale Bauteile)

This European Standard was approved by CEN on 25 March 1998.

CEN members are bound to comply with the CEN/CENELEC Internal Regulations which stipulate the conditions for giving this European Standard the status of a national standard without any alteration. Up-to-date lists and bibliographical references concerning such national standards may be obtained on application to the Central Secretariat or to any CEN member.

This European Standard exists in three official versions (English, French, German). A version in any other language made by translation under the responsibility of a CEN member into its own language and notified to the Central Secretariat has the same status as the official versions.

CEN members are the national standards bodies of Austria, Belgium, Czech Republic, Denmark, Finland, France, Germany, Greece, Iceland, Ireland, Italy, Luxembourg, Netherlands, Norway, Portugal, Spain, Sweden, Switzerland and United Kingdom.

**CEN**

European Committee for Standardization  
Comité Européen de Normalisation  
Europäisches Komitee für Normung

**Central Secretariat: rue de Stassart 36, B-1050 Brussels**

## Foreword

This European Standard has been prepared by Technical Committee CEN/TC 177, Prefabricated reinforced components of autoclaved aerated concrete or light weight aggregate concrete with open structure, the secretariat of which is held by DIN.

In order to meet the performance requirements as laid down in the product standards for prefabricated components of autoclaved aerated concrete and of lightweight aggregate concrete with open structure, a number of standardized test methods are necessary.

This European Standard shall be given the status of a national standard, either by publication of an identical text or by endorsement, at the latest by October 1998, and conflicting national standards shall be withdrawn at the latest by October 1998.

According to the CEN/CENELEC Internal Regulations, the national standards organizations of the following countries are bound to implement this European Standard: Austria, Belgium, Czech Republic, Denmark, Finland, France, Germany, Greece, Iceland, Ireland, Italy, Luxembourg, Netherlands, Norway, Portugal, Spain, Sweden, Switzerland and the United Kingdom.

## Contents

	Page
Foreword	2
1 Scope	3
2 Normative references	3
3 Principle	3
4 Apparatus	3
5 Test specimens	3
5.1 Sample	3
5.2 Measurement of component	3
5.3 Conditioning of component	3
6 Load test	4
6.1 Temperature conditions	4
6.2 Support conditions	4
6.3 Loading arrangement	4
6.4 Testing procedure	4
7 Observations and measurements after the load test	6
8 Test report	6

## 1 Scope

This European Standard specifies a method of determining the mechanical performances of prefabricated components made of autoclaved aerated concrete (AAC) according to prEN 12602 or lightweight aggregate concrete with open structure (LAC) according to prEN 1520, under longitudinal load which may be combined with transverse load. These performances include:

- the deflections and maximum crack width in the serviceability limit state;
- the loadbearing capacity (failure load);
- the load-(vertical)deformation diagram, if required.

## 2 Normative references

This European Standard incorporates by dated or undated reference, provisions from other publications. These normative references are cited at the appropriate places in the text, and the publications are listed hereafter.

For dated references, subsequent amendments to or revisions of any of these publications apply to this European Standard only when incorporated in it by amendment or revision. For undated references the latest edition of the publication referred to applies.

EN 678, *Determination of dry density of autoclaved aerated concrete.*

EN 679, *Determination of the compressive strength of autoclaved aerated concrete.*

EN 991, *Determination of the dimensions of prefabricated reinforced components of autoclaved aerated concrete or lightweight aggregate concrete with open structure.*

EN 992, *Determination of dry density of lightweight aggregate concrete with open structure.*

EN 1353, *Determination of moisture content of autoclaved aerated concrete.*

EN 1354, *Determination of compressive strength of lightweight aggregate concrete with open structure.*

prEN 1520, *Prefabricated components of lightweight aggregate concrete with open structure.*

prEN 12602, *Prefabricated reinforced components of autoclaved aerated concrete.*

## 3 Principle

The component is simply supported at its ends in a vertical position and loaded until collapse by a vertical line load with the required eccentricity with respect to the plane of the component, in order to determine the deflection, cracking behaviour, and the loadbearing capacity.

Alternatively, the support at the bottom of the component may be chosen as a rigid support.

The component may be loaded additionally in a horizontal direction by two line loads acting in the outer quarter points of the span and distributed over the full width of the component through rigid steel sections.

## 4 Apparatus

- a) a *device for applying the load* continuously and without shock, with an accuracy of 3 %;
- b) *devices for distributing the vertical load* and, if required, the vertical support reaction uniformly over the width of the component through pivot arrangements consisting of a steel rod, resting in v-shaped notches of flat steel bars or held otherwise in lateral direction, and two sufficiently stiff load-distribution plates, all these parts extending over the full width of the component (see Figure 1);
- c) a *device for measuring the horizontal midspan deflection* to an accuracy of 0,01 mm;
- d) (optional) a *device for measuring the vertical compression* (compressive strain) at midheight near the vertical edges of both faces of the component over a gauge length of at least 150 mm to an accuracy of 0,01 mm;
- e) a *device for measuring the camber* (deflection at midspan in unloaded state before testing), if any, to an accuracy of 1 mm;
- f) a *device for determining the weight of the component* to an accuracy of 3 %, if required.

## 5 Test specimens

### 5.1 Sample

The test specimen is a prefabricated reinforced component (whole unit).

It shall be selected in such a manner that it is representative of the product to be investigated.

### 5.2 Measurement of component

Before the load test, the dimensions of the component shall be measured according to EN 991 and, if required, its weight shall be determined to an accuracy of 3 %.

The camber at midspan in unloaded state before testing (e.g. due to non-uniform shrinkage) shall be measured to an accuracy of 1 mm while the component is resting without restraint on one of its edges in vertical position.

### 5.3 Conditioning of component

The component shall not be frozen during the load test, and large temperature and moisture gradients within the component shall be avoided.

## 6 Load test

### 6.1 Temperature conditions

The test may be carried out at any temperature of the test premises between +5 °C and +40 °C. If the temperature differs by more than  $\pm 5$  °C from +20 °C, this shall be indicated in the test report.

### 6.2 Support conditions

The supports for the longitudinal load shall be horizontal and extend across the full width of the component.

The load and the reaction forces shall be uniformly distributed over the width of the component. If the end faces of the component are not sufficiently plane, equalizing layers, e.g. consisting of a gypsum or mortar bed or a layer of soft fibre board, shall be provided between the end faces of the component and the load-distribution plates, according to 4b).

If an additional transverse load is applied, the component shall be simply supported at both ends in a horizontal direction, and at least one of the supports (that at the end where the vertical load is applied) shall be moveable in vertical direction.

The actual support conditions (including any equalizing layers) shall be described in the test report.

### 6.3 Loading arrangement

The longitudinal load shall be applied as a line load acting parallel to the plane of the component and being uniformly distributed over the width, with the required eccentricity  $e$ , if any, perpendicular to the plane of the component (see note). Attention shall be paid that any curvature or camber acts in the same sense as the required eccentricity. The eccentricity in the plane of the component (in the direction of the width) shall be zero.

The eccentricity of the load and of the support reaction shall be adjusted to an accuracy of  $\pm 2$  mm.

A typical loading arrangement is shown in Figure 1. If required, additional horizontal loads shall be applied in the outer quarter points of the span and distributed over the whole width of the component by means of rigid steel profiles.

The actual loading arrangement shall be described and illustrated in the test report.

NOTE Usually the same eccentricity is chosen at both ends.

### 6.4 Testing procedure

After placing the component in the loading device in a vertical position, the required eccentricity of the support and the load shall be adjusted to an accuracy of  $\pm 2$  mm. The devices for measuring horizontal deflections and vertical deformation (optional) at midheight shall be arranged according to Figure 1. The zero readings shall be made after application of a preload of about (1 to 5) kN.

In the case of combined vertical and horizontal loads, their concurrence shall be specified, and the loading sequence shall be defined.

The load shall be applied in appropriate steps (approximately 1/10 of the expected loadbearing capacity) up to the failure load. The loading rate shall be such that the failure load is reached within (20 to 30) min. The deflection and the vertical deformation (optional) shall be measured for at least four steps below and four steps above the serviceability limit state. Between steps, the load shall be increased continuously and without shock. The required level shall be reached within (25 to 35) s and then be maintained constant for 2 min. The deflection and vertical deformation (optional) shall be read after these 2 min.

The test shall be performed in such a manner that the following data can be determined:

- loadbearing capacity (failure load);
- load-deflection and (optional) load-(vertical)deformation diagrams;
- development of cracking and failure.

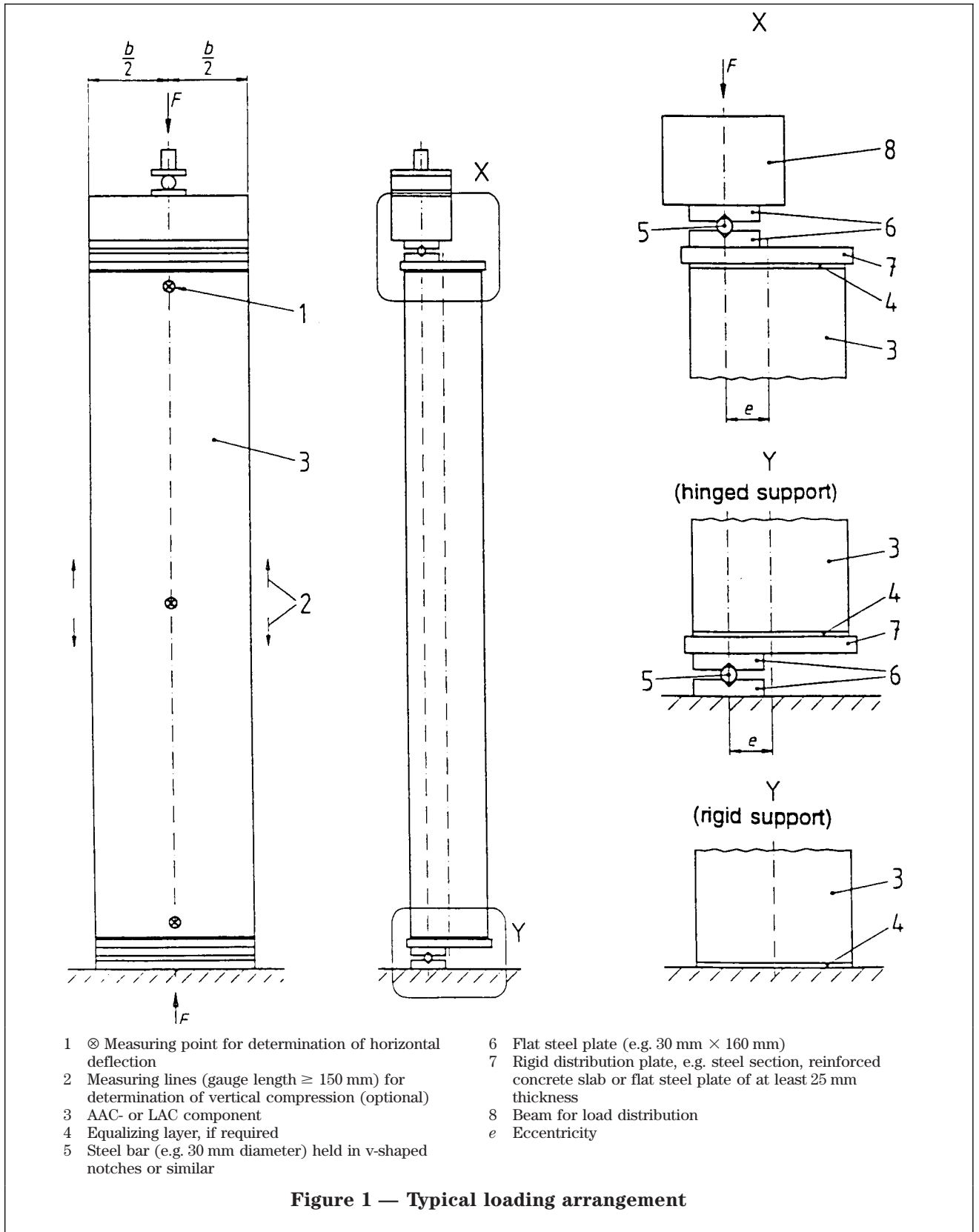



## 7 Observations and measurements after the load test

After failure of the component, the following observations and measurements shall be made:

- position and shape of fracture;
- type of reinforcement;
- number, diameter, and cover of the reinforcing bars;
- thickness of individual concrete layers in the case of multilayer components;
- compressive strength of concrete according to EN 679 or EN 1354, respectively;
- dry density of concrete according to EN 678 or EN 992, respectively;
- mass related moisture content of concrete at time of testing for AAC according to EN 1353 or for LAC on the basis of EN 992 and the following provisions:

The test specimens for the determination of the dry density shall be taken in such a way that the moisture content is influenced as little as possible (e.g. no water cooling when cutting or drilling). Immediately after the preparation of the test specimens, before any loss of moisture has occurred, the mass  $m_{\text{hum}}$  of the individual test specimens in the moist state shall be determined to an accuracy of 0,1 %.

The mass related moisture content is calculated according to equation (1):

$$\mu_{\text{m}} = 100 \frac{m_{\text{hum}} - m_{\text{dry}}}{m_{\text{dry}}} \quad (1)$$

where:

- $\mu_{\text{m}}$  is the mass related moisture content, in per cent;
- $m_{\text{hum}}$  is the mass of the test specimen in the moist state, according to EN 992, in kilograms;
- $m_{\text{dry}}$  is the mass of the dried test specimen according to EN 992, in kilograms.

## 8 Test report

The test report shall include the following:

- a) description of the component according to the relevant product standard;
- b) date of manufacture or other code;
- c) date of sampling;
- d) place and date of testing, testing institute, and person responsible for testing;
- e) number and date of issue of this European Standard;
- f) observed damages, if any, to the component prior to testing;
- g) weight of component at time of testing, if required, and main dimensions;
- h) temperature of test premises, when differing by more than  $\pm 5$  °C from +20 °C;
- i) description of actual loading arrangement and of support conditions; illustration by means of a drawing or a photograph is recommended;
- j) eccentricity of vertical load and of vertical support reaction, type of vertical support (rigid or hinged);
- k) arrangement and magnitude of any horizontal loads, horizontal support conditions;
- l) camber (deflection at midspan in unloaded state);
- m) loading sequence and loading rate;
- n) deflection and vertical deformation (optional) corresponding to the serviceability limit state;
- o) load corresponding to the formation of the first crack and of any irregularities;
- p) ultimate load (loadbearing capacity);
- q) deflection at midheight as a function of the load (graph or table);
- r) (optional) vertical deformation at midheight (individual values of the four gauge lines) as a function of the load (graph or table);
- s) position and shape of fracture;
- t) type of reinforcement, number, diameter, and cover of reinforcing bars;
- u) thickness of individual concrete layers, in case of multilayer components;
- v) compressive strength, dry density, and moisture content of concrete;
- w) observations of the appearance of the component during and after the test;
- x) (if appropriate) deviations from the standard method of testing;
- y) a declaration that the testing has been carried out in accordance with this European Standard except as detailed in 8x).





---

# BSI — British Standards Institution

BSI is the independent national body responsible for preparing British Standards. It presents the UK view on standards in Europe and at the international level. It is incorporated by Royal Charter.

## Revisions

British Standards are updated by amendment or revision. Users of British Standards should make sure that they possess the latest amendments or editions.

It is the constant aim of BSI to improve the quality of our products and services. We would be grateful if anyone finding an inaccuracy or ambiguity while using this British Standard would inform the Secretary of the technical committee responsible, the identity of which can be found on the inside front cover. Tel: 020 8996 9000. Fax: 020 8996 7400.

BSI offers members an individual updating service called PLUS which ensures that subscribers automatically receive the latest editions of standards.

## Buying standards

Orders for all BSI, international and foreign standards publications should be addressed to Customer Services. Tel: 020 8996 9001. Fax: 020 8996 7001.

In response to orders for international standards, it is BSI policy to supply the BSI implementation of those that have been published as British Standards, unless otherwise requested.

## Information on standards

BSI provides a wide range of information on national, European and international standards through its Library and its Technical Help to Exporters Service. Various BSI electronic information services are also available which give details on all its products and services. Contact the Information Centre. Tel: 020 8996 7111. Fax: 020 8996 7048.

Subscribing members of BSI are kept up to date with standards developments and receive substantial discounts on the purchase price of standards. For details of these and other benefits contact Membership Administration. Tel: 020 8996 7002. Fax: 020 8996 7001.

## Copyright

Copyright subsists in all BSI publications. BSI also holds the copyright, in the UK, of the publications of the international standardization bodies. Except as permitted under the Copyright, Designs and Patents Act 1988 no extract may be reproduced, stored in a retrieval system or transmitted in any form or by any means – electronic, photocopying, recording or otherwise – without prior written permission from BSI.

This does not preclude the free use, in the course of implementing the standard, of necessary details such as symbols, and size, type or grade designations. If these details are to be used for any other purpose than implementation then the prior written permission of BSI must be obtained.

If permission is granted, the terms may include royalty payments or a licensing agreement. Details and advice can be obtained from the Copyright Manager. Tel: 020 8996 7070.