

Determination of shear strength for in-plane forces of joints between prefabricated components of autoclaved aerated concrete or lightweight aggregate concrete with open structure

The European Standard EN 1739:2007 has the status of a British Standard

ICS 91.100.30

National foreword

This British Standard was published by BSI. It is the UK implementation of EN 1739:2007. It supersedes BS EN 1739:1998 which is withdrawn.

The UK participation in its preparation was entrusted to Technical Committee B/523, Prefabricated components of reinforced autoclaved aerated concrete and lightweight aggregate concrete with open structure.

A list of organizations represented on this committee can be obtained on request to its secretary.

This publication does not purport to include all the necessary provisions of a contract. Users are responsible for its correct application.

Compliance with a British Standard cannot confer immunity from legal obligations.

This British Standard was published under the authority of the Standards Policy and Strategy Committee on 30 April 2007

© BSI 2007

ISBN 978 0 580 50626 0

Amendments issued since publication

Amd. No.	Date	Comments

English Version

Determination of shear strength for in-plane forces of joints between prefabricated components of autoclaved aerated concrete or lightweight aggregate concrete with open structure

Détermination de la résistance au cisaillement des jonctions entre des éléments préfabriqués réalisés en béton cellulaire autoclavé ou en béton de granulats légers à structure ouverte, sous l'effet de forces agissant dans le plan des éléments

Bestimmung der Schubtragfähigkeit von Fugen zwischen vorgefertigten Bauteilen aus dampfgehärtetem Porenbeton oder haufwerksporigem Leichtbeton bei Belastung in Bauteilebene

This European Standard was approved by CEN on 24 February 2007.

CEN members are bound to comply with the CEN/CENELEC Internal Regulations which stipulate the conditions for giving this European Standard the status of a national standard without any alteration. Up-to-date lists and bibliographical references concerning such national standards may be obtained on application to the CEN Management Centre or to any CEN member.

This European Standard exists in three official versions (English, French, German). A version in any other language made by translation under the responsibility of a CEN member into its own language and notified to the CEN Management Centre has the same status as the official versions.

CEN members are the national standards bodies of Austria, Belgium, Bulgaria, Cyprus, Czech Republic, Denmark, Estonia, Finland, France, Germany, Greece, Hungary, Iceland, Ireland, Italy, Latvia, Lithuania, Luxembourg, Malta, Netherlands, Norway, Poland, Portugal, Romania, Slovakia, Slovenia, Spain, Sweden, Switzerland and United Kingdom.



EUROPEAN COMMITTEE FOR STANDARDIZATION
COMITÉ EUROPÉEN DE NORMALISATION
EUROPÄISCHES KOMITEE FÜR NORMUNG

Management Centre: rue de Stassart, 36 B-1050 Brussels

Contents

Page

Foreword.....	3
1 Scope	4
2 Normative references	4
3 Principle	4
4 Apparatus	4
5 Test specimens	5
6 Testing procedure.....	6
7 Test results	7
8 Test report	8
Bibliography	15

Figures

Figure 1 — Example A for reference test set-up for grouted joint	9
Figure 2 — Example B for reference test set-up for grouted joint	10
Figure 3 — Example A for reference test set-up for mechanical joint	11
Figure 4 — Example B for reference test set-up for mechanical joint	12
Figure 5 — Example A for alternative test set-up.....	13
Figure 6 — Example B for alternative test set-up.....	14

Foreword

This document (EN 1739:2007) has been prepared by Technical Committee CEN/TC 177 “Prefabricated reinforced components of autoclaved aerated concrete or light-weight aggregate concrete with open structure”, the secretariat of which is held by DIN.

This European Standard shall be given the status of a national standard, either by publication of an identical text or by endorsement, at the latest by October 2007, and conflicting national standards shall be withdrawn at the latest by October 2007.

This document supersedes EN 1739:1998.

In order to meet the performance requirements as laid down in the product standards for prefabricated reinforced components of autoclaved aerated concrete and of lightweight aggregate concrete with open structure, a number of standardized test methods are necessary.

According to the CEN/CENELEC Internal Regulations, the national standards organizations of the following countries are bound to implement this European Standard: Austria, Belgium, Bulgaria, Cyprus, Czech Republic, Denmark, Estonia, Finland, France, Germany, Greece, Hungary, Iceland, Ireland, Italy, Latvia, Lithuania, Luxembourg, Malta, Netherlands, Norway, Poland, Portugal, Romania, Slovakia, Slovenia, Spain, Sweden, Switzerland and United Kingdom.

1 Scope

This European Standard specifies methods of determining the shear strength for in-plane forces of joints between prefabricated components made of autoclaved aerated concrete (AAC) according to prEN 12602 or lightweight aggregate concrete with open structure (LAC) according to EN 1520.

2 Normative references

The following referenced documents are indispensable for the application of this document. For dated references, only the edition cited applies. For undated references, the latest edition of the referenced document (including any amendments) applies.

EN 678, *Determination of the dry density of autoclaved aerated concrete*

EN 679, *Determination of the compressive strength of autoclaved aerated concrete*

EN 992, *Determination of the dry density of lightweight aggregate concrete with open structure*

EN 1353, *Determination of moisture content of autoclaved aerated concrete*

EN 1354, *Determination of compressive strength of lightweight aggregate concrete with open structure*

3 Principle

The shear strength for in-plane forces of longitudinal joints between two adjacent prefabricated AAC- or LAC-components or sections thereof is determined by applying an in-plane shear force parallel with to the joint.

The load is increased continuously or in steps until failure of the joint. The load-displacement diagram and the failure load are determined. The shear strength is determined from the failure load.

4 Apparatus

- a) saw for cutting components and test specimens;
- b) compression testing machine or a hydraulic jack, capable of applying a compressive load without shock continuously or in steps. The precision of the compression testing machine or of the hydraulic jack and of the load indication shall be such that the failure load can be determined to an accuracy of $\pm 3\%$. The measuring range shall be such that the failure load is higher than one-tenth of the range used;
- c) callipers and/or rule, capable of measuring the dimensions of the test specimens and the joints to an accuracy of 1 mm;
- d) loading frame and/or devices (e.g. steel plates, flat steel bars, steel rollers, soft fibre board) according to Figures 1, 2, 3 or 4 (or Figures 5 or 6, for alternative tests) for transmitting the load and support reactions to the test specimen;
- e) dial gauge or a displacement transducer with a reading accuracy of 0,01 mm for measuring the relative displacement between the loaded and the supported part of the test specimen.

5 Test specimens

5.1 Sample

The sample for the preparation of the test specimens shall be taken in such a manner that it is representative of the product to be investigated. In the case of AAC, the direction of rise of the mass during manufacture shall be marked on the components.

5.2 Shape and size of test specimens

The test specimen consists of two connected parts of prefabricated reinforced components with the actual thickness t of the component and a length of $l = 150$ mm. The width of one part is $w_1 = 100$ mm and the width of the other part is $w_2 = 200$ mm, the total width of the specimen is then $w = 300$ mm plus the thickness of the joint, see Figures 1 and 2. If the joint system is mechanical, e.g. nails and plates or similar or toothed joints, the dimensions may be increased, to ensure space for the tooth or mechanical connections, as long as the ratio between the width and the length is 1 (e.g. $w = l = 600$ mm), see Figures 3 and 4.

5.3 Number of test specimens

A test set shall consist of at least three test specimens.

5.4 Preparation of test specimens

AAC shall be allowed to cool for at least 2 d after autoclaving before assembling of the two parts.

LAC test specimens shall be at least 21 d old before assembling the two parts and at least 28 d at testing.

Before jointing, length, thickness and width of the parts to be connected shall be measured. The shape and dimensions of the longitudinal faces adjacent to the joint (e.g. tongue and groove) shall also be determined. For a mechanical jointing system dimensions and material properties of all parts shall be indicated.

If the parts to be connected are frozen or cold, they shall be stored with sufficient space between each other at room temperature for at least 2 d before jointing.

In the case of a grouted joint the test specimens shall be assembled as shown in Figures 1 or 2.

If the joint system is mechanical, e.g. nails and plates or similar, the two parts shall be joined together dry, without grouting (see Figures 3 or 4). There shall be at least two mechanical fixings or grouted dowels along such a joint. Defined tolerances for the mechanical fixings may be taken into account.

If the joint is grouted with mortar or concrete, the two parts of the test specimen shall be fixed temporarily together in at least two places before grouting. After hardening of the grouting material the fixing shall be removed.

Grouting shall be performed according to the instructions of the manufacturer of the components. The grouting procedure (including e.g. any pre-wetting of the concrete adjacent to the joint), the recipe, consistency and the temperature of the grouting material shall be recorded in the test report.

A grouted joint shall be protected against moisture loss under plastic sheet immediately after grouting and shall be allowed to harden at room temperature for at least 7 d before the test.

5.5 Conditioning of test specimens

The test specimens shall be kept at room temperature before and during testing. The moisture content of the concrete at testing shall be at least 6 % by mass for AAC and at least 4 % by mass for LAC. This shall be checked after the shear test (see 6.2).

NOTE When in doubt about the moisture content, this can be estimated in advance by testing related samples of material.

5.6 Alternative test specimens

Alternative test specimens may be used, when the basic principle in this test standard is used. A correlation between the results from the alternative test method used shall be established with the reference method given above.

In Figure 5 and Figure 6 test set-ups for alternative tests are presented. The tests can be carried out with or without transverse pressure.

6 Testing procedure

6.1 Shear test

The test specimen is placed in the testing machine or loading frame as shown in Figures 1 to 6.

If the loaded and the supported surfaces of the test specimen deviate from planeness by more than 0,1 mm (to be checked over the two diagonals by means of a straight-edge and, if necessary, a feeler gauge), an intermediate layer of soft fibre board, gypsum plaster or mortar shall be applied between the concrete and the adjacent steel parts as indicated in the figures.

In the case of standard tests using a loading frame according to Figures 1 or 3, the support plate at the bottom shall be placed close to the joint, ensuring that the opposite loaded part of the test specimen can move freely downwards. The supported part shall be clamped to the support plate at bottom by tightening the clamp screw pressing on the ball-and-socket joint placed on the top of the component. This is not necessary if a test set-up according to Figures 2 or 4 is chosen.

The load shall be applied as line load parallel to the joint, reaching over the whole thickness of the test specimen. The load transmitting steel bar shall be placed close to the joint, in the specified distance from the adjoining edge of the joint (see Figure 1 to 4). It shall be capable of being inclined in a plane parallel to the joint.

A dial gauge or displacement transducer shall be installed as shown in the figures for measuring the relative displacement over the joint between the loaded and the supported part of the test specimen.

In the case of lateral supports, it shall be ensured that the supporting rollers are capable of moving smoothly to prevent any significant influence of frictional forces on test results.

After having taken an initial reading of the dial gauge or the displacement transducer, the load is applied continuously or in steps, depending on the equipment used for measuring and recording the displacement. In the case of continuous loading, the loading rate shall be chosen such that failure will occur within (10 to 20) min. In the case of incremental load application, the size of the load steps shall not exceed 1/10 of the estimated failure load. Within the individual steps the load may be applied rapidly, but without shock. The displacement gauge shall be read immediately after reaching a new load level and additionally 1 min later under the same load. The procedure shall be repeated until failure occurs. In the case of substantial creep, the load shall be kept constant, and readings shall be taken every other minute until creep ceases, but not longer than 10 min. The formation of cracks or irregularities shall be recorded in the test report.

6.2 Investigations after shear test

Observations on the extent of filling of grouted joints shall be indicated in the test report.

Samples shall be taken from the components in the vicinity of the joint to check the moisture content of the concrete. In the case of AAC this shall be done in accordance with EN 1353. In the case of LAC the procedure described in EN 1356:1996, Clause 7, may be used.

Additional samples shall be taken in order to determine the compressive strength and the dry density of the concrete. They shall be extracted from undamaged parts of the components tested or from a component or block from the same mould or mixer batch as used for the components of the shear test. The compressive strength shall be determined according to EN 679 (AAC) or EN 1354 (LAC). The dry density shall be determined according to EN 678 (AAC) or EN 992 (LAC).

Samples of mortar dowels or of the grouting material shall be taken for the determination of the density, the moisture content and the compressive strength. These properties shall be tested in accordance with relevant or the most appropriate EN test methods.

If it is not possible to determine the compressive strength of the grouting material on test specimens taken from the joints, this shall be done on prisms or cubes cast in moulds using material from the same batch as used for grouting of the joints.

7 Test results

The shear strength of the joint shall be expressed as a stress τ_u calculated according to Equations (1), (2) or (3), in Megapascals (MPa).

$$\tau_u = 1000 \frac{F_u}{l \cdot t} \quad \text{for test set-up according to Figures 1, 3, 5 or 6} \quad (1)$$

$$\tau_u = 1000 \frac{0,8F_u}{l \cdot t} \quad \text{for test set-up according to Figure 2} \quad (2)$$

$$\tau_u = 1000 F_u \frac{w_2 - 2l / 15}{w_2 \cdot l \cdot t} \quad \text{for test set-up according to Figure 4} \quad (3)$$

where

F_u is the applied load at failure, in kilonewtons;

l is the length of the joint, in millimetres;

t is the thickness of the tested specimen, in millimetres;

w_2 is the centre distance of the supports = width of the loaded part of the test specimen.

The result shall be rounded to the nearest 0 or 5 in the third significant figure (e.g. 0,55 MPa).

For each individual test a load-displacement diagram shall be reported.

8 Test report

The test report shall include the following:

- a) identification of the components;
- b) date of manufacture or other code;
- c) place and date of testing, testing institute and person responsible for testing;
- d) number and date of issue of this European Standard, i.e. EN 1739:2007;
- e) description of preparation of test specimens and of loading arrangement, including indication of direction of rise (only for AAC);
- f) drawing of joint, jointing system, load application device, and support conditions;
- g) (if used) description of the mechanical fixings and their tolerances;
- h) recipe and properties of fresh grouting material, if applicable;
- i) material specification for mechanical jointing, if applicable;
- j) load-displacement diagram for each individual test;
- k) failure load for each individual test and mean value for each test set;
- l) moisture content of AAC or LAC, respectively;
- m) density of AAC or LAC, respectively;
- n) declared compressive strength of AAC or LAC, respectively;
- o) properties of hardened grouting material if determined (age at testing, compressive strength, moisture content, density);
- p) observations during and after the test;
- q) (if appropriate) deviations from the standard method of testing, e.g. lateral forces in the case of alternative test according to Figure 5 or Figure 6);
- r) declaration that the testing has been carried out in accordance with this European Standard except as detailed in 8 q).

Dimensions in millimetres

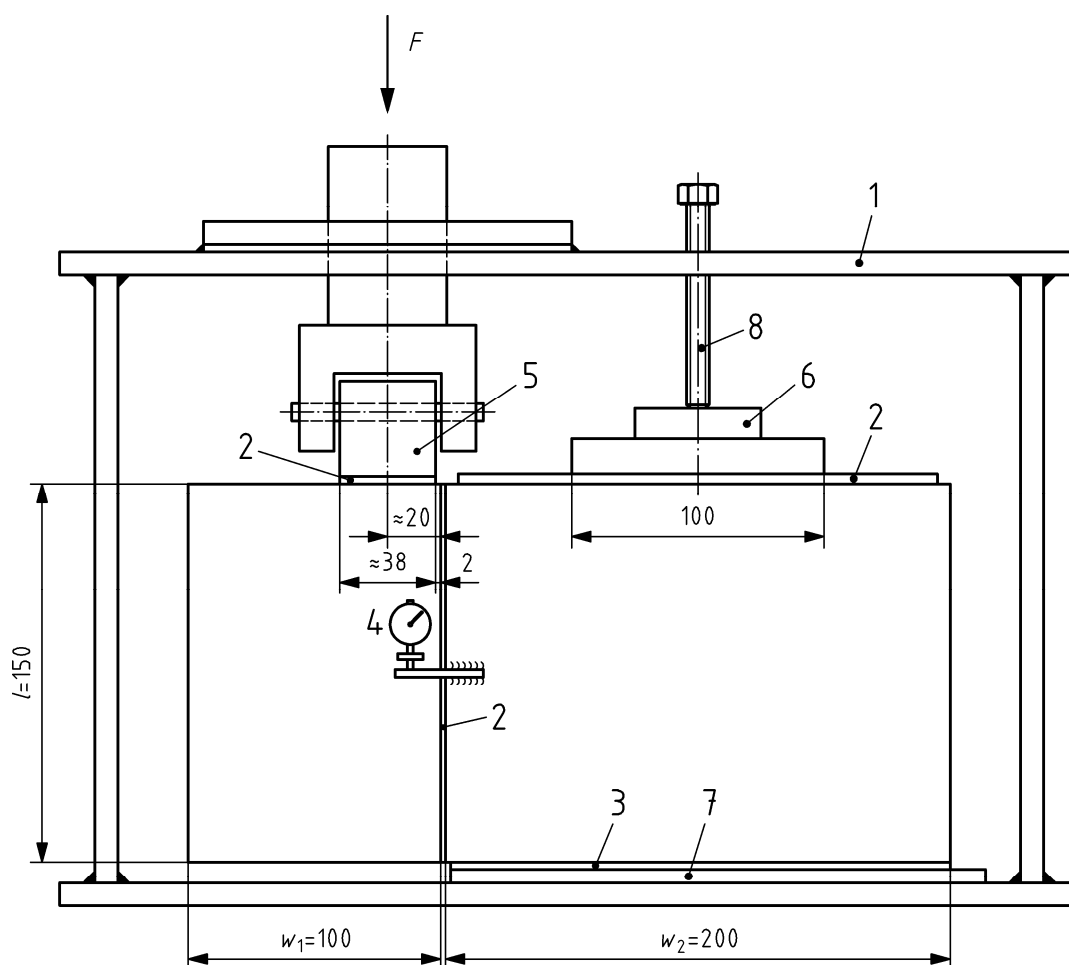
**Key**

F	force	l	Length of the joint
w_1	width of the loaded part of the test specimen	w_2	width of the supported part of the test specimen
1	loading frame	5	loading edge (flat steel bar), capable of being inclined in a plane parallel to the joint
2	joint	6	ball-and-socket joint
3	soft fibre board, gypsum plaster or mortar	7	steel plate support in full width and thickness of supported part of test specimen
4	dial gauge or displacement transducer	8	clamp screw for fixing the test specimen against tilting

Figure 1 — Example A for reference test set-up for grouted joint

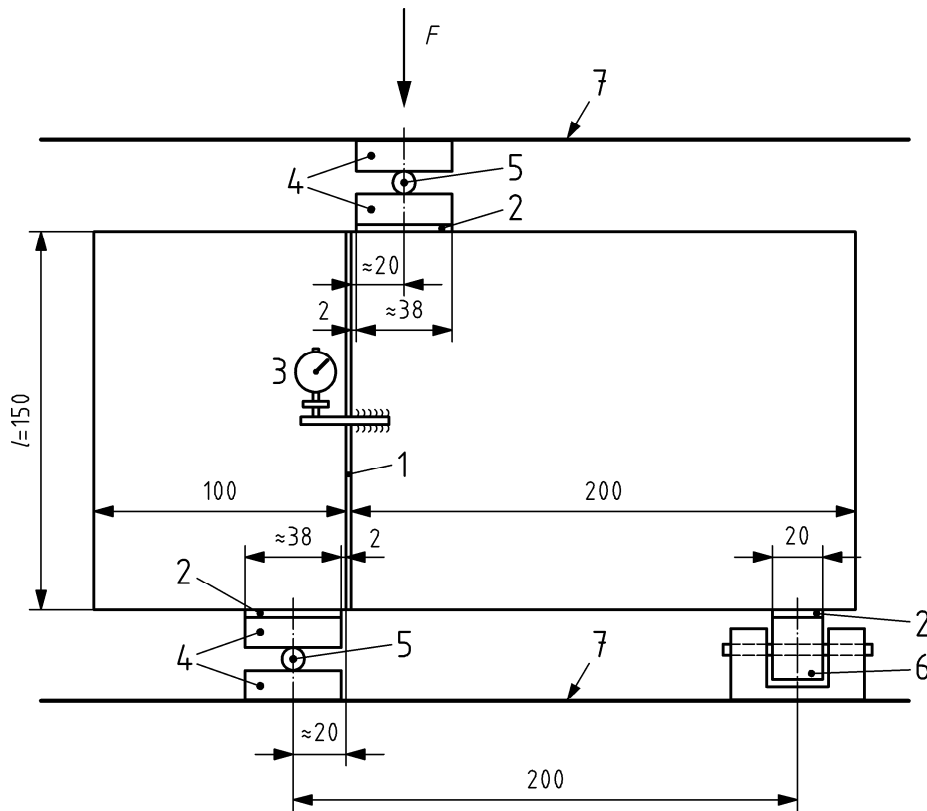

Key

- | | | | |
|-----|--|-----|--|
| F | force | l | length of the joint |
| 1 | joint | 5 | steel roller over the full thickness |
| 2 | soft fibre board, gypsum plaster or mortar | 6 | Supporting flat steel bar over the full thickness and capable of being inclined in a plane parallel to the joint |
| 3 | dial gauge or displacement transducer | 7 | Platen of the compression testing machine |
| 4 | flat steel bar over the full thickness | | |

Figure 2 — Example B for reference test set-up for grouted joint

Dimensions in millimetres

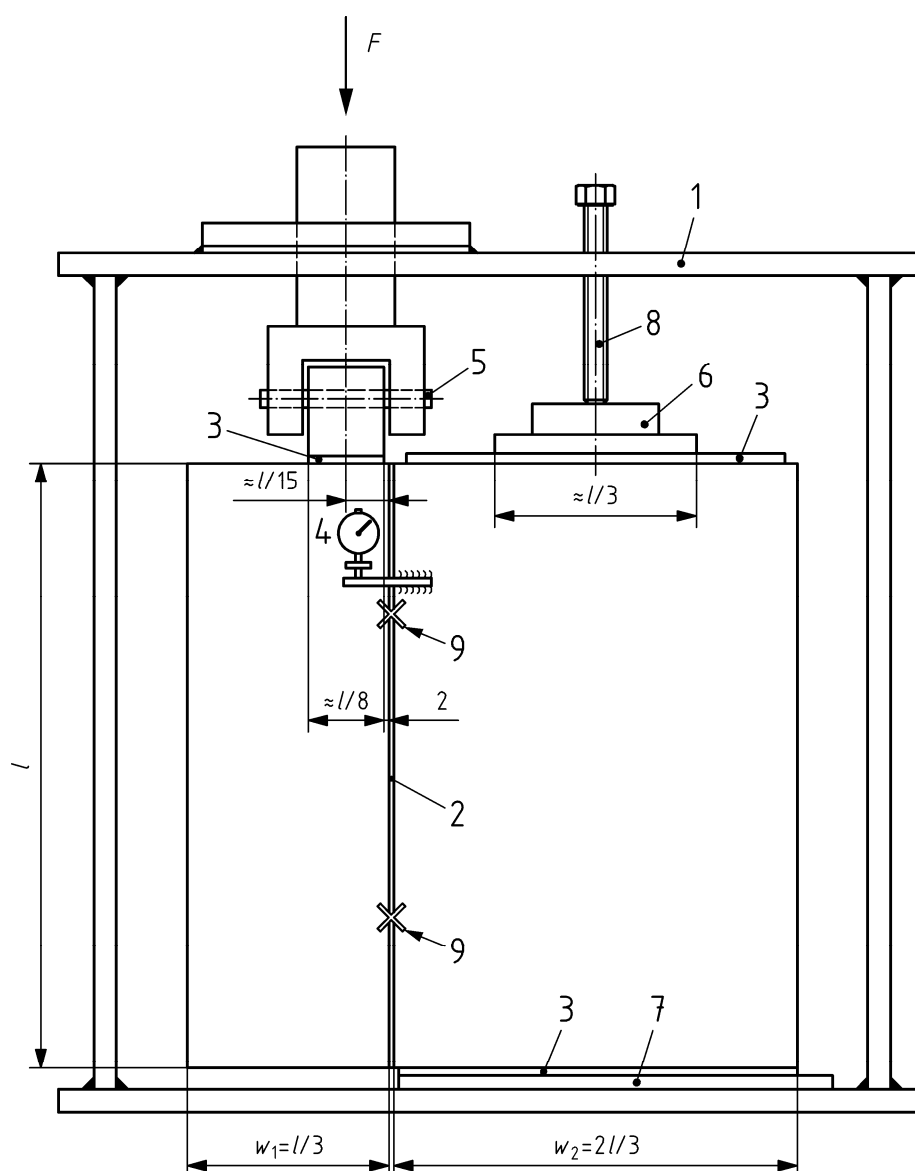
**Key**

F	force	l	length of the joint
w_1	width of the loaded part of the test specimen	w_2	width of the supported part of the test specimen
1	loading frame	5	loading edge (flat steel bar), capable of being inclined in a plane parallel to the joint
2	joint	6	ball-and-socket joint
3	soft fibre board, gypsum plaster or mortar	7	steel plate support in full width and thickness of supported part of test specimen
4	dial gauge or displacement transducer	8	clamp screw for fixing the test specimen against tilting
		9	mechanical connection

Figure 3 — Example A for reference test set-up for mechanical joint

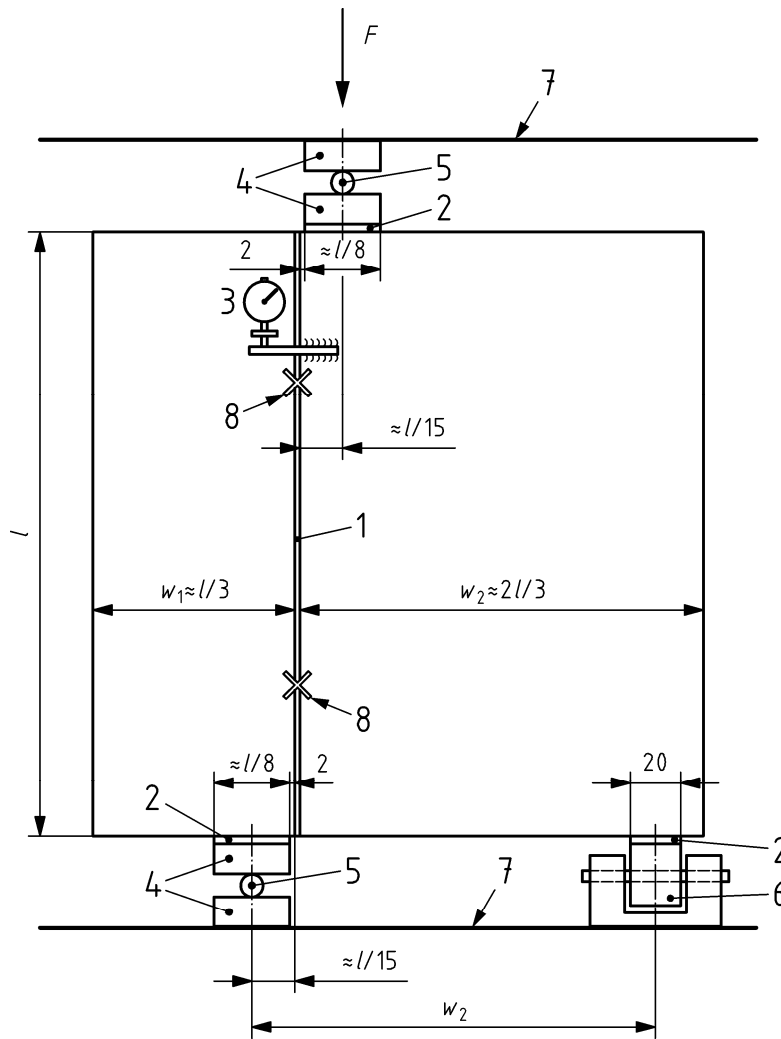

Key

- | | |
|---|--|
| F force | l length of the joint |
| w_1 width of the unloaded part of the test specimen | w_2 width of the loaded part of the test specimen |
| 1 joint | 5 steel roller over the full thickness |
| 2 soft fibre board, gypsum plaster or mortar | 6 supporting flat steel bar over the full thickness and capable of being inclined in a plane parallel to the joint |
| 3 dial gauge or displacement transducer | 7 platen of the compression testing machine |
| 4 flat steel bar over the full thickness | |

Figure 4 — Example B for reference test set-up for mechanical joint

Dimensions in millimetres

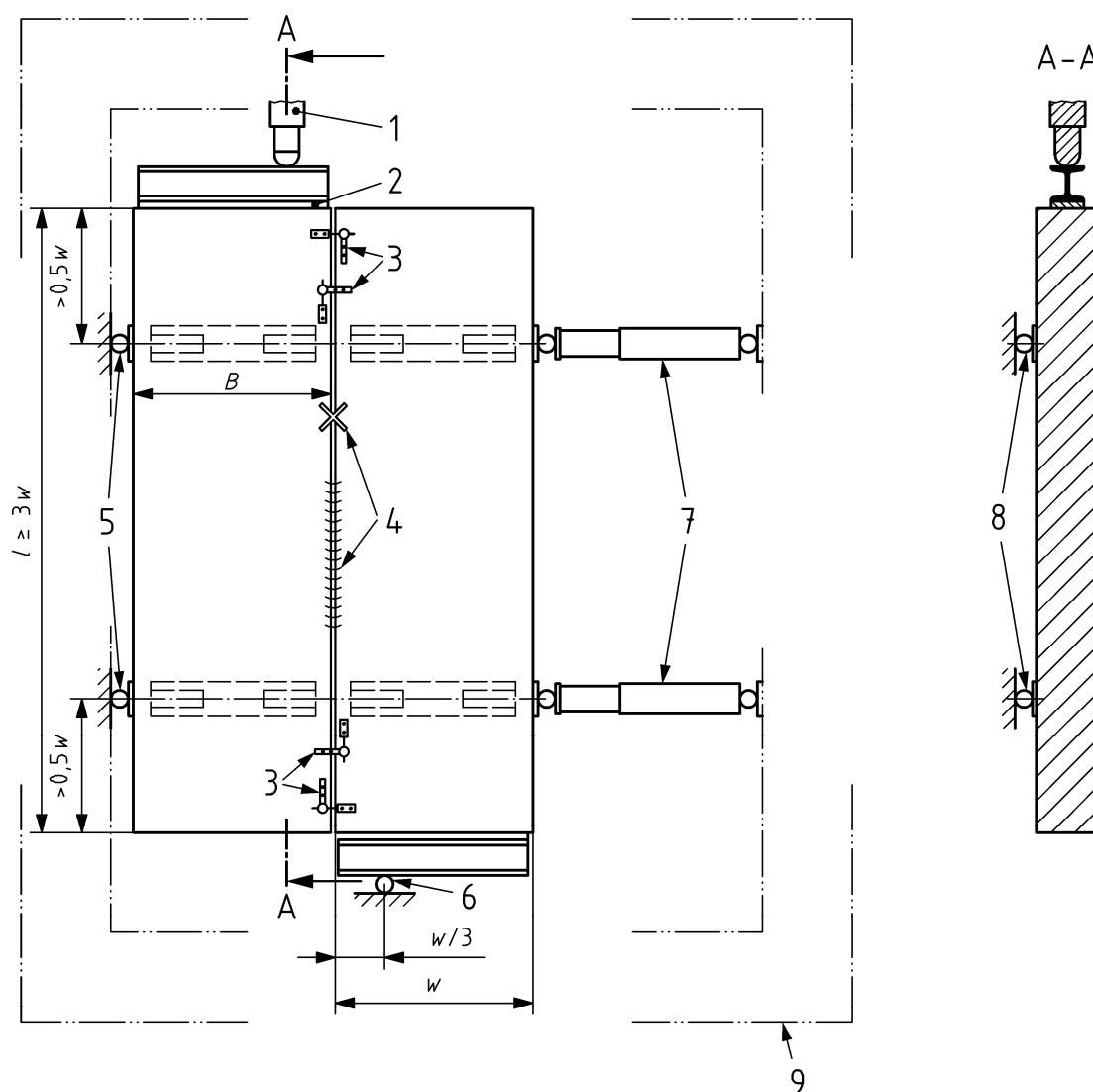
**Key**

- 1 hydraulic jack
- 2 soft fibre board
- 3 dial gauge or displacement transducer
- 4 mechanical or continuous connection
- 5 lateral supports
- 6 steel roller
- 7 jack or force gauge
- 8 steel rollers \varnothing 40 mm
- 9 steel frame if necessary

Figure 5 — Example A for alternative test set-up

Dimensions in millimetres

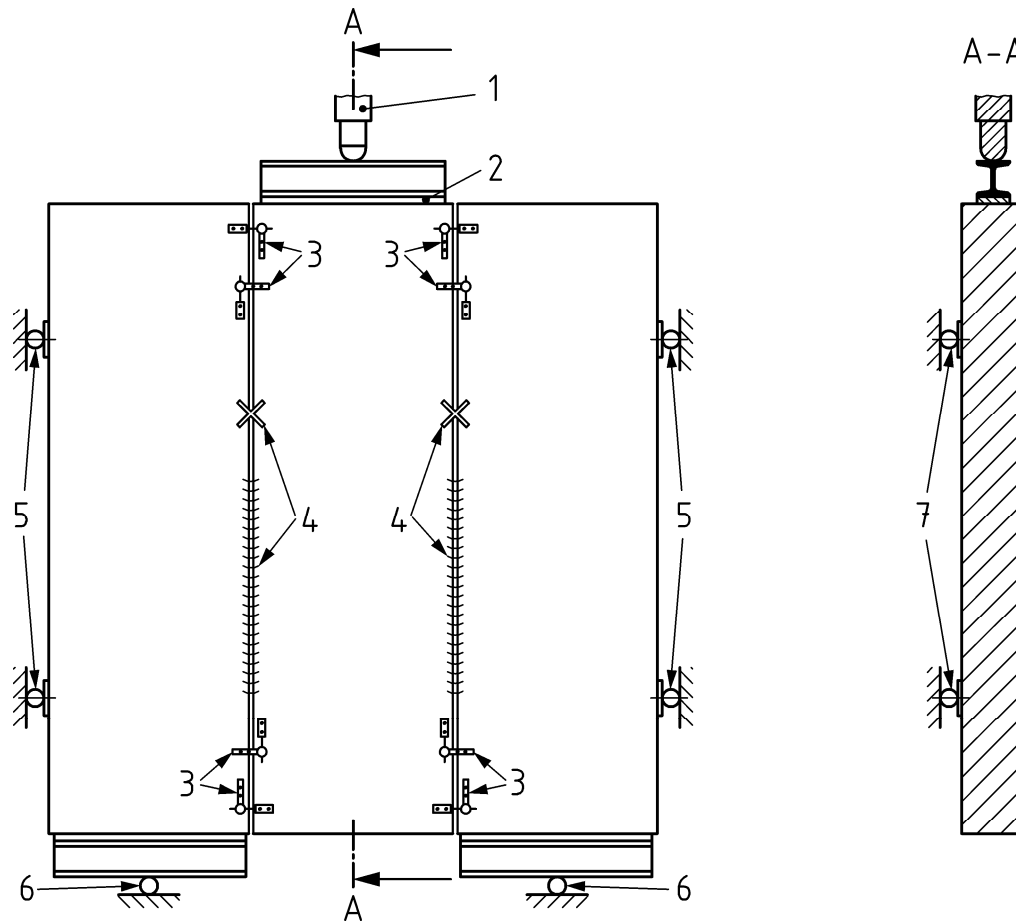

Key

- 1 hydraulic jack
- 2 soft fibre board
- 3 dial gauge or displacement transducer
- 4 mechanical or continuous connection
- 5 lateral supports with force gauge if necessary
- 6 steel roller
- 7 steel rollers \varnothing 40 mm

Figure 6 — Example B for alternative test set-up

Bibliography

- [1] EN 1520, *Prefabricated reinforced components of lightweight aggregate concrete with open structure*
- [2] prEN 12602, *Prefabricated reinforced components of autoclaved aerated concrete*
- [3] EN 1356:1996, *Performance test for prefabricated reinforced components of autoclaved aerated concrete or lightweight aggregate concrete with open structure under transverse load*

BSI — British Standards Institution

BSI is the independent national body responsible for preparing British Standards. It presents the UK view on standards in Europe and at the international level. It is incorporated by Royal Charter.

Revisions

British Standards are updated by amendment or revision. Users of British Standards should make sure that they possess the latest amendments or editions.

It is the constant aim of BSI to improve the quality of our products and services. We would be grateful if anyone finding an inaccuracy or ambiguity while using this British Standard would inform the Secretary of the technical committee responsible, the identity of which can be found on the inside front cover.
Tel: +44 (0)20 8996 9000. Fax: +44 (0)20 8996 7400.

BSI offers members an individual updating service called PLUS which ensures that subscribers automatically receive the latest editions of standards.

Buying standards

Orders for all BSI, international and foreign standards publications should be addressed to Customer Services. Tel: +44 (0)20 8996 9001.
Fax: +44 (0)20 8996 7001. Email: orders@bsi-global.com. Standards are also available from the BSI website at <http://www.bsi-global.com>.

In response to orders for international standards, it is BSI policy to supply the BSI implementation of those that have been published as British Standards, unless otherwise requested.

Information on standards

BSI provides a wide range of information on national, European and international standards through its Library and its Technical Help to Exporters Service. Various BSI electronic information services are also available which give details on all its products and services. Contact the Information Centre.
Tel: +44 (0)20 8996 7111. Fax: +44 (0)20 8996 7048. Email: info@bsi-global.com.

Subscribing members of BSI are kept up to date with standards developments and receive substantial discounts on the purchase price of standards. For details of these and other benefits contact Membership Administration.
Tel: +44 (0)20 8996 7002. Fax: +44 (0)20 8996 7001.
Email: membership@bsi-global.com.

Information regarding online access to British Standards via British Standards Online can be found at <http://www.bsi-global.com/bsonline>.

Further information about BSI is available on the BSI website at <http://www.bsi-global.com>.

Copyright

Copyright subsists in all BSI publications. BSI also holds the copyright, in the UK, of the publications of the international standardization bodies. Except as permitted under the Copyright, Designs and Patents Act 1988 no extract may be reproduced, stored in a retrieval system or transmitted in any form or by any means – electronic, photocopying, recording or otherwise – without prior written permission from BSI.

This does not preclude the free use, in the course of implementing the standard, of necessary details such as symbols, and size, type or grade designations. If these details are to be used for any other purpose than implementation then the prior written permission of BSI must be obtained.

Details and advice can be obtained from the Copyright & Licensing Manager.
Tel: +44 (0)20 8996 7070. Fax: +44 (0)20 8996 7553.
Email: copyright@bsi-global.com.