

BS EN 1621-2:2014



BSI Standards Publication

Motorcyclists' protective clothing against mechanical impact

Part 2: Motorcyclists' back protectors — Requirements and test methods

bsi.

...making excellence a habit.™

National foreword

This British Standard is the UK implementation of EN 1621-2:2014. It supersedes BS EN 1621-2:2003 which is withdrawn.

The UK participation in its preparation was entrusted to Technical Committee PH/3/9, Motorcyclists Personal Protective Equipment.

A list of organizations represented on this committee can be obtained on request to its secretary.

This publication does not purport to include all the necessary provisions of a contract. Users are responsible for its correct application.

© The British Standards Institution 2014. Published by BSI Standards Limited 2014

ISBN 978 0 580 77774 5

ICS 13.340.10

Compliance with a British Standard cannot confer immunity from legal obligations.

This British Standard was published under the authority of the Standards Policy and Strategy Committee on 28 February 2014.

Amendments issued since publication

Date	Text affected
------	---------------

EUROPEAN STANDARD

EN 1621-2

NORME EUROPÉENNE

EUROPÄISCHE NORM

January 2014

ICS 13.340.10

Supersedes EN 1621-2:2003

English Version

Motorcyclists' protective clothing against mechanical impact - Part 2: Motorcyclists' back protectors - Requirements and test methods

Vêtements de protection contre les chocs mécaniques pour
motocyclistes - Partie 2 : Protecteurs dorsaux - Exigences
et méthodes d'essai

Motorradfahrer-Schutzkleidung gegen mechanische
Belastung - Teil 2: Rückenprotektoren - Anforderungen und
Prüfverfahren

This European Standard was approved by CEN on 26 October 2013.

CEN members are bound to comply with the CEN/CENELEC Internal Regulations which stipulate the conditions for giving this European Standard the status of a national standard without any alteration. Up-to-date lists and bibliographical references concerning such national standards may be obtained on application to the CEN-CENELEC Management Centre or to any CEN member.

This European Standard exists in three official versions (English, French, German). A version in any other language made by translation under the responsibility of a CEN member into its own language and notified to the CEN-CENELEC Management Centre has the same status as the official versions.

CEN members are the national standards bodies of Austria, Belgium, Bulgaria, Croatia, Cyprus, Czech Republic, Denmark, Estonia, Finland, Former Yugoslav Republic of Macedonia, France, Germany, Greece, Hungary, Iceland, Ireland, Italy, Latvia, Lithuania, Luxembourg, Malta, Netherlands, Norway, Poland, Portugal, Romania, Slovakia, Slovenia, Spain, Sweden, Switzerland, Turkey and United Kingdom.



EUROPEAN COMMITTEE FOR STANDARDIZATION
COMITÉ EUROPÉEN DE NORMALISATION
EUROPÄISCHES KOMITEE FÜR NORMUNG

CEN-CENELEC Management Centre: Avenue Marnix 17, B-1000 Brussels

Contents

Page

Foreword.....	3
Introduction	4
1 Scope	5
2 Normative references	5
3 Terms and definitions	5
4 Requirements	6
4.1 General.....	6
4.2 Innocuousness.....	6
4.3 Minimum dimensions of zones of protection	6
4.4 Impact attenuation	7
4.5 Ergonomic requirements	8
4.6 Sizing and size marking	8
5 Test methods and equipment.....	8
5.1 Impact attenuation	8
5.1.1 Equipment	8
5.1.2 Templates	9
5.1.3 Number of samples.....	10
5.1.4 Number of tests.....	10
5.1.5 Procedure	10
5.1.6 Tests.....	12
5.2 Ergonomic assessment	13
5.2.1 General.....	13
5.2.2 Tests.....	13
5.3 Expression of test results	14
5.4 Test report	14
6 Marking	14
7 Information supplied by the manufacturer	15
Annex A (informative) Method of metrological confirmation.....	18
A.1 Method of metrological confirmation	18
A.2 Reference material.....	18
A.3 Preparation of the test sample	18
A.4 Procedure	18
A.5 Calculation.....	18
A.6 Precision.....	19
Annex ZA (informative) Relationship between this European Standard and the Essential Requirements of EU Directive 89/686/EEC.....	20
Bibliography	21

Foreword

This document (EN 1621-2:2014) has been prepared by Technical Committee CEN/TC 162 "Protective clothing including hand and arm protection and lifejackets", the secretariat of which is held by DIN.

This European Standard shall be given the status of a national standard, either by publication of an identical text or by endorsement, at the latest by July 2014, and conflicting national standards shall be withdrawn at the latest by July 2014.

Attention is drawn to the possibility that some of the elements of this document may be the subject of patent rights. CEN [and/or CENELEC] shall not be held responsible for identifying any or all such patent rights.

This document supersedes EN 1621-2:2003.

This document has been prepared under a mandate given to CEN by the European Commission and the European Free Trade Association, and supports essential requirements of EU Directive(s).

For relationship with EU Directive 89/686/EEC, see informative Annex ZA, which is an integral part of this document.

The main technical changes with respect to the 2003 edition are listed below:

- a new shape of protector has been added, the central back protector;
- requirements concerning innocuousness have been added;
- requirements concerning the wet impact test (mandatory) and the high and low temperature impact tests (optional) have been added;
- the waist to shoulder length shall be specified as a range.

EN 1621 consists of the following parts, under the general title *Motorcyclists' protective clothing against mechanical impact*:

- *Part 1: Motorcyclists' limb joint impact protectors — Requirements and test methods*
- *Part 2: Motorcyclists' back protectors — Requirements and test methods* (the present document)
- *Part 3: Requirements and test methods for chest protectors*¹⁾
- *Part 4: Motorcyclists' inflatable protectors — Requirements and test methods*

According to the CEN-CENELEC Internal Regulations, the national standards organizations of the following countries are bound to implement this European Standard: Austria, Belgium, Bulgaria, Croatia, Cyprus, Czech Republic, Denmark, Estonia, Finland, Former Yugoslav Republic of Macedonia, France, Germany, Greece, Hungary, Iceland, Ireland, Italy, Latvia, Lithuania, Luxembourg, Malta, Netherlands, Norway, Poland, Portugal, Romania, Slovakia, Slovenia, Spain, Sweden, Switzerland, Turkey and the United Kingdom.

1) Under development.

Introduction

Motorcyclist's back protectors are devices worn within or on top of other protective clothing, covering at least a portion of the back as corresponding to one of the three shapes of protectors described in the standard.

The performance requirements have been chosen as a best practical compromise between protection, comfort, and ergonomic requirements. Protectors that are too stiff or heavy will not be worn. The test methods are designed to provide information on protection against impacts against edges such as kerb stones. The force levels in the tests do not compare directly with the forces to which riders are exposed in accidents, but experiences have shown that products meeting the requirements of this European Standard reduce the incidence and severity of injuries.

This standard accommodates three different typologies of back protector, which are offered to encourage the adoption of certified protection within the different disciplines of motorcycling and the type of rider. These are namely full back, central back and lower back (lumbar) protector, the definition of which are provided in Clause 3.

Two performance levels are specified for motorcyclist's back protectors against impacts. These are level 1 for protectors designed to give protection whilst having low ergonomic penalties associated with its use and level 2 for protectors providing an increased protection with respect to level 1. There may be, however, weight and restriction penalties associated with level 2 protection.

1 Scope

This European Standard specifies the minimum coverage to be provided by motorcyclists' back protectors worn by riders in normal traffic situations. The standard contains the requirements for the performance of the protectors under impact and details of the test methods. Requirements for sizing, ergonomic requirements, and requirements for innocuousness, labelling and the provision of information are included.

2 Normative references

The following documents, in whole or in part, are normatively referenced in this document and are indispensable for its application. For dated references, only the edition cited applies. For undated references, the latest edition of the referenced document (including any amendments) applies.

EN 1621-1, *Motorcyclists' protective clothing against mechanical impact - Part 1: Motorcyclists' limb joint impact protectors - Requirements and test methods*

ISO 6487, *Road vehicles - Measurement techniques in impact tests - Instrumentation*

3 Terms and definitions

For the purposes of this document, the following terms and definitions apply.

3.1

full back protector

FB

protective device worn on the back intended to reduce the severity of injuries caused by impacts to the central back and scapula area

3.2

central back protector

CB

protective device worn on the back intended to reduce the severity of injuries caused by impacts to central back area

3.3

lower back protector

lumbar protector

LB

protective device worn on the back intended to reduce the severity of injuries caused by impacts to the lumbar region

3.4

zone of protection

specific area of the protective device that is intended to provide protection

3.5

waist to shoulder length

length measured on the back from the waist line to the junction of the shoulder to the neck at the highest point (see Figure 1)

Note 1 to entry: The sizing system of back protectors is based on the user's waist to shoulder length, as no consistent relationship to the body height exists. The dimension is intended to be measured on the body with a tape measure.

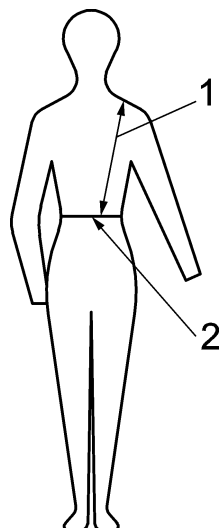

Key

- 1 waist to shoulder length
- 2 waist line

Figure 1 — Body dimensions

**3.6
 waist line**

on a subject standing upright, the line in the plane of the waist, 50 mm above the supra-crystal plane which is at the level of the highest points of the iliac crests

Note 1 to entry: The dimension of 50 mm is an example which refers to a subject of height 1,78 m; it needs to be scaled pro rata with the height of the actual subject (see following sample data):

Body height (m)	1,56	1,60	1,64	1,68	1,72	1,78	1,82	1,88	1,92	1,96
Distance above iliac crest (mm)	44	45	46	47	48	50	51	53	54	55

4 Requirements

4.1 General

Motorcyclists' back protectors shall meet an overall requirement that they are safe to use, comfortable to wear and fit for their purpose.

Back protectors shall be provided with means of restraint and/or adjustments capable to ensure that the protector is maintained in position during use. This requirement is not applicable for protectors to be inserted or incorporated into garments. Testing shall be carried out according to 5.2.

4.2 Innocuousness

The innocuousness shall comply with the requirements of EN 1621-1.

4.3 Minimum dimensions of zones of protection

Motorcyclists' back protectors shall have a minimum zone of protection related to the waist to shoulder measure of the largest user indicated by the marking. The minimum dimensions of the zone of protection shall be determined from Table 1, for the upper value of the size range (see 4.6).

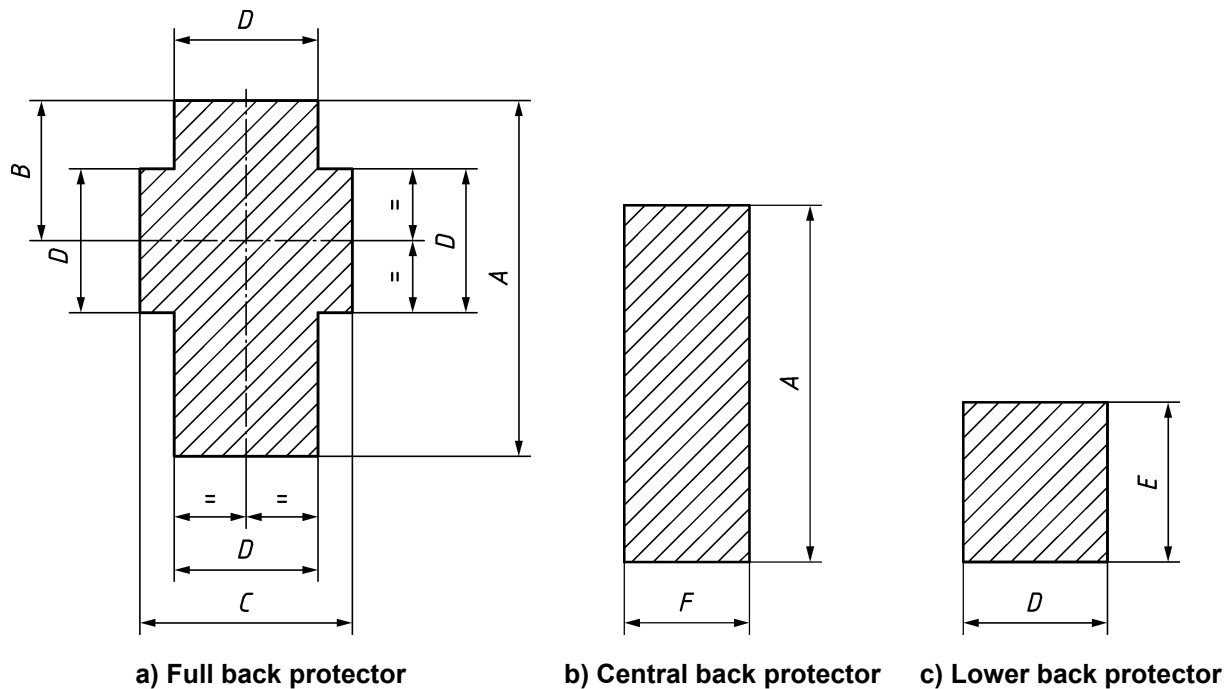

Figure 2 — Minimum dimensions of zones of protection

Table 1 — Dimensions of minimum zone of protection for back protector

Dimensions in Figure 2					
A	B	C	D	E	F
72 %	29 %	44 %	29 %	32 %	25 %
NOTE All dimensions refer to the waist to shoulder length (100 %) of the biggest user.					

The dimensions and position of the zone of protection, relative to the coverage provided by the whole product, shall be given in the information supplied by the manufacturer (see Clause 7).

NOTE The minimum dimensions of the zones of protection are usually marked on the specimens during the testing procedures.

4.4 Impact attenuation

When impact protection is tested in accordance with 5.1.6.1 (ambient impact test), 5.1.6.2 (wet impact test) and, if required, 5.1.6.3 (high temperature impact test) and/or 5.1.6.4 (low temperature impact test), the transmitted force shall conform to the values in Table 2. Level 1 or 2 cannot be awarded unless such level is achieved under all of the claimed test conditions.

Table 2 — Performance levels

Level 1	Level 2
mean value: ≤ 18 kN single strike: ≤ 24 kN	mean value: ≤ 9 kN single strike: ≤ 12 kN

After each test, there shall be no fragmentation of the sample and no sharp edges shall be formed. However, formation of cracks and loss of soft debris is permissible.

4.5 Ergonomic requirements

When examined and tested in accordance with 5.2, back protectors shall be found satisfactory for the use intended for motorcycle as indicated in the information supplied by the manufacturer. The centre line of the protective area shall be in line with the vertebra; the lower back protector shall cover the lumbar region of the back. The requirements are fulfilled if all answers to 5.2.2 are “Yes”.

4.6 Sizing and size marking

Motorcyclists' back protectors shall be marked with their sizing using a pictogram (see Figure 6) in accordance with Figure 1.

The waist to shoulder length, expressed in centimetres, shall be specified as a range up to max. 5 cm.

Testing is done according to 5.2.

5 Test methods and equipment

5.1 Impact attenuation

5.1.1 Equipment

5.1.1.1 Dropping apparatus

The apparatus shall be such that a mass (“falling weight”) can be released in order to drop along a guided vertical path onto the sample placed on a test anvil. The centre of the mass of the falling weight shall lie over the centre of the anvil.

5.1.1.2 Bar impactor

A bar impactor which shall be rectangular with a length, h_1 , equal to (160 ± 2) mm, a width, h_2 , at the top, equal to (50 ± 1) mm and with a cylindrical face with a radius, R , equal to $(12,5 \pm 0,1)$ mm shall be provided, see Figure 3. The mass of the impactor and guided mass shall be $(5\,000 \pm 50)$ g and its kinetic energy on impact shall be $(50 \pm 1,5)$ J.

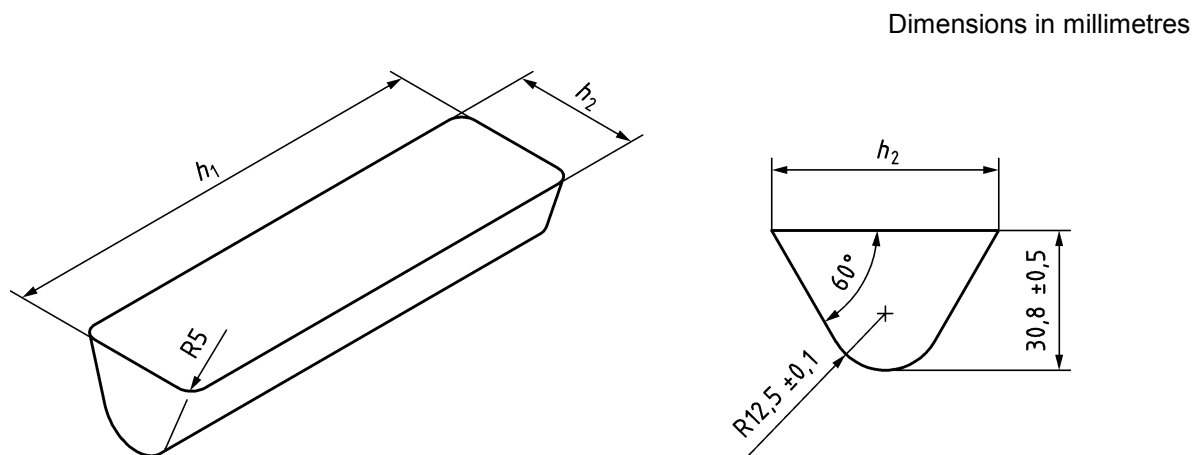
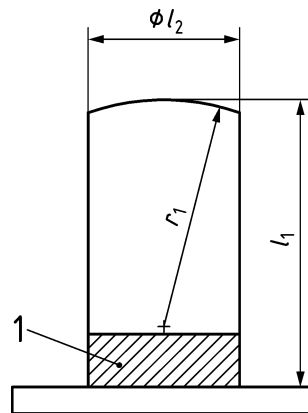

Figure 3 — Bar impactor

5.1.1.3 Anvil

The anvil shall be made of polished steel with the following dimensions l_1 equal to (190 ± 20) mm, l_2 equal to (100 ± 2) mm and r_1 equal to (150 ± 5) mm, see Figure 4.

The anvil shall be attached through a piezoelectric load cell or equivalent force transducer to a mass of at least 500 kg. The load cell or force transducer shall be preloaded to the manufacturer's instructions, if applicable.



Key

1 load cell

Figure 4 — Anvil

5.1.1.4 Force measurement instrumentation

The anvil shall be mounted so that during impact testing the whole force between the anvil and the massive base of the apparatus passes through a high speed force transducer (for instance piezoelectric quartz instruments) in line with its sensitive axis. The force transducer shall have frequency response of at least 7 kHz, a calibrated range of not less than 70 kN and a lower threshold of less than 1 kN. The output of the force transducer shall be processed by a charge amplifier and displayed and recorded on suitable instruments. The measuring system including the drop assembly shall have a frequency response in accordance with channel frequency class (CFC) 1 000 of ISO 6487.

5.1.1.5 Tolerance and uncertainty

Measuring instruments or their independent working components, unless otherwise specified, shall have an error limit of $\pm 2\%$ of the pass/fail level of the characteristic being measured.

For each of the required sequences of measurements performed in accordance with this standard a corresponding estimate of the uncertainty of the final result shall be determined. On request, this uncertainty (U_m) shall be given in the test report in the form $U_m = \pm X$. It shall be used in determining whether a "Pass" performance has been achieved. If the final result plus U_m is above the maximum Pass level, the sample shall be deemed to have failed.

5.1.2 Templates

The dimensions of the minimum zone of protection of the back protector shall comply with Table 1. Templates (see Figure 2) shall be prepared from a non-fraying (e.g. coated) fabric of a quality which basically maintains its shape and dimensions during all use. The templates shall be accurately prepared (tolerances ± 2 mm). The templates shall be used to mark the perimeter of the minimum zone of protection onto the outside of the back protector with a suitable marker. Inside such marked area, the two weakest points out of the apparently weak points, or points which appear to offer reduced protection, shall also be marked.

5.1.3 Number of samples

The number of test samples shall be:

- for ambient impact test: one sample of each size (2 samples in case of a single size product);
- for wet impact test: one sample of one size;
- for high temperature impact test (optional): one sample of one size;
- for low temperature impact test (optional): one sample of one size.

5.1.4 Number of tests

Five impacts shall be carried out on each test sample using the equipment described in 5.1.1. Three impacts shall be distributed randomly on the test area. Two impacts shall be done on visually identified weak points (if there are more than two critical points, choose the worst ones). The centres of the impacts shall be more than 50 mm apart.

5.1.5 Procedure

Back protectors, marked with the perimeter line of the minimum zone of protection and the examination marks in accordance with 5.1.2, shall be used.

When carrying out impact test, the following two conditions shall be fulfilled:

- a) at least 9 cm of the longitudinal axis of the bar impactor (see Figure 5) shall impact inside the template area;
- b) the centre point of the bar impactor shall be at least one centimetre away from the borderline of the protective area.

Where possible, whole back protectors shall be tested. The sample shall be placed onto the anvil outside surface upward. If it is necessary to reduce their size to fit within the test equipment, the sample may be cut and partially removed for testing. In this case, the cross section of the part to be tested shall maintain the original structure of the whole protector. Any other care should be taken to ensure that the cutting and removal of parts of the back protector do not affect its performance during the impact tests.

Dimensions in millimetres

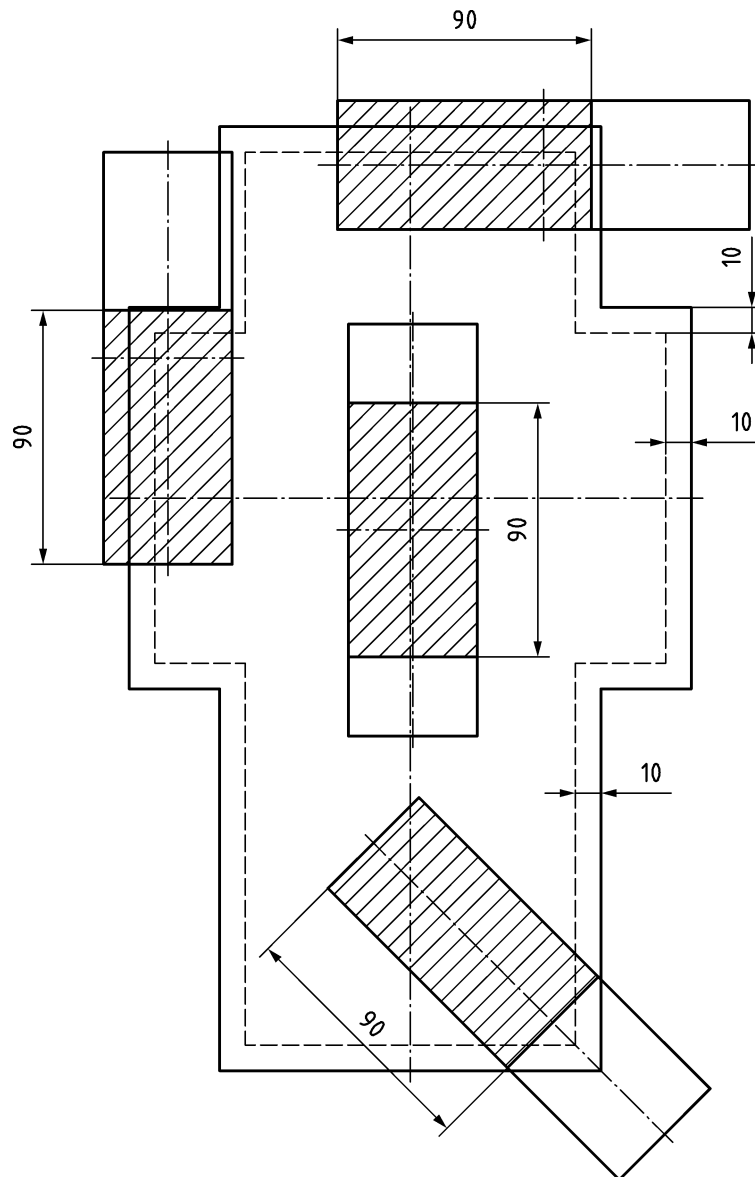

a) Example of allowed impacts

Dimensions in millimetres

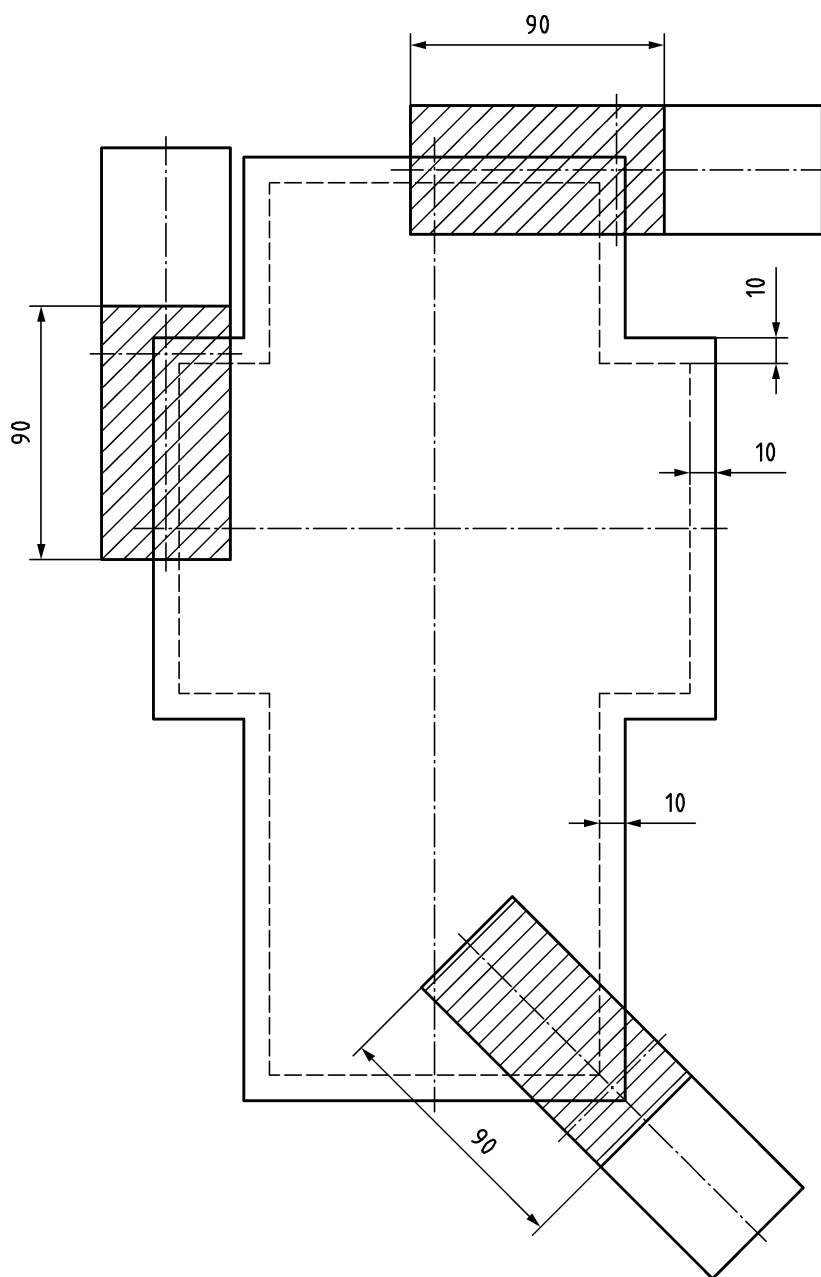

b) Example of not allowed impacts

Figure 5 — Examples of allowed and not allowed impacts

5.1.6 Tests

5.1.6.1 Ambient impact test

The samples shall be conditioned for at least 48 h in an atmosphere with a temperature of $(23 \pm 2) ^\circ\text{C}$ and a relative humidity of $(50 \pm 5) \%$. If the tests are carried out in an atmosphere different to these specified values, the tests shall be carried out within 5 min after removal from the conditioning atmosphere. If necessary, recondition the sample immediately for further 45 min to 60 min.

The number of the samples required is given in 5.1.3.

5.1.6.2 Wet impact test after hydrolytic ageing

Resistance to wet conditions after hydrolytic ageing: store the samples for $(72 \pm 0,5)$ h in a closed box above water maintained at a temperature of (70 ± 2) °C; then remove the sample, close it tightly into a water vapour proof bag and leave it in ambient temperature of (23 ± 2) °C for another $(24 \pm 0,5)$ h. After that, remove the sample from the bag and start the wet impact tests within 5 min on the previously prepared impact test machine.

The number of the samples required is given in 5.1.3.

5.1.6.3 High temperature impact test (optional)

Where the manufacturer claims protection at higher ambient temperature:

- The samples shall be conditioned for at least 24 h at (40 ± 2) °C.
- Carry out the impact testing within 2 min after removing the sample from the conditioning environment. No hit shall be performed after that period.
- If necessary, recondition the sample immediately for further 45 min to 60 min.

The number of the samples required is given in 5.1.3.

5.1.6.4 Low temperature impact test (optional)

Where the manufacturer claims protection at lower ambient temperature:

- The samples shall be conditioned for at least 24 h at (-10 ± 2) °C.
- Carry out the impact testing within 2 min after removing the sample from the freezing chamber. No hit shall be performed after that period.
- If necessary, within two more minutes start to recondition the sample for a further period of 45 min to 60 min.

The number of the samples required is given in 5.1.3.

5.2 Ergonomic assessment

5.2.1 General

One back protector per size is examined visually for the absence of any sharp edges and/or other design features that may cause problems. The protector is then put on by an assessor of suitable size with experience of riding a motorcycle, using, if applicable, the restraint elements supplied with the protector. Otherwise, suitable fastening means, such as a suitable host garment provided by the manufacturer of the protector or elastic bands or elastic socks are to be used. The correspondence between the protective area marked on the back protector and the extent of the body part to be protected shall be checked.

The assessor shall then carry out the following tests.

5.2.2 Tests

To obtain a positive result, all of the following questions need to be answered with "Yes". Check if the requirements of 4.5 are fulfilled.

- a) Can you get on and off a motorcycle?

- b) Can you comfortably reach the controls of the motorcycle?
- c) Can you turn your head and torso when on a motorcycle?
- d) While performing the movements of a), b) and c):
 - 1) Can you confirm that the adjustment system, if present, does not cause discomfort?
 - 2) Does the adjustment system, if present, securely hold the protector in place?

5.3 Expression of test results

- a) Ambient impact test: detected average and peak values and compliance with 5.1.6.1;
- b) wet impact test: detected average and peak values and compliance with 5.1.6.2;
- c) high temperature impact test (if claimed): detected average and peak values and compliance with 5.1.6.3;
- d) low temperature impact test (if claimed): detected average and peak values and compliance with 5.1.6.4;
- e) ergonomic requirements: pass or fail vote.

5.4 Test report

The test report shall include the following information:

- a) identification of the back protector(s), including source and date of receipt;
- b) the methods used by reference to this European Standard;
- c) results of the tests (see 5.3);
- d) sex and waist to shoulder length of the ergonomic assessor;
- e) if relevant, specific reasons for failure of any of the ergonomic test;
- f) any unusual features observed during the tests;
- g) date of the test report;
- h) period of the execution of the tests;
- i) identification of the laboratory carrying out the tests.

6 Marking

Motorcyclists' back protectors shall be permanently and clearly marked with at least the following information:

- a) name and/or registered trade mark of the manufacturer or his authorized representative;
- b) identification of the product type, commercial name or code;
- c) a graphical representation showing:
 - 1) the type of protector:
 - i) "FB" for full back protector;

- ii) "CB" for central back protector; or
 - iii) "LB" for lower back protector;
- 2) the performance level concerning the impact attenuation in accordance with 4.4:
- i) "T+" if the high temperature impact test is passed (if the test is not claimed, the space is vacant);
 - ii) "T-" if the low temperature impact test is passed (if the test is not claimed, the space is vacant).

A suitable graphical representation is shown in Figure 6;

- d) a graphical representation showing the size range of the protector (waist to shoulder length as described in 4.6). A suitable graphical representation is shown in Figure 6;
- e) number and year of this European Standard (EN 1621-2:2014);
- f) at the discretion of the manufacturer, the graphical symbol according to ISO 7000-1641 ("i" in a book) may be placed on the protector.

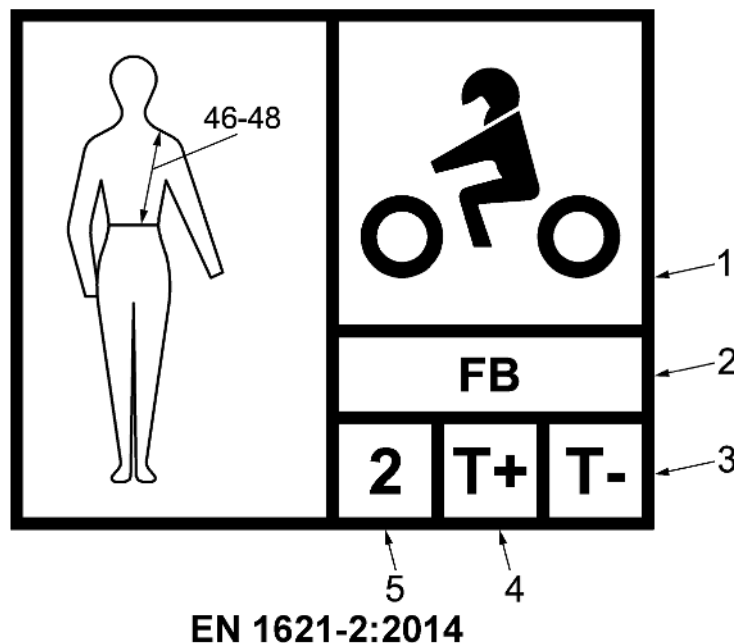

Key

- 1 protective equipment for motorcycle riders (ISO 7000-2618)
- 2 category and type of the protector
- 3 low temperature impact test passed (if the space is vacant, the test is not claimed)
- 4 high temperature impact test passed (if the space is vacant, the test is not claimed)
- 5 performance level (see 4.4)

Figure 6 — Example of marking of a protector according to Clause 6, list entries c), d) and e)

7 Information supplied by the manufacturer

Motorcyclists back protectors shall be supplied with information and instructions for fitting, use and maintenance. These are an essential part of protective equipment. They shall contain at least the following information in the official language(s) of the state or region in which they are placed on the market.

The following information shall be given:

- a) name and full address of the manufacturer and/or his authorized representative;
- b) type of use for which the protector is intended including any relevant restrictions;
- c) hazards specific to motorcycling against which some protection is given;
- d) hazards specific to motorcycling against which protection is NOT given;
- e) care instructions and/or international care symbols;
- f) product identification in accordance with above b) and c);
- g) number of the European Standard and year of publication (EN 1621-2:2014);
- h) explanation of the pictogram and other symbols used;
- i) instruction for use:
 - 1) fitting, how to put on and off, if relevant;
 - 2) performance of impact attenuation not better than as recorded during technical tests;
 - 3) limitations on use (e.g. temperature range, exchange after being exposed to an impact, ageing);
 - 4) instructions for storage and maintenance;
 - 5) instruction for cleaning;
 - 6) appropriate warning against problems which could arise from particular properties or misuse, or alteration or ageing of the protector (e.g. cutting off parts, chemical contaminations);
 - 7) if helpful illustrations, part numbers, etc. shall be added;
- j) the type of packaging suitable for transport if relevant;
- k) all the information required in Clause 6, including explanation of the elements and performance levels detailed on the marking;
- l) instruction on how to adjust the back protector and the restraint system, if applicable;
- m) a warning about any changes in environmental conditions, such as temperature, that would significantly reduce the performance of the back protector;
- n) dimensions of the zone of protection, relative to the coverage provided by the whole product;

Warning: no scapula protection in case of central back protector;

Warning: no upper back protection in case of lumbar protector;
- o) information on the selection of the correct size of the device; including the information that one single size cannot fit all body dimensions (height and shape) and a warning to avoid choosing too big of a protector because interference with helmet may occur, resulting in a dangerous riding condition:

The information of the note of Definition 3.5 may be given to the users;

- p) a warning that no back protector can offer full protection against injury;
- q) a specific warning that spinal injuries will not be prevented by the back protector;
- r) a warning about any contamination, alteration to the back protector, or misuse that would dangerously reduce the performance of the back protector;
- s) instructions for caring and cleaning the back protector;
- t) instructions concerning inspection and repair of the back protector, when to replace it and how to decide if it no longer provides adequate protection.

Annex A (informative)

Method of metrological confirmation

A.1 Method of metrological confirmation

This method aims at checking if the impact machines are properly set up and if the impacts values are reproducible using a common reference material. This method is not to be considered as a “calibration method”.

A.2 Reference material

The reference sample is made up of 5 layers of rubber, each having $5 \text{ mm} \pm 0,5 \text{ mm}$ thickness and a square shape of about $25 \text{ cm} \times 25 \text{ cm}$. The layers are kept together at their borders with suitable means (e.g. clips), in a way which does not cause tensions or deformations to the functional part of the sample.

NOTE The rubber ²⁾ is a NR-BR rubber (Natural Rubber–Butadiene Rubber) with the following basic characteristics: Hardness [Shore A] 65 ± 5 - Specific gravity [g/cm^3] 1.13 ± 0.03 - Colour Black - Tensile strength [MPa] 20 minimum - Elongation at break [%] 350 minimum - Tear strength [N/mm] 70 minimum.

The reference rubber material shall be kept in a cool, dry and dark environment in a completely closed protective cover (e.g. polyethylene bag). It shall be replaced in case of visible damage.

A.3 Preparation of the test sample

Test sample shall be conditioned at ambient temperature in accordance with 5.1.6.1.

A.4 Procedure

Apply the impact test in accordance with Clause 5.1. Adjust the falling height of the dropping mass to make sure the hit will occur at the required speed. Theoretical speed is $= \sqrt{2gh}$. Check the right position of the speed sensor: if the sensor measures the speed 2,5 cm above the impact, the theoretical speed is $\sqrt{2 \times 9,81 \times (1,02 - 0,025)} = 4,42 \text{ m/s}$. The rubber sample shall be hit in the central part; 8 impacts shall be performed.

A.5 Calculation

The average value of 8 impacts is expressed in kilo Newton and shall be $10,5 \text{ kN} \pm 1,0 \text{ kN}$.

2) Natural Rubber-Butadiene Rubber is the trade name of a product supplied by Tovo Gomma SpA Bedizzole – Brescia-Italy with the commercial name “Super antiabrasion type 1002”. This information is given for the convenience of users of this European Standard and does not constitute an endorsement by CEN of the product named. Equivalent products may be used if they can be shown to lead to the same results.

A.6 Precision

A.6.1 Interlaboratory test

Method and requirements result from a round robin test involving 8 laboratories having calibrated impact machines. Precision details of an interlaboratory test involving 8 laboratories having calibrated impact machines are summarized in Table A.1.

Table A.1 — Results of interlaboratory test to compare the different impact machines

Reference to EN	Average [kN]	Standard Deviation [kN]	Laboratory
EN 1621-2	10,31	0,06	Laboratory 1
EN 1621-2	10,43	0,14	Laboratory 2
EN 1621-2	9,31	0,20	Laboratory 4
EN 1621-2	10,33	0,13	Laboratory 5
EN 1621-2	11,85	0,13	Laboratory 6
EN 1621-2	10,56	0,25	Laboratory 8
EN 1621-2	11,34	0,12	Laboratory 9
EN 1621-2	10,13	0,15	Laboratory 10
	Total Average: 10,53 kN	Total Standard Deviation 0,77 kN	

A.6.2 Repeatability

The absolute difference between two independent single test results, obtained using the same method on identical test material in the same laboratory, by the same operator, using the same equipment within a short interval of time, in more than 95 % of cases, is not greater than ...% of the arithmetic mean of the two results.

A.6.3 Reproducibility

The absolute difference between two single test results, obtained using the same method on identical test material in different laboratories with different operators using different equipment, is not in more than 5 % of cases greater than ...% of the arithmetic mean of the two results.

Annex ZA (informative)

Relationship between this European Standard and the Essential Requirements of EU Directive 89/686/EEC

This European Standard has been prepared under a mandate given to CEN by the European Commission and the European Free Trade Association to provide a means of conforming to Essential Requirements of the New Approach Directive 89/686/EEC.

Once this standard is cited in the Official Journal of the European Union under that Directive and has been implemented as a national standard in at least one Member State, compliance with the clauses of this standard given in Table ZA.1 confers, within the limits of the scope of this standard, a presumption of conformity with the corresponding Essential Requirements of that Directive and associated EFTA regulations.

Table ZA.1 — Correspondence between this European Standard and Directive 89/686/EEC

Clause(s)/subclause(s) of this EN	Essential Requirements (ERs) of Directive 89/686/EEC, Annex II	Qualifying remarks/Notes
4.5	1.1.1 Ergonomics	
4.4	1.1.2.2. Classes of protection appropriate to different levels of risk	
4.5	1.1.2.1. Highest level of protection possible	
4.3	1.2.1 Absence of risks and other "inherent" nuisance factors	
4.2	1.2.1.1 Suitable constituent materials	
4.5	1.2.1.2 Satisfactory surface condition of all PPE parts in contact with the user	
4.5	1.2.1.3 Maximum permissible user impediment	
Clause 7	1.4 Information supplied by the manufacturer	
Clause 6	2.12 PPE bearing one or more identification or recognition marks directly or indirectly relating to health and safety	
4.4	3.1.1 Impact caused by falling or projecting objects and collision of parts of the body with obstacles	

WARNING —Other requirements and other EU Directives may be applicable to the product(s) falling within the scope of this standard.

Bibliography

- [1] EN ISO 1183-1, *Plastics - Methods for determining the density of non-cellular plastics - Part 1: Immersion method, liquid pycnometer method and titration method (ISO 1183-1)*
- [2] ISO 34 (all parts), *Rubber, vulcanized or thermoplastic - Determination of tear strength*
- [3] ISO 37, *Rubber, vulcanized or thermoplastic - Determination of tensile stress-strain properties*
- [4] ISO 1658, *Natural rubber (NR) - Evaluation procedure*
- [5] ISO 7000, *Graphical symbols for use on equipment - Registered symbols*
- [6] ISO 7619 (all parts), *Rubber, vulcanized or thermoplastic - Determination of indentation hardness*

British Standards Institution (BSI)

BSI is the national body responsible for preparing British Standards and other standards-related publications, information and services.

BSI is incorporated by Royal Charter. British Standards and other standardization products are published by BSI Standards Limited.

About us

We bring together business, industry, government, consumers, innovators and others to shape their combined experience and expertise into standards-based solutions.

The knowledge embodied in our standards has been carefully assembled in a dependable format and refined through our open consultation process. Organizations of all sizes and across all sectors choose standards to help them achieve their goals.

Information on standards

We can provide you with the knowledge that your organization needs to succeed. Find out more about British Standards by visiting our website at bsigroup.com/standards or contacting our Customer Services team or Knowledge Centre.

Buying standards

You can buy and download PDF versions of BSI publications, including British and adopted European and international standards, through our website at bsigroup.com/shop, where hard copies can also be purchased.

If you need international and foreign standards from other Standards Development Organizations, hard copies can be ordered from our Customer Services team.

Subscriptions

Our range of subscription services are designed to make using standards easier for you. For further information on our subscription products go to bsigroup.com/subscriptions.

With **British Standards Online (BSOL)** you'll have instant access to over 55,000 British and adopted European and international standards from your desktop. It's available 24/7 and is refreshed daily so you'll always be up to date.

You can keep in touch with standards developments and receive substantial discounts on the purchase price of standards, both in single copy and subscription format, by becoming a **BSI Subscribing Member**.

PLUS is an updating service exclusive to BSI Subscribing Members. You will automatically receive the latest hard copy of your standards when they're revised or replaced.

To find out more about becoming a BSI Subscribing Member and the benefits of membership, please visit bsigroup.com/shop.

With a **Multi-User Network Licence (MUNL)** you are able to host standards publications on your intranet. Licences can cover as few or as many users as you wish. With updates supplied as soon as they're available, you can be sure your documentation is current. For further information, email bsmusales@bsigroup.com.

BSI Group Headquarters

389 Chiswick High Road London W4 4AL UK

Revisions

Our British Standards and other publications are updated by amendment or revision.

We continually improve the quality of our products and services to benefit your business. If you find an inaccuracy or ambiguity within a British Standard or other BSI publication please inform the Knowledge Centre.

Copyright

All the data, software and documentation set out in all British Standards and other BSI publications are the property of and copyrighted by BSI, or some person or entity that owns copyright in the information used (such as the international standardization bodies) and has formally licensed such information to BSI for commercial publication and use. Except as permitted under the Copyright, Designs and Patents Act 1988 no extract may be reproduced, stored in a retrieval system or transmitted in any form or by any means – electronic, photocopying, recording or otherwise – without prior written permission from BSI. Details and advice can be obtained from the Copyright & Licensing Department.

Useful Contacts:

Customer Services

Tel: +44 845 086 9001

Email (orders): orders@bsigroup.com

Email (enquiries): cservices@bsigroup.com

Subscriptions

Tel: +44 845 086 9001

Email: subscriptions@bsigroup.com

Knowledge Centre

Tel: +44 20 8996 7004

Email: knowledgecentre@bsigroup.com

Copyright & Licensing

Tel: +44 20 8996 7070

Email: copyright@bsigroup.com



...making excellence a habit.™