

BS EN 1608:2013



BSI Standards Publication

# Thermal insulating products for building applications — Determination of tensile strength parallel to faces

**bsi.**

...making excellence a habit.™

**National foreword**

This British Standard is the UK implementation of EN 1608:2013. It supersedes BS EN 1608:1997 which is withdrawn.

The UK participation in its preparation was entrusted to Technical Committee B/540, Energy performance of materials components and buildings.

A list of organizations represented on this committee can be obtained on request to its secretary.

This publication does not purport to include all the necessary provisions of a contract. Users are responsible for its correct application.

© The British Standards Institution 2013. Published by BSI Standards Limited 2013

ISBN 978 0 580 78033 2

ICS 91.100.60

**Compliance with a British Standard cannot confer immunity from legal obligations.**

This British Standard was published under the authority of the Standards Policy and Strategy Committee on 30 April 2013.

**Amendments issued since publication**

Date	Text affected
------	---------------

---

EUROPEAN STANDARD

**EN 1608**

NORME EUROPÉENNE

EUROPÄISCHE NORM

March 2013

ICS 91.100.60

Supersedes EN 1608:1996

English Version

## Thermal insulating products for building applications - Determination of tensile strength parallel to faces

Produits isolants thermiques destinés aux applications du  
bâtiment - Détermination de la résistance à la traction  
parallèlement aux faces

Wärmedämmstoffe für das Bauwesen - Bestimmung der  
Zugfestigkeit in Plattenebene

This European Standard was approved by CEN on 15 December 2012.

CEN members are bound to comply with the CEN/CENELEC Internal Regulations which stipulate the conditions for giving this European Standard the status of a national standard without any alteration. Up-to-date lists and bibliographical references concerning such national standards may be obtained on application to the CEN-CENELEC Management Centre or to any CEN member.

This European Standard exists in three official versions (English, French, German). A version in any other language made by translation under the responsibility of a CEN member into its own language and notified to the CEN-CENELEC Management Centre has the same status as the official versions.

CEN members are the national standards bodies of Austria, Belgium, Bulgaria, Croatia, Cyprus, Czech Republic, Denmark, Estonia, Finland, Former Yugoslav Republic of Macedonia, France, Germany, Greece, Hungary, Iceland, Ireland, Italy, Latvia, Lithuania, Luxembourg, Malta, Netherlands, Norway, Poland, Portugal, Romania, Slovakia, Slovenia, Spain, Sweden, Switzerland, Turkey and United Kingdom.



EUROPEAN COMMITTEE FOR STANDARDIZATION  
COMITÉ EUROPÉEN DE NORMALISATION  
EUROPÄISCHES KOMITEE FÜR NORMUNG

**Management Centre: Avenue Marnix 17, B-1000 Brussels**

<b>Contents</b>		Page
	<b>Foreword</b> .....	<b>3</b>
<b>1</b>	<b>Scope</b> .....	<b>5</b>
<b>2</b>	<b>Normative references</b> .....	<b>5</b>
<b>3</b>	<b>Terms and definitions</b> .....	<b>5</b>
<b>4</b>	<b>Principle</b> .....	<b>5</b>
<b>5</b>	<b>Apparatus</b> .....	<b>5</b>
<b>6</b>	<b>Test specimens</b> .....	<b>6</b>
<b>7</b>	<b>Procedure</b> .....	<b>7</b>
<b>8</b>	<b>Calculation and expression of results</b> .....	<b>8</b>
<b>9</b>	<b>Accuracy of measurement</b> .....	<b>8</b>
<b>10</b>	<b>Test report</b> .....	<b>9</b>

## Foreword

This document (EN 1608:2013) has been prepared by Technical Committee CEN/TC 88 “Thermal insulating materials and products”, the secretariat of which is held by DIN.

This European Standard shall be given the status of a national standard, either by publication of an identical text or by endorsement, at the latest by September 2013, and conflicting national standards shall be withdrawn at the latest by September 2013.

Attention is drawn to the possibility that some of the elements of this document may be the subject of patent rights. CEN [and/or CENELEC] shall not be held responsible for identifying any or all such patent rights.

This document supersedes EN 1608:1996.

The revision of this standard contains no major changes, only minor corrections and clarifications of an editorial nature.

This European Standard is one of a series of standards which specify test methods for determining dimensions and properties of thermal insulating materials and products. It supports a series of product standards for thermal insulating materials and products which derive from the Council Directive of 21 December 1988 on the approximation of laws, regulations and administrative provisions of the Member States relating to construction products (Directive 89/106/EEC) through the consideration of the essential requirements.

This European Standard has been drafted for applications in building, but it may also be used in other areas where it is relevant.

This European test standard is one of the following group of interrelated standards on test methods for determining dimensions and properties of thermal insulation materials and products, all of which fall within the scope of CEN/TC 88:

- EN 822, *Thermal insulating products for building applications — Determination of length and width*
- EN 823, *Thermal insulating products for building applications — Determination of thickness*
- EN 824, *Thermal insulating products for building applications — Determination of squareness*
- EN 825, *Thermal insulating products for building applications — Determination of flatness*
- EN 826, *Thermal insulating products for building applications — Determination of compression behaviour*
- EN 1602, *Thermal insulating products for building applications — Determination of the apparent density*
- EN 1603, *Thermal insulating products for building applications — Determination of dimensional stability under constant normal laboratory conditions (23 °C/50 % relative humidity)*
- EN 1604, *Thermal insulating products for building applications — Determination of dimensional stability under specified temperature and humidity conditions*
- EN 1605, *Thermal insulating products for building applications — Determination of deformation under specified compressive load and temperature conditions*
- EN 1606, *Thermal insulating products for building applications — Determination of compressive creep*

- EN 1607, *Thermal insulating products for building applications — Determination of tensile strength perpendicular to faces*
- EN 1608, *Thermal insulating products for building applications — Determination of tensile strength parallel to faces*
- EN 1609, *Thermal insulating products for building applications — Determination of short-term water absorption by partial immersion*
- EN 12085, *Thermal insulating products for building applications — Determination of linear dimensions of test specimens*
- EN 12086, *Thermal insulating products for building applications — Determination of water vapour transmission properties*
- EN 12087, *Thermal insulating products for building applications — Determination of long-term water absorption by immersion*
- EN 12088, *Thermal insulating products for building applications — Determination of long-term water absorption by diffusion*
- EN 12089, *Thermal insulating products for building applications — Determination of bending behaviour*
- EN 12090, *Thermal insulating products for building applications — Determination of shear behaviour*
- EN 12091, *Thermal insulating products for building applications — Determination of freeze-thaw resistance*
- EN 12429, *Thermal insulating products for building applications — Conditioning to moisture equilibrium under specified temperature and humidity conditions*
- EN 12430, *Thermal insulating products for building applications — Determination of behaviour under point load*
- EN 12431, *Thermal insulating products for building applications — Determination of thickness for floating floor insulating products*
- EN 13793, *Thermal insulating products for building applications — Determination of behaviour under cyclic loading*
- EN 13820, *Thermal insulating materials for building applications — Determination of organic content*

According to the CEN/CENELEC Internal Regulations, the national standards organisations of the following countries are bound to implement this European Standard: Austria, Belgium, Bulgaria, Croatia, Cyprus, Czech Republic, Denmark, Estonia, Finland, Former Yugoslav Republic of Macedonia, France, Germany, Greece, Hungary, Iceland, Ireland, Italy, Latvia, Lithuania, Luxembourg, Malta, Netherlands, Norway, Poland, Portugal, Romania, Slovakia, Slovenia, Spain, Sweden, Switzerland, Turkey and the United Kingdom.

## 1 Scope

This European Standard specifies the equipment and procedures for determining the tensile strength of a product parallel to its faces. It is applicable to thermal insulating products.

This European Standard can be used to determine whether the product has sufficient strength to withstand stresses during transportation and application.

## 2 Normative references

The following documents, in whole or in part, are normatively referenced in this document and are indispensable for its application. For dated references, only the edition cited applies. For undated references, the latest edition of the referenced document (including any amendments) applies.

EN 823, *Thermal insulating products for building applications — Determination of thickness*

EN 12085, *Thermal insulating products for building applications — Determination of linear dimensions of test specimens*

ISO 5725-1, *Accuracy (trueness and precision) of measurement methods and results — Part 1: General principles and definitions*

ISO 5725-2, *Accuracy (trueness and precision) of measurement methods and results — Part 2: Basic method for the determination of repeatability and reproducibility of a standard measurement method*

## 3 Terms and definitions

For the purposes of this document, the following term and definition applies.

### 3.1

#### **tensile strength parallel to faces**

$\sigma_t$

maximum recorded tensile force parallel to the product faces during the pulling operation, divided by the cross-sectional testing area of the test specimen

## 4 Principle

A test specimen is attached to two clamps which are fastened in a tensile testing machine and pulled apart at a given speed.

The maximum tensile force is recorded and the tensile strength of the test specimen is calculated.

## 5 Apparatus

**5.1 Tensile testing machine**, appropriate for the range of force and displacement involved, capable of having a constant crosshead speed adjusted to  $(10 \pm 1)$  mm/min and capable of measuring the force to an accuracy of  $\pm 1$  %.

**5.2 Two clamps**, designed so as to avoid failure of the test specimen in the area of the clamps.

The clamps shall be positioned so that the tensile stress is uniformly distributed during the test.

An example of suitable equipment is shown in Figure 1.

Any test equipment or method which provides the same result with at least the same accuracy may be used.

## 6 Test specimens

### 6.1 Dimensions of test specimens

The thickness of the test specimens shall be the original product thickness including any skins, facings, and/or coatings. The test specimens shall be cut with the shape and with the dimensions shown in Figure 2. For small products or because of equipment limitations, the test specimen length and width shall be adjusted proportionally, but with a minimum length of 500 mm.

Other specimen shapes which provide the same result to at least the same accuracy may be used.

### 6.2 Number of test specimens

The number of test specimens shall be as specified in the relevant product standard. If the number is not specified, then at least three test specimens shall be used.

In the absence of a product standard or any other European Technical Specification, the number of test specimens may be agreed between parties.

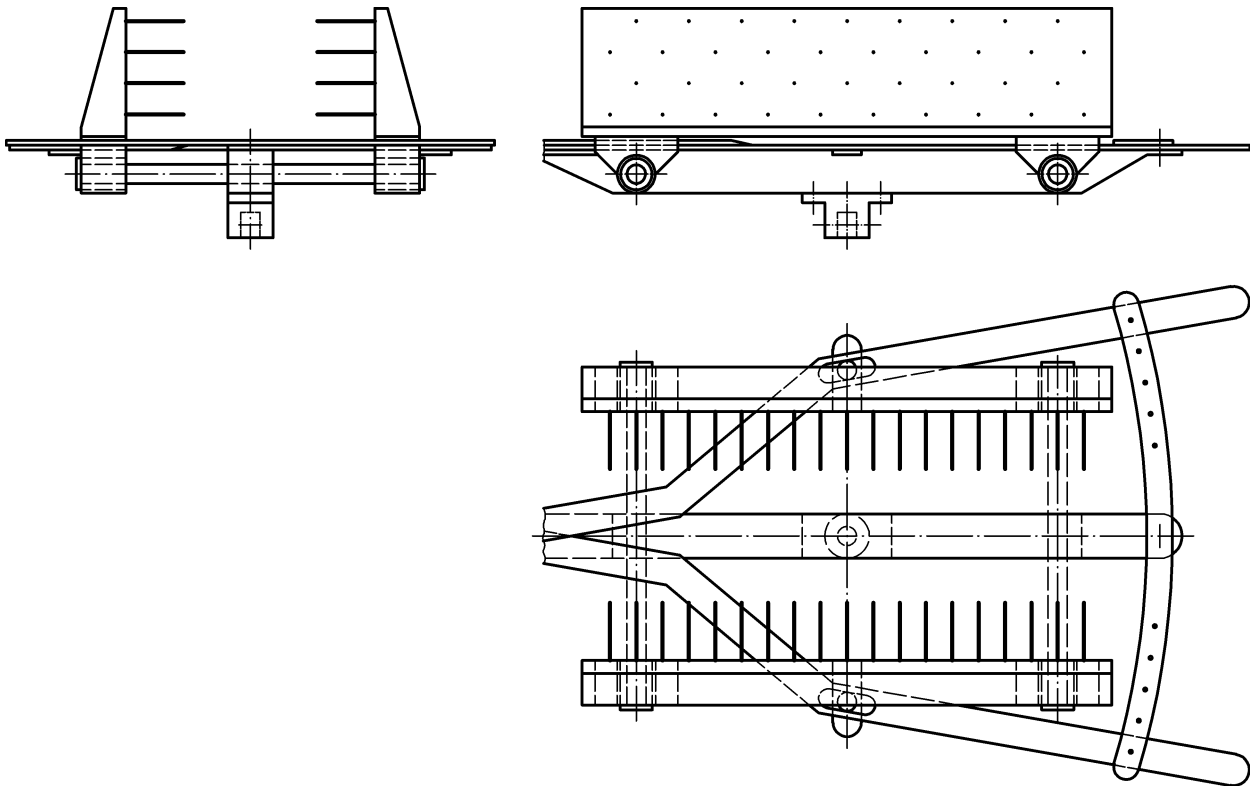

Figure 1 — Example of suitable clamps

### 6.3 Preparation of test specimens

The test specimens shall be cut from the full size product so that the length direction corresponds to the direction in which the tensile force is applied to the product in its application.



Test specimens shall be prepared by methods that do not change the original structure of the product.

Special methods of preparation, when needed, are given in the relevant product standard or any other European Technical Specification.

#### **6.4 Conditioning of test specimens**

The test specimens shall be conditioned for at least 6 h at  $(23 \pm 5)$  °C. In case of dispute, they shall be conditioned at  $(23 \pm 2)$  °C and  $(50 \pm 5)$  % relative humidity for the time stated in the relevant product standard.

### **7 Procedure**

#### **7.1 Test conditions**

Testing shall be carried out at  $(23 \pm 5)$  °C. In case of dispute, it shall be carried out at  $(23 \pm 2)$  °C and  $(50 \pm 5)$  % relative humidity.

#### **7.2 Test procedure**

Measure the thickness of the testing area,  $d$ , to the nearest millimetre, in accordance with EN 823.

Measure the length of the test specimen,  $l$ , and the width of the testing area,  $b$ , to the nearest millimetre, in accordance with EN 12085.

Attach the test specimen centrally between two clamps to distribute the stress uniformly. Place it carefully in the tensile testing machine and increase the tensile force with a constant speed of the crosshead (see 5.1) until failure occurs.

Record the maximum tensile force, in kilonewtons.

Note the way in which the product failed. Discard any test specimens that failed outside the testing area (see Figure 2).

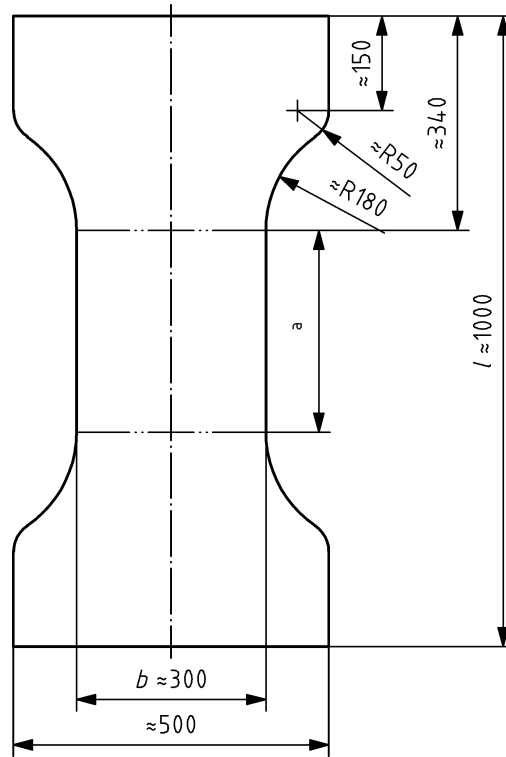

**Key**

- a length of the testing area
- b width of the testing area

**Figure 2 — Test specimen shape and dimensions**

**8 Calculation and expression of results**

Calculate the tensile strength parallel to faces,  $\sigma_t$ , in kilopascals, using the formula:

$$\sigma = \frac{F_m}{d \times b} \tag{1}$$

where

$F_m$  is the maximum tensile force recorded, in kilonewtons;

$d$  is the thickness of the testing area, in metres;

$b$  is the width of the testing area, in metres.

The result shall be expressed as the mean value from the measurements, to two significant figures.

**9 Accuracy of measurement**

Following the experience of a “round robin test”, where comparable test equipment and test specimen preparation were used, the accuracy for tensile strength,  $\sigma_t$ , can be estimated as given below.

95 % repeatability limit: approximately 3 %;

95 % reproducibility limit: approximately 10 %.

The above-mentioned terms are applied as defined in ISO 5725-1 and ISO 5725-2.

## 10 Test report

The test report shall include the following information:

- a) reference to this European Standard;
- b) product identification;
  - 1) product name, factory, manufacturer, or supplier;
  - 2) production code number;
  - 3) type of product;
  - 4) packaging;
  - 5) the form in which the product arrived at the laboratory;
  - 6) other information as appropriate (e.g. nominal dimensions, nominal density);
- c) test procedure;
  - 1) pre-test history and sampling (e.g. who sampled and place of sampling);
  - 2) conditioning;
  - 3) dimensions and number of the test specimens;
  - 4) any deviations from Clauses 6 and 7;
  - 5) date of testing;
  - 6) general information relating to the test;
  - 7) events which may have affected the results. Information about the apparatus and identity of the person responsible for the test should be available in the laboratory, but it need not be recorded in the report;
- d) results: all individual values and mean value.





# British Standards Institution (BSI)

BSI is the national body responsible for preparing British Standards and other standards-related publications, information and services.

BSI is incorporated by Royal Charter. British Standards and other standardization products are published by BSI Standards Limited.

## About us

We bring together business, industry, government, consumers, innovators and others to shape their combined experience and expertise into standards-based solutions.

The knowledge embodied in our standards has been carefully assembled in a dependable format and refined through our open consultation process. Organizations of all sizes and across all sectors choose standards to help them achieve their goals.

## Information on standards

We can provide you with the knowledge that your organization needs to succeed. Find out more about British Standards by visiting our website at [bsigroup.com/standards](http://bsigroup.com/standards) or contacting our Customer Services team or Knowledge Centre.

## Buying standards

You can buy and download PDF versions of BSI publications, including British and adopted European and international standards, through our website at [bsigroup.com/shop](http://bsigroup.com/shop), where hard copies can also be purchased.

If you need international and foreign standards from other Standards Development Organizations, hard copies can be ordered from our Customer Services team.

## Subscriptions

Our range of subscription services are designed to make using standards easier for you. For further information on our subscription products go to [bsigroup.com/subscriptions](http://bsigroup.com/subscriptions).

With **British Standards Online (BSOL)** you'll have instant access to over 55,000 British and adopted European and international standards from your desktop. It's available 24/7 and is refreshed daily so you'll always be up to date.

You can keep in touch with standards developments and receive substantial discounts on the purchase price of standards, both in single copy and subscription format, by becoming a **BSI Subscribing Member**.

**PLUS** is an updating service exclusive to BSI Subscribing Members. You will automatically receive the latest hard copy of your standards when they're revised or replaced.

To find out more about becoming a BSI Subscribing Member and the benefits of membership, please visit [bsigroup.com/shop](http://bsigroup.com/shop).

With a **Multi-User Network Licence (MUNL)** you are able to host standards publications on your intranet. Licences can cover as few or as many users as you wish. With updates supplied as soon as they're available, you can be sure your documentation is current. For further information, email [bsmusales@bsigroup.com](mailto:bsmusales@bsigroup.com).

## BSI Group Headquarters

389 Chiswick High Road London W4 4AL UK

## Revisions

Our British Standards and other publications are updated by amendment or revision.

We continually improve the quality of our products and services to benefit your business. If you find an inaccuracy or ambiguity within a British Standard or other BSI publication please inform the Knowledge Centre.

## Copyright

All the data, software and documentation set out in all British Standards and other BSI publications are the property of and copyrighted by BSI, or some person or entity that owns copyright in the information used (such as the international standardization bodies) and has formally licensed such information to BSI for commercial publication and use. Except as permitted under the Copyright, Designs and Patents Act 1988 no extract may be reproduced, stored in a retrieval system or transmitted in any form or by any means – electronic, photocopying, recording or otherwise – without prior written permission from BSI. Details and advice can be obtained from the Copyright & Licensing Department.

## Useful Contacts:

### Customer Services

**Tel:** +44 845 086 9001

**Email (orders):** [orders@bsigroup.com](mailto:orders@bsigroup.com)

**Email (enquiries):** [cservices@bsigroup.com](mailto:cservices@bsigroup.com)

### Subscriptions

**Tel:** +44 845 086 9001

**Email:** [subscriptions@bsigroup.com](mailto:subscriptions@bsigroup.com)

### Knowledge Centre

**Tel:** +44 20 8996 7004

**Email:** [knowledgecentre@bsigroup.com](mailto:knowledgecentre@bsigroup.com)

### Copyright & Licensing

**Tel:** +44 20 8996 7070

**Email:** [copyright@bsigroup.com](mailto:copyright@bsigroup.com)



...making excellence a habit.™