

BS EN 1561:2011



BSI Standards Publication

Founding — Grey cast irons

NO COPYING WITHOUT BSI PERMISSION EXCEPT AS PERMITTED BY COPYRIGHT LAW

raising standards worldwide™



National foreword

This British Standard is the UK implementation of EN 1561:2011. It supersedes BS EN 1561:1997 which is withdrawn.

The UK participation in its preparation was entrusted to Technical Committee ISE/111, Steel Castings and Forgings.

A list of organizations represented on this committee can be obtained on request to its secretary.

This publication does not purport to include all the necessary provisions of a contract. Users are responsible for its correct application.

© BSI 2011

ISBN 978 0 580 70175 7

ICS 77.080.10

Compliance with a British Standard cannot confer immunity from legal obligations.

This British Standard was published under the authority of the Standards Policy and Strategy Committee on 31 October 2011.

Amendments issued since publication

Date	Text affected
------	---------------

English Version

Founding - Grey cast irons

Fonderie - Fontes à graphite lamellaire

Gießereiwesen - Gusseisen mit Lamellengraphit

This European Standard was approved by CEN on 17 September 2011.

CEN members are bound to comply with the CEN/CENELEC Internal Regulations which stipulate the conditions for giving this European Standard the status of a national standard without any alteration. Up-to-date lists and bibliographical references concerning such national standards may be obtained on application to the CEN-CENELEC Management Centre or to any CEN member.

This European Standard exists in three official versions (English, French, German). A version in any other language made by translation under the responsibility of a CEN member into its own language and notified to the CEN-CENELEC Management Centre has the same status as the official versions.

CEN members are the national standards bodies of Austria, Belgium, Bulgaria, Croatia, Cyprus, Czech Republic, Denmark, Estonia, Finland, France, Germany, Greece, Hungary, Iceland, Ireland, Italy, Latvia, Lithuania, Luxembourg, Malta, Netherlands, Norway, Poland, Portugal, Romania, Slovakia, Slovenia, Spain, Sweden, Switzerland and United Kingdom.

EUROPEAN COMMITTEE FOR STANDARDIZATION
COMITÉ EUROPÉEN DE NORMALISATION
EUROPÄISCHES KOMITEE FÜR NORMUNG**Management Centre: Avenue Marnix 17, B-1000 Brussels**

Contents

Page

Foreword.....	3
Introduction	4
1 Scope	5
2 Normative references	5
3 Terms and definitions	5
4 Designation	6
5 Order information	6
6 Manufacture.....	7
7 Requirements	7
7.1 Characterizing properties	7
7.2 Tensile properties	7
7.3 Hardness properties.....	8
7.4 Graphite structure.....	9
8 Sampling.....	9
8.1 General.....	9
8.2 Samples for tensile test	10
8.3 Samples for hardness test.....	15
9 Test methods.....	15
9.1 Tensile test	15
9.2 Brinell hardness test	16
9.3 Graphite structure.....	16
9.4 Alternative test procedures	17
10 Retests	17
10.1 Need for retests.....	17
10.2 Test validity	17
10.3 Nonconforming test results.....	17
10.4 Heat treatment of samples and castings.....	17
11 Inspection documentation	18
Annex A (informative) Additional information on mechanical and physical properties	19
Annex B (informative) Comparison of grey cast iron material designations according to EN 1560 and ISO/TR 15931 [13]	21
Annex C (informative) Additional information on the relationship between hardness and tensile strength.....	22
Annex D (informative) Guidance values for tensile strength for test pieces machined from samples cut from a casting	24
Annex E (informative) Additional information on the relationship between tensile strength, hardness and wall thickness of grey iron castings	25
Annex F (informative) Wedge penetration test.....	28
Annex G (informative) Significant technical changes between this European standard and the previous edition	31
Bibliography.....	32

Foreword

This document (EN 1561:2011) has been prepared by Technical Committee CEN/TC 190 "Foundry technology", the secretariat of which is held by DIN.

This European Standard shall be given the status of a national standard, either by publication of an identical text or by endorsement, at the latest by April 2012, and conflicting national standards shall be withdrawn at the latest by April 2012.

Attention is drawn to the possibility that some of the elements of this document may be the subject of patent rights. CEN [and/or CENELEC] shall not be held responsible for identifying any or all such patent rights.

This document supersedes EN 1561:1997.

Within its programme of work, Technical Committee CEN/TC 190 requested CEN/TC 190/WG 5 "Grey cast iron and compacted graphite cast iron" to revise EN 1561:1997.

Annex G provides details of significant technical changes between this European Standard and the previous edition.

According to the CEN/CENELEC Internal Regulations, the national standards organizations of the following countries are bound to implement this European Standard: Austria, Belgium, Bulgaria, Croatia, Cyprus, Czech Republic, Denmark, Estonia, Finland, France, Germany, Greece, Hungary, Iceland, Ireland, Italy, Latvia, Lithuania, Luxembourg, Malta, Netherlands, Norway, Poland, Portugal, Romania, Slovakia, Slovenia, Spain, Sweden, Switzerland and the United Kingdom.

Introduction

This European Standard deals with the classification of grey cast irons, subdivided into two groups, specified by their tensile strength or hardness, respectively.

The properties of grey cast iron depend on the form and distribution of the graphite and the structure of the matrix.

In the previous edition of EN 1561, the designation by symbol was based on the minimum tensile strength to be obtained in the separately cast sample with 30 mm diameter. In Table 1 of this previous edition, the corresponding mandatory minimum tensile strength values, which should be obtained for relevant wall thicknesses up to 300 mm, in a cast-on sample were given.

For castings which have been designed before the date of issue of this standard, it is furthermore possible to determine the tensile strength of the specified grey cast iron grade by using separately cast samples with a diameter of 30 mm, irrespective of the relevant wall thickness.

In this case, the mandatory minimum values for the tensile strength, as specified in the previous edition (EN 1561:1997) of this standard, are given in Annex A, Table A.1 (bold figure in the material designation).

In this edition of EN 1561, the designation by symbol is based on the minimum tensile strength to be obtained in a cast sample, which diameter corresponds to the relevant wall thickness of the casting. This applies to a maximum relevant wall thickness of 50 mm.

Compared with the previous edition of this standard, for relevant wall thicknesses from 50 mm to 200 mm, the relationship with the 30 mm separately cast sample has been abandoned and instead of that, cast-on samples with a size corresponding to the relevant wall thickness ranges are specified. Additionally the minimum tensile properties to be obtained in these cast-on samples, are increased.

In this standard a new designation system by number, as established in EN 1560 [1], is given.

NOTE This designation system by number is based on the structure and rules of EN 10027-2 [2] and so corresponds with the European numbering system for steel and other materials.

The mechanical properties of the material can be evaluated on machined test pieces prepared from:

- separately cast samples;
- side by side cast samples;
- cast-on samples;
- samples cut from a casting.

Hardness of the material can also be evaluated on the casting.

However, for many applications tensile strength or hardness are not the only interesting or determining properties. Other mechanical or physical properties can be decisive for the use of grey cast irons, for example: thermal capacity, thermal diffusivity, damping capacity or thermo-cycle fatigue.

Therefore, Annex A (informative) provides additional information of interest to casting designers.

1 Scope

This European Standard specifies the properties of unalloyed and low-alloyed grey cast irons used for castings, which have been manufactured in sand moulds or in moulds with comparable thermal behaviour.

This European Standard specifies the characterizing properties of grey cast irons by either

- a) the tensile strength of cast samples, or
- b) the hardness measured on the castings or on a cast-on knob.

If agreed by the manufacturer and the purchaser, the combination of both tensile strength from option a) and hardness from option b) may be specified.

This European Standard specifies six grades of grey cast iron by a classification based on tensile strength measured on machined test pieces prepared from cast samples (see Table 1) and six grades of grey cast iron by a classification based on Brinell hardness (see Table 2).

This European Standard does not cover technical delivery conditions for iron castings; see EN 1559-1 [3] and EN 1559-3 [4].

This European Standard does not apply to grey cast irons used for pipes and fittings according to EN 877 [5].

2 Normative references

The following referenced documents are indispensable for the application of this document. For dated references, only the edition cited applies. For undated references, the latest edition of the referenced document (including any amendments) applies.

EN 10204, *Metallic products — Types of inspection documents*

EN ISO 945-1, *Microstructure of cast irons — Part 1: Graphite classification by visual analysis (ISO 945-1:2008)*

EN ISO 6506-1, *Metallic materials — Brinell hardness test — Part 1: Test method (ISO 6506-1:2005)*

EN ISO 6892-1, *Metallic materials — Tensile testing — Part 1: Method of test at room temperature (ISO 6892-1:2009)*

3 Terms and definitions

For the purposes of this document, the following terms and definitions apply.

3.1

grey cast iron

cast material, mainly iron and carbon based, carbon being present mainly in the form of flake (lamellar) graphite particles

NOTE 1 Grey cast iron is also known as flake graphite cast iron, and less commonly as lamellar graphite cast iron.

NOTE 2 Graphite form, distribution and size are specified in EN ISO 945-1.

3.2

cast sample

quantity of material cast to represent the cast material, including separately cast sample, side by side cast sample and cast-on sample

3.3

separately cast sample

sample cast in a separate sand mould under representative manufacturing conditions and material grade

3.4

side-by-side cast sample

sample cast in the mould alongside the casting, with a joint running system

3.5

cast-on sample

sample attached directly to the casting

3.6

relevant wall thickness

wall thickness representative of the casting, defined for the determination of the size of the cast samples to which the mechanical properties apply

4 Designation

The material shall be designated either by symbol or by number as given in either Table 1 or Table 2.

In the case of samples cut from the casting the letter C is added at the end of the designation by symbol.

NOTE Comparison of EN 1561 grade designations to the grades from the ISO standard for grey cast irons (ISO 185:2005) [6] is given in Annex B.

5 Order information

The order shall specify, in an unambiguous manner, whether the tensile strength measured on cast samples, or the Brinell hardness measured on the casting, is the characterizing property. If it does not do so, then the manufacturer shall characterize the material according to tensile strength.

The following information shall be supplied by the purchaser:

- a) the number of this European Standard;
- b) the designation of the material;
- c) the relevant wall thickness;

NOTE 1 For castings which have been designed before the date of issue of this standard, the information regarding the relevant wall thickness can be omitted.

- d) any special requirements.

All requirements shall be agreed between the manufacturer and the purchaser by the time of acceptance of the order e.g. technical delivery conditions according to EN 1559-1 and EN 1559-3.

NOTE 2 When specifying a combination of tensile strength and hardness, it is recommended to consult the information in Annex E.

In case of castings which have been designed before the date of issue of this standard, for the verification of the minimum tensile strength of the specified grey cast iron grade, separately cast samples with a diameter of 30 mm are used. The order shall specify the number and year of the previous edition (EN 1561:1997) of this European Standard.

6 Manufacture

Unless otherwise specified by the purchaser, the method of manufacture of grey cast irons to obtain the specified mechanical properties shall be left to the discretion of the manufacturer.

The manufacturer shall ensure that the requirements defined in this standard are met for the material grade specified in the order.

All agreements between the manufacturer and the purchaser shall be made by the time of acceptance of the order.

NOTE For grey cast irons to be used in special applications, the chemical composition and heat treatment may be the subject of an agreement between the manufacturer and the purchaser at the time of acceptance of the order.

7 Requirements

7.1 Characterizing properties

The order should specify in an unambiguous manner whether the tensile strength measured on a test piece machined from a cast sample or the Brinell hardness measured on the casting is the characterizing property. If it does not do so, then the manufacturer shall characterize the material according to tensile strength.

7.2 Tensile properties

7.2.1 General

The property values apply to grey cast irons cast in sand moulds or moulds of comparable thermal behaviour. Subject to amendments to be agreed upon in the order, they can apply to castings obtained by alternative methods.

Tensile properties are wall thickness dependant as shown in Table 1.

NOTE Tensile testing requires sound test pieces in order to guarantee pure uni-axial stress during the test.

7.2.2 Test pieces machined from cast samples

The tensile properties of the six grades of grey cast irons specified by tensile strength, when measured according to 9.1 using test pieces machined from cast samples according to Table 3, shall be in accordance with the requirements of Table 1. The maximum tensile strength of the grade is the minimum value plus 100 MPa.

7.2.3 Test pieces machined from samples cut from a casting

If applicable, the manufacturer and the purchaser shall agree on:

- the location(s) on a casting where the sample(s) shall be taken;
- the minimum value, or allowable range of values, for the tensile properties (for information, see Table D.1).

NOTE 1 The properties and the structure of castings are not uniform, depending on the complexity of the castings and variation in their section thickness.

NOTE 2 Tensile properties for test pieces cut from a casting are affected not only by material properties (subject of this standard) but also by the local casting soundness (not subject of this standard).

Table 1 — Tensile properties of grey cast irons measured on test pieces machined from cast samples

Material designation		Relevant wall thickness <i>t</i> mm		Tensile strength ^a <i>R_m</i> mandatory values in cast sample MPa min.
Symbol	Number	>	≤	
EN-GJL-100	5.1100	5	40	100
EN-GJL-150	5.1200	2,5 ^b	50	150
		50	100	130
		100	200	110
EN-GJL-200	5.1300	2,5 ^b	50	200
		50	100	180
		100	200	160
EN-GJL-250	5.1301	5 ^b	50	250
		50	100	220
		100	200	200
EN-GJL-300	5.1302	10 ^b	50	300
		50	100	260
		100	200	240
EN-GJL-350	5.1303	10 ^b	50	350
		50	100	310
		100	200	280

NOTE 1 The designation is irrespective of the type of cast sample.

NOTE 2 For high damping capacity and thermal conductivity, EN-GJL-100 (5.1100) is the most suitable material.

NOTE 3 The figures given in bold indicate the minimum tensile strength to which the material designation of the grade is related. The values relate to an as-cast sample diameter corresponding to the applicable relevant wall thickness range according to Table 3.

NOTE 4 For relevant wall thicknesses more than 200 mm, the manufacturer and the purchaser shall agree on the type and size of cast sample and the minimum values to be obtained.

^a If tensile strength is specified as a characterizing property, the type of the sample (see 8.2) should also be stated in the order. If not stated in the order, the type of sample is left to the discretion of the manufacturer.

^b This value is included as the lower limit of the relevant wall-thickness range.

7.3 Hardness properties

The Brinell hardness of the six grades of grey cast iron specified by hardness, when measured according to 9.2, shall be as given in Table 2. This classification is applicable principally where machinability or wear resistance are of importance.

If a casting is ordered on the basis of hardness, the relevant wall thickness and the position of the test shall be agreed.

Minimum and maximum Brinell hardness values, for the relevant wall thickness specified by the purchaser, shall be mandatory for the castings covered by the order.

NOTE For a relevant wall thickness $t > 100$ mm, grades are not classified by hardness.

If it is not possible to use the Brinell test method in accordance with EN ISO 6506-1, alternative test methods may be used, which shall have correlated values with Brinell hardness.

Table 2 — Brinell hardness of castings of grey cast irons

Material designation		Relevant wall thickness t mm		Brinell hardness ^{a, b} HBW	
Symbol	Number	>	≤	min.	max.
EN-GJL-HB155	5.1101	2,5 ^c	50	–	155
EN-GJL-HB175	5.1201	2,5 ^c	50	115	175
		50	100	105	165
EN-GJL-HB195	5.1304	5 ^c	50	135	195
		50	100	125	185
EN-GJL-HB215	5.1305	5 ^c	50	155	215
		50	100	145	205
EN-GJL-HB235	5.1306	10 ^c	50	175	235
		50	100	160	220
EN-GJL-HB255	5.1307	20 ^c	50	195	255
		50	100	180	240

NOTE 1 Information on the relationship between Brinell hardness and tensile strength is indicated in Annex C, and on the relationship between Brinell hardness and wall thickness is indicated in Annex E.

NOTE 2 The figures given in bold indicate the maximum Brinell hardness, to which the material designation of the grade is related.

^a For each grade, Brinell hardness decreases with increasing wall thickness.

^b By agreement between the manufacturer and the purchaser, a narrower hardness range may be adopted at the agreed position on the casting, provided that this is not less than 40 HBW. An example of such a circumstance could be castings for long-series production.

^c This value is included as the lower limit of the relevant wall-thickness range.

7.4 Graphite structure

If the graphite structure is agreed upon, the determination shall be carried out in accordance with 9.3.

8 Sampling

8.1 General

Samples shall be made from the same material as that used to produce the casting(s) which they represent.

Several types of samples (separately cast samples, cast-on samples, side-by-side cast samples, samples cut from a casting) can be used, depending on the mass and wall thickness of the casting.

When relevant, the type of sample should be agreed between the manufacturer and the purchaser. Unless otherwise agreed, the choice of option is left to the discretion of the manufacturer.

When the mass of the casting exceeds 1 000 kg and its thickness exceeds 50 mm, cast-on samples should preferably be used; the dimensions and the location of the sample shall be agreed between the manufacturer and the purchaser by the time of acceptance of the order.

All samples shall be adequately marked to guarantee full traceability to the castings which they represent.

The samples shall be subject to the same heat treatment, as that of the castings they represent, if any.

8.2 Samples for tensile test

8.2.1 Size of cast samples

The size of the sample shall be in correspondence with the relevant wall thickness of the casting as shown in Table 3.

If other sizes are used, this, and the minimum tensile value to be obtained, shall be agreed between the manufacturer and purchaser.

Table 3 — Types and size of cast sample and size of tensile test pieces in relation to relevant wall thickness of the casting

Relevant wall thickness t mm		Type of cast sample				Preferred diameter of tensile test piece ^a d mm
		Separately (see Figure 1)	Side by side (see Figure 1)	Cast-on Type 1 (see Figure 2)	Cast-on Type 2 (see Figure 3)	
>	≤					
–	10	I	I	b	b	10
10	20	II	II			20
20	35	III	III			32
35	50	IV	IV			32
50	100	c	c	30 mm	30 mm	20
100	200			50 mm	50 mm	32

^a Other diameters, in accordance with Table 4, may be agreed between the manufacturer and the purchaser. Unless otherwise agreed, the preferred diameter for the test piece shall be used.

^b Not to be used.

^c Diameter of cast sample, diameter of tensile test piece and minimum tensile strength to be obtained shall be agreed between manufacturer and purchaser.

Unless otherwise agreed, the choice of the type is left to the discretion of the manufacturer.

8.2.2 Frequency and number of tests

Samples representative of the material shall be produced at a frequency in accordance with the process quality assurance procedures adopted by the manufacturer or as agreed with the purchaser.

In the absence of a process quality assurance procedure or any other agreement between the manufacturer and the purchaser, a minimum of one cast sample for the tensile test shall be produced to confirm the material grade, at a frequency to be agreed between the manufacturer and the purchaser.

8.2.3 Separately cast samples

The samples shall be cast separately in sand moulds and under representative manufacturing conditions.

The moulds used to cast the separately cast samples shall have comparable thermal behaviour to the moulding material used to cast the castings. The moulds may be made for casting several samples simultaneously.

The samples shall meet the requirements of Figure 1.

The samples shall be removed from the mould at a temperature < 500 °C.

NOTE By agreement between the manufacturer and purchaser, samples may be removed from the mould at a temperature > 500 °C, if the castings are also to be removed from the moulds at this higher temperature.

Samples of other dimensions and using other casting procedures may be agreed between the manufacturer and the purchaser for the purpose of representing the properties of particular castings (an indication of the likely values of tensile strength is given in Figure E.1).

Dimensions in millimetres

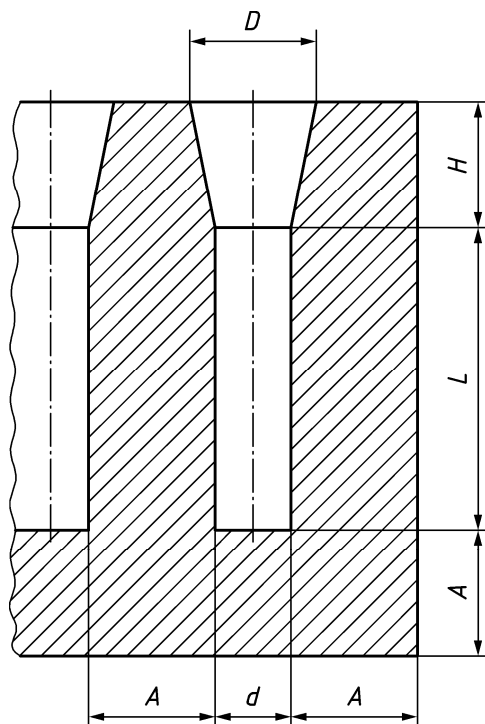

Dimension	Type			
	I	II	III	IV
$d (+2/-0)$	15	30	45	75
L^a	A function of the test piece length			
$D (+/-5)$	40	50	70	105
H	≥ 40	≥ 50	≥ 60	≥ 90
A	≥ 40	≥ 50	≥ 60	≥ 90
Preferred diameter d of tensile test piece (see Table 4)	10	20	32	32

^a L shall be chosen to allow a test piece of dimensions shown in Figure 5 to be machined from the sample

The thickness of the sand mould surrounding the samples shall be at least:

- 40 mm for types I and II;
- 80 mm for types III and IV.

Figure 1 — Separately or side-by-side cast samples

8.2.4 Side-by-side cast samples

Side-by-side cast samples are representative of the castings concurrently cast and also of all other castings of a similar relevant wall thickness from the same test unit.

When mechanical properties are required for a series of castings belonging to the same test unit, the side-by-side cast sample(s) shall be produced in the last mould(s) poured.

The samples shall meet the requirements of Figure 1 and shall be poured vertically or horizontally with an adapted feeding system.

8.2.5 Cast-on samples

Cast-on samples are representative of the castings to which they are attached and also of all other castings of a similar relevant wall thickness from the same test unit.

When mechanical properties are required for a series of castings belonging to the same test unit, the cast-on sample(s) shall be produced in the last mould(s) poured.

The sample shall have a general shape as indicated in either Figure 2 or 3 and the dimensions shown therein.

The length L shall be determined according to the length of the test piece and the clamping device.

NOTE Two possible sets of sizes are shown in Figures 2 and 3, with the larger test piece size option being shown in brackets. The small size set is used for castings less than 100 mm wall thickness and the large size set is used for castings equal to or greater than 100 mm wall thickness.

The type, dimensions and the location of the cast-on sample shall be agreed between the manufacturer and the purchaser by the time of acceptance of the order, taking into account the shape of the casting and the running system, in order to avoid any unfavourable effect on the properties of the adjacent material. If there is no such agreement, the manufacturer shall decide on the type of sample and it shall be located at a representative position on the casting.

Dimensions in millimetres

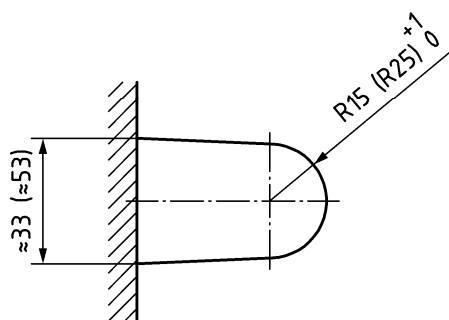
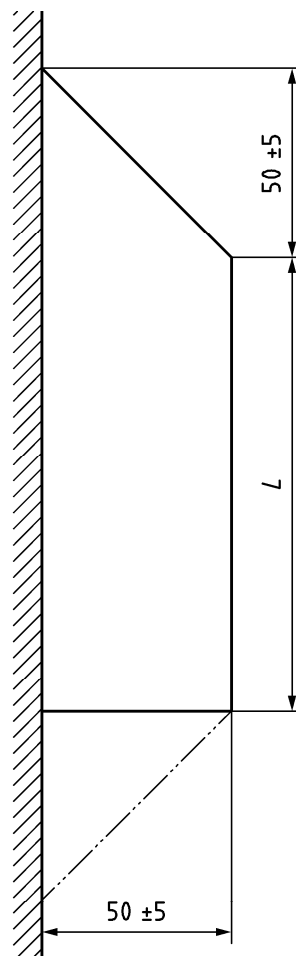
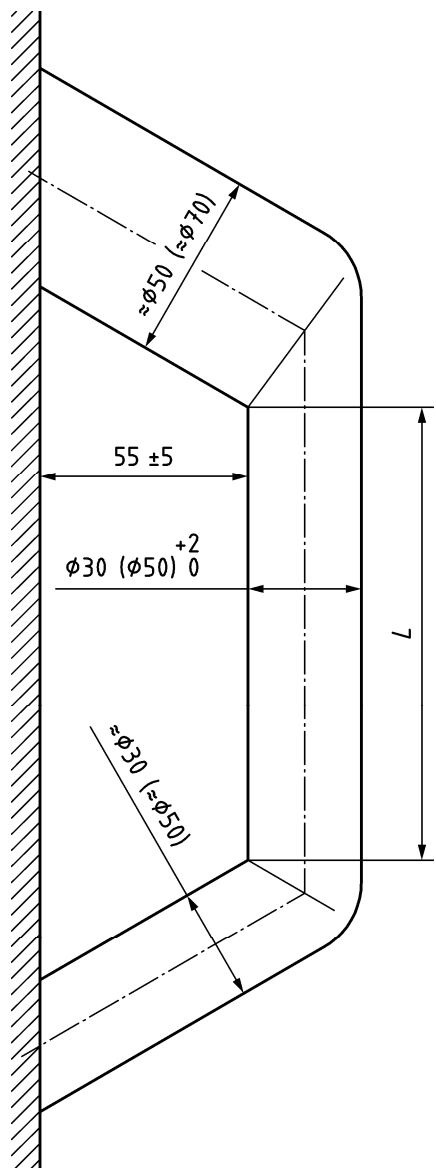

NOTE For significance of figures in brackets, see Table 3 and 8.2.5.

Figure 2 — Cast-on sample: Type 1

NOTE For significance of figures in brackets, see Table 3 and 8.2.5.

Figure 3 — Cast-on sample: Type 2

8.2.6 Samples cut from a casting

In addition to the requirements of the material, the manufacturer and the purchaser may agree on the properties required (for information, see Table D.1) at stated locations in the casting. These properties shall be determined by testing test pieces machined from samples cut from the casting at these stated locations.

The manufacturer and the purchaser shall agree on the diameter of these test pieces.

In the absence of any directions by the purchaser, the manufacturer may choose the locations from which to cut the samples and the diameter of the test pieces.

8.3 Samples for hardness test

Hardness tests may be carried out on the separately cast samples described in 8.2.

Alternatively, the Brinell hardness test may be carried out, by agreement between the manufacturer and the purchaser, on a test piece ("Brinell knob") which is cast on to the casting as shown in Figure 4. The position of the Brinell knob, and its size and shape, shall be agreed between the manufacturer and purchaser by the time of acceptance of the order.

In order to carry out the Brinell hardness test, the test piece is removed from the casting, ground on the cut surface and then tested on the ground surface.

Dimensions in millimetres

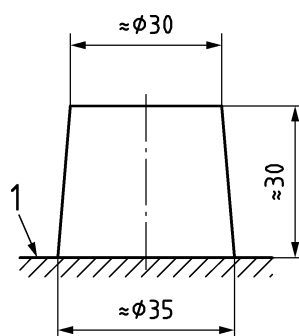

Key

- 1 surface of casting

Figure 4 — Example of a Brinell knob

If the casting is heat-treated, the Brinell knob shall not be detached from the casting until the heat-treatment process has been concluded.

9 Test methods

9.1 Tensile test

The tensile test shall be carried out in accordance with EN ISO 6892-1, using a test piece in conformance with Figure 5.

The dimensions of the test piece shall conform to the dimensions given in Table 4. The gripped parts may be for example threaded or plain to suit the clamping device.

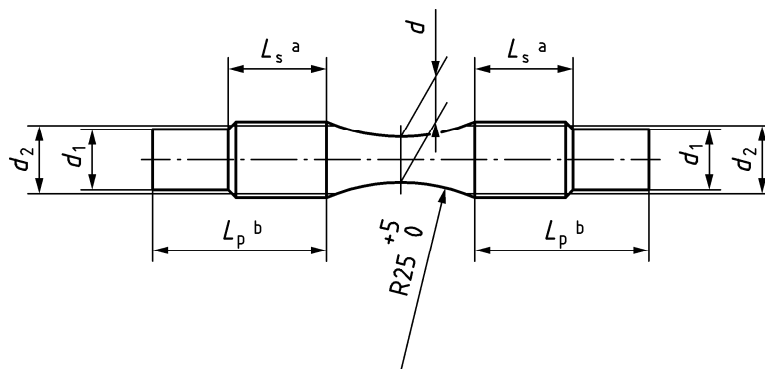

Key

- ^a threaded
- ^b plain

Figure 5 — Tensile test piece

Dimensions in millimetres

Table 4 — Dimensions of tensile test piece

Diameter <i>d</i> ^a	Thread type for threaded test piece ^b <i>d</i> ₂	Thread length <i>L</i> _s ^b	Diameter <i>d</i> ₁ for plain ends ^b	Threaded test piece total length
6 ± 0,1	M10	13	8	46
8 ± 0,1	M12	16	10	53
10 ± 0,1	M16	20	12	63
12,5 ± 0,1	M20	24	15	73
16 ± 0,1	M24	30	20	87
20 ± 0,1	M30	36	23	102
25 ± 0,1	M36	44	30	119
32 ± 0,1	M45	55	40	143

NOTE *L*_p > *L*_s, to suit clamping device.

^a The cross-sectional area *S*₀ shall be calculated.
^b Recommended dimensions

9.2 Brinell hardness test

The Brinell hardness test, if required, shall be carried out at an agreed position on the casting in accordance with the requirements of EN ISO 6506-1.

If it is not possible to use the Brinell test method in accordance with EN ISO 6506-1, alternative test methods may be used, which shall have correlated values with Brinell hardness.

9.3 Graphite structure

The graphite structure, if required, shall be determined in accordance with EN ISO 945-1.

9.4 Alternative test procedures

If agreed between the manufacturer and the purchaser, alternative test procedures, which give equivalent results for tensile strength, Brinell hardness and graphite structure, may be used.

By agreement between the manufacturer and the purchaser, the wedge penetration as described in Annex F test may be applied as an alternative to the tensile test.

10 Retests

10.1 Need for retests

Retests shall be carried out if a test is not valid (see 10.2).

Retests are permitted to be carried out if a test result does not meet the specified requirements for the specified grade (see 10.3).

10.2 Test validity

A test is not valid if there is:

- a) a faulty mounting of the test piece or defective operation of the test machine;
- b) a defective test piece because of incorrect pouring or incorrect machining;
- c) a casting defect in the test piece, evident after fracture.

In the above cases, a new test piece shall be taken from the same cast sample or from a duplicate sample cast at the same time to replace those invalid test results.

The result of the retest shall be used.

10.3 Nonconforming test results

If any test gives results which do not conform to the specified requirements, for reasons other than those given in 10.2, the manufacturer shall have the option to conduct retests.

If the manufacturer conducts retests, two retests shall be carried out for each failed test.

If both retests give results that meet the specified requirements, the material shall be deemed to conform to this European standard.

If one or both retests give results that fail to meet the specified requirements, the material shall be deemed not to conform to this European standard.

10.4 Heat treatment of samples and castings

Unless otherwise specified, in the case of castings in the as-cast condition with mechanical properties not in conformance with this European standard, a heat treatment may be carried out.

In the case of castings which have undergone a heat treatment and for which the test results are not satisfactory, the manufacturer shall be permitted to re-heat treat the castings and the representative samples. In this event, the samples shall receive the same number of heat treatments as the castings.

If the results of the tests carried out on the test pieces machined from the re-heat treated samples are satisfactory, then the re-heat treated castings shall be regarded as conforming to the specified requirements of this European Standard.

The number of re-heat treatment cycles shall not exceed two.

11 Inspection documentation

When requested by the purchaser and agreed with the manufacturer, the manufacturer shall issue for the products the appropriate inspection documentation according to EN 10204.

Annex A (informative)

Additional information on mechanical and physical properties

Information on mechanical properties is given in Table A.1. Information on physical properties is given in Table A.2. If agreed by the manufacturer and the purchaser by the time of acceptance of the order alternative test procedures may be used, for example wedge penetration test for assessment of tensile strength.

Table A.1 — Mechanical properties in cast samples with 30 mm as-cast diameter

Characteristic	Symbol	SI-unit	Material designation ^a					Bibliographical references
			EN-GJL-150 (5.1200)	EN-GJL-200 (5.1300)	EN-GJL-250 (5.1301)	EN-GJL-300 (5.1302)	EN-GJL-350 (5.1303)	
			ferritic/ pearlitic		pearlitic			
Tensile strength	R_m	MPa	150 to 250	200 to 300	250 to 350	300 to 400	350 to 450	
0,1% proof strength	$R_{p0,1}$	MPa	98 to 165	130 to 195	165 to 228	195 to 260	228 to 285	[6]
Elongation	A	%	0,8 to 0,3	0,8 to 0,3	0,8 to 0,3	0,8 to 0,3	0,8 to 0,3	[7]
Compression strength		MPa	$3,40 \times R_m$	$3,18 \times R_m$	$3,01 \times R_m$	$2,87 \times R_m$	$2,75 \times R_m$	[8]
0,1% compression proof strength		MPa	195	260	325	390	455	[6]
Bending strength		MPa	$1,82 \times R_m$	$1,73 \times R_m$	$1,66 \times R_m$	$1,60 \times R_m$	$1,54 \times R_m$	[8]
Shear strength		MPa	170	230	290	345	400	[8]
Torsional strength		MPa	$1,36 \times R_m$					[8]
Modulus of elasticity ^b	E	GPa	78 to 103	88 to 113	103 to 118	108 to 137	123 to 143	[9]
Poisson's number	ν	—	0,26	0,26	0,26	0,26	0,26	[7]
Bending fatigue strength		MPa	$0,46 \times R_m$					[8]
Fatigue limit under reversed tension-compression stresses		MPa	$0,34 \times R_m$					[8]
Torsional fatigue strength		MPa	$0,38 \times R_m$					[8]
Fracture toughness	K_{Ic}	MPa.m ^{1/2}	12	17	20	19	17	[10]
NOTE 1 MPa is equivalent to 1 N/mm ²								
^a When there are special requirements relating to machinability or magnetic properties, then EN-GJL-100 (5.1100) is used. The required properties can be obtained by means of a structure-changing heat-treatment process. EN-GJL-100 (5.1100) is not cited here.								
^b Depends on the quantity and form of the graphite as well as on the loading. The tension-elongation-curve of grey cast iron is non linear. The modulus of elasticity is the tangent line at the origin of the tension-elongation-curve.								

Table A.2 — Physical properties in cast samples with 30 mm as-cast diameter

Characteristic	Symbol	SI-unit	Material designation ^a					Bibliographical references
			EN-GJL-150 (5.1200)	EN-GJL-200 (5.1300)	EN-GJL-250 (5.1301)	EN-GJL-300 (5.1302)	EN-GJL-350 (5.1303)	
Mass density	ρ	t/m ³	7,10	7,15	7,20	7,25	7,30	–
Specific heat capacity between 20 °C and 200 °C between 20 °C and 600 °C	c	J/(kg · K)	460 535					[11]
Linear expansion coefficient between – 100 °C and + 20 °C between 20 °C and 200 °C between 20 °C and 400 °C	α	µm/(m · K)	10,0 11,7 13,0					[11]
Thermal conductivity at 100 °C at 200 °C at 300 °C at 400 °C at 500 °C	λ	W/(m · K)	52,5 51,0 50,0 49,0 48,5	50,0 49,0 48,0 47,0 46,0	48,5 47,5 46,5 45,0 44,5	47,5 46,0 45,0 44,0 43,0	45,5 44,5 43,5 42,0 41,5	[11]
Resistivity	ρ	Ω · mm ² /m	0,80	0,77	0,73	0,70	0,67	[11]
Coercivity	H_o	A/m	560 to 720					[11] [12]
Maximum permeability	μ	µH/m	220 to 330					[11] [12]
Hysteresis losses at B = 1 T		J/m ³	2 500 to 3 000					[11] [12]
^a When there are special requirements relating to machinability or magnetic properties, then EN-GJL-100 (5.1100) is used. The required properties can be obtained by means of a structure-changing heat-treatment process. EN-GJL-100 (5.1100) is not cited here.								

Annex B
(informative)

**Comparison of grey cast iron material designations according to
EN 1560 and ISO/TR 15931 [13]**

This informative annex compares the grey cast iron material designations of the standardized grades based on the ISO and EN designation systems.

Table B.1 — Material designations of grey cast irons — Classification based on mechanical properties measured on machined test pieces prepared from cast samples

EN 1561:2011 – Table 1		EN 1561:1997 –Table 1	ISO 185:2005 –Table 1
Symbol	Number	Number	Designation
EN-GJL-100	5.1100	EN-JL1010	ISO185/JL/100
EN-GJL-150	5.1200	EN-JL1020	ISO185/JL/150
EN-GJL-200	5.1300	EN-JL1030	ISO185/JL/200
EN-GJL-250	5.1301	EN-JL1040	ISO185/JL/250
EN-GJL-300	5.1302	EN-JL1050	ISO185/JL/300
EN-GJL-350	5.1303	EN-JL1060	ISO185/JL/350

Table B.2 — Material designations of grey cast irons - Classification based on hardness

EN 1561:2011 – Table 1		EN 1561:1997 –Table 1	ISO 185:2005 –Table 1
Symbol	Number	Number	Designation
EN-GJL-HB155	5.1101	EN-JL2010	ISO185/JL/HBW/155
EN-GJL-HB175	5.1201	EN-JL2020	ISO185/JL/HBW/175
EN-GJL-HB195	5.1304	EN-JL2030	ISO185/JL/HBW/195
EN-GJL-HB215	5.1305	EN-JL2040	ISO185/JL/HBW/215
EN-GJL-HB235	5.1306	EN-JL2050	ISO185/JL/HBW/235
EN-GJL-HB255	5.1307	EN-JL2060	ISO185/JL/HBW/255

Annex C (informative)

Additional information on the relationship between hardness and tensile strength

C.1 Introduction

Hardness and tensile strength as well as modulus of elasticity and the modulus of rigidity of grey cast iron of a given grade, are approximately related to each other. In most cases, an increase in the value of one property results in an increase in the values of other properties [13] to [15]. Grey cast irons naturally divide into a family or series of grades having different relative hardness (RH).

C.2 Relative hardness

The following empirical relationship between Brinell hardness (HBW) and tensile strength exists:

$$HBW = RH \times (A + B \times R_m) \quad (C.1)$$

where

- A is constant;
- B is constant;
- R_m is the tensile strength;
- RH is the relative hardness.

Commonly accepted values for the constants are:

$$A = 100$$
$$B = 0,44 [15]$$

RH has been found to vary between 0,8 and 1,2 (see Figure C.1).

Because of the variation in relative hardness it is difficult to give definitive limits in a standard for both tensile strength and hardness. More details concerning RH are discussed in literature [16] to [23].

The factor RH is influenced mainly by the raw materials, the melting process and the metallurgical working method. Within one foundry these influences can be maintained nearly constant. The manufacturer can therefore indicate both hardness and the corresponding tensile strength.

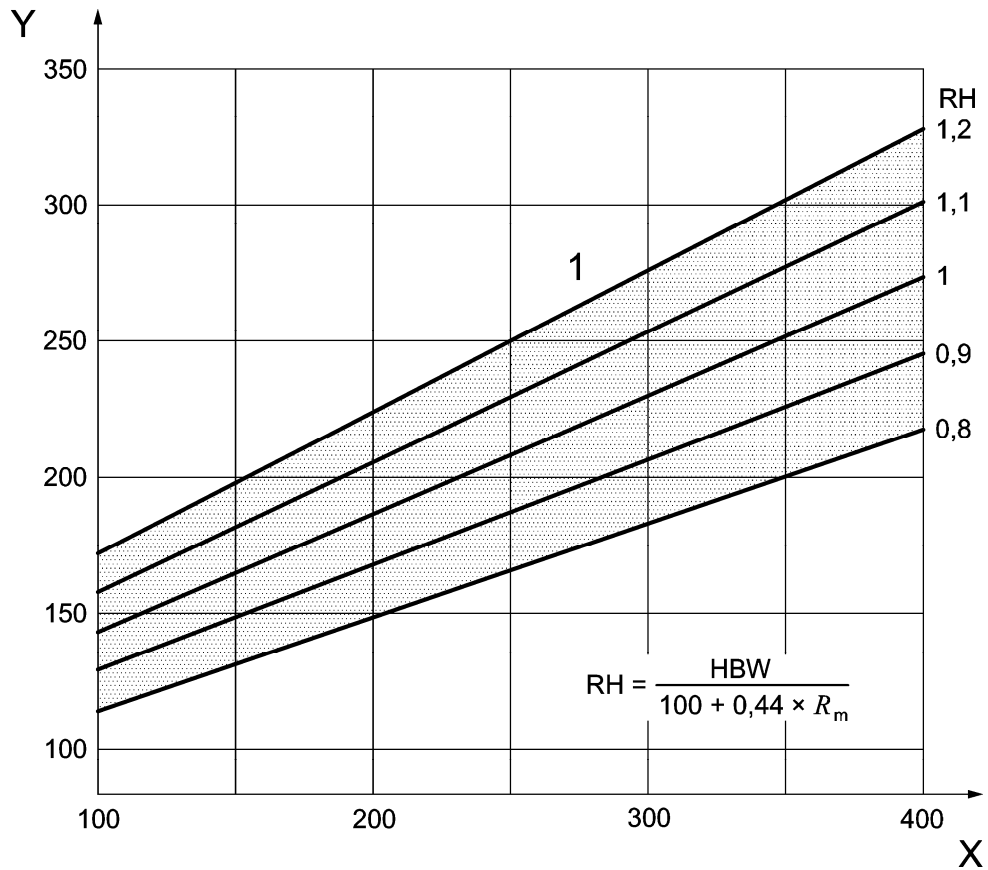

Key

- Y Brinell hardness, HBW
- X Tensile strength R_m , MPa
- 1 Relative hardness, RH

Figure C.1 — Relative hardness (RH) relationship between Brinell hardness and tensile strength of grey cast irons

Annex D (informative)

Guidance values for tensile strength for test pieces machined from samples cut from a casting

Table D.1 — Guidance values for tensile strength for test pieces machined from samples cut from a casting

Material designation		Relevant wall thickness		Tensile strength ^a R_m anticipated values in casting MPa min.
		t mm		
Symbol	Number	>	≤	
EN-GJL-150C	5.1200	2,5 ^b	50	135
		50	100	120
		100	200	110
EN-GJL-200C	5.1300	2,5 ^b	50	180
		50	100	160
		100	200	145
EN-GJL-250C	5.1301	5 ^b	50	225
		50	100	200
		100	200	185
EN-GJL-300C	5.1302	10 ^b	50	270
		50	100	245
		100	200	220
EN-GJL-350C	5.1303	10 ^b	50	320
		50	100	290
		100	200	260
<p>NOTE 1 For relevant wall thicknesses more than 200 mm, the manufacturer and the purchaser shall agree on the type and size of cast sample and the minimum values to be obtained.</p> <p>NOTE 2 When the purchaser requires minimum mechanical property values to be obtained in a stated location of the casting, these values are to be agreed with the manufacturer.</p>				
<p>^a This column gives guidance values only about the likely variation in tensile strength for different casting wall thicknesses when a casting of simple shape and uniform wall thickness is cast in a given grey cast iron material. For castings of non-uniform wall thickness, or castings containing cored holes, the table values are only an approximate guide to the likely tensile strength in different sections, and casting design should be based on the measured tensile strength in critical parts of the casting.</p> <p>^b This value is included as the lower limit of the relevant wall-thickness range.</p>				

Annex E (informative)

Additional information on the relationship between tensile strength, hardness and wall thickness of grey iron castings

Figure E.1 provides additional general information on the expected relationship between minimum tensile strength and wall thickness. Figure E.2 provides information on average Brinell hardness and wall thickness of castings.

Not all castings can be produced in any material hardness grade given in Table 2 for any wall thickness, and this is reflected in Figure E.2. To meet the requirements of any hardness range, more than one material grade can be used, depending on the wall thickness involved.

This illustrates the importance of reaching an agreement between the manufacturer and the purchaser on the specification of the hardness required in castings and also the location where a hardness test should be carried out.

EXAMPLE A For a casting with a relevant wall thickness of 40 mm grade EN-GJL-300 is selected. For this section of the casting a guidance value for the minimum tensile strength of 270 MPa is specified. (see Table D.1). For the same casting in a 10 mm section, a minimum tensile strength of 346 MPa; and in a 80 mm section, a minimum tensile strength of 238 MPa can be expected (see Figure E.1).

EXAMPLE B For a casting with a relevant wall thickness of 120 mm grade EN-GJL-300 is selected. For this section of the casting a guidance value for the minimum tensile strength of 220 MPa is specified. (see Table D.1). For the same casting in a 80 mm section, a minimum tensile strength of 250 MPa; and in a 200 mm section, a minimum tensile strength of 212 MPa can be expected (see Figure E.1).

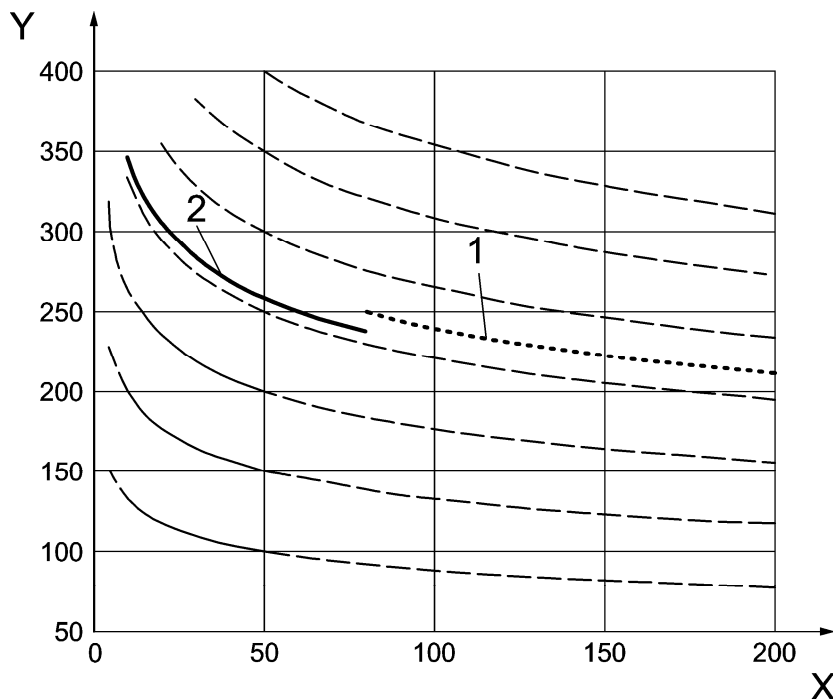

Key

- Y Tensile strength R_m , MPa
- X Wall thickness, mm
- 1 See example B
- 2 See example A

Figure E.1 — Relationship between minimum values of the tensile strength and the wall thickness of simple shaped castings

EXAMPLE C For a casting with a relevant wall thickness of 40 mm grade EN-GJL-HB195 is selected. For this section of the casting an average hardness of 165 HBW is specified. (see Table 2). For the same casting in a 10 mm section, an average hardness of 197 HBW; and in a 80 mm section, an average hardness of 150 HBW can be expected (see Figure E.2).

EXAMPLE D For a casting with a relevant wall thickness of 120 mm grade EN-GJL-HB195 is selected. For this section of the casting an average hardness of 150 HBW is specified. (see Table 2). For the same casting in a 40 mm section, an average hardness of 173 HBW; and in a 160 mm section, an average hardness of 145 HBW can be expected (see Figure E.2).

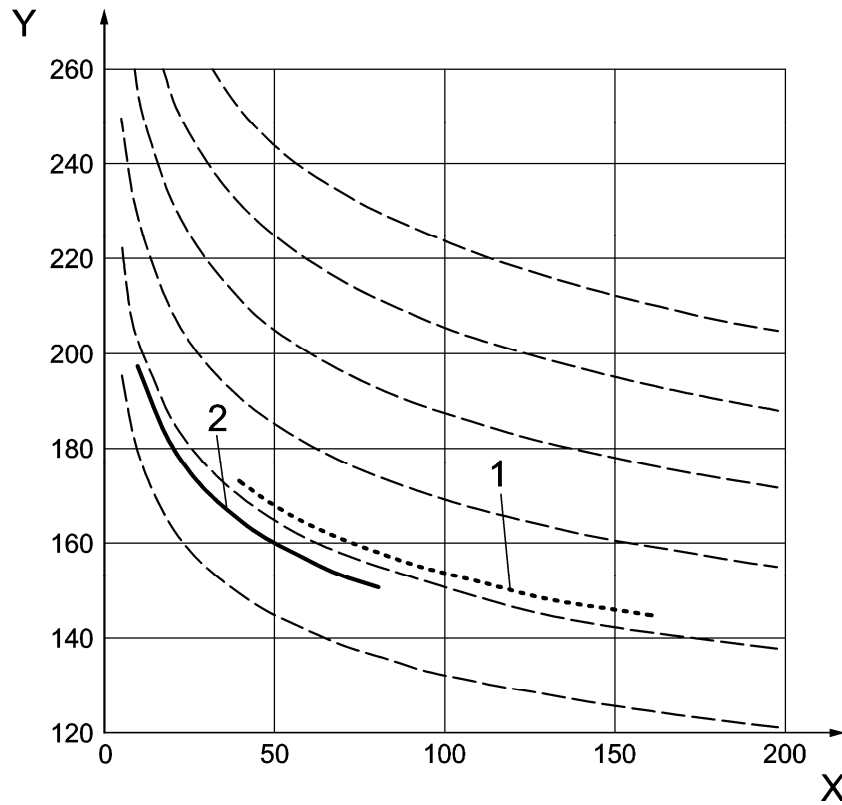

Key

- Y Brinell hardness HB 30
- X Wall thickness, mm
- 1 See example D
- 2 See example C

Figure E.2 — Relationship between average values of the Brinell hardness and the wall thickness of simple shaped castings

Annex F (informative)

Wedge penetration test

F.1 General

This informative annex specifies the method for wedge penetration testing [25] of grey cast irons as an alternative test method for tensile strength.

F.2 Principle

The test involves straining a test piece to the penetration of two sharp opposed and parallel wedges, resulting in orthogonal tensile stresses in the test piece to fracture, as shown in Figure F.1.



Figure F.1 — Principle of wedge penetration test

F.3 Symbols

Symbols used in this Annex are listed in Table F.1.

Table F.1 — Symbols

Symbol	Designation	Unit
d_0	Width or diameter of test piece	mm
D_1	Length of the fracture	mm
t	Thickness of test piece	mm
F_m	Maximum force	N
R_{mW}	Wedge penetration strength	MPa
R_m	Tensile strength	MPa
k	Correction factor for thickness	MPa

F.4 Testing apparatus

F.4.1 General

Standard tensile testing machines equipped with a wedge penetration testing device, or a dedicated wedge penetration testing machine can be used.

An example of a wedge penetration testing device is show in [25].

F.4.2 Accuracy of testing apparatus

The force-measuring system of the testing machine should be calibrated in accordance with EN ISO 7500-1 [26] and should be at least of class 1.

F.4.3 Wedges

The tolerance on the parallelism of the wedges, for a wedge length of 40 mm, should be maximum 0,1 mm, both horizontal and perpendicular.

In general, the wedge angle is $90^{\circ} \pm 30'$ and the radius at the tip of the wedge 0,15 mm to 0,20 mm.

Wedges are normally produced from quenched and tempered steel with a hardness of (740 ± 40) HV $[(62 \pm 2)$ HRC].

NOTE Dependent on the wedge angle and radius, for comparable test pieces, different values for wedge penetration strength will be obtained.

F.5 Test piece

The wedge penetration test can be performed on test pieces machined from samples cut from a casting or machined from cast samples.

The wedge penetration test enables the testing of the strength of a component even with thin wall thicknesses.

However, results can only be compared if the dimensions of the test pieces are identical.

It is recommended to use a test piece with dimensions in conformance with Table F.2.

Table F.2 — Wedge penetration test piece

Width ^a or diameter (<i>d</i>)	20,0 mm ± 0,1 mm
Thickness (<i>t</i>)	6,0 mm ± 0,1 mm
Tolerance on parallelism of thickness ^b	≤ 0,1 mm
Surface roughness ^c	$R_z \leq 25 \mu\text{m}$
<p>^a The length is minimum 20 mm; for multiple testing longer test pieces may be used.</p> <p>^b Thickness and parallelism effects the results considerably, therefore it is important to respect the required tolerances in order to guarantee parallel stress introduction.</p> <p>^c Corresponds approximately with roughness levels 1S1, A1 or 2S2 according to EN 1370 [27]</p>	

F.6 Procedure

- For each cast sample or casting at least 3 tests should be performed.
- The test should be carried out at ambient temperature between 10 °C and 35 °C, unless otherwise specified.
- The stress rate should be between 2 MPa/s and 10 MPa/s.
- When multiple testing a long test piece, the distance between each test should be at least 10 mm.

F.7 Evaluation

For each test, the wedge penetration strength is to be calculated as follows:

$$R_{mW} = F_m / (t \times d_1) \quad \text{in MPa} \quad (\text{F.1})$$

From the individual results, the average wedge penetration strength is to be calculated and in the report the number of tests is to be stated.

F.8 Correlation of wedge penetration strength with tensile strength

The tensile strength R_m correlates with the wedge penetration strength R_{mW} according the general linear equation:

$$R_m = a R_{mW} - b \quad \text{in MPa} \quad (\text{F.2})$$

where

a is constant;

b is constant.

The regression coefficients mainly depends on test piece geometry, wedge angle, wedge radius and production conditions.

Therefore, it is necessary to establish manufacturer specific equations.

Additional information can be found in [25].

Annex G (informative)

Significant technical changes between this European standard and the previous edition

Table G.1 — Significant technical changes between this European Standard and the previous edition

Clause/Paragraph/Table/Figure	Change
Introduction	explanation regarding the combination of relevant wall thickness and tensile strength, and the new system for designation of cast irons by numbers.
7.2.2, Table 1	required minimum mechanical properties applies to several types of cast samples and are given for 3 ranges of relevant wall thickness, ≤ 50 mm, 50 mm to 100 mm and 100 mm to 200 mm
7.2.2, Table 1	required minimum tensile strength to be obtained in cast sample increased for relevant wall thickness > 50 mm
7.3, Table 2	mandatory Brinell hardness values are now given for 2 ranges of relevant wall thickness, ≤ 50 mm and 50 mm to 100 mm
8.2.1, Table 3	size and type of required cast sample in relation to relevant wall thickness introduced
Annex B	informative annex added for the comparison of grey cast iron material designations according to EN 1560 and ISO/TR 15931
Annex D	anticipated values of tensile strength in casting increased for relevant wall thickness > 50 mm
Annex E	Insertion of examples to explain the relationship between wall thickness and mechanical properties
Annex F	informative annex added which describes the wedge penetration test
NOTE The technical changes referred include the significant technical changes from the EN revised but is not an exhaustive list of all modifications from the previous version.	

Bibliography

- [1] EN 1560, *Founding — Designation system for cast iron — Material symbols and material numbers*
- [2] EN 10027-2, *Designation system for steels — Part 2: Numerical system*
- [3] EN 1559-1, *Founding — Technical conditions of delivery — Part 1: General*
- [4] EN 1559-3, *Founding — Technical conditions of delivery — Part 3: Additional requirements for iron castings*
- [5] EN 877, *Cast iron pipe and, fittings, their joints and accessories for the evacuation of water from buildings — Requirements, test methods and quality assurance*
- [6] ISO 185:2005, *Grey cast irons — Classification*
- [7] *Nechtelberger, E.: Österreichisches Giesserei-Institut. Report A-No, 18 670. Leoben 1973*
- [8] *Klubberg F, Beiss, P., Broeckmann, C.: Schwingfestigkeit von Gusseisen mit Lamellengraphit. Giesserei-Praxis 60 (2009) 5, S. 153-158*
- [9] *Engineering data on grey cast irons — SI units. G. N. J. Gilbert. 2nd rev. ed. publ. British Cast Iron Research Association. Alvechurch/Birmingham 1977*
- [10] *Speidel, M. O.: Z. Werkstofftechn. 12 (1981) No. 11, p. 387–402*
- [11] *Angus, H. T.: Cast iron — Physical and engineering properties. 2nd ed. London: Butterworths 1976*
- [12] *Dietrich, H.: Giesserei, technisch-wissenschaftliche Beihefte, 14 (1962) No. 2, p. 79–91*
- [13] ISO/TR 15931, *Designation system for cast irons and pig irons*
- [14] *Collaud, A.: Giesserei, technisch-wissenschaftliche Beihefte, 6 (1954) No. 14, p. 709–726; (1955) No. 15, p. 767–799*
- [15] *Sy, A. de; Eeghem, J. van: Giesserei 47 (1960) No. 12, p. 315–323*
- [16] *Weis, W.; Orths, K.: 34. Internationaler Giessereikongress. Paris 1967. Report No. 11; see also Giessereiforschung 21 (1969) No. 3, p. 113–124*
- [17] *Mackenzie, J. T.: Foundry 74 (1946) No. 10, p. 88–93, 191, 194*
- [18] *Patterson, W.: Giesserei 45 (1958) No. 14, p. 385–387*
- [19] *Patterson, W.; Döpp, R.: Giesserei 47 (1960) No. 7, p. 175–180*
- [20] *Patterson, W.; Döpp, R.: Giesserei 60 (1973) No. 2, p. 32–39*
- [21] *Döpp, R.: Giesserei 66 (1979) No. 2, p. 40–43*
- [22] *Bauer, W.; Nechtelberger, E.: 55. International Foundry Congress Moskva 1988. Moskva 1988; see also Giesserei-Rundschau 35 (1988) No. 11/12, p. 10–15*
- [23] *Motz, J. M.: Giesserei 69 (1982) No. 18, p. 485–492*
- [24] *Motz, J. M.: Giesserei 74 (1987) No. 7, p. 214–221*

- [25] BDG-Richtlinie (VDG-Merkblatt) P340, *Wedge penetration test — Grey cast iron and compacted graphite cast iron*
- [26] EN ISO 7500-1, *Metallic materials — Verification of static uniaxial testing machines — Part 1: Tension/compression testing machines — Verification and calibration of force measuring (ISO 7500-1:2004)*
- [27] EN 1370, *Founding — Examination of surface condition*

British Standards Institution (BSI)

BSI is the independent national body responsible for preparing British Standards and other standards-related publications, information and services.

It presents the UK view on standards in Europe and at the international level.

It is incorporated by Royal Charter.

Revisions

British Standards are updated by amendment or revision. Users of British Standards should make sure that they possess the latest amendments or editions.

It is the constant aim of BSI to improve the quality of our products and services. We would be grateful if anyone finding an inaccuracy or ambiguity while using this British Standard would inform the Secretary of the technical committee responsible, the identity of which can be found on the inside front cover.

Tel: +44 (0)20 8996 9001 Fax: +44 (0)20 8996 7001

BSI offers Members an individual updating service called PLUS which ensures that subscribers automatically receive the latest editions of standards.

Tel: +44 (0)20 8996 7669 Fax: +44 (0)20 8996 7001

Email: plus@bsigroup.com

Buying standards

You may buy PDF and hard copy versions of standards directly using a credit card from the BSI Shop on the website www.bsigroup.com/shop. In addition all orders for BSI, international and foreign standards publications can be addressed to BSI Customer Services.

Tel: +44 (0)20 8996 9001 Fax: +44 (0)20 8996 7001

Email: orders@bsigroup.com

In response to orders for international standards, it is BSI policy to supply the BSI implementation of those that have been published as British Standards, unless otherwise requested.

Information on standards

BSI provides a wide range of information on national, European and international standards through its Knowledge Centre.

Tel: +44 (0)20 8996 7004 Fax: +44 (0)20 8996 7005

Email: knowledgecentre@bsigroup.com

Various BSI electronic information services are also available which give details on all its products and services.

Tel: +44 (0)20 8996 7111 Fax: +44 (0)20 8996 7048

Email: info@bsigroup.com

BSI Subscribing Members are kept up to date with standards developments and receive substantial discounts on the purchase price of standards. For details of these and other benefits contact Membership Administration.

Tel: +44 (0)20 8996 7002 Fax: +44 (0)20 8996 7001

Email: membership@bsigroup.com

Information regarding online access to British Standards via British Standards Online can be found at www.bsigroup.com/BSOL

Further information about BSI is available on the BSI website at www.bsigroup.com/standards

Copyright

Copyright subsists in all BSI publications. BSI also holds the copyright, in the UK, of the publications of the international standardization bodies. Except as permitted under the Copyright, Designs and Patents Act 1988 no extract may be reproduced, stored in a retrieval system or transmitted in any form or by any means – electronic, photocopying, recording or otherwise – without prior written permission from BSI. This does not preclude the free use, in the course of implementing the standard of necessary details such as symbols, and size, type or grade designations. If these details are to be used for any other purpose than implementation then the prior written permission of BSI must be obtained. Details and advice can be obtained from the Copyright & Licensing Manager.

Tel: +44 (0)20 8996 7070

Email: copyright@bsigroup.com

BSI Group Headquarters

389 Chiswick High Road London W4 4AL UK

Tel +44 (0)20 8996 9001

Fax +44 (0)20 8996 7001

www.bsigroup.com/standards