

**BS EN 1467:2012**



**BSI Standards Publication**

# **Natural stone — Rough blocks — Requirements**

**bsi.**

...making excellence a habit.™

**National foreword**

This British Standard is the UK implementation of EN 1467:2012. It supersedes BS EN 1467:2003 which is withdrawn.

The UK participation in its preparation was entrusted to Technical Committee B/545, Natural stone.

A list of organizations represented on this committee can be obtained on request to its secretary.

This publication does not purport to include all the necessary provisions of a contract. Users are responsible for its correct application.

© The British Standards Institution 2012. Published by BSI Standards Limited 2012

ISBN 978 0 580 75816 4

ICS 73.020; 91.100.15

**Compliance with a British Standard cannot confer immunity from legal obligations.**

This British Standard was published under the authority of the Standards Policy and Strategy Committee on 31 May 2012.

**Amendments issued since publication**

Date	Text affected
------	---------------

---

English Version

**Natural stone - Rough blocks - Requirements**

Pierres naturelles - Blocs bruts - Exigences

Natursteine - Rohblöcke - Anforderungen

This European Standard was approved by CEN on 9 March 2012.

CEN members are bound to comply with the CEN/CENELEC Internal Regulations which stipulate the conditions for giving this European Standard the status of a national standard without any alteration. Up-to-date lists and bibliographical references concerning such national standards may be obtained on application to the CEN-CENELEC Management Centre or to any CEN member.

This European Standard exists in three official versions (English, French, German). A version in any other language made by translation under the responsibility of a CEN member into its own language and notified to the CEN-CENELEC Management Centre has the same status as the official versions.

CEN members are the national standards bodies of Austria, Belgium, Bulgaria, Croatia, Cyprus, Czech Republic, Denmark, Estonia, Finland, France, Germany, Greece, Hungary, Iceland, Ireland, Italy, Latvia, Lithuania, Luxembourg, Malta, Netherlands, Norway, Poland, Portugal, Romania, Slovakia, Slovenia, Spain, Sweden, Switzerland, Turkey and United Kingdom.

EUROPEAN COMMITTEE FOR STANDARDIZATION  
COMITÉ EUROPÉEN DE NORMALISATION  
EUROPÄISCHES KOMITEE FÜR NORMUNG**Management Centre: Avenue Marnix 17, B-1000 Brussels**

## Contents

Page

Foreword.....	3
<b>1</b> <b>Scope</b> .....	<b>5</b>
<b>2</b> <b>Normative references</b> .....	<b>5</b>
<b>3</b> <b>Terms and definitions</b> .....	<b>5</b>
<b>4</b> <b>Requirements</b> .....	<b>7</b>
<b>4.1</b> <b>Requirements for geometric characteristics</b> .....	<b>7</b>
<b>4.1.1</b> <b>Measurement criteria</b> .....	<b>7</b>
<b>4.1.2</b> <b>Requirements on shape</b> .....	<b>8</b>
<b>4.1.3</b> <b>Requirements for volume</b> .....	<b>8</b>
<b>4.1.4</b> <b>Requirements for mass</b> .....	<b>8</b>
<b>4.2</b> <b>Requirements of natural stone for rough blocks</b> .....	<b>8</b>
<b>4.2.1</b> <b>General</b> .....	<b>8</b>
<b>4.2.2</b> <b>Denomination</b> .....	<b>8</b>
<b>4.2.3</b> <b>Visual appearance</b> .....	<b>8</b>
<b>4.2.4</b> <b>Apparent density and open porosity</b> .....	<b>9</b>
<b>4.2.5</b> <b>Flexural strength</b> .....	<b>9</b>
<b>4.2.6</b> <b>Other requirements</b> .....	<b>9</b>
<b>5</b> <b>Marking</b> .....	<b>9</b>
<b>6</b> <b>Evaluation of conformity and factory production control</b> .....	<b>9</b>
<b>6.1</b> <b>Evaluation of conformity</b> .....	<b>9</b>
<b>6.2</b> <b>Initial type testing</b> .....	<b>10</b>
<b>6.3</b> <b>Factory production control</b> .....	<b>10</b>
<b>Annex A</b> (informative) <b>Sampling</b> .....	<b>12</b>
<b>A.1</b> <b>General</b> .....	<b>12</b>
<b>A.2</b> <b>Principles of sampling</b> .....	<b>12</b>
<b>A.3</b> <b>Taking bulk samples</b> .....	<b>12</b>
<b>A.4</b> <b>Preparing a sampling plan</b> .....	<b>12</b>
<b>A.5</b> <b>Sampling apparatus</b> .....	<b>13</b>
<b>A.6</b> <b>Sampling methods</b> .....	<b>13</b>
<b>A.6.1</b> <b>General</b> .....	<b>13</b>
<b>A.6.2</b> <b>Sampling from quarries</b> .....	<b>13</b>
<b>A.6.3</b> <b>Sampling from plants</b> .....	<b>14</b>
<b>A.6.4</b> <b>Sampling from buildings</b> .....	<b>14</b>
<b>A.7</b> <b>Marking, packaging and dispatch of the samples</b> .....	<b>14</b>
<b>A.8</b> <b>Sampling report</b> .....	<b>14</b>
<b>Bibliography</b> .....	<b>16</b>

## Foreword

This document (EN 1467:2012) has been prepared by Technical Committee CEN/TC 246 “Natural stones”, the secretariat of which is held by UNI.

This European Standard shall be given the status of a national standard, either by publication of an identical text or by endorsement, at the latest by October 2012, and conflicting national standards shall be withdrawn at the latest by October 2012.

Attention is drawn to the possibility that some of the elements of this document may be the subject of patent rights. CEN [and/or CENELEC] shall not be held responsible for identifying any or all such patent rights.

This document supersedes EN 1467:2003.

This European Standard is one of a series of standards for requirements of natural stone products which includes the following:

- EN 1467, *Natural stone — Rough blocks — Requirements*
- EN 1468, *Natural stone — Rough slabs — Requirements*
- EN 1469, *Natural stone products — Slabs for cladding — Requirements*
- EN 12057, *Natural stone products — Modular tiles — Requirements*
- EN 12058, *Natural stone products — Slabs for floors and stairs — Requirements*
- EN 12059, *Natural stone products — Dimensional stone work — Requirements*

Other standards on natural stone are produced by

a) CEN/TC 178

- 1) EN 1341, *Slabs of natural stone for external paving — Requirements and test methods*
- 2) EN 1342, *Setts of natural stone for external paving — Requirements and test methods*
- 3) EN 1343, *Kerbs of natural stone for external paving — Requirements and test methods*

b) CEN/TC 128

- 1) EN 12326-1, *Slate and stone products for discontinuous roofing and cladding — Part 1: Product specification*
- 2) EN 12326-2, *Slate and stone products for discontinuous roofing and cladding — Part 2: Methods of test for slate and carbonate slate*

c) CEN/TC 125

- 1) EN 771-6, *Specification for masonry units — Part 6: Natural stone masonry units*

Other standards are relevant to stone aggregates for concrete, roads, railways and armourstone.

According to the CEN/CENELEC Internal Regulations, the national standards organizations of the following countries are bound to implement this European Standard: Austria, Belgium, Bulgaria, Croatia, Cyprus, Czech Republic, Denmark, Estonia, Finland, France, Germany, Greece, Hungary, Iceland, Ireland, Italy, Latvia, Lithuania, Luxembourg, Malta, Netherlands, Norway, Poland, Portugal, Romania, Slovakia, Slovenia, Spain, Sweden, Switzerland, Turkey and the United Kingdom.

## 1 Scope

This European Standard specifies requirements for rough blocks of natural stone from which products for use in building or commemorative stones and other similar applications are made.

It does not cover artificially agglomerated stony material nor installation.

## 2 Normative references

The following documents, in whole or in part, are normatively referenced in this document and are indispensable for its application. For dated references, only the edition cited applies. For undated references, the latest edition of the referenced document (including any amendments) applies.

EN 1936, *Natural stone test methods — Determination of real density and apparent density, and of total and open porosity*

EN 12372, *Natural stone test methods — Determination of flexural strength under concentrated load*

EN 12407, *Natural stone test methods — Petrographic examination*

EN 12440, *Natural stone — Denomination criteria*

EN 12670:2001, *Natural stone — Terminology*

EN 13161, *Natural stone test methods — Determination of flexural strength under constant moment*

EN 13373, *Natural stone test methods — Determination of geometric characteristics on units*

NOTE Besides the European Standards for test methods mentioned in this clause, there exist further standards which can be used for scientific examinations, but which are not relevant for the application in practice according to this European Standard.

## 3 Terms and definitions

For the purposes of this document, the terms and definitions given in EN 12670:2001 and the following apply.

### 3.1

#### **commercial size of a rough block**

size which is obtained by reducing each net dimension by 0,05 m (see Figure 1)

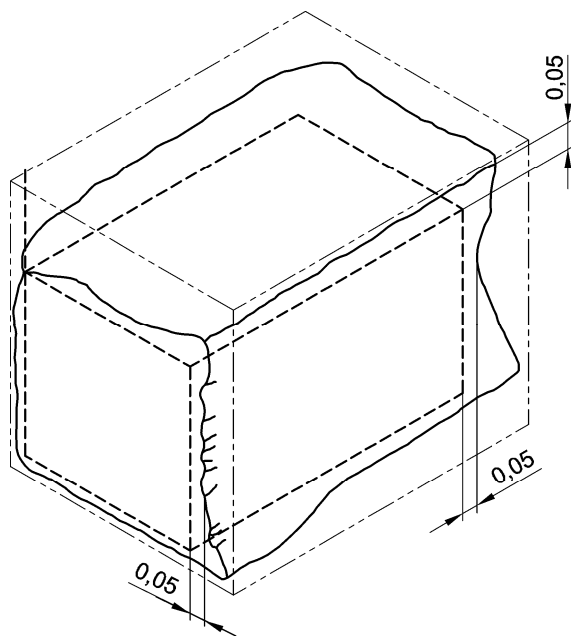

**Key**  
- - - - - gross size  
- - - - - commercial size

**Figure 1 — Gross sizes, commercial sizes of a rough block**

**3.2  
dimensions of a rough block**

length  $l$ , width  $b$  and height  $h$  are the dimensions of a squared rough block. They are given in the stated sequence in meters to two decimals places

**3.2.1  
length**

$l$   
greater side in a natural layer where appropriate

**3.2.2  
width**

$b$   
smaller side in the natural layer or at right angles to length

**3.2.3  
height**

$h$   
side at right angles to the natural layer (see Figure 2) or to the plane containing length  $l$  and width  $b$



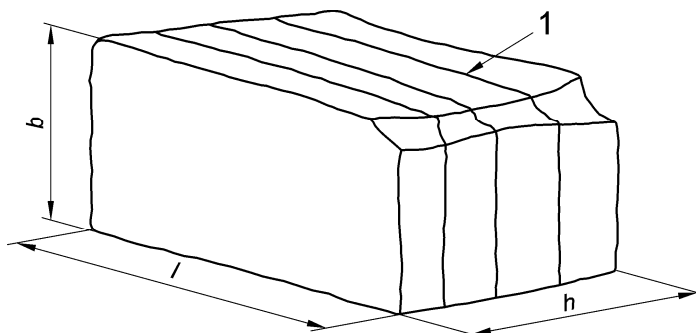

**Key**

1 natural layer

**Figure 2 — Dimensions of a rough block**

**3.3**

**gross size of the rough block**

size defined by the lengths of the edges of the smallest parallelepiped circumscribed to a rough block (see Figure 1)

**3.4**

**net size of a rough block**

size which is determined in the following manner: Establish the greatest inscribed parallelepiped block which shall not contain any sides without right angles nor contain drill holes and other holes. The resulting figure is the net size

**3.5**

**rough block**

basis of the usable stone consisting of rocks obtained directly from quarries or erratics with no processing whatsoever except extraction and shaping by cutting or splitting

**3.6**

**rough block of specific size**

squared rough block with certain given dimensions

**3.7**

**shapeless rough block**

rough block without regular shape and size

**3.8**

**squared rough block**

rough block which corresponds approximately to a regular parallelepiped

Note 1 to entry: Normally the ratio obtainable by dividing the mass of the squared rough block by the apparent density should be bigger than 80 % of the gross size. If such a ratio is equal to or less than 80 %, the block is considered a shapeless rough block.

## 4 Requirements

### 4.1 Requirements for geometric characteristics

#### 4.1.1 Measurement criteria

All measurements shall be carried out in accordance with EN 13373 and indicated in metres to two decimal places.

#### **4.1.2 Requirements on shape**

The six sides of squared rough block shall be approximately flat, right-angled and parallel, and correspond to the shape of a parallelepiped. Local deviations from the parallelepiped shape are permitted.

Shapeless rough blocks for commercial purposes are only measured by mass, (see 4.1.4); gross size shall be provided upon request.

Rough blocks of specific size shall have dimensions not lower than the minimum values and not greater than the maximum values agreed between the purchaser and supplier.

#### **4.1.3 Requirements for volume**

The volume of a rough block shall be stated in cubic metres to three decimal places. The volume may be calculated by dividing the mass of the block by the apparent density.

#### **4.1.4 Requirements for mass**

The mass of a rough block shall be stated in tonnes with three decimals. The mass shall be obtained by weighing; for squared blocks the approximate mass may be obtained by multiplying the volume by the apparent density.

### **4.2 Requirements of natural stone for rough blocks**

#### **4.2.1 General**

The following characteristics shall be declared where requested by this European Standard, or with reference to use conditions.

The declared values shall be representative of the current production. However, due to natural variations of the stone materials, deviations from the declared values may occur. Expected deviations shall be indicated by the manufacturer.

In case of layered stone: If a rough block contains different types of stones (see 4.2.2) all characteristics shall be declared.

#### **4.2.2 Denomination**

The denomination (traditional name, petrological family, typical colour and place of origin) shall always be declared in accordance with EN 12440.

NOTE The place of origin can be given by GPS coordinates.

The petrologic definition shall be determined in accordance with EN 12407.

#### **4.2.3 Visual appearance**

This characteristic shall be declared upon request.

The colour, veining, texture, etc. of the stone shall be identified visually (for example by a polished reference sample). The reference sample shall be provided by the supplier.

Any visual variations, for example inclusions and veins, are permissible, provided that they are characteristic of the relevant type of natural stone and provided that they do not adversely affect the performances of the stone products.

#### **4.2.4 Apparent density and open porosity**

This characteristic shall always be declared.

The apparent density and open porosity shall be determined using the test method in EN 1936 and the mean value, lower expected value and standard deviation shall be declared.

#### **4.2.5 Flexural strength**

This characteristic shall always be declared.

The flexural strength shall be determined using the test method in EN 12372 or EN 13161, and the mean value, lower expected value and standard deviation shall be declared.

#### **4.2.6 Other requirements**

Where required, for example when the derived product is to be used for a specific purpose, additional tests may be requested in accordance with relevant product standard (see EN 1469 [1], EN 12057 [2], EN 12058 [3], etc.).

### **5 Marking**

As a minimum of identification, each consignment shall carry the following indications:

- the denomination of the natural stone, in accordance with EN 12440;
- the mass and the volume of each block;
- the dimensions (including at least gross and commercial sizes) of each block.

The direction of the natural layer of each block shall be clearly marked where appropriate.

Each block shall be clearly identified by a recorded identification system.

### **6 Evaluation of conformity and factory production control**

#### **6.1 Evaluation of conformity**

The compliance with the requirements of this European Standard and with the stated values or classes of reaction to fire shall be demonstrated by carrying out initial type testing. Additionally, the manufacturer shall exercise a permanent factory production control (FPC) and keep record of the results for at least 2 years.

The declared values shall be representative of the current production, for example the lowest expected value or the minimum test value in normal production.

For sampling see Annex A.

When the rough blocks manufacturer declares conformity with some characteristics included in a product standard (see EN 1469 [1], EN 12057 [2], EN 12058 [3], etc.), the evaluation of conformity of the block shall include initial type testing and factory production control as described in the appropriate product standard.

## 6.2 Initial type testing

Initial type testing of a natural stone rough block, as given in Table 1, shall be carried out

- on the first application of this European Standard or at the beginning of production of a new type of stone;
- when significant variations occur in the material that are determined visually or by significant changes in FPC results.

Tests previously performed in accordance with the provisions of this European Standard (same type of stone, same characteristic measured with same test method, same sampling procedure and system of attestation of conformity) may be taken into account.

The results of the selected tests shall be expressed as referred to in 4.2.

**Table 1 — List of properties of rough blocks for initial type testing**

Reference to subclauses for applicability <sup>a</sup>	Properties/Characteristics	Test method in accordance with
4.2.2	Denomination	EN 12440 and EN 12407
4.2.3	Visual appearance	Visual
4.2.4	Apparent density and open porosity	EN 1936
4.2.5	Flexural strength	EN 12372 or EN 13161

<sup>a</sup> Reference shall be made to these subclauses in order to decide which tests need to be declared.

## 6.3 Factory production control

**6.3.1** A factory production control system (FPC) shall be established and documented. The factory production control system shall consist of procedures for the internal control of production. The results of the tests carried out during FPC shall demonstrate that products placed on the market conform with this European Standard and with the manufacturer's declared values in accordance with 4.1 and 4.2.

In cases when the processing of the stone is likely to change the characteristics of the finished product relative to the initial material (e.g. in consequence of the type of processing or because the use of patching, fillers or other similar products for natural holes, faults, cracks and similar), then this has to be considered within the FPC, as requested by this European Standard.

**6.3.2** The internal control shall consist of regular inspection checks and tests, and the utilisation of the results to control materials, equipment, the production process and the rough blocks.

**6.3.3** The tests and inspection checks shall be in accordance with Table 2.

**Table 2 — Control frequency of Factory production control**

Reference to subclauses for applicability <sup>a</sup>	Characteristics	Control frequency	Test method in accordance with
4.1	Geometric characteristics	Every production lot <sup>b</sup>	EN 13373
4.2.3	Visual appearance		Visual
4.2.4	Apparent density and open porosity	In accordance with FPC system but at least every 2 years	EN 1936
4.2.5	Flexural strength		EN 12372 or EN 13161
<sup>a</sup> Reference shall be made to these subclauses in order to decide which tests need to be declared. <sup>b</sup> The dimension or amount of a production lot shall be determined by the manufacturer, having as reference the daily production quantity and the number of deliveries of the considered quantity of slabs.			

The results of the tests carried out during FPC shall demonstrate conformity to the requirements declared in 4.1 and 4.2.

**6.3.4** Manufacturers' records shall include at least the following:

- a) identification of the product tested;
- b) information on sampling (see Annex A):
  - 1) place and date of sampling;
  - 2) identification of the production lot sampled;
  - 3) frequencies of sampling;
  - 4) size and number of samples;
- c) the test methods applied;
- d) the results of the tests carried out;
- e) calibration records of apparatus.

## **Annex A** **(informative)**

### **Sampling**

#### **A.1 General**

This annex specifies methods for obtaining samples of natural stone from quarries, plants or buildings. Sampling from buildings may be necessary if the delivered natural stone product has already been applied in a building.

The aim of sampling is to obtain a bulk sample that is representative of the average properties of the batch and of its variabilities.

The methods described are based on manual procedures, and are limited to building and civil engineering purposes.

It is important that samplers are trained accordingly in the application of the methods set out in this document.

In the case of a dispute, or if tests are to be done by more than one organization, all interested parties shall have the opportunity to observe the sampling and shall agree upon the number of sampling increments to be taken.

#### **A.2 Principles of sampling**

Proper and careful sampling and sample transport is a prerequisite for an analysis that will give reliable results. An adequate number of samples have to be taken in order to obtain a good estimation of the natural heterogeneity of the batch.

The sampler shall be informed of the aim of the sampling.

#### **A.3 Taking bulk samples**

The number and size of samples depend on the test methods for which they are taken. The number and shape of specimens are given in the relevant test methods.

#### **A.4 Preparing a sampling plan**

A sampling plan shall be prepared prior to sampling, taking into account the following:

- the type of the natural stone (following EN 12440 and EN 12670);
- the aim of the sampling including a list of the properties to be tested;
- the identification of sampling points;
- the approximate size of samples;
- the number of samples;

- the sampling apparatus to be used;
- the methods of sampling;
- the marking, packaging and dispatch of the samples.

## **A.5 Sampling apparatus**

Any suitable cutting equipment for natural stone may be used for sampling. In addition, drills, which are suitable for taking drill cores, may be used.

## **A.6 Sampling methods**

### **A.6.1 General**

The sampling methods will inevitably involve the samplers working at a quarry, plant or building. Regulations for safety and ergonomics shall be followed.

### **A.6.2 Sampling from quarries**

#### **A.6.2.1 General**

The sample shall be taken by a qualified specialist, experienced in the examination of natural stone deposits. The main objective of sampling from such deposits is to establish the average, the range of variations and the differences in the structure and properties of the natural stone, taking into account the fabric, geological structure and the anticipated quarrying conditions.

#### **A.6.2.2 Sampling of solid rock**

##### a) Identification of anisotropy and orientation of samples

If the exploratory work reveals a pronounced fabric or geological structure which is not necessarily visible at the sample scale (e.g. stratification, massive bedding, lamination, cleavage or rift), the sample shall be marked accordingly.

##### b) Sampling for petrographic analysis

For petrographic analysis, hand specimens shall be taken from all distinct types and varieties that characterize the rock in terms of mineral composition, fabric and geological structure.

Samples from drilling (cores and pieces) may also be used.

In addition to samples of fresh material, samples shall also be taken to illustrate the effects of weathering.

##### c) Sampling for physical testing

For physical testing, sample blocks shall be used as samples, their number and location dependent on the results of the petrographic analysis and the required test methods.

The sample blocks shall measure approximately 0,40 m x 0,25 m x 0,25 m or more where a coarse-grained and/or a large-pored rock is to be sampled.

It is recommended that samples be taken from larger natural stones which have been the least affected by blastings. Care has to be applied to ensure the sample blocks do not show any hairline cracks resulting from the removal process.

Samples may also be cut from rough blocks, slabs or dimension stones, the number and size of samples dependent on the particular test method.

### **A.6.3 Sampling from plants**

A representative sample of adequate size and characteristic of the natural stone in terms of mineral composition, fabric and geological structure, shall be taken from the material to be tested (e. g. slabs, dimension stones), taking into account the intended use of the material.

### **A.6.4 Sampling from buildings**

Sampling points shall be selected according to the rules for obtaining a representative sample, taking into consideration any differences in properties visible to the naked eye. Where necessary, taking a single slab to assess the mechanical properties in situ will be sufficient.

The location of the sample in the building shall be reported.

## **A.7 Marking, packaging and dispatch of the samples**

The samples or containers shall be clearly and durably marked. Marking shall include

- a) a unique code, or
- b) identification of the laboratory samples, including place of sampling, date of sampling and denomination of the material.

The laboratory samples shall be packed and transported in such a way that they are protected from damage.

## **A.8 Sampling report**

**A.8.1** The sampler shall prepare a sampling report for each laboratory sample or for each group of laboratory samples from a single source. The sampling report shall refer to this European Standard and state the following:

- a) the sampling report identification (serial number);
- b) the laboratory sample identification mark(s);
- c) the date and place of sampling;
- d) sampling point(s) or identification of the batch sampled;
- e) a reference to the sampling plan prepared according to A.4;
- f) the name of the sampler(s).

**A.8.2** Depending on the circumstances, other information might be relevant. Table A.1 shows an example of a comprehensive sampling report.



**Table A.1 — Example of a sampling report**

Sampling report identification (serial n°):	
Laboratory sample identification mark:	no. of package
Description of the natural stone and sampling places	
Name of the quarry or production plant or building:	
Name of producer:	
Origin of batch:	
Purpose for which the natural stone is to be used:	
Location of sampling point(s):	
Identification of the batch:	
Size of the batch:	
Other comments (e. g. warnings, if appropriate):	
Description of the sampling method	
Date and time of sampling:	
Reference to sampling plan used:	
Sampling procedure (drilling, cutting, etc.):	
Purpose of the sampling:	
Samples	
No. and dimensions of samples:	
Other comments:	
Dispatch of the samples:	
Sampler(s) (print name):	
Contract details	
Contract identification:	
Name and address of party requesting the sampling:..... .....	
Name of person(s) present at sampling:..... .....	
Signatures:..... ..... .....	

## Bibliography

- [1] EN 1469, *Natural stone products — Slabs for cladding — Requirements*
- [2] EN 12057, *Natural stone products — Modular tiles — Requirements*
- [3] EN 12058, *Natural stone products — Slabs for floors and stairs — Requirements*



# British Standards Institution (BSI)

BSI is the national body responsible for preparing British Standards and other standards-related publications, information and services.

BSI is incorporated by Royal Charter. British Standards and other standardization products are published by BSI Standards Limited.

## About us

We bring together business, industry, government, consumers, innovators and others to shape their combined experience and expertise into standards-based solutions.

The knowledge embodied in our standards has been carefully assembled in a dependable format and refined through our open consultation process. Organizations of all sizes and across all sectors choose standards to help them achieve their goals.

## Information on standards

We can provide you with the knowledge that your organization needs to succeed. Find out more about British Standards by visiting our website at [bsigroup.com/standards](http://bsigroup.com/standards) or contacting our Customer Services team or Knowledge Centre.

## Buying standards

You can buy and download PDF versions of BSI publications, including British and adopted European and international standards, through our website at [bsigroup.com/shop](http://bsigroup.com/shop), where hard copies can also be purchased.

If you need international and foreign standards from other Standards Development Organizations, hard copies can be ordered from our Customer Services team.

## Subscriptions

Our range of subscription services are designed to make using standards easier for you. For further information on our subscription products go to [bsigroup.com/subscriptions](http://bsigroup.com/subscriptions).

With **British Standards Online (BSOL)** you'll have instant access to over 55,000 British and adopted European and international standards from your desktop. It's available 24/7 and is refreshed daily so you'll always be up to date.

You can keep in touch with standards developments and receive substantial discounts on the purchase price of standards, both in single copy and subscription format, by becoming a **BSI Subscribing Member**.

**PLUS** is an updating service exclusive to BSI Subscribing Members. You will automatically receive the latest hard copy of your standards when they're revised or replaced.

To find out more about becoming a BSI Subscribing Member and the benefits of membership, please visit [bsigroup.com/shop](http://bsigroup.com/shop).

With a **Multi-User Network Licence (MUNL)** you are able to host standards publications on your intranet. Licences can cover as few or as many users as you wish. With updates supplied as soon as they're available, you can be sure your documentation is current. For further information, email [bsmusales@bsigroup.com](mailto:bsmusales@bsigroup.com).

## BSI Group Headquarters

389 Chiswick High Road London W4 4AL UK

## Revisions

Our British Standards and other publications are updated by amendment or revision.

We continually improve the quality of our products and services to benefit your business. If you find an inaccuracy or ambiguity within a British Standard or other BSI publication please inform the Knowledge Centre.

## Copyright

All the data, software and documentation set out in all British Standards and other BSI publications are the property of and copyrighted by BSI, or some person or entity that owns copyright in the information used (such as the international standardization bodies) and has formally licensed such information to BSI for commercial publication and use. Except as permitted under the Copyright, Designs and Patents Act 1988 no extract may be reproduced, stored in a retrieval system or transmitted in any form or by any means – electronic, photocopying, recording or otherwise – without prior written permission from BSI. Details and advice can be obtained from the Copyright & Licensing Department.

## Useful Contacts:

### Customer Services

**Tel:** +44 845 086 9001

**Email (orders):** [orders@bsigroup.com](mailto:orders@bsigroup.com)

**Email (enquiries):** [cservices@bsigroup.com](mailto:cservices@bsigroup.com)

### Subscriptions

**Tel:** +44 845 086 9001

**Email:** [subscriptions@bsigroup.com](mailto:subscriptions@bsigroup.com)

### Knowledge Centre

**Tel:** +44 20 8996 7004

**Email:** [knowledgecentre@bsigroup.com](mailto:knowledgecentre@bsigroup.com)

### Copyright & Licensing

**Tel:** +44 20 8996 7070

**Email:** [copyright@bsigroup.com](mailto:copyright@bsigroup.com)



...making excellence a habit.™