

Unshaped refractory products —

Part 7: Tests on pre-formed shapes

The European Standard EN 1402-7:2003 has the status of a
British Standard

ICS 81.080

National foreword

This British Standard is the official English language version of EN 1402-7:2003. It supersedes DD ENV 1402-7:1998 which is withdrawn.

The UK participation in its preparation was entrusted to Technical Committee RPI/1, Refractories, which has the responsibility to:

- aid enquirers to understand the text;
- present to the responsible international/European committee any enquiries on the interpretation, or proposals for change, and keep the UK interests informed;
- monitor related international and European developments and promulgate them in the UK.

A list of organizations represented on this committee can be obtained on request to its secretary.

Cross-references

The British Standards which implement international or European publications referred to in this document may be found in the *BSI Catalogue* under the section entitled “International Standards Correspondence Index”, or by using the “Search” facility of the *BSI Electronic Catalogue* or of British Standards Online.

This publication does not purport to include all the necessary provisions of a contract. Users are responsible for its correct application.

Compliance with a British Standard does not of itself confer immunity from legal obligations.

Summary of pages

This document comprises a front cover, an inside front cover, the EN title page, pages 2 to 24, an inside back cover and a back cover.

The BSI copyright notice displayed in this document indicates when the document was last issued.

This British Standard, was published under the authority of the Standards Policy and Strategy Committee on 28 October 2003

Amendments issued since publication

Amd. No.	Date	Comments

© BSI 28 October 2003

ISBN 0 580 42827 3

English version

Unshaped refractory materials - Part 7: Tests on pre-formed shapes

Produits et matériaux réfractaires - Partie 7: Essais sur pièces pré-formées

Ungeformte feuerfeste Erzeugnisse - Teil 7: Prüfungen an Fertigteilen

This European Standard was approved by CEN on 20 June 2003.

CEN members are bound to comply with the CEN/CENELEC Internal Regulations which stipulate the conditions for giving this European Standard the status of a national standard without any alteration. Up-to-date lists and bibliographical references concerning such national standards may be obtained on application to the Management Centre or to any CEN member.

This European Standard exists in three official versions (English, French, German). A version in any other language made by translation under the responsibility of a CEN member into its own language and notified to the Management Centre has the same status as the official versions.

CEN members are the national standards bodies of Austria, Belgium, Czech Republic, Denmark, Finland, France, Germany, Greece, Hungary, Iceland, Ireland, Italy, Luxembourg, Malta, Netherlands, Norway, Portugal, Slovakia, Spain, Sweden, Switzerland and United Kingdom.



EUROPEAN COMMITTEE FOR STANDARDIZATION
COMITÉ EUROPÉEN DE NORMALISATION
EUROPÄISCHES KOMITEE FÜR NORMUNG

Management Centre: rue de Stassart, 36 B-1050 Brussels

Contents

	page
Foreword.....	3
1 Scope	4
2 Normative references	4
3 Terms and definitions.....	4
4 Principle	7
5 Apparatus	7
6 Inspection by attributes	9
6.1 Preparation of the test piece.....	9
6.2 Measurement of dimensions	9
6.3 Measurement of angles	10
6.4 Measurement of warpage.....	10
6.5 Measurement of corner defects.....	11
6.6 Measurement of edge defects	12
6.7 Measurement of craters and bubbles	13
6.8 Measurement of cracks	14
6.9 Measurement of protrusions and indentations	15
6.10 Measurement of fins	15
6.11 Segregations	15
6.12 Friability	15
7 Inspection by variables	16
7.1 Destructive test methods	16
7.1.1 General.....	16
7.1.2 Physical properties.....	16
7.1.3 Moisture content (see NOTE 2 of 7.1.4).....	16
7.1.4 Loss on ignition	16
7.2 Non-destructive test methods	17
7.2.1 Ultrasonic testing.....	17
7.2.2 Determination of the resonant frequency by mechanical shock.....	19
7.2.3 Rebound hammer.....	21
7.2.4 Mass	22
7.2.5 Bulk density.....	22
8 Test report	22
Bibliography	24

Foreword

This document (EN 1402-7:2003) has been prepared by Technical Committee CEN/TC 187 "Refractory products and materials", the secretariat of which is held by BSI.

This European Standard shall be given the status of a national standard, either by publication of an identical text or by endorsement, at the latest by April 2004, and conflicting national standards shall be withdrawn at the latest by April 2004.

This document supersedes ENV 1402-7:1998.

EN 1402 "Unshaped refractory products" consists of eight parts:

- *Part 1* *Introduction and classification*
- *Part 2* *Sampling for testing*
- *Part 3* *Characterization as received*
- *Part 4* *Determination of consistency of castables*
- *Part 5* *Preparation and treatment of test pieces*
- *Part 6* *Measurement of physical properties*
- *Part 7* *Tests on pre-formed shapes*
- *Part 8* *Determination of complementary properties*

According to the CEN/CENELEC Internal Regulations, the national standards organizations of the following countries are bound to implement this European Standard: Austria, Belgium, Czech Republic, Denmark, Finland, France, Germany, Greece, Hungary, Iceland, Ireland, Italy, Luxembourg, Malta, Netherlands, Norway, Portugal, Slovakia, Spain, Sweden, Switzerland and the United Kingdom.

1 Scope

This European Standard specifies methods for the testing of as-delivered pre-formed shapes. It applies to shapes fabricated from dense and insulating castables and ramming materials as defined in EN 1402-1.

NOTE Acceptance values for the individual test methods described should be agreed between the parties involved.

2 Normative references

This European Standard incorporates by dated or undated reference, provisions from other publications. These normative references are cited at the appropriate places in the text, and the publications are listed hereafter. For dated references, subsequent amendments to or revisions of any of these publications apply to this European Standard only when incorporated in it by amendment or revision. For undated references the latest edition of the publication referred to applies (including amendments).

EN 1402-1, *Unshaped refractory products – Part 1 Introduction and classification*.

EN 1402-6, *Unshaped refractory products – Part 6: Measurement of physical properties*.

3 Terms and definitions

For the purposes of this European Standard, the following terms and definitions apply.

3.1

corner defect

missing corner, defined by the three dimensions a , b and c as indicated in Figure 1

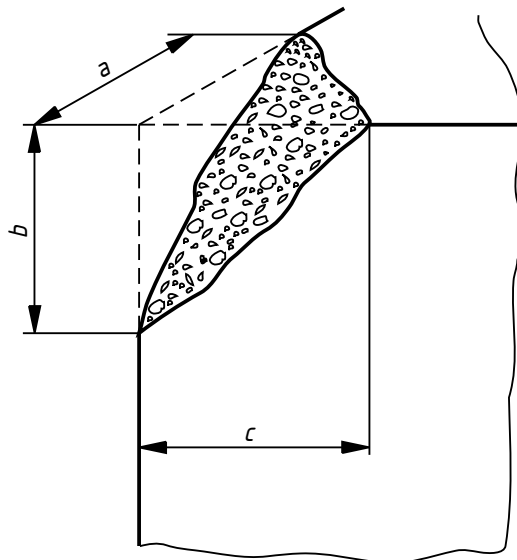

Key

a , b and c Three dimensions defining the missing corner

Figure 1 — Typical corner defect

3.2**edge defect**

missing edge, defined by the three dimensions, e , f , and g as indicated in Figure 2

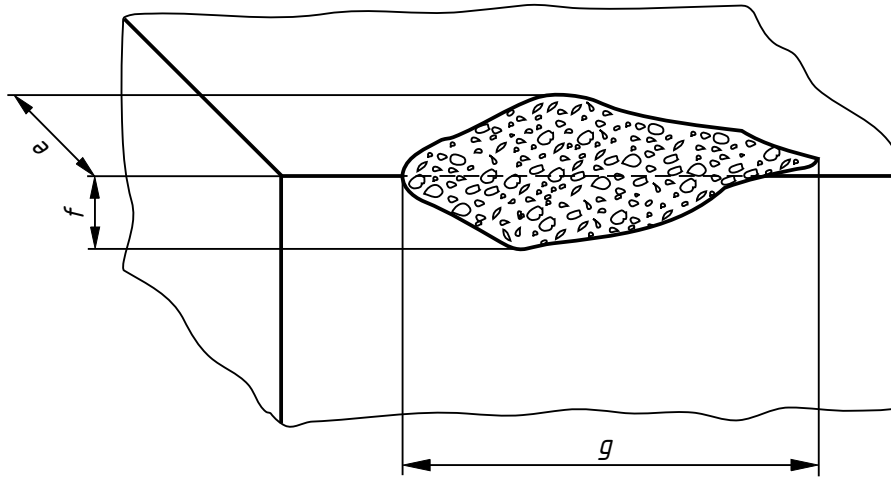
**Key**

e , f , and g Three dimensions defining the missing edge

Figure 2 — Typical edge defect

3.3**crater**

clearly defined hole in the surface of a shape whose parameters, i.e. maximum diameter, minimum diameter and depth, can be measured

NOTE Its origin can be a bubble produced during manufacture.

3.4**hairline cracks**

fine cracks visible on the surface of a shape whose length can be measured and whose width is less than or equal to 0,2 mm (see Figure 3)

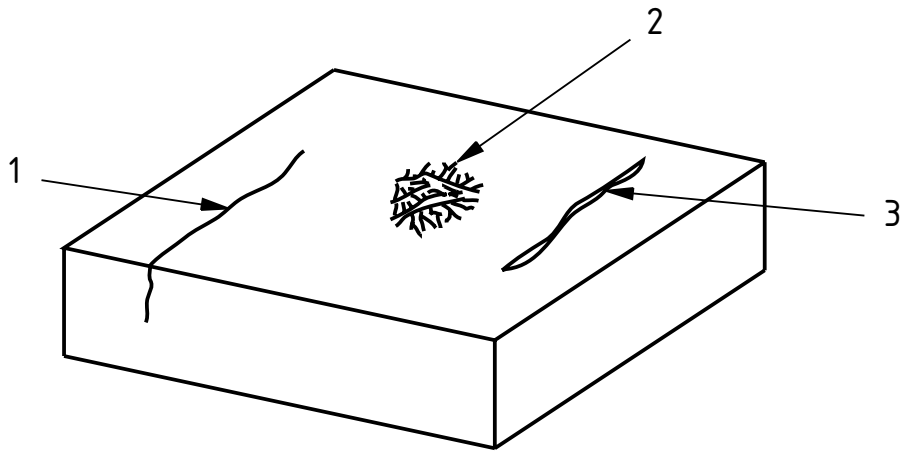

Key

- 1 Hairline crack
- 2 Surface crazing
- 3 Open cracks

Figure 3 — Typical cracks

3.5 surface crazing
network of hairline cracks confined to the surface of the shape (see Figure 3)

3.6 open cracks
cracks or tears on the surface whose length is more than 10 mm and whose width is more than 0,2 mm (see Figure 3)

3.7 protrusions and indentations
imperfections that can occur during fabrication or firing, if applicable

3.8 fins
thin layer of material on the face of a shape that projects beyond the edge

3.9 segregation
separation of aggregate and fines during fabrication to leave a honeycomb appearance and/or a layer of excess fines

3.10 friability
crumbly texture due to poor consolidation and/or mould leakage

3.11 warpage
deviation of a plane surface from being flat

4 Principle

Testing of pre-formed shapes by qualitative and/or quantitative methods. These methods are of two types:

- a) **Inspection by attributes** by evaluating the integrity of a refractory shape by visual inspection of cracks or other surface defects and by conformance to dimensional tolerances;
- b) **Inspection by variables** by evaluating the quality of a refractory shape by determining physical properties using appropriate destructive or non-destructive test methods.

NOTE It is not obligatory to use all the test methods described in this European Standard when determining the quality of a pre-formed shape.

5 Apparatus

5.1 Linear measuring devices, steel tape and/or callipers in accordance with the tolerance required and conforming to an accuracy twice the intended accuracy of the measurement.

NOTE Where possible, linear tolerances less than 1 mm should be measured with callipers. Steel tape measurements are accurate to the millimetre (0,5 mm can be estimated) whereas callipers are accurate to 0,1 mm.

5.2 Steel straightedge, at least 5 mm thick and of sufficient length to span the diagonal of the largest shape to be measured.

5.3 Two steel measuring wedges, which shall be either:

- a) type 1, at least 50 mm in length and 10 mm in thickness at one end, of uniform cross section for a length of at least 10 mm from that end and then tapering to zero thickness at the other end (see for example Figure 4a), or
- b) type 2, up to 160 mm in length with an even taper from 4 mm to zero (see for example Figure 4b).

Each wedge shall be graduated and numbered along the slope to show the thickness of the wedge between the base and the slope in increments of either 0,5 mm (type 1) or 0,1 mm (type 2).

Dimensions in millimetres

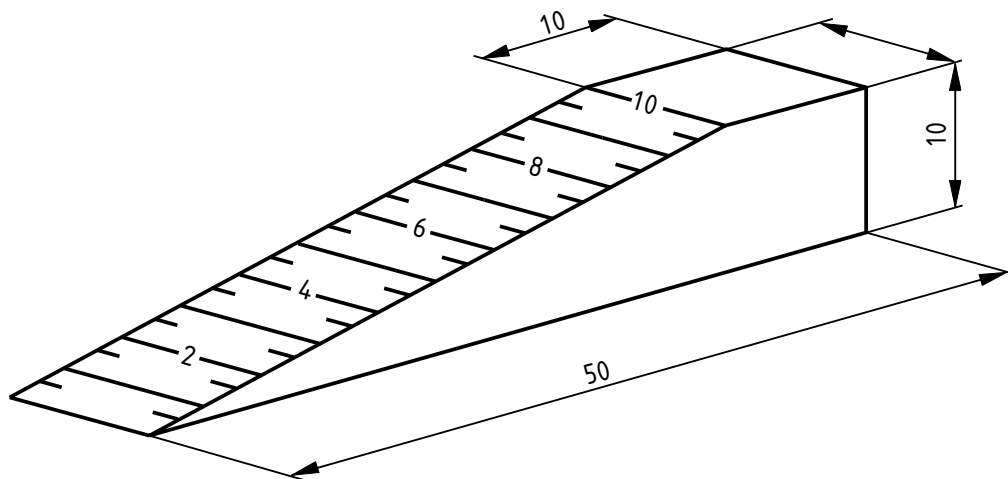

a) Type 1

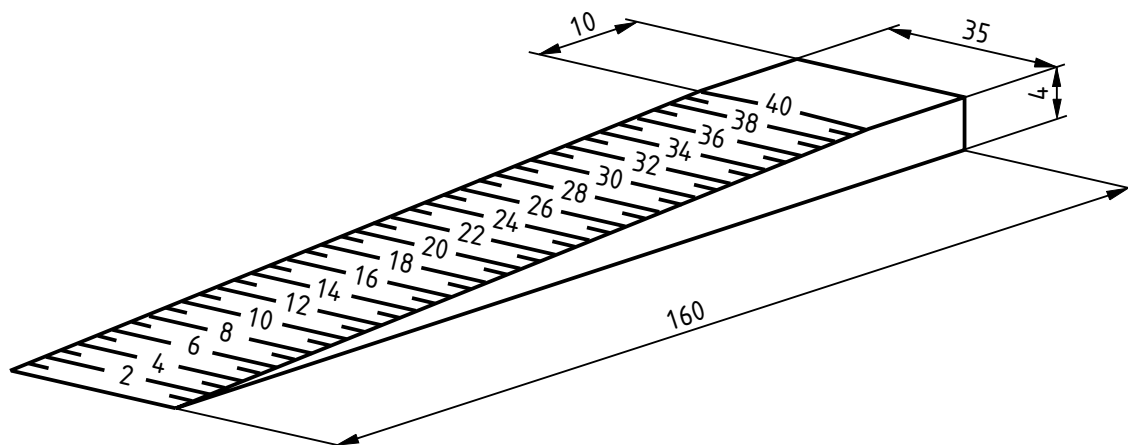

b) Type 2

Figure 4 — Two types of measuring wedge

- 5.4 **Graticule**, with 0,1 mm graduations and/or feeler gauges of an appropriate size and accuracy to be used for the measurement of crack width. If necessary, the gauges can be replaced by measuring wedges of appropriate accuracy.
- 5.5 **Sliding bevel**, for the measurement of angles.
- 5.6 **Depth gauge** calibrated in millimetres of depth, having a probe of 3 mm diameter.

5.7 Breakage defect sizer, with a slot uncovering 2 mm on both surfaces, for determination of minimum defect sizes for corner and edge defects, according to Figure 5.

NOTE 1 One breakage defect sizer can be used together with a steel straightedge for the measurement of corner defects (see 6.5). Two breakage defect sizers can be used together with a linear measuring device for the measurement of edge defects (see 6.6).

NOTE 2 A breakage defect sizer permits an objective definition of the point of departure for the measurement of the size of a broken edge.

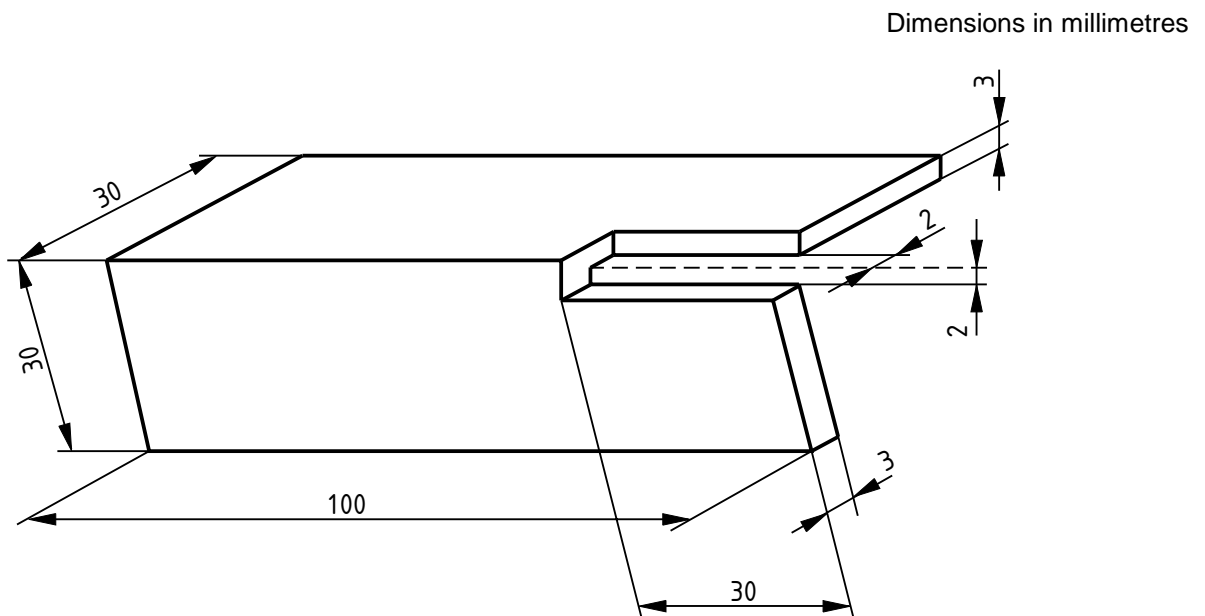

Figure 5 — Breakage defect sizer

5.8 Balance, capable of measuring to an accuracy of 1 %.

5.9 Ultrasonic pulse velocity measuring equipment.

5.10 Equipment for determining the resonant frequency by mechanical shock.

5.11 Rebound hammer.

5.12 Drying oven, capable of being controlled at $110\text{ °C} \pm 5\text{ °C}$.

5.13 Furnace, capable of operating at $1\ 050\text{ °C} \pm 5\text{ °C}$.

6 Inspection by attributes

6.1 Preparation of the test piece

The definition of edges may be improved, after any protrusions or indentations have been measured, by removing any projections such as fins or protrusions. This can normally be achieved by light abrasion.

6.2 Measurement of dimensions

Linear dimensions shall be measured by means of a linear measuring device (see 5.1), and unless otherwise agreed, shall be measured to the nearest 0,5 mm.

6.3 Measurement of angles

Angles shall be measured by adjusting the sliding bevel to fit the shape (see Figure 6) and the angle determined by use of a protractor (see Figure 7).

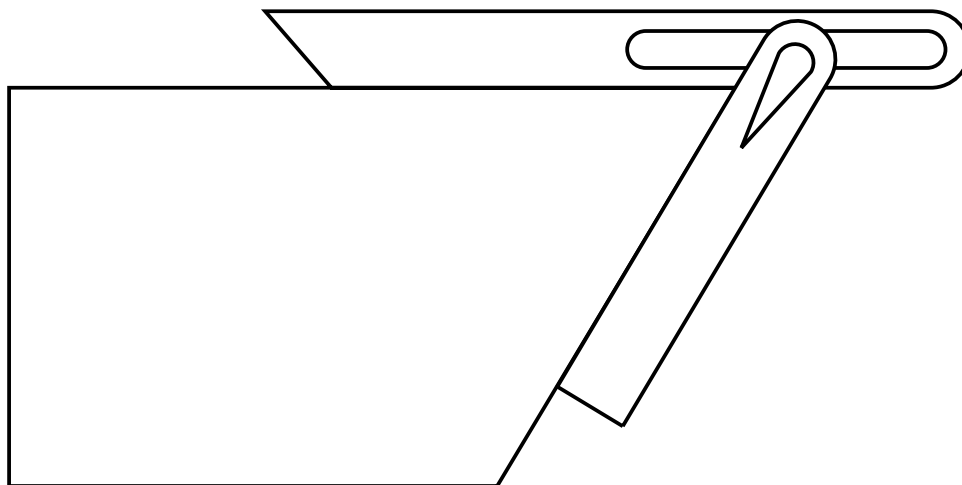

Figure 6 — Positioning the sliding level

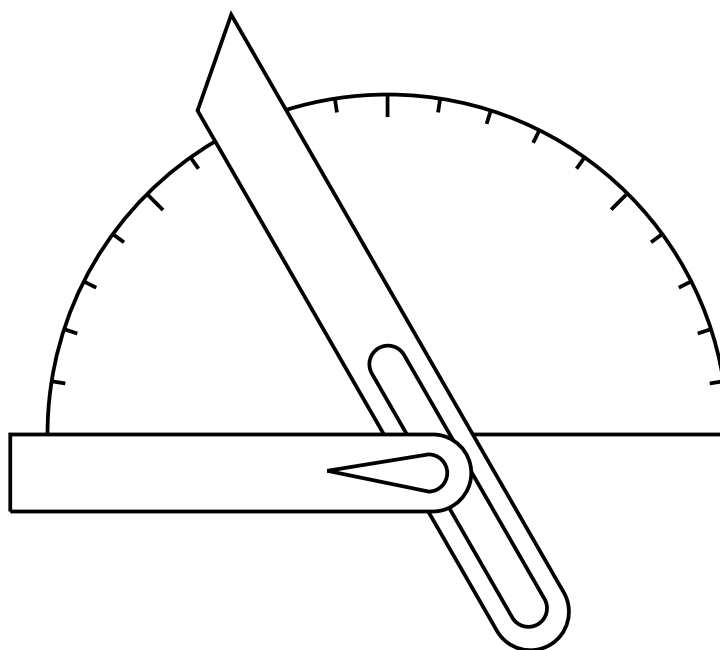

Figure 7 — Measurement of the angle

6.4 Measurement of warpage

For a concave surface, place the straightedge on edge across a diagonal of the surface being tested, insert a wedge at the point of maximum warpage (ensuring that the reading is not affected by raised imperfections on the castable surface) and record the maximum obtainable reading to the nearest 0,5 mm at the point of contact between the wedge and the straightedge.

For a convex surface, insert a wedge at each end of the straightedge and perpendicular to it as shown in Figure 8. Adjust the wedges, to a position not more than 15 mm from the corner of the shape, so that equal readings are

obtained from each of them, making certain that contact is maintained by the straightedge at the point of maximum convexity. Record the readings to the nearest 0,5 mm.

Calculate the warpage ratio, W in percent, using the equation:

$$W = \frac{h}{l} \times 100$$

where

l is the length of the diagonal of the surface being tested, in millimetres;

h is the reading of the amount of warpage, in millimetres.

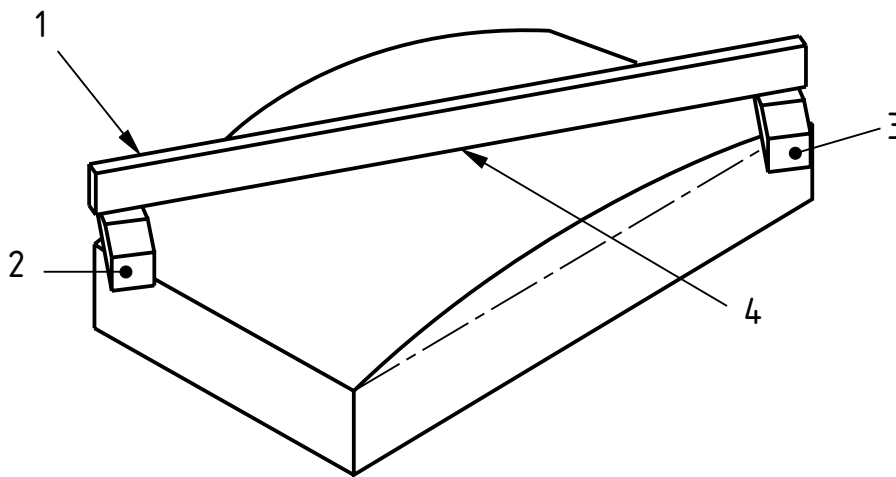

Key

- 1 Straightedge
- 2 Wedge
- 3 Wedge
- 4 Contact maintained at highest point of profile

Figure 8 — Measurement of convex warpage

6.5 Measurement of corner defects

Measure the dimensions a , b and c of a corner defect using a steel straightedge, a breakage defect sizer and a steel tape, as indicated in Figure 9. The breakage defect sizer shall be positioned along the edge to be measured in such a way that the leading edge of the slot coincides with the broken corner on at least one surface of the shape, as shown in Figure 10. The dimensions a , b , and c are measured between the steel straightedge and the leading edge of the breakage defect sizer, to the nearest mm.

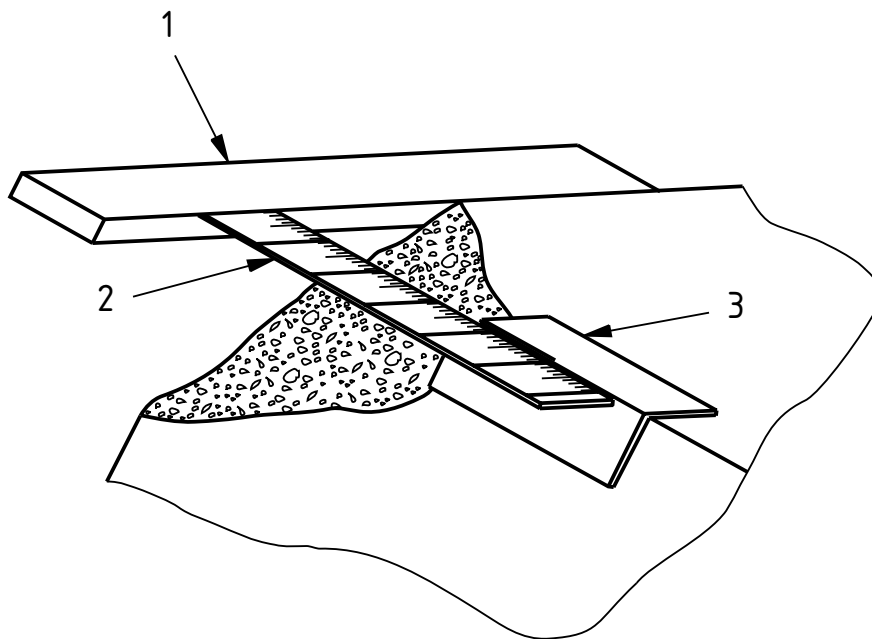

Key

- 1 Steel straightedge
- 2 Steel tape
- 3 Breakage defect sizer

Figure 9 — Measurement of a corner defect

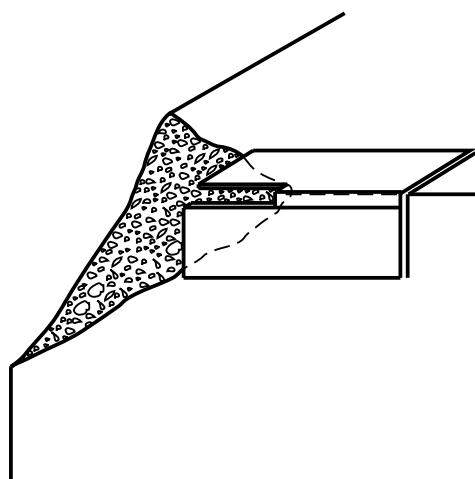
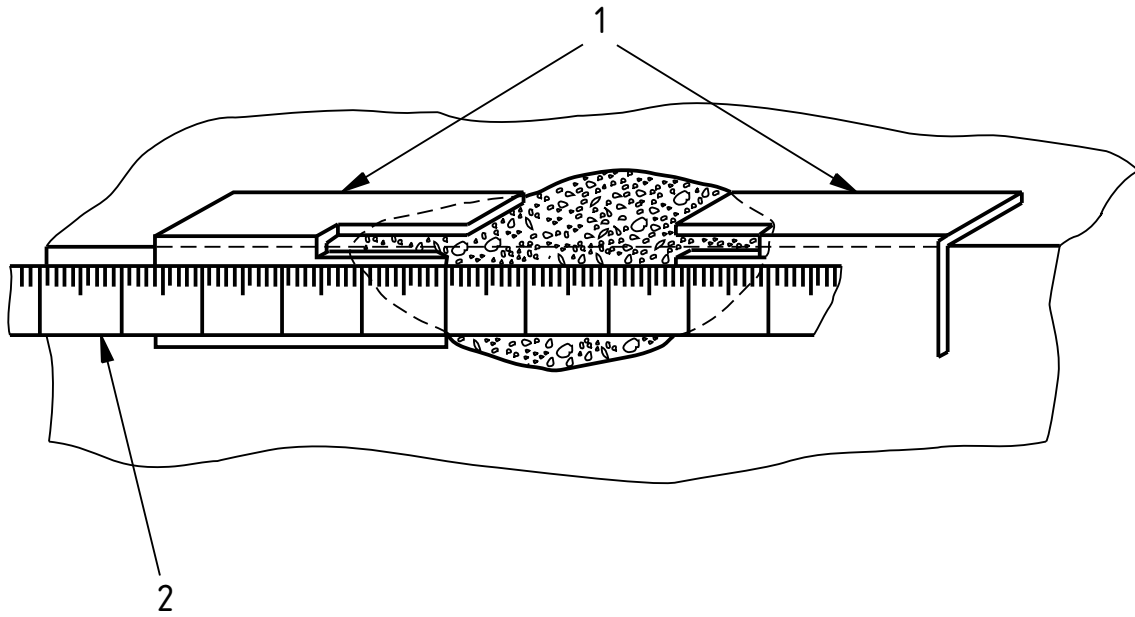

Figure 10 — Positioning the breakage defect sizer

6.6 Measurement of edge defects

Measure the length, g , of an edge defect using two breakage defect sizers and a steel tape, as indicated in Figure 11. Measure the depth of the edge defect as defined by e and f using a steel straightedge and a steel tape. Measure all dimensions to the nearest mm.

**Key**

- 1 Breakage defect sizers
- 2 Steel tape

Figure 11 — Measurement of the length of an edge defect

6.7 Measurement of craters and bubbles

Measure the maximum and minimum diameter of a crater using a steel tape as indicated in Figure 12. The apparent crater diameter, d_a , is given by the equation:

$$d_a = \frac{D + d}{2}$$

where

D is the maximum diameter of the crater, in mm;

d is the minimum diameter of the crater, in mm;

Measure the depth, h in mm, of a crater using a depth gauge as indicated in Figure 12.

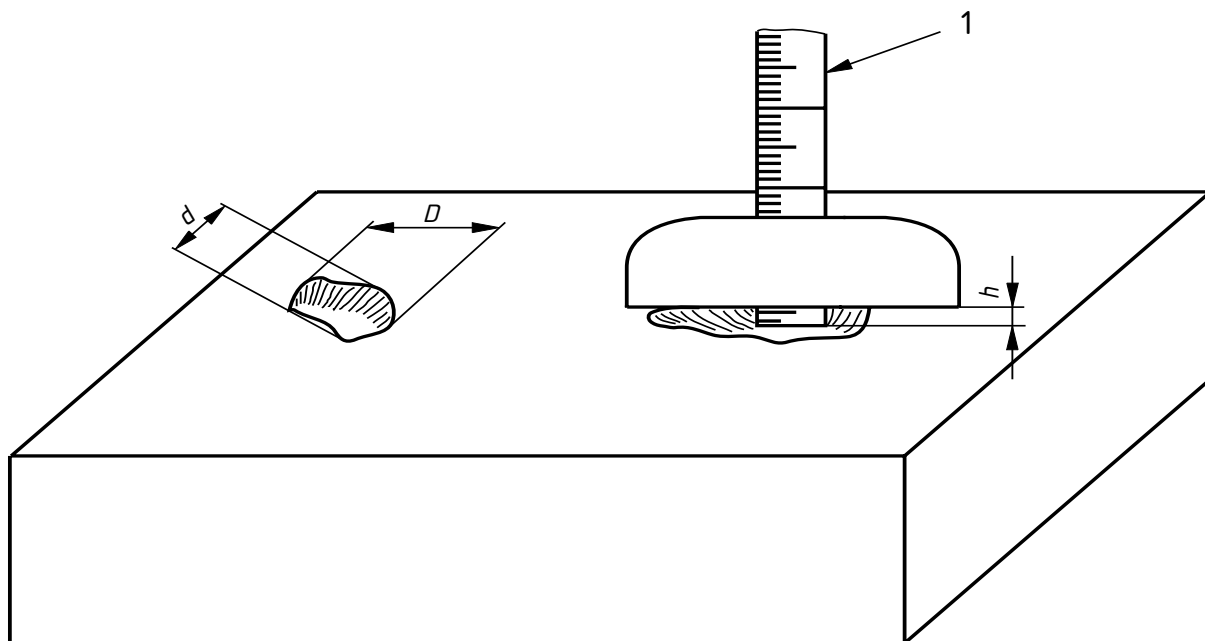

Key

- 1 Depth gauge \varnothing 3 mm
- D* Maximum diameter of a crater
- d* Minimum diameter of a crater
- h* Depth of a crater

Figure 12 — Measurement of craters and bubbles

6.8 Measurement of cracks

Measure the maximum visible width of a crack with a steel tape in one or more straight lines. If the crack continues on more than one surface, then the crack length is equal to the sum of the crack lengths on each surface.

Measure the width of a crack either with a graticule or with feeler gauges (see 5.4).

Table 1 — Accuracy of measurement

Measurement	Accuracy of measurement
Length of crack	1 mm
Width of open crack: between 0,2 mm and 1mm	0,2 mm
Width of open crack: greater than 1 mm	0,5 mm

Measure the dimensions of cracks to the accuracy given in Table 1. Surface crazing (see 3.5) shall be measured using a steel tape and reported in cm^2 .

6.9 Measurement of protrusions and indentations

Measure the height of a protrusion from the surface of the shape by means of a straightedge (see 5.2) and measuring wedges (see 5.3), to the nearest 0,5 mm. Place the straightedge parallel to the surface and in contact with the protrusion and adjust the measuring wedges so that equal readings are obtained on each of them, as indicated in Figure 13. Measure indentations using the same method as used for craters (see 6.7).

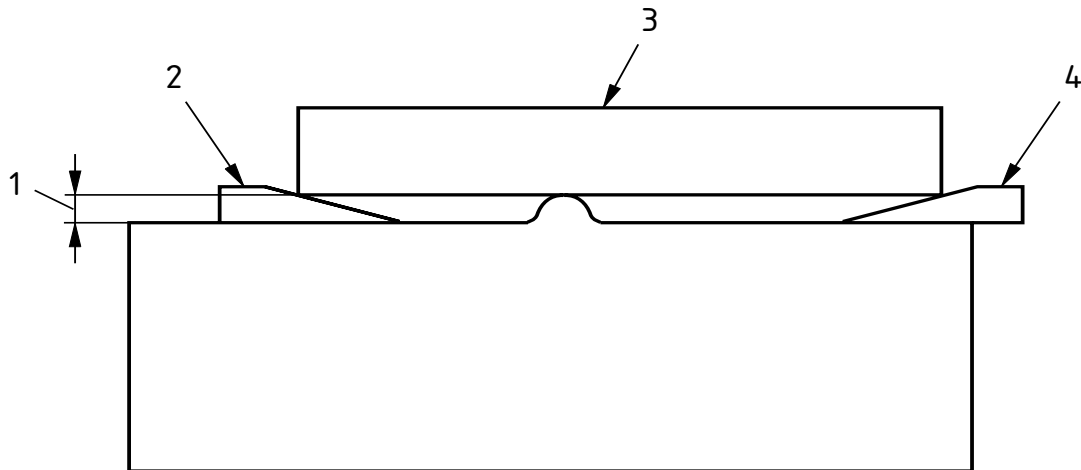

Key

- 1 Height
- 2 Measuring wedge
- 3 Straightedge
- 4 Measuring wedge

Figure 13 — Measurement of the height of a protrusion

6.10 Measurement of fins

Measure the height of fins to the nearest mm by depth gauge or steel tape.

6.11 Segregations

Measure the extent of the honeycombed structure using a linear measuring device. Measure dimensions to the nearest mm.

NOTE If possible, the extent of fines segregation should be measured using a linear measuring device.

6.12 Friability

For dense castables, measure the extent to which areas of a block can be rubbed away using hand pressure.

7 Inspection by variables

7.1 Destructive test methods

7.1.1 General

The position in the shape from where test pieces will be taken shall be agreed between parties and noted in the final report. If agreement cannot be reached or in the case of litigation the reference for the location of the sample will be the centre of the shape. If a wet cutting method has been used to obtain a test piece from a pre-formed shape, it shall be dried immediately following preparation.

7.1.2 Physical properties

Wherever possible, the dimensions and testing of test pieces cut from pre-formed shapes shall be in accordance with EN 1402-6. If this is not feasible, for example, if test pieces have to be cored or are of non standard dimensions, the test data will vary due to different test piece geometry.

NOTE The results obtained on testing a pre-formed shape will not equate to those obtained from a laboratory prepared test piece prepared according to EN 1402-5..

7.1.3 Moisture content (see NOTE 2 of 7.1.4)

Weigh the shape or test piece on an appropriate sized balance to the nearest 1 %, and dry it in a drying oven at $110\text{ °C} \pm 5\text{ °C}$ to constant mass.

Calculate the loss in mass, M , as a percentage of the original mass using the equation:

$$M = \frac{m_1 - m_2}{m_1} \cdot 100$$

where

M is the moisture content, as a percentage;

m_1 is the original mass in kilograms;

m_2 is the dried mass in kilograms.

7.1.4 Loss on ignition

Dry the shape or test piece at $110\text{ °C} \pm 5\text{ °C}$ until constant mass. Allow to cool to ambient temperature and weigh to the nearest 1 %, recording the mass as m_3 . Fire at $1\ 050\text{ °C} \pm 25\text{ °C}$ until constant mass. Allow to cool and weigh to the nearest 1 %, recording the mass as m_4 .

Calculate the loss on ignition, L_I , as a percentage of the final mass using the following equation:

$$L_I = \frac{m_3 - m_4}{m_3} \cdot 100$$

where

L_I is the loss on ignition, as a percentage;

m_3 is the mass after drying in kilograms;

m_4 is the final mass in kilograms.

NOTE 1 An intermediate temperature can be assigned for determining the loss on ignition. This temperature should be agreed between parties prior to testing and noted in the final report.

NOTE 2 If it is not possible to determine the moisture content or the loss on ignition on a full shape then a test piece should be obtained without using wet cutting methods, for example by breaking the shape to obtain a representative test piece.

7.2 Non-destructive test methods

7.2.1 Ultrasonic testing

7.2.1.1 General

Ultrasonic testing techniques do not give commonly accepted physical properties, but are used to determine an overall quality level. The methods employed are applied to pre-dried and cooled shapes at ambient temperature.

7.2.1.2 Principle

Propagation of ultrasonic waves through a test piece and determining their velocity.

NOTE Shapes with special geometry (e.g. tubes, plates) or with irregular geometry can give spurious results. In such cases the reliability of the measurement should be checked by preliminary testing. Wherever possible, the contact surface should be greater than the area of the sensor.

7.2.1.3 Testing equipment (see Figure 14)

7.2.1.3.1 Two identical low frequency sensors, (between 40 kHz and 100 kHz) with low damping rate. One sensor shall be the emitter and the other sensor shall be the receiver.

7.2.1.3.2 A suitable contact system as a couplant between the sensors and the test pieces, e.g. silicone grease and/or rubber disks.

If possible, use a clamping device to maintain the sensors in contact with the test piece.

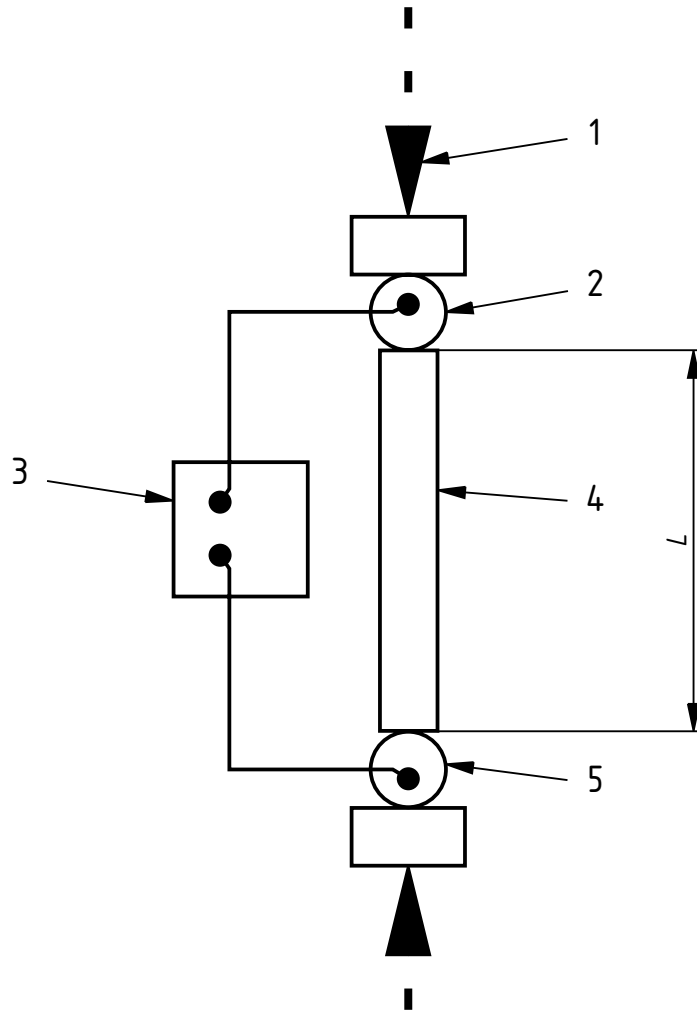

Key

- 1 System for moderate contact force
- 2 Transmitting transducer
- 3 Pulse transit timer
- 4 Test piece
- 5 Receiving transducer
- L Dimension along which the ultrasonic waves will be transmitted

Figure 14 — Block diagram of a suitable ultrasonic pulse velocity apparatus

7.2.1.4 Procedure

Measure, to within 0,5 mm, the dimension (L) along which the ultrasonic waves will be transmitted.

Calibrate the measuring apparatus with the calibration bar supplied by the manufacturer, or with an appropriate reference material, using the sensor couplant which will be used for the test.

Set the test piece between the sensors with the appropriate couplant in place.

Maintain the sensors in contact with the test piece at the points of measurement by hand pressure or using an appropriate device. Note the displayed propagation time. Repeat the test to check reproducibility. Recalibrate the apparatus when starting, every 50 measurements or when changing operators.

NOTE The number and direction of individual measurements on the test piece will depend on the test piece geometry.

7.2.1.5 Calculation

Calculate the ultrasonic propagation velocity, V in m/s, using the equation:

$$V = \frac{L}{t}$$

where

L is the dimension along the line of propagation in metres;

t is the propagation time in seconds.

7.2.1.6 Test report

The test report shall include the following information:

- a) the reference of the ultrasonic measurement apparatus and its characteristics;
- b) the reference and characteristics of the sensors;
- c) the type of contact system;
- d) individual and mean values of propagation velocity for each measurement direction.

7.2.2 Determination of the resonant frequency by mechanical shock

7.2.2.1 Principle

Excitation of a prismatic shape with an aspect ratio greater than 3 by mechanical shock and determination of its bending fundamental resonant frequency.

7.2.2.2 Testing equipment (see Figure 15)

7.2.2.2.1 Sensor, for the detection of the resonant frequency by contact (piezo electric pen) or without contact (microphone).

7.2.2.2.2 Impact hammer, (for example, a light hammer or screwdriver which has to be appropriate for the size and the hardness of the test piece).

7.2.2.2.3 Test piece support made from acoustically insulating material (for example, a layer of polyurethane foam, rubber prisms, or cylinders).

7.2.2.2.4 Acoustic insulating support, either a blanket of polyurethane foam, or two rubber bars with triangular or circular cross section set at a distance from the shape extremities equal to 0,224 multiplied by the length of the test piece.

To obtain reproducible results, the impact and signal receiving points shall be accurately determined.

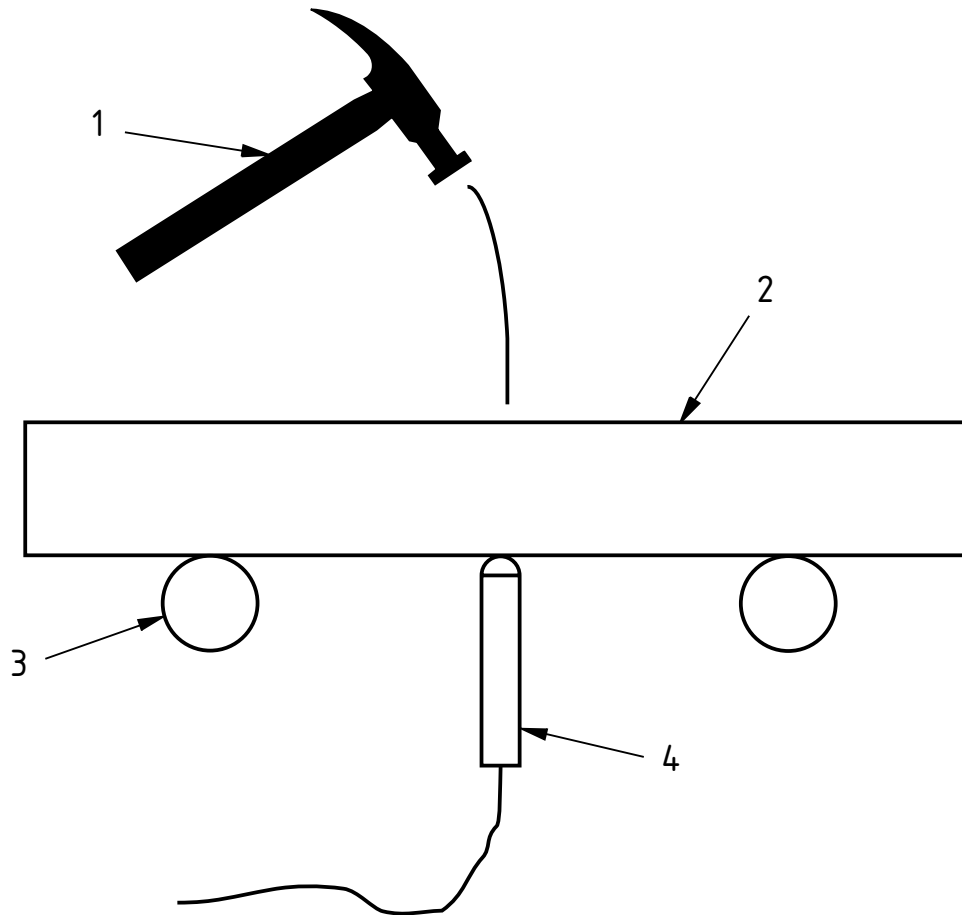

Key

- 1 Hammer
- 2 Shape or test piece
- 3 Rubber support
- 4 Microphone

Figure 15 — Block diagram of a suitable resonance frequency by mechanical shock apparatus

7.2.2.3 Procedure

Set the test piece on the acoustical insulating support.

Set the receiving sensor at the mid-length of the shape, taking into account the following considerations:

- if a piezoelectric pen is used, it shall be kept in contact with the centre of one of the largest sized faces;
- if a microphone is used, it shall be kept in contact with the centre of the lower face of the shape. In such a case the test piece shall be set on rubber prisms or cylinders.

Strike the centre of the upper face of the shape with a hammer and let it bounce freely. Note the reading displayed on the measuring apparatus. Repeat the measurement so as to obtain five corresponding values (the tolerance shall be defined with respect to the type of material and the size of the shape).

Report the mean of these five values, *S*.

7.2.2.4 Calculation

Calculate the resonant frequency, F in Hertz, using the equation:

$$F = \frac{2 \cdot 10^6}{t}$$

where

t is the mean of the five values read on the apparatus, in microseconds.

7.2.2.5 Test report

The test report shall include the following information:

- a) the geometry of the shapes tested;
- b) the reference of the measuring apparatus for resonant frequency and its characteristics;
- c) the nature and the characteristics of the receiving sensor;
- d) the nature of the supports;
- e) the nature of the striking hammer;
- f) impact and receiving points of the measurement;
- g) individual and mean values of the resonant frequency.

7.2.3 Rebound hammer

7.2.3.1 Principle

A steel hammer impinges with a predetermined amount of energy a steel plunger in contact with a surface of the shape and the distance that the hammer rebounds is measured.

7.2.3.2 Testing equipment

7.2.3.2.1 Rebound Hammer, consisting of a spring-loaded steel hammer which when released strikes a steel plunger in contact with the surface of the shape. The spring-loaded hammer shall travel with a consistent and reproducible velocity. The rebound distance of the steel hammer from the steel plunger is measured on a linear scale attached to the frame of the instrument.

7.2.3.2.2 Abrasive Stone, consisting of a medium grain textured silicon carbide or equivalent material.

7.2.3.2.3 Test Anvil, approximately 150 mm diameter by 150 mm high cylinder of high carbon tool steel with an impact area hardened to Rockwell 65 C to 67 C. An instrument guide is required to centre the rebound hammer over the impact area and keep the instrument perpendicular to the surface.

7.2.3.3 Test shapes

Shapes to be tested shall be at least 100 mm thick. Areas exhibiting honeycombing, scaling or high porosity shall be avoided.

A test area shall be at least 150 mm in diameter. Heavily textured, soft or loose surfaces shall be ground smooth with the abrasive stone.

7.2.3.4 Procedure

Hold the instrument firmly so that the plunger is perpendicular to the test surface. Gradually push the instrument towards the test surface until the hammer strikes. After impact, maintain pressure on the instrument and, if necessary, depress the button on the side of the instrument to lock the plunger in its retracted position. Estimate the rebound number on the scale to the nearest whole number. Take ten readings from each test area. No two impact tests shall be closer than 25 mm. Examine the impression made on the surface of the shape after impact, and if the impact crushes or breaks through a surface void disregard the reading and take another.

7.2.3.5 Test report

The test report shall contain the following information:

- a) location of the area tested on the shape;
- b) description of test area including surface characteristics;
- c) if surface was ground and depth of grinding;
- d) hammer identification and serial number;
- e) orientation of hammer during test;
- f) average rebound number for test area.

7.2.4 Mass

Weigh the shape to of the nearest 1 % on an appropriate sized balance.

7.2.5 Bulk density

Calculate the geometric bulk density, ρ_g in kilograms per cubic metre, using the equation:

$$\rho_g = \frac{m}{V}$$

where

m is the mass of the shape as determined in 7.2.4, in kilograms.

V is the volume of the shape obtained by calculation using the mean dimensions as determined in 6.2, in cubic metres.

Express the result to the nearest 1 %.

8 Test report

The test report shall contain the following information:

- a) all information necessary for identification of the sample tested, including the designation of the pre-formed shapes tested (manufacturer, type, shape, date of forming, batch number and, if applicable, any thermal pre-treatment);
- b) a reference to this European Standard, i.e. EN 1402-7;
- c) the methods used and the properties inspected;

- d) the number of items tested;
- e) if test pieces have been taken, the number and location in the pre-formed shape;
- f) the results of the tests, including the results of the individual determinations and their means, calculated as specified in clauses 6 and 7, and including extra information specified in those clauses;
- g) any deviations from the procedure specified;
- h) any unusual features (anomalies) observed during the test;
- i) the name of the testing establishment;
- a) date of the test.

Bibliography

EN 1402-3, *Unshaped refractory products - Part 3: Characterization as received.*

EN 1402-5, *Unshaped refractory products - Part 5: Preparation and treatment of test pieces.*

ISO 12678-1, *Refractory products - Measurement of dimensions and external defects of refractory bricks - Part 1: Dimensions and conformity to drawings.*

ISO 12678-2, *Refractory products - Measurement of dimensions and external defects of refractory bricks - Part 2: Corner and edge defects and other surface imperfections.*

BSI — British Standards Institution

BSI is the independent national body responsible for preparing British Standards. It presents the UK view on standards in Europe and at the international level. It is incorporated by Royal Charter.

Revisions

British Standards are updated by amendment or revision. Users of British Standards should make sure that they possess the latest amendments or editions.

It is the constant aim of BSI to improve the quality of our products and services. We would be grateful if anyone finding an inaccuracy or ambiguity while using this British Standard would inform the Secretary of the technical committee responsible, the identity of which can be found on the inside front cover.
Tel: +44 (0)20 8996 9000. Fax: +44 (0)20 8996 7400.

BSI offers members an individual updating service called PLUS which ensures that subscribers automatically receive the latest editions of standards.

Buying standards

Orders for all BSI, international and foreign standards publications should be addressed to Customer Services. Tel: +44 (0)20 8996 9001.
Fax: +44 (0)20 8996 7001. Email: orders@bsi-global.com. Standards are also available from the BSI website at <http://www.bsi-global.com>.

In response to orders for international standards, it is BSI policy to supply the BSI implementation of those that have been published as British Standards, unless otherwise requested.

Information on standards

BSI provides a wide range of information on national, European and international standards through its Library and its Technical Help to Exporters Service. Various BSI electronic information services are also available which give details on all its products and services. Contact the Information Centre.
Tel: +44 (0)20 8996 7111. Fax: +44 (0)20 8996 7048. Email: info@bsi-global.com.

Subscribing members of BSI are kept up to date with standards developments and receive substantial discounts on the purchase price of standards. For details of these and other benefits contact Membership Administration.
Tel: +44 (0)20 8996 7002. Fax: +44 (0)20 8996 7001.
Email: membership@bsi-global.com.

Information regarding online access to British Standards via British Standards Online can be found at <http://www.bsi-global.com/bsonline>.

Further information about BSI is available on the BSI website at <http://www.bsi-global.com>.

Copyright

Copyright subsists in all BSI publications. BSI also holds the copyright, in the UK, of the publications of the international standardization bodies. Except as permitted under the Copyright, Designs and Patents Act 1988 no extract may be reproduced, stored in a retrieval system or transmitted in any form or by any means – electronic, photocopying, recording or otherwise – without prior written permission from BSI.

This does not preclude the free use, in the course of implementing the standard, of necessary details such as symbols, and size, type or grade designations. If these details are to be used for any other purpose than implementation then the prior written permission of BSI must be obtained.

Details and advice can be obtained from the Copyright & Licensing Manager.
Tel: +44 (0)20 8996 7070. Fax: +44 (0)20 8996 7553.
Email: copyright@bsi-global.com.