

BS EN 1317-1:2010



BSI Standards Publication

Road restraint systems

Part 1: Terminology and general criteria for test methods

bsi.

...making excellence a habit.™

National foreword

This British Standard is the UK implementation of EN 1317-1:2010. It supersedes BS EN 1317-1:1998 which is withdrawn.

The UK participation in its preparation was entrusted to Technical Committee B/509/1, Road restraint systems.

A list of organizations represented on this committee can be obtained on request to its secretary.

This publication does not purport to include all the necessary provisions of a contract. Users are responsible for its correct application.

© BSI 2010

ISBN 978 0 580 54025 7

ICS 01.040.13; 01.040.93; 13.200; 93.080.30

Compliance with a British Standard cannot confer immunity from legal obligations.

This British Standard was published under the authority of the Standards Policy and Strategy Committee on 31 August 2010.

Amendments issued since publication

Date	Text affected
------	---------------

EUROPEAN STANDARD

EN 1317-1

NORME EUROPÉENNE

EUROPÄISCHE NORM

July 2010

ICS 01.040.93; 93.080.30

Supersedes EN 1317-1:1998

English Version

Road restraint systems - Part 1: Terminology and general criteria for test methods

Dispositifs de retenue routiers - Partie 1 : Terminologie et dispositions générales pour les méthodes d'essai

Rückhaltesysteme an Straßen - Teil 1: Terminologie und allgemeine Kriterien für Prüfverfahren

This European Standard was approved by CEN on 29 April 2010.

CEN members are bound to comply with the CEN/CENELEC Internal Regulations which stipulate the conditions for giving this European Standard the status of a national standard without any alteration. Up-to-date lists and bibliographical references concerning such national standards may be obtained on application to the CEN Management Centre or to any CEN member.

This European Standard exists in three official versions (English, French, German). A version in any other language made by translation under the responsibility of a CEN member into its own language and notified to the CEN Management Centre has the same status as the official versions.

CEN members are the national standards bodies of Austria, Belgium, Bulgaria, Croatia, Cyprus, Czech Republic, Denmark, Estonia, Finland, France, Germany, Greece, Hungary, Iceland, Ireland, Italy, Latvia, Lithuania, Luxembourg, Malta, Netherlands, Norway, Poland, Portugal, Romania, Slovakia, Slovenia, Spain, Sweden, Switzerland and United Kingdom.



EUROPEAN COMMITTEE FOR STANDARDIZATION
COMITÉ EUROPÉEN DE NORMALISATION
EUROPÄISCHES KOMITEE FÜR NORMUNG

Management Centre: Avenue Marnix 17, B-1000 Brussels

Contents

Page

Foreword.....	3
Introduction	5
1 Scope	6
2 Normative references	6
3 Abbreviations	6
4 Terms and definitions	7
5 Test methods.....	10
5.1 Test site	10
5.2 Test vehicles	11
5.2.1 General.....	11
5.2.2 Loading conditions.....	11
6 Vehicle Instrumentation	13
6.1 Vehicle Instrumentation required for the calculation of ASI and THIV	13
6.2 Frequency requirements.....	13
6.3 Compensation for instrumentation displaced from the vehicle centre of mass.....	13
7 Data Processing and Analysis	15
8 Test Results and Calculations.....	17
8.1 Severity Indices.....	17
8.1.1 General.....	17
8.1.2 Summary of the procedure to compute ASI	17
8.1.3 Procedure to compute THIV	18
8.2 Vehicle cockpit deformation index (VCDI)	24
8.2.1 Deformation	24
8.2.2 Location of the deformation	24
8.2.3 Extent of the deformation	25
8.2.4 Examples (informative)	27
Annex A (informative) Calculation of the acceleration severity index (ASI)	28
Annex B (informative) Vehicle acceleration - Measurement and calculation methods	29
B.1 Introduction	29
B.2 Acceleration in a rigid body.....	29
B.3 Methods of measuring rigid body motion	30
B.4 Measurement by six linear and three angular transducers.....	31
B.5 Remarks	35
Bibliography	36

Foreword

This document (EN 1317-1:2010) has been prepared by Technical Committee CEN/TC 226 “Road equipment”, the secretariat of which is held by AFNOR.

This European Standard shall be given the status of a national standard, either by publication of an identical text or by endorsement, at the latest by January 2011, and conflicting national standards shall be withdrawn at the latest by January 2011.

Attention is drawn to the possibility that some of the elements of this document may be the subject of patent rights. CEN [and/or CENELEC] shall not be held responsible for identifying any or all such patent rights.

This document supersedes EN 1317-1:1998.

This document has been prepared under a mandate given to CEN by the European Commission and the European Free Trade Association, and supports essential requirements of EU Directive(s).

EN 1317 consists of the following parts:

- EN 1317-1, *Road restraint systems — Part 1: Terminology and general criteria for test methods*;
- EN 1317-2, *Road restraint systems — Part 2: Performance classes, impact test acceptance criteria and test methods for safety barriers including vehicle parapets*;
- EN 1317-3, *Road restraint systems — Part 3: Performance classes, impact test acceptance criteria and test methods for crash cushions*;
- ENV 1317-4, *Road restraint systems — Part 4: Performance classes, impact test acceptance criteria and test methods for terminals and transitions of safety barriers*;
- prEN 1317-4, *Road restraint systems — Part 4: Performance classes, impact test acceptance criteria and test methods for transitions of safety barriers* (under preparation: this document will supersede ENV 1317-4:2001 for the clauses concerning transitions);
- EN 1317-5, *Road restraint systems — Part 5: Product requirements and evaluation of conformity for vehicle restraint systems*;
- prEN 1317-6, *Road restraint systems — Pedestrian restraint systems — Part 6: Pedestrian Parapet* (under preparation);
- prEN 1317-7, *Road restraint systems — Part 7: Performance classes, impact test acceptance criteria and test methods for terminals of safety barriers* (under preparation: this document will supersede ENV 1317-4:2001 for the clauses concerning terminals);
- prEN 1317-8, *Road restraint systems — Part 8: Motorcycle road restraint systems which reduce the impact severity of motorcyclist collisions with safety barriers* (under preparation).

Annexes A and B are informative.

The significant technical changes incorporated in this revision are:

5 Test methods

The specifications for the test site and test vehicles have been moved from Parts 2 and 3 to Part 1.

6.1 Vehicle instrumentation required for the calculation of ASI and THIV

The requirement of the 1998 text:

Vehicle acceleration shall be measured at a single point (P) within the vehicle body close to the vehicle centre of gravity.

is replaced by:

The accelerometers shall be mounted at a single point (P) on the tunnel close to the vertical projection of vehicle centre of mass of the undeformed vehicle, but no further than 70 mm longitudinally and 40 mm laterally. Measurements made before the publication of the present standard, with accelerometers fixed to an installation close to the centre of mass are accepted.

6.2 Frequency requirements

The following new requirement has been introduced:

Since the data will be filtered by recursive (Butterworth) filters, more data should be collected than is specifically required by the analysis. A recursive filter always produces "starting transients" at the beginning and end of the data, and requires time to "settle down". An additional 500 ms of data shall be collected at the beginning and end of the data; this extra data can then be discarded after filtering.

6.3 Compensation for instrumentation displaced from the vehicle centre of mass

The procedure has been extended also to the cases of non-null roll angle and roll velocity and when the three points Q₁, Q₂, P (P₁, P₂, P in the 1998 text) are aligned along any straight line.

8.1 Severity Indices

The requirement for the index PHD (Post impact Head Deceleration) has been removed. ASI and THIV are required.

8.1.1 Summary of the procedure to compute ASI

In the procedure to compute ASI, averaging of the three components of the acceleration over a moving window of 50 ms has been replaced by filtering with a four-pole phaseless Butterworth digital filter.

8.2 Vehicle cockpit deformation index (VCDI)

8.2.2 Location of the deformation

The prefix 'ND' has been added for impacts where there is no deformation of the vehicle cockpit.

8.2.3 Extent of the deformation

"The sub-index 3 has been added for reductions greater than 20 %, or measurements which cannot be taken due to the deformation of the vehicle."

According to the CEN/CENELEC Internal Regulations, the national standards organizations of the following countries are bound to implement this European Standard: Austria, Belgium, Bulgaria, Croatia, Cyprus, Czech Republic, Denmark, Estonia, Finland, France, Germany, Greece, Hungary, Iceland, Ireland, Italy, Latvia, Lithuania, Luxembourg, Malta, Netherlands, Norway, Poland, Portugal, Romania, Slovakia, Slovenia, Spain, Sweden, Switzerland and the United Kingdom.

Introduction

In order to improve and maintain highway safety, the design of safer roads requires, on certain sections of road and at particular locations, the installation of road restraint systems. These road systems are designated to redirect errant vehicles with a specified performance level and can provide guidance for pedestrians or other road users.

This European Standard is a revision of EN 1317-1:1998. The standard identifies test methods and impact test acceptance criteria that the products for road restraint systems need to meet to demonstrate compliance with the requirements, given in EN 1317-5 and/or prEN 1317-6. The design specification, for road restraint systems entered in the test report, identify important functional site conditions in respect of the test installation.

The performance range of the products for road restraint systems, designated in this standard, enables national and local authorities to recognize and specify the performance class to be deployed.

Annexes A and B give informative explanation of the measurement of the severity index ASI and vehicle acceleration.

1 Scope

This European Standard contains provisions for the measurement of performance of products for the road restraint systems, under impact and impact severity levels, and includes:

- Test site data;
- Definitions for road restraint systems;
- Vehicle specification (including loading requirements) for vehicles used in the impact tests;
- Instrumentation for the vehicles;
- Calculation procedures and methods of recording crash impact data including impact severity levels;
- VCDI.

The modifications included in this standard are not a change of test criteria, in the sense of EN 1317-5:2007+A1:2008, ZA.3.

2 Normative references

The following referenced documents are indispensable for the application of this document. For dated references, only the edition cited applies. For undated references, the latest edition of the referenced document (including any amendments) applies.

EN 1317-2, *Road restraint systems — Part 2: Performance classes, impact test acceptance criteria and test methods for safety barriers including vehicle parapets*

EN 1317-3, *Road restraint systems — Part 3: Performance classes, impact test acceptance criteria and test methods for crash cushions*

ENV 1317-4, *Road restraint systems — Part 4: Performance classes, impact test acceptance criteria and test methods for terminals and transitions of safety barriers*

ISO 6487, *Road vehicles — Measurement techniques in impact tests — Instrumentation*

ISO 10392, *Road vehicles with two axles — Determination of centre of gravity*

3 Abbreviations

ASI:	Acceleration Severity Index
ATD:	Anthropomorphic Test Device
CAC:	Channel Amplitude Class
CFC:	Channel Frequency Class
COG:	Centre of mass
HGV:	Heavy Goods Vehicle
PRS:	Pedestrian Restraint System

RRS:	Road Restraint System
THIV:	Theoretical Head Impact Velocity
VCDI:	Vehicle Cockpit Deformation Index
VRS:	Vehicle Restraint System

4 Terms and definitions

The types of system are shown in Figure 1.

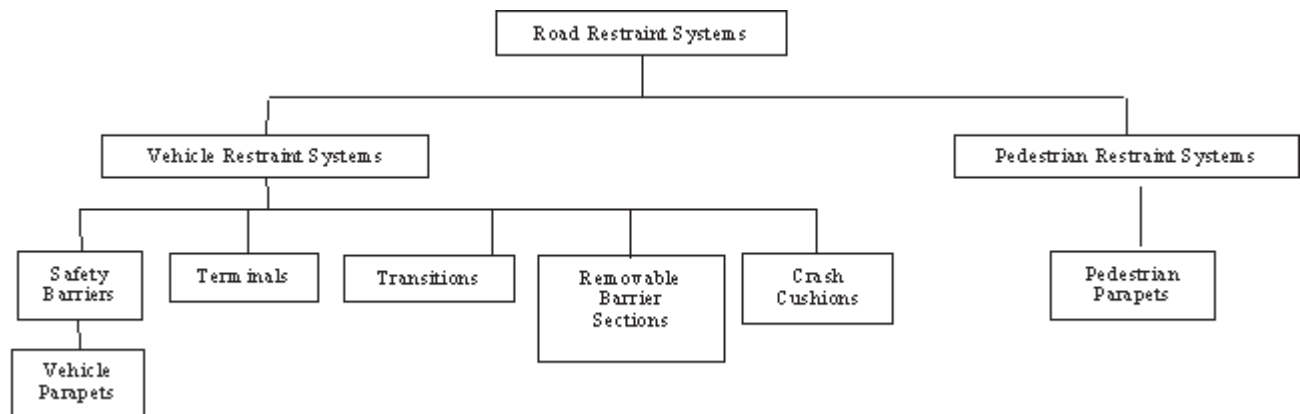

Figure 1 — Types of system

For the purposes of this document, the following terms and definitions apply.

4.1

road restraint system

vehicle restraint system and pedestrian restraint system used on the road

4.2

vehicle restraint system

system installed on the road to provide a level of containment for an errant vehicle

4.3

safety barrier

continuous vehicle restraint system installed alongside, or on the central reserve, of a road

NOTE This can include a vehicle parapet.

4.4

terminal

end treatment of a safety barrier

4.5

transition

connection of two safety barriers of different designs and/or performances

4.6

vehicle parapet

safety barrier installed on the side of a bridge or on a retaining wall or similar structure where there is a vertical drop and which can include additional protection and restraint for pedestrians and other road users (combined vehicle/pedestrian parapet)

4.7

crash cushion

road vehicle energy absorption device installed in front of one or more hazards to reduce the severity of impact

4.8

pedestrian restraint system

system installed to provide restraint for pedestrians

4.9

pedestrian parapet

pedestrian or "other user" restraint system along the edge of a footway or footpath intended to restrain pedestrians and other users from stepping onto or crossing a road or other area likely to be hazardous

NOTE "Other users" include provision for equestrians, cyclists and livestock.

4.10

kerb mass

vehicle as delivered, including all fluids

4.11

test inertial mass

kerb mass plus ballast and recording and brake equipment but excluding dummy

4.12

total mass

mass that includes all items in the test vehicle at the beginning of the test

4.13

combined vehicle/pedestrian parapet

vehicle parapet with additional safety provisions for pedestrians and/or other road users

4.14

wheel base

distance between the centres of tyre contact of the two wheels on the same side of the vehicle, projected onto the longitudinal centreline of the vehicle

NOTE For vehicles with more than two axles, the wheel bases between extreme axles.

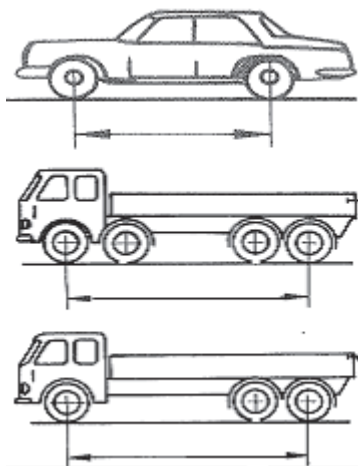

Figure 2 — Examples of wheel base

4.15

wheel track

distance between the centre of tyre contact of the two wheels of an axle, projected on to the YZ plane

NOTE In the case of dual wheels, it is the point centrally located between the centres of tyre contact of the two wheels of the dual axle.

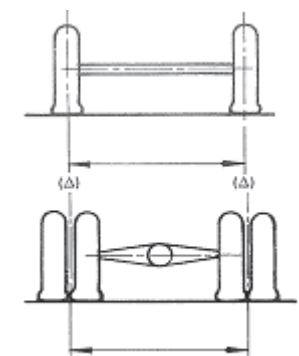

Figure 3 — Examples of wheel track

4.16

centre of tyre contact

P centre of tyre contact (or central plane between two tyres for dual axle vehicles)

NOTE See Figure 4.

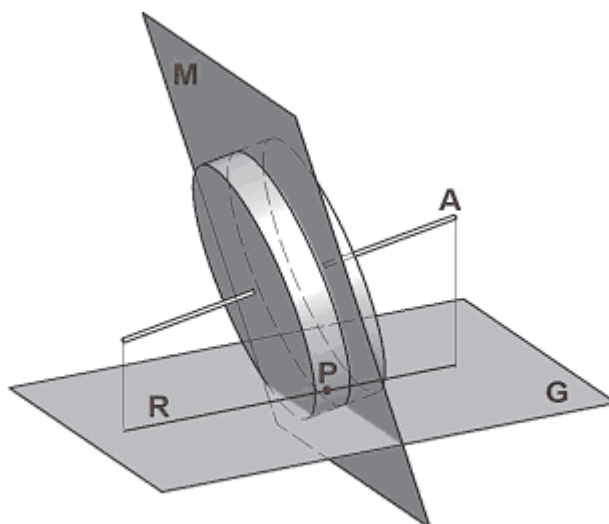

Key

- A Wheel Spin Axis
- G Ground Plane
- M Wheel Mid Plane
- R Projection of A on G
- P Centre of Tyre Contract

Figure 4 — Centre of tyre contact

4.17 anthropomorphic test device

anthropomorphic device representative of a 50th percentile adult male, specifically designed to represent in form, size and mass, a vehicle occupant, and to reproduce the dynamic behaviour of an occupant in crash testing

4.18 removable barrier section

section of a barrier connected at both ends to permanent barriers in order to be removed or displaced wholly or in parts that allows a horizontal opening to be provided

4.19 pre-tensioned system

main longitudinal element(s) of a barrier pre-tensioned to obtain the design performance

5 Test methods

5.1 Test site

The vehicle approach and exit box areas shall be generally flat with a gradient not exceeding 2,5 %. It shall have a level hardened paved surface and shall be clear of dust, debris, standing water, ice or snow at the time of the test. It shall be of sufficient size to enable the test vehicle to be accelerated up to the required speed and controlled so that its approach to and exit from the vehicle restraint system is stable.

Dimensioned sketch plan(s) of the test area shall be included in the test report which shall show the testing area including the road restraint product tested, position of all cameras, path of the vehicle, impact point and the dimensioned locations for all test item parts exceeding 2,0 kg that broke away during the test. For tests which have been performed prior to EN 1317-1:2010, such dimensioned sketch plans are not obligatory.

During certain tests, such as a vehicle parapet test, where a bridge deck installation is used, the test vehicle and/or barrier shall not in any way touch or take advantage of structures which will not be present on the final bridge installation; i.e. if the vehicle drops down behind the bridge installation, it shall not touch soil or supporting devices.

The dimensions of the edge detail shall be sufficient to demonstrate the actual performance of the vehicle and the tested system on the edge of a bridge, or structure.

The test shall demonstrate the minimum width of structure behind the traffic face of the vehicle parapet that is required to safely contain and redirect the vehicle.

For tests in accordance with EN 1317-2, EN 1317-3 or ENV 1317-4, the paved area shall be sufficient to allow the vehicle exit characteristics to be evaluated.

Appropriate measures shall be taken in order to minimise dust generation from the test area and the test vehicle during the impact test so that photographic records will not be obscured.

Appropriate measures shall be taken to ensure that in the exit area the test vehicle does not collide with any independent obstruction which could cause additional deformation of the test vehicle thereby precluding the accurate measurement of the vehicle cockpit deformation index (VCDI) (see 8.2).

Foundations, anchorages and fixings shall perform according to the design of the vehicle restraint system. The vehicle restraint system's manufacturer shall provide details of the maximum forces which can be transmitted by anchorages to the foundation. Such maximum forces shall be those generated at the ultimate failure of the vehicle restraint system including vehicle parapet by any conceivable impact, and shall normally be greater than those that can be measured during the impact. Hence the ultimate forces which can be transmitted to the bridge deck shall be obtained by calculations or by ad-hoc tests.

The forces on anchorages or on the bridge may be measured during the test and reported in 5.2 of the test report.

5.2 Test vehicles

5.2.1 General

The vehicles to be used in the tests shall be production models and, for vehicles up to and including 1 500 kg, shall be representative of current traffic in Europe. All vehicles used for impact testing to this standard shall have characteristics and dimensions within the vehicle specifications defined in Table 1.

The tyres shall be inflated to the vehicle manufacturer's recommended pressures. The condition of the vehicle shall satisfy the requirements for the issue of a vehicle certificate of road worthiness with respect to tyres, suspension, wheel alignment and bodywork. No repairs or modifications, including reinforcement, shall be made that would alter the general characteristics of the vehicle or invalidate such a certification. Any repairs shall conform to the original vehicle specification as defined by the vehicle manufacturer. The vehicle shall be clean and mud or deposits, which may cause dust on impact shall be removed prior to testing. Marker points shall be placed on external surfaces of the test vehicle to aid analysis.

The vehicle shall not be restrained by the control of the steering or any other means during impact and whilst the vehicle is in the exit area (e.g. engine power, braking, anti lock brakes, blocking or fixing).

5.2.2 Loading conditions

All fluids shall be included in the test inertial mass.

All ballast weights shall be securely fixed to the vehicle in such a way as not to exceed the manufacturer's specifications for distribution of weight in the horizontal and vertical planes.

Ballast weights shall not be fixed in locations, which would modify the deformation of, or intrusions into, the vehicle.

The permissible axle weights of the vehicles shall not be exceeded when loaded.

Vehicle specifications under test conditions shall be as specified in Table 1.

Table 1 — Vehicle specifications

MASS kg ±								
Total mass	900 ± 40	1 300 ± 65	1 500 ± 75	10 000 ± 300	13 000 ± 400	16 000 ± 500	30 000 ± 900	38 000 ± 1 100
Test inertial mass ^a	825 ± 40	1 300 ± 65	1 500 ± 75	10 000 ± 300	13 000 ± 400	16 000 ± 500	30 000 ± 900	38 000 ± 1 100
Including maximum ballast ^b	100	160	180	Not applicable	Not applicable	Not applicable	Not applicable	Not applicable
ATD installed	78 ± 4	Not required	Not required	Not required	Not required	Not required	Not required	Not required
DIMENSIONS m (Limit deviation ± 15 %)								
Wheel track (front and rear)	1,35	1,40	1,50	2,00	2,00	2,00	2,00	2,00
Wheel radius (unloaded)	Not applicable	Not applicable	Not applicable	0,46	0,52	0,52	0,55	0,55
Wheel base (between extreme axles)	Not applicable	Not applicable	Not applicable	4,60	6,50	5,90	6,70	11,25
CENTRE OF MASS LOCATION^{c d} m								
Longitudinal distance from front axle (CGX) ± 10 %	0,90	1,10	1,24	2,70	3,80	3,10	4,14	6,20
Lateral distance from vehicle centre line (CGY)	± 0,07	± 0,07	± 0,08	± 0,10	± 0,10	± 0,10	± 0,10	± 0,10
Height above ground (CGZ):								
— Vehicle mass (± 10 %)	0,49	0,53	0,53	Not applicable	Not applicable	Not applicable	Not applicable	Not applicable
— Load (+ 15 %, - 5 %)	Not applicable	Not applicable	Not applicable	1,50	1,40	1,60	1,90	1,90
TYPE OF VEHICLE	Car	Car	Car	Rigid HGV	Bus	Rigid HGV	Rigid HGV	Articulated HGV
Number of axles ^e	1S + 1	1S + 1	1S + 1	1S + 1	1S + 1	1S + 1/2	2S + 2	1S + 3/4
^a	Including load for heavy goods vehicles (HGV).							
^b	Including measuring and recording equipment.							
^c	The vehicle's centre of mass shall be determined when the ATD is not in the car.							
^d	The centre of mass of vehicles with two axles shall be determined in conformity with ISO 10392.							
^e	S: steering axle.							

6 Vehicle Instrumentation

6.1 Vehicle Instrumentation required for the calculation of ASI and THIV

The vehicle shall be fitted with, as a minimum, one accelerometer for measurement in the longitudinal (forward) direction, one for the lateral (sideways) direction, one for the vertical direction (downward) and optionally an angular velocity sensor (rate sensor). The accelerometers shall be mounted at a single point (P) on the tunnel close to the vertical projection of vehicle centre of mass of the undeformed vehicle, but no further than 70 mm longitudinally and 40 mm laterally from the centre of mass.

Measurements made before EN 1317-1:2010, with accelerometers fixed to an installation close to the centre of mass are accepted.

Experience shows that, due to physical constraints, the actual placement of the set of accelerometers may be offset more than 70 mm from the centre of mass; then, significant differences can occur between measured accelerations and those at the centre of mass, due to angular motions. In these cases a second set of accelerometers shall be placed along the longitudinal axis and the process outlined in 6.3 shall be implemented.

Yaw angle shall be measured within a tolerance of $\pm 4^\circ$, by integration of yaw rate or by other means. The sampling interval shall not exceed 50 ms. The yaw rate sensor shall be mounted in any rigid location, since the angular rates are the same in any point of a rigid body.

6.2 Frequency requirements

The transducers, filters and recording channels shall comply with the frequency class specified in Clause 7; that is a frequency class of CFC_180 for acceleration and angular velocity channels. (Data filtered to CFC_60 may be used for graphical plotting of acceleration data.) They shall also conform to ISO 6487.

This filter specification implies that the data shall be sampled at a sampling interval of at least 2 kHz.

Since the data will be filtered by recursive (Butterworth) filters, more data should be collected than is specifically required by the analysis. A recursive filter always produces "starting transients" at the beginning and end of the data, and requires time to "settle down". An additional 500 ms of data shall be collected at the beginning and end of the data; this extra data can then be discarded after filtering.

As well as specifying the sampling rate and filter frequency, the channel amplitude class (CAC) for each of the accelerometers and the rate gyro shall be specified, to ensure that the outputs from transducers and the recording system are not "clipped", while still producing maxima which are a reasonable fraction of "full scale", to avoid excessive "quantisation" in the digitising process. Suitable values of CAC shall be selected after inspection of a range of test data and reported in the test report.

An event indicator shall be used to signal the moment of first vehicle contact with the vehicle restraint system.

6.3 Compensation for instrumentation displaced from the vehicle centre of mass

Vehicular accelerations shall be used in the assessment of test results through ASI, THIV and the flail space model. The set of accelerometers should be placed as close as possible to the vehicle centre of mass (point P) but no further than 70 mm longitudinally and 40 mm laterally from the centre of mass. However experience shows that this cannot always be done, due to physical constraints within the vehicle. As a result, actual placement of the set of accelerometers can be offset more than 70 mm from the centre of mass; then, depending on the offset, significant differences can occur between measured accelerations and those at the centre of mass, due to angular motions.

These differences can be minimized by the use of additional instrumentation. Therefore in addition to the basic set of three accelerometers, a second tri-axial set shall be placed along the x (longitudinal) axis, as shown in Figure 5.

With reference to Figure 5, point Q is located along the x axis at a distance x from point P (close to the centre of mass). Following the sign convention in Figure 5, x is positive if point Q is forward of the centre of mass, and negative if it is behind.

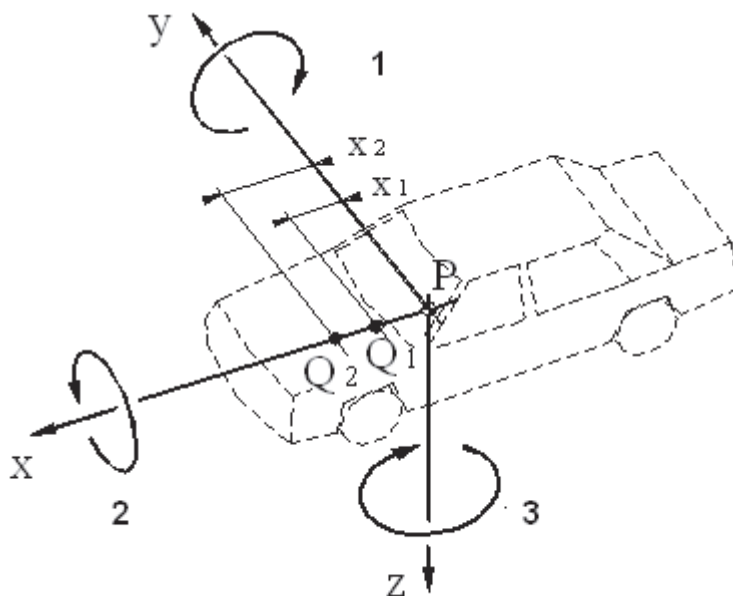

- Key**
- 1 pitch
 - 2 roll
 - 3 yaw

Figure 5 — Positive sign convention and accelerometer location

$$a_{xQ} = a_{xP} - x(\omega_y^2 + \omega_z^2)$$

$$a_{yQ} = a_{yP} + x(\dot{\omega}_z + \omega_x \omega_y) \tag{1}$$

$$a_{zQ} = a_{zP} - x(\dot{\omega}_y - \omega_x \omega_z)$$

where

a_{xQ}, a_{yQ}, a_{zQ} are the longitudinal, lateral, and vertical accelerations of point Q;

a_{xP}, a_{yP}, a_{zP} are the longitudinal, lateral and vertical accelerations of the point P (origin of co-ordinate system);

$\omega_x, \omega_y, \omega_z$ are the roll, pitch and yaw rates (Equation (1) holds if P and Q are points of a rigid body and if point Q is on the x axis).

If two different points, Q_1 and Q_2 , are defined at different locations on the x axis, and the quantities measured at these points are given the subscripts 1 and 2 respectively, then the accelerations at these points shall be given by:

$$a_{x1} = a_{xP} - x_1(\omega_y^2 + \omega_z^2)$$

$$\begin{aligned}
 a_{x2} &= a_{xP} - x_2(\dot{\omega}_y^2 + \omega_z^2) \\
 a_{y1} &= a_{yP} + x_1(\dot{\omega}_z + \omega_x\omega_y) \\
 a_{y2} &= a_{yP} + x_2(\dot{\omega}_z + \omega_x\omega_y) \\
 a_{z1} &= a_{zP} - x_1(\dot{\omega}_y - \omega_x\omega_z) \\
 a_{z2} &= a_{zP} - x_2(\dot{\omega}_y - \omega_x\omega_z)
 \end{aligned}
 \tag{2}$$

From Equation (2) the accelerations of the point P shall be computed as follows:

$$\begin{aligned}
 a_{xP} &= \frac{x_1a_{x2} - x_2a_{x1}}{x_1 - x_2} \\
 a_{yP} &= \frac{x_1a_{y2} - x_2a_{y1}}{x_1 - x_2} \\
 a_{zP} &= \frac{x_1a_{z2} - x_2a_{z1}}{x_1 - x_2}
 \end{aligned}
 \tag{3}$$

NOTE Equation (1) is valid for any orientation of the x axis, hence Equation (3) applies only if the three points P, Q₁ and Q₂ belong to the same straight line in any direction.

7 Data Processing and Analysis

The raw test data recorded using the instrumentation prescribed within Clause 6 shall be processed using the procedures given in Figure 6.

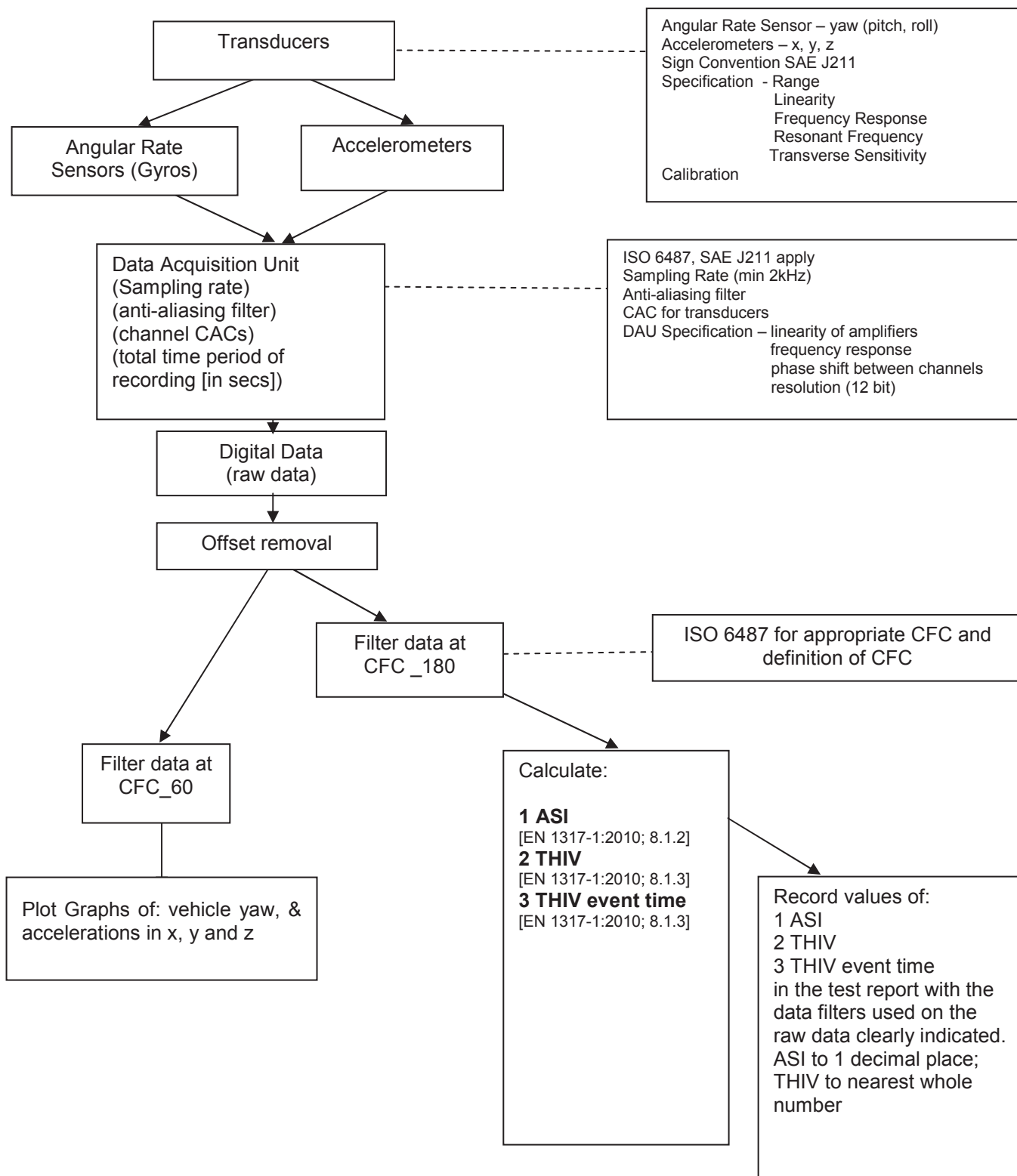

Figure 6 — Data Processing Flow Diagram

Data recorded during the last 6 m of vehicle travel before the initial impact with the VRS shall be used to determine the offset removal. The mean average of at least 100 consecutive samples shall be taken from this data set.

8 Test Results and Calculations

8.1 Severity Indices

8.1.1 General

Severity indices ASI and THIV shall be computed using the vehicle instrumentation as specified in 6.1 and 6.2 and by following the procedures in 8.1.2 and 8.1.3. These values shall be quoted in the test report.

8.1.2 Summary of the procedure to compute ASI

- a) Record the measures of the three components A_x , A_y , A_z of vehicle acceleration with the prescribed instrumentation.

In general such measures are stored on a magnetic support media, as three series of N numbers, sampled at a certain sampling rate S (samples per second).

For three such measurement series:

$$A_x(1), A_x(2), \dots, A_x(k-1), A_x(k), A_x(k+1), \dots, A_x(N)$$

$$A_y(1), A_y(2), \dots, A_y(k-1), A_y(k), A_y(k+1), \dots, A_y(N)$$

$$A_z(1), A_z(2), \dots, A_z(k-1), A_z(k), A_z(k+1), \dots, A_z(N)$$

the acceleration of gravity g shall be the unit of measurement.

- b) Filter data with a four-pole phaseless Butterworth digital filter, performing the following steps:

- 1) Evaluation of coefficients:

$T = 1/S =$ sampling period in seconds (s);

$CFR = 13$ Hz = filter cut-off frequency.

$$w_d = 2 \pi CFR$$

$$w_a = \frac{\sin\left(w_d \frac{T}{2}\right)}{\cos\left(w_d \frac{T}{2}\right)} = \tan\left(w_d \frac{T}{2}\right)$$

$$a_0 = \frac{w_a^2}{(1 + \sqrt{2} w_a + w_a^2)} \tag{4}$$

$$a_1 = 2 a_0$$

$$a_2 = a_0$$

$$b_1 = \frac{-2(w_a^2 - 1)}{(1 + \sqrt{2} w_a + w_a^2)}$$

$$b_2 = \frac{(-1 + \sqrt{2}w_a - w_a^2)}{(1 + \sqrt{2}w_a + w_a^2)}$$

- 2) For each of the three acceleration components: if:

$X(k)$ is the k^{th} element of any series of measurements; and

$Y(k)$ is the k^{th} element of the filtered series,

$$Y(k) = a_0X(k) + a_1X(k-1) + a_2X(k-2) + b_1Y(k-1) + b_2Y(k-2) \quad (5)$$

where the coefficients a_0 , a_1 , a_2 , b_1 and b_2 shall be computed with (4).

Equation (5) is a two-pole filter. To perform a four-pole phaseless filter data shall pass through the filter twice. Passing data through the filter forward and then backwards through the filter will not phase shift the data.

Startup of the digital filter yields the same response as switching a signal into the input of an analog filter. The digital filter algorithm sees nonzero initial data as a step function, and it responds with a typical under-damped second-order response. If the data set to be filtered contains sufficient pre-event and post-event data, then the initial conditions may be ignored because the filter response to the initial step input will have damped out before the event begins. A minimum of 500 ms of pre-contact data and 500 ms of post-event data shall be recorded for this purpose.

- c) Compute ASI as a function of time:

$$\text{ASI}(k) = \left[(\bar{A}_x/12)^2 + (\bar{A}_y/9)^2 + (\bar{A}_z/10)^2 \right]^{0,5} \quad (6)$$

where

$\bar{A}_x, \bar{A}_y, \bar{A}_z$ are the filtered components of vehicle acceleration.

- d) Find ASI as the maximum of the series of the $\text{ASI}(k)$.
- e) Calculate ASI to at least two decimal places and report to one decimal place by mathematical rounding, i.e. $1,44 = 1,4$, $1,45 = 1,5$.

8.1.3 Procedure to compute THIV

8.1.3.1 General

The theoretical head impact velocity (THIV) concept has been developed for assessing occupant impact severity for vehicles involved in collisions with road vehicle restraint systems. The occupant is considered to be a freely moving object (head) that, as the vehicle changes its speed during contact with the vehicle restraint system, continues moving until it strikes a surface within the interior of the vehicle. The magnitude of the velocity of the theoretical head impact is considered to be a measure of the vehicle to vehicle restraint system impact severity.

8.1.3.2 Theoretical head impact velocity (THIV)

It can be assumed that at the beginning of the contact of the vehicle to the restraint system, both the vehicle and the theoretical head have the same horizontal velocity V_0 , vehicle motion being purely translational.

During impact the vehicle is assumed to move only in a horizontal plane, because high levels of pitch, roll or vertical motion are not of prime importance, unless the vehicle overturns, in which case the test shall be not

acceptable. This extreme event does not need to be considered, as in this case the decision to reject the candidate system will be taken on the basis of visual observation or photographic recording.

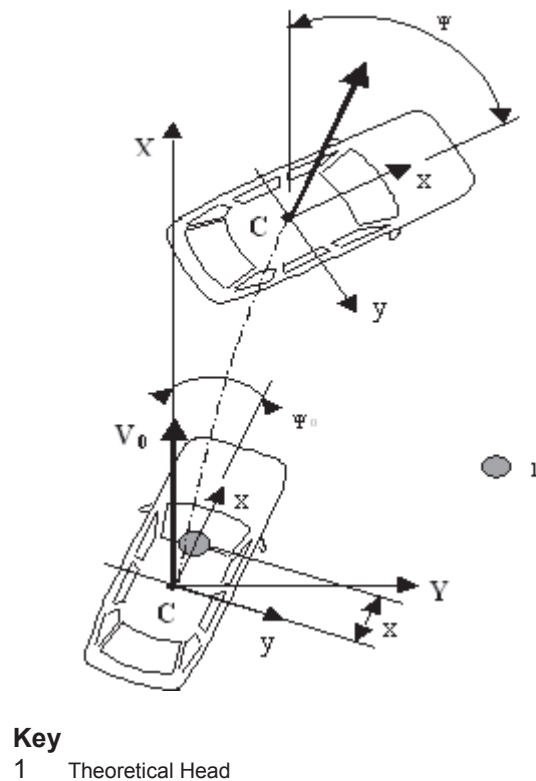

Figure 7 — Vehicle and ground reference frames

Two (right handed) reference frames shall be used, as indicated in Figure 7:

- a) a "vehicle" reference frame C_{xy} , x being longitudinal (positive forwards) and y transverse (positive to the right). This frame moves with the vehicle, so that the origin C is a fixed point within the vehicle close to, but not necessarily coincident with, the centre of mass, where two accelerometers and a yaw rate sensor are installed. This reference frame does not rotate around the x (roll) or y (pitch) axes, but is free to rotate around the z (yaw) axis as the vehicle rotates so that at time t it makes an angle ψ (positive clockwise viewed from above) with the initial direction at $t = 0$.

The vehicle is free to rotate around all three axes, but the analysis assumes that roll (x axis) and pitch (y axis) rotations are small, so that rotation effectively only occurs around the z axis. In this case, the measured accelerations, in metres per square second (m/s^2), recorded by the accelerometers at point C are a_x and a_y in the x and y directions respectively, while the rate of yaw $\dot{\psi}$ (radians per second) may be measured by a sensor at the same location. The measured accelerations a_x and a_y are *not* equal to \ddot{x}_c and \ddot{y}_c . The latter relate to the second differentials of the positions of the vehicle within the reference frame, which are zero, since the vehicle is fixed to the frame;

- b) a "moving ground" reference frame CXY which is coincident with the "vehicle" axis at time $t = 0$, and initially moves with the same velocity as the vehicle. This axis is "inertial", i.e. it moves without acceleration at constant velocity, and does not rotate. It should be noted that although both reference frames are initially moving with the vehicle initial velocity V_0 , the analysis is concerned purely with velocity changes relative to this initial velocity, and so the value of the initial velocity does not enter into the calculations.

Since the freely moving head does not accelerate before it strikes a surface within the vehicle, its co-ordinates in the ground reference frame shall remain constant during the free-flight phase of its motion.

8.1.3.3 Vehicle motion (in the moving but non-rotating ground co-ordinates)

Initial conditions at time $t = 0$:

$$\begin{cases} X_C = 0 & Y_C = 0 & \psi = 0 \\ \dot{X}_C = 0 & \dot{Y}_C = 0 & \dot{\psi} = 0 \end{cases} \quad (7)$$

The yaw angle ψ shall be measured from the recording of a suitable overhead camera, or it shall be computed by integration of the yaw rate $\dot{\psi}$ or other suitable means:

$$\psi(t) = \int_0^t \dot{\psi} dt \quad (8)$$

Then, from the components of vehicle acceleration in ground reference:

$$\begin{cases} \ddot{X}_C = a_x \cos \psi - a_y \sin \psi \\ \ddot{Y}_C = a_x \sin \psi + a_y \cos \psi \end{cases} \quad (9)$$

Vehicle velocity and position shall be computed by integration:

$$\begin{cases} \dot{X}_C = \int_0^t \ddot{X}_C dt \\ \dot{Y}_C = \int_0^t \ddot{Y}_C dt \end{cases} \quad (10)$$

$$\begin{cases} X_C = \int_0^t \dot{X}_C dt \\ Y_C = \int_0^t \dot{Y}_C dt \end{cases} \quad (11)$$

8.1.3.4 Theoretical head motion relative to ground (frame of reference)

The initial conditions of the head relative to the "moving ground" axes relate to its initial position in the vehicle (the frames of reference were defined to be coincident at $t = 0$). x_0 and y_0 are the initial x and y distances of the head from C at $t = 0$ (y_0 is usually taken to be 0). The subscript b shall be used to denote "head", and (0) denotes "at $t = 0$ ".

$$\begin{cases} X_b(0) = x_0 & Y_b(0) = y_0 \\ \dot{X}_b(0) = 0 & \dot{Y}_b(0) = 0 \end{cases} \quad (12)$$

Since the head is in free (non-accelerated) flight, and the "ground" frame of reference is non-accelerated and has a velocity equal to the vehicle velocity at $t = 0$, the head retains its position and velocity in the "ground" frame, until it impacts the vehicle interior. Similarly, because the "vehicle" co-ordinates are fixed relative to the vehicle, the displacement and velocity of the vehicle shall be always zero in "vehicle" co-ordinates. The displacement

(from the initial position) and velocity of the head relative to the vehicle is therefore the negative of the position and velocity of the vehicle relative to ground co-ordinates.

$$\begin{aligned} X_b &= x_0 - X_C; \quad \dot{X}_b = -\dot{X}_C \\ Y_b &= y_0 - Y_C; \quad \dot{Y}_b = -\dot{Y}_C \end{aligned} \quad (13)$$

8.1.3.5 Theoretical head motion relative to vehicle

The displacement co-ordinates of the theoretical head with respect to the vehicle reference frame can therefore be computed from the displacement of the vehicle relative to the "ground" co-ordinates, using the equations:

$$\begin{aligned} x_b(t) &= (x_0 - X_c) \cos \psi + (y_0 - Y_c) \sin \psi & X_c &= \int_0^t \dot{X}_c dt \\ y_b(t) &= -(x_0 - X_c) \sin \psi + (y_0 - Y_c) \cos \psi & Y_c &= \int_0^t \dot{Y}_c dt \end{aligned} \quad (14)$$

The velocity co-ordinates of the theoretical head with respect to the vehicle reference frame are:

$$\begin{aligned} \dot{x}_b(t) &= -\dot{X}_c \cos \psi - \dot{Y}_c \sin \psi + y_b(t) \dot{\psi} \\ \dot{y}_b(t) &= \dot{X}_c \sin \psi - \dot{Y}_c \cos \psi - x_b(t) \dot{\psi} \end{aligned} \quad (15)$$

The terms $x_b(t) \dot{\psi}$ and $y_b(t) \dot{\psi}$ arise from the velocity of a point in the rotating frame of reference at a point with co-ordinates (x_b, y_b) in that frame. The angular rate term $\dot{\psi}$ shall be measured in radians per second (rad/s) and not degrees per second ($^{\circ}/s$). These velocities shall be subtracted from the velocities of the head in the ground (non-rotating) frame, in order to find the velocities of the head relative to the vehicle (rotating) frame.

8.1.3.6 Time of flight

The notional impact surfaces inside the vehicle are assumed to be flat and perpendicular to the vehicle x and y axes (see Figure 8). The distances of such surfaces from the original head position (flail distances) shall be D_x forward and D_y laterally on both sides.

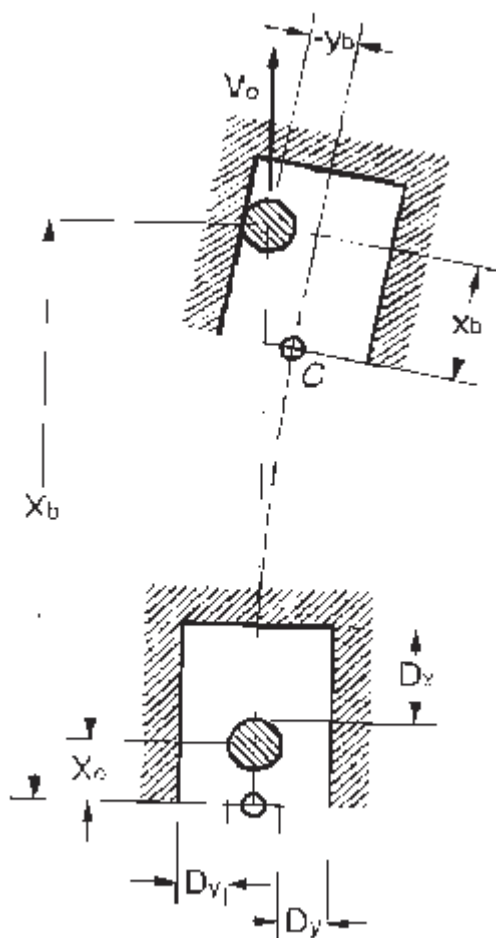

Figure 8 — Impact of the theoretical head on the left side

The time of flight of the theoretical head is the time of impact on one of the three notional surfaces in Figure 6, i.e. the shortest time T when one of the three following equalities shall be satisfied:

$$x_b(T) = D_x + x_o ; \quad \text{or } y_b(T) = D_y ; \quad \text{or } y_b(T) = -D_y \quad (16)$$

The standard values of the flail distances shall be:

- $D_x = 0,6$ m;
- $D_y = 0,3$ m.

8.1.3.7 Value of THIV

Finally, the theoretical head impact velocity shall be the velocity of the head at time T , i.e.:

$$\text{THIV} = [V_x^2(T) + V_y^2(T)]^{0,5} \quad (17)$$

where

$$V_x(T) = \dot{x}_b(T) \text{ and } V_y(T) = \dot{y}_b(T)$$

Calculate THIV to at least one decimal place and report to zero decimal place by mathematical rounding, i.e. 33,4 = 33; 33,5 = 34.

8.1.3.8 Summary of the procedure to compute THIV

- a) Record the vehicle accelerations and yaw rate, and store in digital form at the sample rate S . The data recording shall start at least 500 ms before contact with the vehicle restraint system. Before starting the analysis, it may be necessary to remove any zero biases in the data by a suitable method using the pre-impact data. The data shall then be filtered, as specified in Clause 7.
- b) Interpolate linearly between the measured values of yaw angle to obtain yaw angle data at the same sampling rate as the other recorded data, or alternatively integrate the yaw rate by using the integration routine in suitable analysis software, or alternatively by using a suitable integration algorithm software (Equation (18)).

$$\psi = \int \dot{\psi} dt \quad (18)$$

- c) Compute the vehicle acceleration in "ground" (non-rotating) co-ordinates (Equation (19)).

$$\begin{aligned} \ddot{X}_C &= a_x \cos \psi - a_y \sin \psi \\ \ddot{Y}_C &= a_x \sin \psi + a_y \cos \psi \end{aligned} \quad (19)$$

- d) Integrate the vehicle acceleration in "ground" (non-rotating) co-ordinates (Equations (20) and (21)).

NOTE Before carrying out the integrations, the accelerations must be in units of "ms⁻²" and not "g". If the original recording was in units of "g", the accelerations should be multiplied by 9,81 to give "ms⁻²".

$$\begin{cases} \dot{X}_C = \int_0^t \ddot{X}_C dt \\ \dot{Y}_C = \int_0^t \ddot{Y}_C dt \end{cases} \quad (20)$$

$$\begin{cases} X_C = \int_0^t \dot{X}_C dt \\ Y_C = \int_0^t \dot{Y}_C dt \end{cases} \quad (21)$$

- e) Compute the position and velocity of the theoretical head relative to vehicle based (rotating) co-ordinates (Equations (22) and (23)).

$$x_b(t) = (x_0 - X_c) \cos \psi + (y_0 - Y_c) \sin \psi \quad X_c = \int_0^t \dot{X}_c dt$$

$$y_b(t) = -(x_0 - X_c)\sin\psi + (y_0 - Y_c)\cos\psi \quad Y_c = \int_0^t \dot{Y}_c dt \quad (22)$$

The velocity co-ordinates of the theoretical head with respect to the vehicle reference frame shall be:

$$\begin{aligned} \dot{x}_b(t) &= -\dot{X}_c \cos\psi - \dot{Y}_c \sin\psi + y_b(t)\dot{\psi} \\ \dot{y}_b(t) &= \dot{X}_c \sin\psi - \dot{Y}_c \cos\psi - x_b(t)\dot{\psi} \end{aligned} \quad (23)$$

- f) Find the minimum value of t for which one of the three following equations is satisfied:

$$x_b(t) = D_x + x_0; \quad y_b(t) = D_y; \quad y_b(t) = -D_y \quad (24)$$

- g) Compute:

$$\text{THIV} = [\dot{x}_b^2(t) + \dot{y}_b^2(t)]^{1/2} \quad (25)$$

- h) Calculate THIV to at least one decimal place in kilometres per hour (km/h) and report to 0 decimal place by mathematical rounding, i.e. 33,4 = 33; 33,5 = 34.

8.2 Vehicle cockpit deformation index (VCDI)

8.2.1 Deformation

The purpose of this index is to report a standard description of the deformation of vehicle interior, to help the understanding of the severity of the impact and shall reflect damage to the vehicle caused by the impact with the vehicle restraint system, and not any secondary impacts.

VCDI shall only be determined for cars.

This index designates both the location and the extent of the deformation of the cockpit, and shall consist of two alphabetic characters plus seven numeric characters, in the following form:

XXabcdefg

The accuracy in distance measurements shall be $\pm 0,02$ m.

8.2.2 Location of the deformation

The location of cockpit deformation shall be indicated by the first two alphabetic characters, as indicated in Figure 9.

If no cockpit deformation can be identified then the first two alphabetic characters shall be ND (No Deformation).



a) All seats : XX = AS

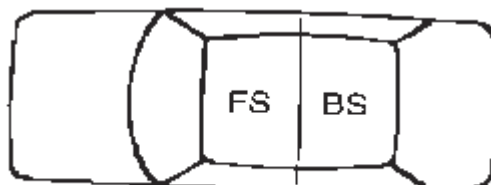

b) Front seats : XX = FS; Back seats : XX = BS

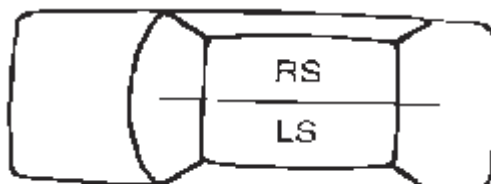

c) Right seats : XX = RS; Left seats : XX = LS

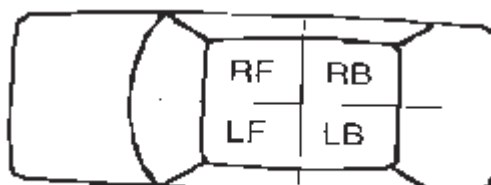

d) Right front : XX = RF; Right back : XX = RB
Left front : XX = LF; Left back : XX = LB

Figure 9 — Location of cockpit deformation

8.2.3 Extent of the deformation

The seven sub-indices a, b, c, d, e, f and g shall indicate the percentage of reduction of seven interior dimensions (see Figure 10).



Key

- a Minimum distance between the dashboard and the top of rear seat
- b Minimum distance between the roof and the floor panel
- c Minimum distance between the rear seat and the motor panel
- d Minimum distance between the lower dashboard and the floor panel
- e Minimum interior width between the right and left lower edges of the windows
- f Minimum distance between the lower edge of right window and the upper edge of left window
- g Minimum distance between the lower edge of left window and the upper edge of right window

Figure 10 — Interior dimensions

Sub-indices a, b, c and d shall be measured on the right, on the left or on the centreline of the vehicle, whichever gives the largest deformation.

Sub-indices e, f and g shall be measured at the front, in the middle or in the back of the cockpit, whichever gives the largest deformation.

The value of each of the seven numeric sub-indices shall be determined by the following scale:

- 0 if the reduction is less than or equal to 3 %;
- 1 if the reduction is more than 3 % and less or equal to 10 %;
- 2 if the reduction is more than 10 % and less or equal to 20%;
- 3 if the reduction is more than 20 %, or cannot be measured due to deformation.

When the reductions exceed 10 %, photographic description of the deformed parts shall be included in the test report.

Any increases shall be reported as "0".

8.2.4 Examples (informative)

a) Example 1

	Measurement before crash test	Measurement after crash test	Reduction less than 3 %	Reduction more than 3 % and less or equal to 10 %	Reduction more than 10 % and less or equal to 20 %	Reduction more than 20 %, or cannot be measured
	cm	cm				
a	163,5	161,5	x			
b	105,5	104,5	x			
c	128,5	123,0		x		
d	32,0	34,0	x			
e	129,0	126,0	x			
f	126,0	130,0	x			
g	126,0	130	x			

VCDI = RS0010000

b) Example 2

	Measurement before crash test	Measurement after crash test	Reduction less than 3 %	Reduction more than 3 % and less or equal to 10 %	Reduction more than 10 % and less or equal to 20 %	Reduction more than 20 %, or cannot be measured
	cm	cm				
a	169,0	164,0	x			
b	104,5	105,0	x			
c	127,5	107,0			x	
d	31,0	20,0				x
e	129,0	128,5	x			
f	125,5	128,0	x			
g	125,5	127,0	x			

VCDI = RS0023000

Annex A (informative)

Calculation of the acceleration severity index (ASI)

The acceleration severity index ASI is a function of time, computed using the following equation:

$$ASI(t) = \left[(\bar{a}_x / \hat{a}_x)^2 + (\bar{a}_y / \hat{a}_y)^2 + \bar{a}_z / \hat{a}_z \right]^{0,5} \quad (\text{A.1})$$

where

\hat{a}_x, \hat{a}_y and \hat{a}_z are limit values for the components of the acceleration along the body axes x, y , and z ;

\bar{a}_x, \bar{a}_y and \bar{a}_z are the components of the acceleration, filtered with a four-pole phaseless Butterworth low-pass digital filter, having a cut-off frequency of 13 Hz.

The index ASI is intended to give a measure of the severity of the motion for a person within a vehicle during an impact with a road restraint system.

The low-pass filtering takes into account the fact that vehicle accelerations can be transmitted to the occupant body through relatively soft contacts, which cannot pass the highest frequencies. The use of the four-pole phaseless Butterworth filter, instead of the previous 50 ms moving average, has been introduced to reduce the scatter of results by reducing the sensitivity to the vibrations of the accelerometer mounting. The value of 13 Hz for the cut-off frequency has been chosen because, on average, it does not change the ASI value computed with the previous procedure.

Equation (A.1) is the simplest possible interaction equation of three variables x, y and z : If any two components of vehicle acceleration are null, ASI reaches its limit value of 1 when the third component reaches its limit acceleration; but when two or three components are non null ASI may be 1 with the single components well below the relevant limits.

The limit accelerations are interpreted as the values below which passenger risk is very small (light injures if any).

For passengers wearing safety belts, the generally used limit accelerations are:

$$\hat{a}_x = 12g, \quad \hat{a}_y = 9g, \quad \hat{a}_z = 10g \quad (\text{A.2})$$

where

$g = 9,81 \text{ ms}^{-2}$ is the reference for the acceleration.

Equation (A.1) ASI is a non-dimensional quantity, which is a scalar function of time, and in general of the selected vehicle point, having only positive values. The more ASI exceeds unity, the more the risk for the occupant in that point exceeds the safety limits; therefore the maximum value attained by ASI in a collision is assumed as a single measure of the severity, or:

$$ASI = \max [ASI(t)] \quad (\text{A.3})$$

Annex B (informative)

Vehicle acceleration - Measurement and calculation methods

B.1 Introduction

During an impact the acceleration of a vehicle can vary from one point to another of the vehicle itself due to angular velocities and angular accelerations. So the measure taken in a single point may not be enough to determine the complete acceleration field within the vehicle.

In general, during a collision there is an internal portion of the vehicle that remains more or less rigid, apart from structural vibrations which are largely filtered out when a suitable low pass filter is applied.

This Annex presents two methods for determining the complete acceleration of the vehicle, considered as a rigid body, at a certain time, from measures taken at the same time. The sensors for these measures should be mounted in locally stiff points of the part of vehicle structure that behaves rigidly.

Knowledge of the complete acceleration field of the vehicle may be needed for computing the acceleration of different points of the vehicle, or to reconstruct vehicle path by integration.

B.2 Acceleration in a rigid body

The acceleration ${}_p a$ of any point P of a rigid body may be expressed in vector notation as:

$${}_p a = {}_c a + \dot{\omega} \times R + \omega \times (\omega \times R) \quad (\text{B.1})$$

where

$${}_p a \equiv \begin{Bmatrix} p^a x \\ p^a y \\ p^a z \end{Bmatrix} \text{ is the acceleration of the generic point P;}$$

$${}_c a \equiv \begin{Bmatrix} c^a x \\ c^a y \\ c^a z \end{Bmatrix} \text{ is the acceleration of a datum point C;}$$

$$\omega \equiv \begin{Bmatrix} \omega_x \\ \omega_y \\ \omega_z \end{Bmatrix} \text{ is the angular velocity of the rigid body;}$$

$R = P - C$ is the radius vector from point C to point P;

Alternatively Equation (B.1) can be also put in the form:

$${}_p a = c^a + \dot{\omega} \wedge R + (\omega.R)\omega - (\omega.\omega)R \quad (\text{B.2})$$

where the point represents scalar product, the dot represents derivation with respect to time, and the symbol \wedge the vector product.

Equation (B.1) can also be written in matrix notation as:

$$\{ {}_p a \} = \{ c^a \} + [A] \{ R \} \quad (\text{B.3})$$

where

$$[A] = \begin{bmatrix} -\omega_y^2 - \omega_z^2 & \omega_x \omega_y - \dot{\omega}_z & \omega_x \omega_z + \dot{\omega}_y \\ \omega_x \omega_y + \dot{\omega}_z & -\omega_x^2 - \omega_z^2 & \omega_y \omega_z - \dot{\omega}_x \\ \omega_x \omega_z - \dot{\omega}_y & \omega_y \omega_z + \dot{\omega}_x & -\omega_x^2 - \omega_y^2 \end{bmatrix} \quad (\text{B.4})$$

and $\{ R \}$ is the column matrix

$$\{ R \} = \begin{bmatrix} R_x \\ R_y \\ R_z \end{bmatrix} \quad (\text{B.5})$$

Then to know the acceleration ${}_p a$ of any point of a rigid body at a certain time t , one needs either to measure the acceleration components a_x , a_y , a_z at exactly that point, or to measure the acceleration components at some other point at a distance R from the point P, together with the angular velocity components of the body ω_x , ω_y , ω_z , and the angular acceleration components $\dot{\omega}_x$, $\dot{\omega}_y$, $\dot{\omega}_z$. At first sight it would appear that nine quantities need to be measured. However, angular acceleration and angular velocity are time series, and are not independent. Since both angular velocity and angular acceleration are vectors (unlike angle), the angular acceleration components can be obtained by simple differentiation of the angular velocity components or angular velocity can be obtained by simple integration of the angular acceleration components. It is therefore necessary to obtain the values of only six quantities, three linear acceleration components and three angular components (velocity or acceleration) in order to be able to calculate the acceleration at any point in a rigid body.

B.3 Methods of measuring rigid body motion

In principle it is necessary to use only six sensors to obtain values for the six quantities. The quantities can be calculated either entirely from acceleration measurements, or from a combination of acceleration and angular measurements.

The simplest and most direct method with current technology is to use three linear accelerometers and three angular velocity sensors. These measurements provide the required quantities directly, with angular acceleration being obtained by differentiation of the angular velocity.

The derivation of angular motion entirely from acceleration measurements is more complicated, and can pose some significant problems. In principle it is possible to obtain all the necessary data from the results of six linear acceleration measurements, with accelerometers suitably located and orientated within the body. The problem is

that the equations for the derivation of angular acceleration include angular velocity terms ($\omega_x \omega_y$, etc.; in Equation (B.3)). These are in turn derived from the angular accelerations ($\dot{\omega}_x$, $\dot{\omega}_y$) derived from previous time steps of the calculation. The process is unstable, and a small error in any of these terms rapidly amplifies, causing major errors unless the overall calculation is limited to a very short time interval.

An alternative method has been developed using nine accelerometers, described by Padgaonkar *et al.* This shows that, if the accelerometers are correctly located and oriented, the terms in angular velocity can be eliminated from the equations, and so the angular accelerations can be expressed directly in terms of accelerometer outputs. The angular velocities can subsequently be obtained by integration, but these angular velocities are not fed back into the derivation of angular acceleration, so the solutions are stable.

If complete freedom of location of accelerometers is required, then it is necessary to be able to calculate all nine elements of the transform matrix A (Equation (B.4)) separately, which (together with calculation of the three linear accelerations) requires outputs from no less than twelve accelerometers. This is becoming very cumbersome, both in terms of provision of sensors and calculation, and is not recommended.

Any attempt to use one of the methods described above should note that:

- a) If the vehicle undergoes significant rotation around the roll or pitch axes, the orientation of accelerometers relative to gravity will change, so the accelerometer outputs will include a component of gravity as well as the acceleration relative to the ground. Gravity will have no effect on calculations of angular motion, but if the results are used for path reconstruction the effects of gravity can be very significant, and should be included in the calculations. The simplest way to do this is to use the principle of equivalence; add a bias of 1 g upward acceleration to the (initially) vertical accelerometer, and then relate the motion of the vehicle to a set of "ground" axes also accelerating upwards at 1 g.
- b) Although double integration of linear acceleration has been used with great success in aircraft inertial navigators, using very high quality accelerometers, the crash hardened accelerometers used in impact tests have limited accuracy, both in terms of initial bias errors (where the accuracy is fundamentally limited by the resolution normally available in the digitiser), and scale errors, normally of the order of 1 %. The accuracy in displacements calculated by double integration of the output from crash accelerometers deteriorates rapidly with increasing time. The method should not normally be used for trajectories lasting much more than a few seconds. It is always desirable to carry out an error analysis for any particular installation.

B.4 Measurement by six linear and three angular transducers

This method requires six linear accelerometers plus three angular rate transducers. Three linear accelerometers and the angular velocity sensors are placed, on a single block, in the datum point C. The three linear accelerometers and the three angular velocity transducers are oriented as the vehicle axes x , y and z .

This gives a direct measure of ${}_c a$ and ω ; so only three unknowns remain to be determined, i.e. the components of $\dot{\omega}$. These can be obtained by adding only three linear accelerometers, as follows.

Put each of the latter three accelerometers in point ${}_i P$, with the alignment specified by the unit vector ${}_i n$ ($i = 1, 2, 3$); upon scalar multiplication by ${}_i n$, Equation (B.2) takes the form:

$${}_i m \cdot \dot{\omega} = P_i \quad (B.6)$$

where

$${}_i R = {}_i P - C \quad \text{is the position vector of } {}_i P;$$

$${}_i m = {}_i R \wedge {}_i n;$$

$$P_i = a_i - {}_c a_i - (\omega \cdot {}_i R) \omega_i + (\omega \cdot \omega) R_i;$$

$a_i = {}_i a \cdot n$ is the measure from the sensor in point ${}_i P$;

${}_c a_i = {}_c a \cdot n$ is the component of ${}_c a$ in the direction of ${}_i n$;

$\omega_i = \omega \cdot n$ is the component of ω in the direction of ${}_i n$;

$R_i = {}_i R \cdot n$ is the component of ${}_i R$ in the direction of ${}_i n$.

Putting together Equation (B.6) for the measures of the latter three transducers the following final form is obtained:

$$[M]\{\dot{\omega}\} = \{p\} \quad (B.7)$$

where

$$[M] = \begin{bmatrix} {}_1 m_x & {}_1 m_y & {}_1 m_z \\ {}_2 m_x & {}_2 m_y & {}_2 m_z \\ {}_3 m_x & {}_3 m_y & {}_3 m_z \end{bmatrix}; \quad \{\dot{\omega}\} = \begin{Bmatrix} \dot{\omega}_x \\ \dot{\omega}_y \end{Bmatrix}; \quad \{p\} = \begin{Bmatrix} p_x \\ p_y \\ p_z \end{Bmatrix} \quad (B.8)$$

From Equation (B.7) the angular acceleration is found in the form:

$$\{\dot{\omega}\} = [M]^{-1} \{p\} \quad (B.9)$$

Such a solution is possible only if matrix $[M]$ is non singular, and this requires that the points ${}_i P$ and the orientations ${}_i n (i = 1, 2, 3)$ of the sensor be carefully selected.

With this all the nine kinematic parameters, i.e. $\{{}_c a\}$, $\{\omega\}$ and $\{\dot{\omega}\}$ are known. They can be used to compute the acceleration of any point P of the vehicle with (B.1), (B.2) or (B.3), or to reconstruct vehicle path with a suitable procedure.

Some good choice of the position and of the orientation of the transducers is reported in the following examples, where the point C is in the xz plane (symmetry plane), close to the vehicle centre of mass, and the remaining three accelerometers are mounted in two points, symmetrical with respect to xz plane. Other good choices are also possible.

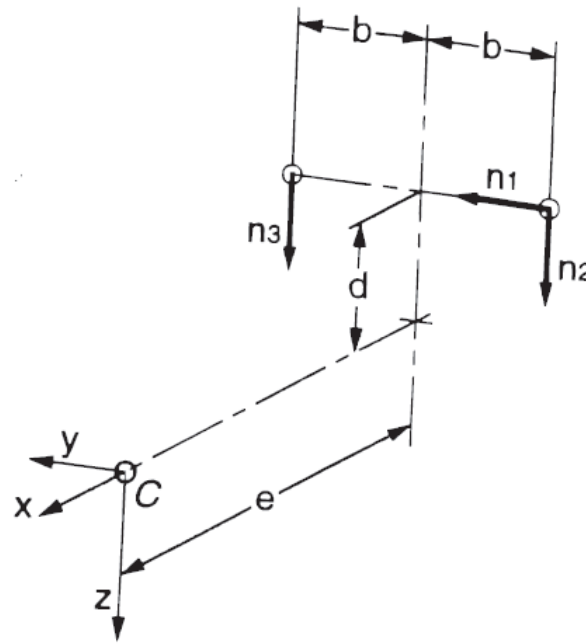

Figure B.1 — Example A

$$[M] = \begin{bmatrix} d & 0 & -e \\ -b & e & 0 \\ b & e & 0 \end{bmatrix}; [M]^{-1} = \begin{bmatrix} 0 & -1/2b & 1/2b \\ 0 & 1/2e & 1/2e \\ -1/e - d/2be & d/2be & \end{bmatrix}$$

$$\{p\} = \begin{cases} a_1 - c a_y - b(\omega_x^2 + \omega_z^2) + e \omega_x \omega_y + d \omega_y \omega_z \\ a_2 - c a_z - d(\omega_x^2 + \omega_y^2) + e \omega_x \omega_z + b \omega_y \omega_z \\ a_3 - c a_z - d(\omega_x^2 + \omega_y^2) + e \omega_x \omega_z - b \omega_y \omega_z \end{cases}$$

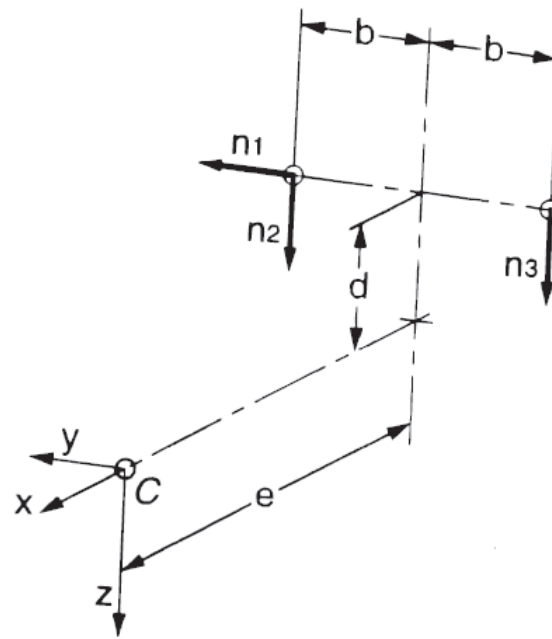

Figure B.2 — Example B

$$[M] = \begin{bmatrix} d & 0 & -e \\ b & e & 0 \\ -b & e & 0 \end{bmatrix}; [M]^{-1} = \begin{bmatrix} 0 & 1/2b & -1/2b \\ 0 & 1/2e & 1/2e \\ -1/e & d/2be & -d/2be \end{bmatrix}$$

$$\{p\} = \begin{cases} a_1 - c a_y + b(\omega_x^2 + \omega_z^2) + e\omega_x\omega_y + d\omega_y\omega_z \\ a_2 - c a_z - d(\omega_x^2 + \omega_y^2) + e\omega_x\omega_z - b\omega_y\omega_z \\ a_3 - c a_z - d(\omega_x^2 + \omega_y^2) + e\omega_x\omega_z + b\omega_y\omega_z \end{cases}$$

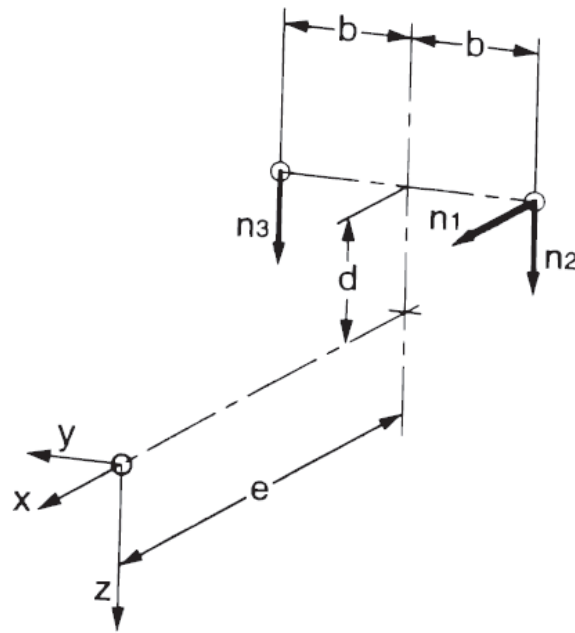

Figure B.3 — Example C

$$[M] = \begin{bmatrix} 0 & -d & b \\ -b & e & 0 \\ b & e & 0 \end{bmatrix}; [M]^{-1} = \begin{bmatrix} 0 & -1/2b & 1/2b \\ 0 & 1/2e & 1/2e \\ 1/b & d/2be & d/2be \end{bmatrix}$$

$$\{p\} = \begin{cases} a_1 - e a_x - e(\omega_y^2 + \omega_z^2) + b\omega_x\omega_y + d\omega_x\omega_z \\ a_2 - e a_z - d(\omega_x^2 + \omega_y^2) + e\omega_x\omega_y + b\omega_y\omega_z \\ a_3 - e a_z - d(\omega_x^2 + \omega_y^2) + e\omega_x\omega_z - b\omega_y\omega_z \end{cases}$$

B.5 Remarks

The first method proposed requires only linear acceleration transducers, but in a redundant number; it is straightforward for the evaluation of the acceleration of any point in the vehicle.

The second method, which requires a minimum number of transducers (six linear accelerations and three angular velocities), is more suitable when a path reconstruction has to be made. Among the three layouts shown in the examples, A is mostly recommended for collisions on the right side, B for collisions on the left side, and C for head on collisions.

In any case in comparing of the two methods the accuracy and the cost of the different transducers should also be considered.

Bibliography

- [1] EN 1317-5:2007+A1:2008, *Road restraint systems — Part 5: Product requirements and evaluation of conformity for vehicle restraint systems*
- [2] prEN 1317-6, *Road restraint systems — Pedestrian restraint systems — Part 6: Pedestrian Parapet*
- [3] ISO 8855, *Road vehicles — Vehicle dynamics and road-holding ability — Vocabulary*
- [4] SAE J211, *Instrumentation for Impact Test*
- [5] Padgaonkar, A.J., Krieger, K.W., King, A.I., "Measurement of Angular Acceleration of a Rigid Body Using Linear Accelerometers", presented at the 1975 Applied Mechanics Summer Conference of The American Society of Mechanical Engineers, and reprinted in the *Journal of Applied Mechanics*, September 1975

British Standards Institution (BSI)

BSI is the national body responsible for preparing British Standards and other standards-related publications, information and services.

BSI is incorporated by Royal Charter. British Standards and other standardization products are published by BSI Standards Limited.

About us

We bring together business, industry, government, consumers, innovators and others to shape their combined experience and expertise into standards-based solutions.

The knowledge embodied in our standards has been carefully assembled in a dependable format and refined through our open consultation process. Organizations of all sizes and across all sectors choose standards to help them achieve their goals.

Information on standards

We can provide you with the knowledge that your organization needs to succeed. Find out more about British Standards by visiting our website at bsigroup.com/standards or contacting our Customer Services team or Knowledge Centre.

Buying standards

You can buy and download PDF versions of BSI publications, including British and adopted European and international standards, through our website at bsigroup.com/shop, where hard copies can also be purchased.

If you need international and foreign standards from other Standards Development Organizations, hard copies can be ordered from our Customer Services team.

Subscriptions

Our range of subscription services are designed to make using standards easier for you. For further information on our subscription products go to bsigroup.com/subscriptions.

With **British Standards Online (BSOL)** you'll have instant access to over 55,000 British and adopted European and international standards from your desktop. It's available 24/7 and is refreshed daily so you'll always be up to date.

You can keep in touch with standards developments and receive substantial discounts on the purchase price of standards, both in single copy and subscription format, by becoming a **BSI Subscribing Member**.

PLUS is an updating service exclusive to BSI Subscribing Members. You will automatically receive the latest hard copy of your standards when they're revised or replaced.

To find out more about becoming a BSI Subscribing Member and the benefits of membership, please visit bsigroup.com/shop.

With a **Multi-User Network Licence (MUNL)** you are able to host standards publications on your intranet. Licences can cover as few or as many users as you wish. With updates supplied as soon as they're available, you can be sure your documentation is current. For further information, email bsmusales@bsigroup.com.

BSI Group Headquarters

389 Chiswick High Road London W4 4AL UK

Revisions

Our British Standards and other publications are updated by amendment or revision.

We continually improve the quality of our products and services to benefit your business. If you find an inaccuracy or ambiguity within a British Standard or other BSI publication please inform the Knowledge Centre.

Copyright

All the data, software and documentation set out in all British Standards and other BSI publications are the property of and copyrighted by BSI, or some person or entity that owns copyright in the information used (such as the international standardization bodies) and has formally licensed such information to BSI for commercial publication and use. Except as permitted under the Copyright, Designs and Patents Act 1988 no extract may be reproduced, stored in a retrieval system or transmitted in any form or by any means – electronic, photocopying, recording or otherwise – without prior written permission from BSI. Details and advice can be obtained from the Copyright & Licensing Department.

Useful Contacts:

Customer Services

Tel: +44 845 086 9001

Email (orders): orders@bsigroup.com

Email (enquiries): cservices@bsigroup.com

Subscriptions

Tel: +44 845 086 9001

Email: subscriptions@bsigroup.com

Knowledge Centre

Tel: +44 20 8996 7004

Email: knowledgecentre@bsigroup.com

Copyright & Licensing

Tel: +44 20 8996 7070

Email: copyright@bsigroup.com



...making excellence a habit.™