

BS EN 1027:2016



BSI Standards Publication

Windows and doors — Water tightness — Test method

National foreword

This British Standard is the UK implementation of EN 1027:2016. It supersedes BS EN 1027:2000 which is withdrawn.

The UK participation in its preparation was entrusted to Technical Committee B/538/1, Windows and doors.

A list of organizations represented on this committee can be obtained on request to its secretary.

This publication does not purport to include all the necessary provisions of a contract. Users are responsible for its correct application.

© The British Standards Institution 2016.
Published by BSI Standards Limited 2016

ISBN 978 0 580 82210 0

ICS 91.060.50

Compliance with a British Standard cannot confer immunity from legal obligations.

This British Standard was published under the authority of the Standards Policy and Strategy Committee on 30 June 2016.

Amendments/corrigenda issued since publication

Date	Text affected
------	---------------

EUROPEAN STANDARD

EN 1027

NORME EUROPÉENNE

EUROPÄISCHE NORM

March 2016

ICS 91.060.50

Supersedes EN 1027:2000

English Version

Windows and doors - Water tightness - Test methodFenêtres et portes - Etanchéité à l'eau - Méthode
d'essaiFenster und Türen - Schlagregendichtheit -
Prüfverfahren

This European Standard was approved by CEN on 9 January 2016.

CEN members are bound to comply with the CEN/CENELEC Internal Regulations which stipulate the conditions for giving this European Standard the status of a national standard without any alteration. Up-to-date lists and bibliographical references concerning such national standards may be obtained on application to the CEN-CENELEC Management Centre or to any CEN member.

This European Standard exists in three official versions (English, French, German). A version in any other language made by translation under the responsibility of a CEN member into its own language and notified to the CEN-CENELEC Management Centre has the same status as the official versions.

CEN members are the national standards bodies of Austria, Belgium, Bulgaria, Croatia, Cyprus, Czech Republic, Denmark, Estonia, Finland, Former Yugoslav Republic of Macedonia, France, Germany, Greece, Hungary, Iceland, Ireland, Italy, Latvia, Lithuania, Luxembourg, Malta, Netherlands, Norway, Poland, Portugal, Romania, Slovakia, Slovenia, Spain, Sweden, Switzerland, Turkey and United Kingdom.

EUROPEAN COMMITTEE FOR STANDARDIZATION
COMITÉ EUROPÉEN DE NORMALISATION
EUROPÄISCHES KOMITEE FÜR NORMUNG**CEN-CENELEC Management Centre: Avenue Marnix 17, B-1000 Brussels**

Contents		Page
European foreword		3
1	Scope	4
2	Normative references	4
3	Terms and definitions	4
4	Principle of test	5
5	Test apparatus	5
6	Preparation of test specimen	6
6.1	Set-up of the test specimen	6
6.2	Set-up spraying system (see Figures A.1 to A.6)	6
6.2.1	General	6
6.2.2	Positioning of the line connecting the nozzle tips (the nozzle line)	6
6.2.3	Positioning relative to test specimen width	7
6.2.4	Direction of nozzle spray	7
6.2.5	Number of nozzle rows	7
6.3	Water characteristics	7
7	Test procedure	7
7.1	Preliminaries	7
7.2	Spraying phase	8
7.3	Test result	8
8	Test report	8
Annex A (informative) Watertightness		10
Bibliography		16

European foreword

This document (EN 1027:2016) has been prepared by Technical Committee CEN/TC 33 “Doors, windows, shutters, building hardware and curtain walling”, the secretariat of which is held by AFNOR.

This European Standard shall be given the status of a national standard, either by publication of an identical text or by endorsement, at the latest by September 2016, and conflicting national standards shall be withdrawn at the latest by September 2016.

Attention is drawn to the possibility that some of the elements of this document may be the subject of patent rights. CEN [and/or CENELEC] shall not be held responsible for identifying any or all such patent rights.

This document supersedes EN 1027:2000.

The revision of this European Standard clarifies only the test method and does not affect existing test evidence of EN 1027:2000.

This European Standard is one of a series of standards for windows and doorsets.

In comparison with EN 1027:2000, the following significant changes were made:

- a) Clause 2: Deletion of "Normative references";
- b) Clause 3: Supplement of definition “closing condition”;
- c) Sub-clause 3.2: Simplification of definition “test pressure”;
- d) Sub-clause 3.3: Revision of definition “watertightness”;
- e) Sub-clause 3.4: Revision of definition “water penetration”;
- f) Sub-clause 5.4: Revision of definition "accuracy";
- g) Sub-clause 6.2: Editorial changes;
- h) Sub-clause 6.2.4.1 and 6.2.4.2: More precise description;
- i) Sub-clause 7.1: Addition of "closing condition";
- j) Clause 8: Supplement of necessary description of test specimen;
- k) New Annex A: Revision of former Figures 1 and 2, separation of Figures into Figure A.1 up to Figure A.4;
- l) New Annex A: Supplement of Figure A.5.

According to the CEN/CENELEC Internal Regulations, the national standards organizations of the following countries are bound to implement this European Standard: Austria, Belgium, Bulgaria, Croatia, Cyprus, Czech Republic, Denmark, Estonia, Finland, Former Yugoslav Republic of Macedonia, France, Germany, Greece, Hungary, Iceland, Ireland, Italy, Latvia, Lithuania, Luxembourg, Malta, Netherlands, Norway, Poland, Portugal, Romania, Slovakia, Slovenia, Spain, Sweden, Switzerland, Turkey and the United Kingdom.

1 Scope

This European Standard defines the test method to be used to determine the watertightness of completely assembled windows and doorsets of any materials. This test method is designed to take account of conditions in use, when the window or doorset is installed in accordance with the manufacturer's specification and the requirements of relevant European Standards and codes of practice.

This European Standard does not apply to the joints between the window or door frame and the building construction.

2 Normative references

Not applicable.

3 Terms and definitions

For the purposes of this document, the following terms and definitions apply.

3.1 closing condition

3.1.1

closed

movable parts rest in or at the fixed parts in a way in which they may be fastened (latched and/or locked)

3.1.2

fastened

where the movable part is restrained at one or more points and shall be described by at least one of the two as listed below

3.1.2.1

latched

movable part is returned to its closed position and restrained by either

a) a self - engaging fastener or

b) a roller catch or

c) a latch

3.1.2.2

locked

movable part is further restrained in the closed position by additional operations (of e.g. handle, key, automatic devices or electronic devices) to engage integrated locking devices (e.g. nutbolts or deadbolts) which will affect the product's characteristics

3.1.3

secured

any action(s) which prevent unauthorised release of the fastening device(s) to allow exit or entry (e.g. child safety, burglary)

3.2

test pressure

difference between the static air pressures inside and outside of the test chamber

Note 1 to entry: The test pressure is positive if the static air pressure inside the chamber of the test apparatus is higher than that outside the test chamber.

Note 2 to entry: The test pressure is negative if the static air pressure inside the chamber of the test apparatus is lower than that outside the test chamber.

3.3

watertightness

ability of the test specimen to resist water penetration under the test conditions up to a pressure (P_{\max} = limit of the watertightness)

3.4

water penetration

continuous or repeated wetting of

- 1) parts of the inside face of the test specimen or
- 2) any parts of the test specimen intended to remain dry, not being part of the water drainage system to the outside, or
- 3) any parts of the test specimen where water does not drain to the outside in a controlled way

Note 1 to entry: Continuous wetting could be described as an uninterrupted sequence of water, e.g. thin line of water, repeated wetting could be described as frequent intervals of water, e.g. more than one drop of water.

3.5

limit of watertightness

maximum test pressure P_{\max} up to which the test specimen remains watertight under the test conditions for the specified time

4 Principle of test

Constant spraying of a specified quantity of water onto the external surface of the test specimen while increments of positive test pressure are applied at regular intervals during which details are recorded of test pressure and location of water penetration.

5 Test apparatus

5.1 A chamber with an open side to which the test specimen can be fitted. It shall be constructed so as to be able to withstand the test pressures without deflecting to an extent likely to influence the test results.

5.2 Means for applying controlled test pressure to the test specimen.

5.3 Means of producing rapid changes in test pressure, controlled within defined limits.

5.4 Instrument suitable for measuring the quantity of water supplied within an accuracy of $\pm 10\%$ of the measured value.

If several rows of nozzles with different flows are included, the total flow of water has to be checked. It shall be in accordance with 5.6 c). Furthermore the spraying pattern of the lower row of nozzles has to be checked additionally.

It is recommended to use at least two such instruments.

NOTE 1 Accuracy = \pm (the sum of the amount of the error plus the amount of the expanded measurement uncertainty). For values of both error and expanded measurement uncertainty see last calibration certificate of the instrument.

NOTE 2 For vocabulary of metrology see ISO/IEC Guide 99:2007.

5.5 Means of measuring the test pressure applied across the test specimen, within an accuracy of $\pm 5\%$.

5.6 A spraying system capable of applying a continuous regularly dispersed film of water, all over the surface likely to be wetted in real exposure conditions, by means of full circular cone nozzles with the following features:

- a) angle of spray: $(120_{-10}^0)^\circ$;
- b) pressure working range: 2 bar to 3 bar according to manufacturer's specifications;
- c) nozzle rate: top row $(2 \pm 0,2)$ l/min per nozzle, additional rows $(1 \pm 0,1)$ l/min per nozzle and $(2 \pm 0,2)$ l/min per nozzle (see 6.2.5).

6 Preparation of test specimen

6.1 Set-up of the test specimen

The test specimen shall be fixed as intended for use without any twists or bends which may influence the test results. The test specimen shall be fully operable. The surround shall be prepared and installed so that any water penetration, including that through the frame joints, shall be readily detectable.

The test specimen shall be cleaned and surfaces dry.

Ventilation devices, if any, shall be taped over.

6.2 Set-up spraying system (see Figures A.1 to A.6)

6.2.1 General

The method of spraying (Method A or Method B) shall be chosen by the manufacturer based on the location of the test specimen in the intended works (shielded or not)A test shall be carried out using only one set up. A template is recommended to set up the spraying system.

6.2.2 Positioning of the line connecting the nozzle tips (the nozzle line)

The nozzle line shall be located not more than 150 mm above the topmost horizontal joint line of any moving frame or the glazing line of any fixed glazing, in order to provide complete wetting of the adjacent horizontal frame member(s).The nozzle line shall be located at a distance of (250^{+10}_0) mm from the external face of the test specimen as defined by the outermost external joint plane of moving parts or the glazing plane of fixed parts.

6.2.3 Positioning relative to test specimen width

Nozzles shall be spaced at (400 ± 10) mm along the axis of the spray bar and the nozzles shall be arranged in order that the lateral distance „c“ between the outer edge of the surround and the outermost nozzles shall be greater than 50 mm but not exceeding 250 mm (see Figure A.6).

6.2.4 Direction of nozzle spray

The nozzle axis shall lie on a line $(24^{+2}_0)^\circ$ below the horizontal line for test according to Method 1A, and $(84 \pm 2)^\circ$ for test according to Method 1B (see Figures A.1 and A.2).

6.2.5 Number of nozzle rows

6.2.5.1 For test specimens with a height up to 2,5 m, including e.g. extension profiles and/or shutter boxes (see Figure A.5) a single row of nozzles shall be used, with each nozzle spraying, on average, 2 l/min for spraying Method 1A and spraying Method 1B.

NOTE The prescribed spraying rates above are appropriate for 2,5 m high test specimen. For smaller test specimen the nozzles spray water beyond the sill, hence the actual flow on the sprayed area is approximately

- 2 l/(min·m²) when test is carried out according to Method 1A,
- 1 l/(min·m²) when test is carried out according to Method 1B.

6.2.5.2 For test specimens exceeding 2,5 m height (see Figures A.3 and A.4), including e.g. extension profiles and/or shutter boxes (see Figure A.5), an upper row of nozzles shall be fixed as described in 6.2.5.1. Additional rows of nozzles shall be fixed at vertical intervals at 1,5 m (within a tolerance of ± 150 mm) below the top nozzle line. Where any horizontal projection occurs, these additional rows shall be installed at a level such that no water is sprayed upwards under the projection. The flow of each nozzle shall be on average

- 1 l/min for spraying Method 2A,
- 2 l/min for spraying Method 2B.

6.2.5.3 For test specimens containing one or more horizontal water bars which project more than 50 mm (see Figure A.8) an additional row of nozzles, as described in 6.2.5.2, shall be arranged for each water bar as shown in Figure A.2.

6.3 Water characteristics

Water temperature shall be between 4 °C and 30 °C and the water shall be clean enough to ensure that all nozzles spray correctly.

7 Test procedure

7.1 Preliminaries

The ambient temperature and humidity close to the test specimen shall be within the range of 10 °C to 30 °C and 25 % to 75 % RH and the test specimen shall be conditioned thus for at least 4 h immediately before testing.

Temperature shall be measured to within ± 3 °C and humidity to within ± 5 %. Atmospheric pressure shall be measured to within ± 1 kPa.

All the opening parts of the test specimen shall be opened and closed at least once before the test. After that the test specimen shall be brought into the closing condition in accordance with the manufacturer's instructions.

Three positive test pressure pulses shall be applied, the duration of increase in test pressure shall not be less than 1 s. Each pulse shall be maintained for at least 3 s. These pulses shall produce a test pressure 10 % greater than the maximum test pressure required for the test, without, however being less than 500 Pa.

7.2 Spraying phase

Spraying is applied first with the test pressure of 0 Pa for 15 min then with the test pressure increasing every 5 min (see Figure A.7). Overall duration is dependent on the watertightness of the test specimen. The duration of each pressure steps shall be within a tolerance of $+1/0$ min. The test pressure shall be applied in steps of 50 Pa up to 300 Pa and from 300 Pa in steps of 150 Pa. Immediately prior to testing the flow of each row of nozzles shall be adjusted according to 5.6.

7.3 Test result

Report the location and pressure at which any water penetrated the test specimen and the time for which the maximum pressure was maintained before water penetrated.

NOTE This data will preferably be marked on a drawing of the face view of the test specimen.

8 Test report

The test report shall state the watertightness measurement devices used for the test and, if needed, record on a drawing or a photograph of the test specimen the location of any significant water penetration observed. The report shall contain as a minimum for a single set of results the following information:

- a) reference to this European Standard;
- b) the name of the test institution;
- c) date of the test;
- d) all necessary references to identify the test specimen and the method of sampling;
- e) all relevant details concerning the dimensions of the test specimen, its materials, design, construction and manufacture and its surface finish and fittings, including building hardware, locking points, their position and specific design (e.g. with / without rear-engaging, mushroom cams), relevant gaskets and/or seals with dimensions of the gaps where they are seated.
- f) exposed face: opening inwards or outwards;
- g) description of at least one of the following closing conditions:
 - closed,
 - latched,
 - locked;

- h) dimensioned drawings of all relevant details of the test specimen including cross section; the fixing of the frame strikers (number of screws used for the fixing, and details into which material they were screw-fixed) shall be clearly depicted in these drawings (see e.g. Figures A.1 to A.5);
- i) presence of ventilation, type and condition (i.e. closed, taped over etc.);
- j) the spraying method;
- k) test procedures, including storage and conditioning prior to test, and mounting the test specimen ready for test;
- l) test climates used;
- m) test results.

Annex A
(informative)

Watertightness

Dimensions in mm

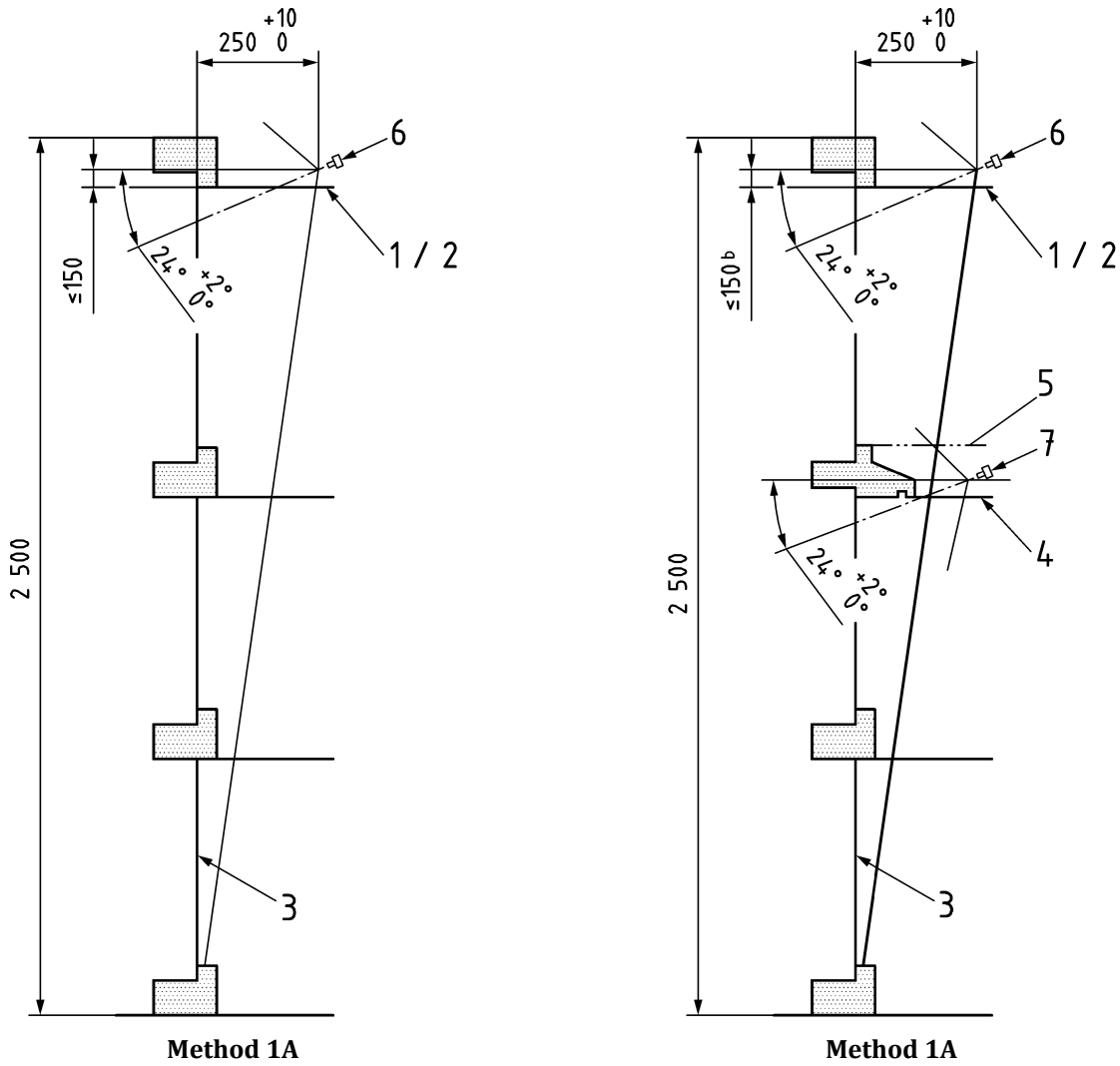

Key

- 1 nozzle lip shall be above the topmost horizontal joint line and spray the head member thoroughly
- 2 limit of spray
- 3 outermost external joint plane or glazing plane
- 4 nozzle lip shall be above this level
- 5 nozzle lip shall be under this level
- 6 $(2 \pm 0,2)$ l/min per nozzle
- 7 $(1 \pm 0,1)$ l/min per nozzle

Figure A.1 — Test specimen not more than 2 500 mm - Method 1A

Dimensions in mm

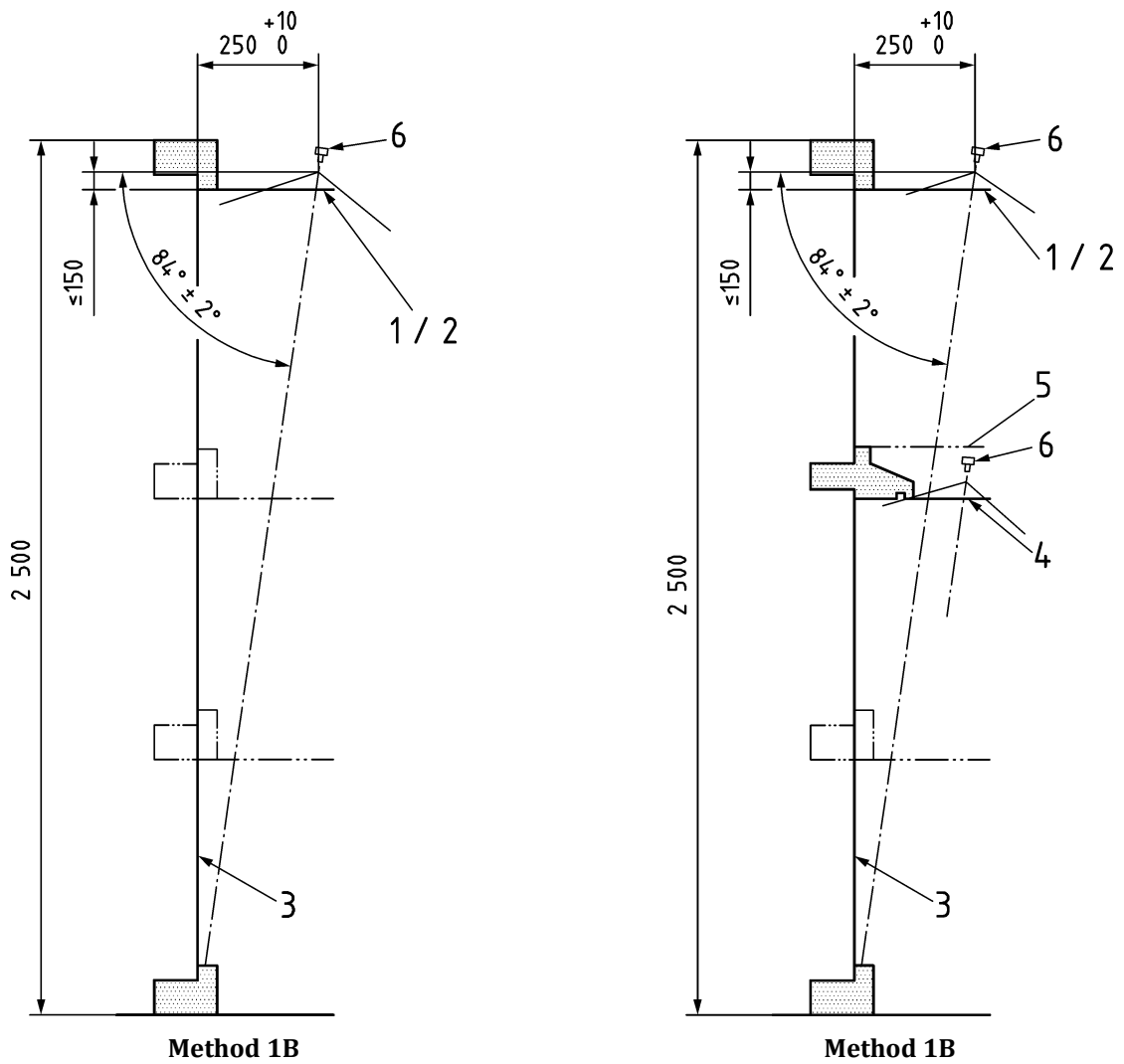

Key

- 1 nozzle lip shall be above the topmost horizontal joint line and spray the head member thoroughly
- 2 limit of spray
- 3 outermost external joint plane or glazing plane
- 4 nozzle lip shall be above this level
- 5 nozzle lip shall be under this level
- 6 $(2 \pm 0,2)$ l/min per nozzle

Figure A.2 — Test specimen not more than 2 500 mm - Method 1B

Dimensions in mm

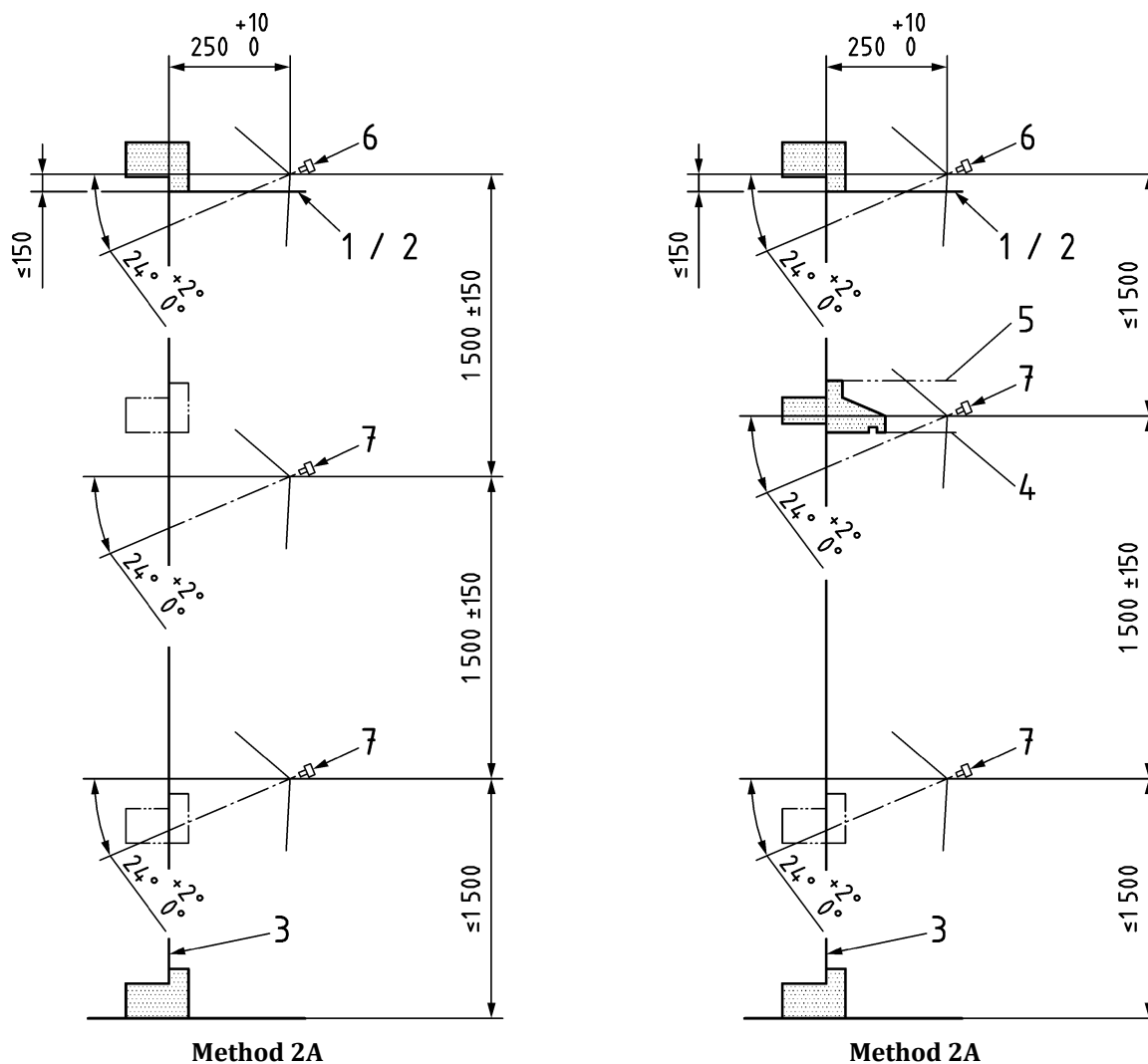

Key

- 1 nozzle lip shall be above the topmost horizontal joint line and spray the head member thoroughly
- 2 limit of spray
- 3 outermost external joint plane or glazing plane
- 4 nozzle lip shall be above this level
- 5 nozzle lip shall be under this level
- 6 $(2 \pm 0,2)$ l/min per nozzle
- 7 $(1 \pm 0,1)$ l/min per nozzle

Figure A.3 — Test specimen more than 2 500 mm or with horizontal water bar projecting more than 50 mm – Method 2A (see Figure A.8)

Dimensions in mm

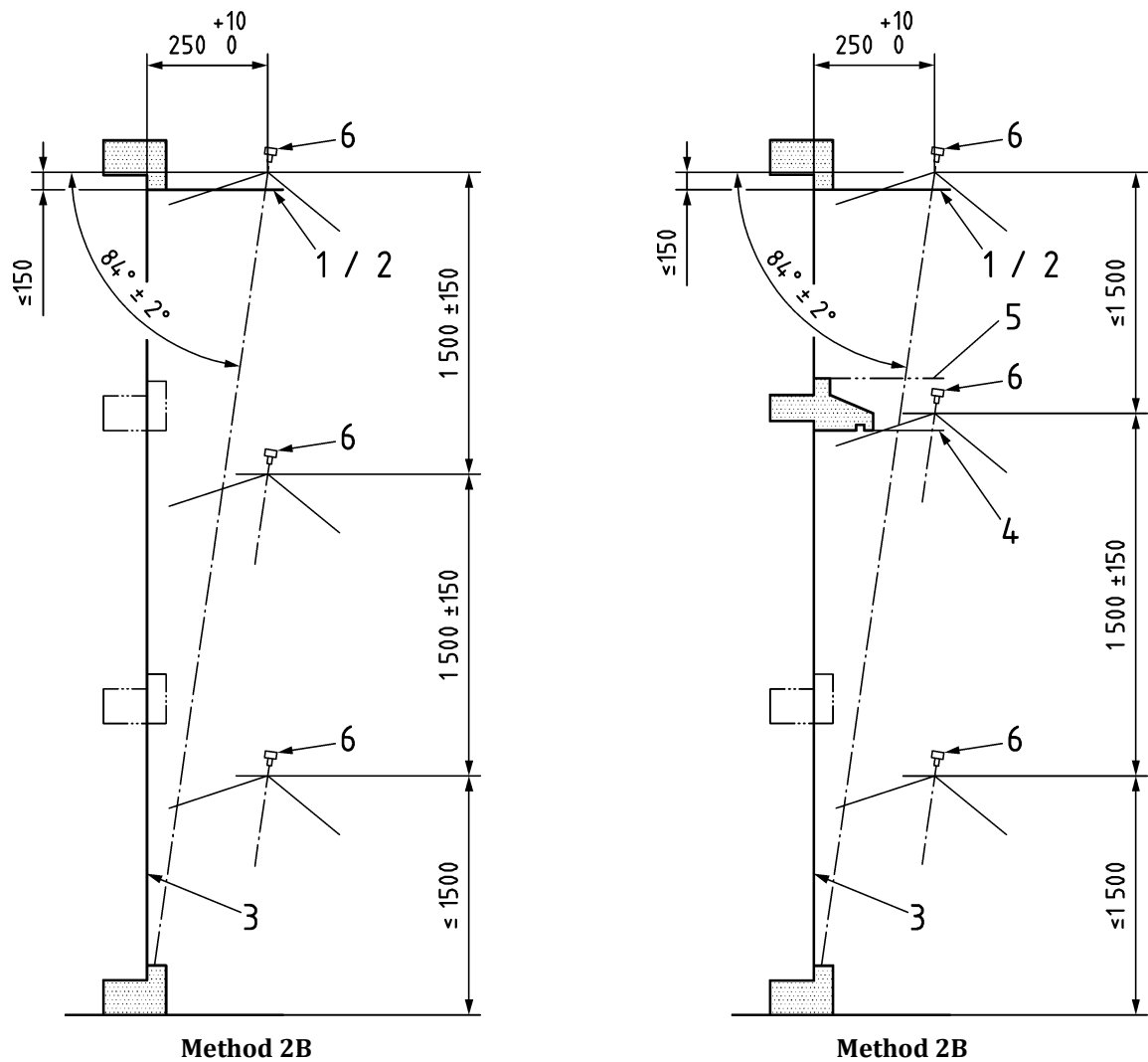

Key

- 1 nozzle lip shall be above the topmost horizontal joint line and spray the head member thoroughly
- 2 limit of spray
- 3 outermost external joint plane or glazing plane
- 4 nozzle lip shall be above this level
- 5 nozzle lip shall be under this level
- 6 $(2 \pm 0,2)$ l/min per nozzle

Figure A.4 — Test specimen more than 2 500 mm or with horizontal water bar projecting more than 50 mm – Method 2B (see Figure A.8)

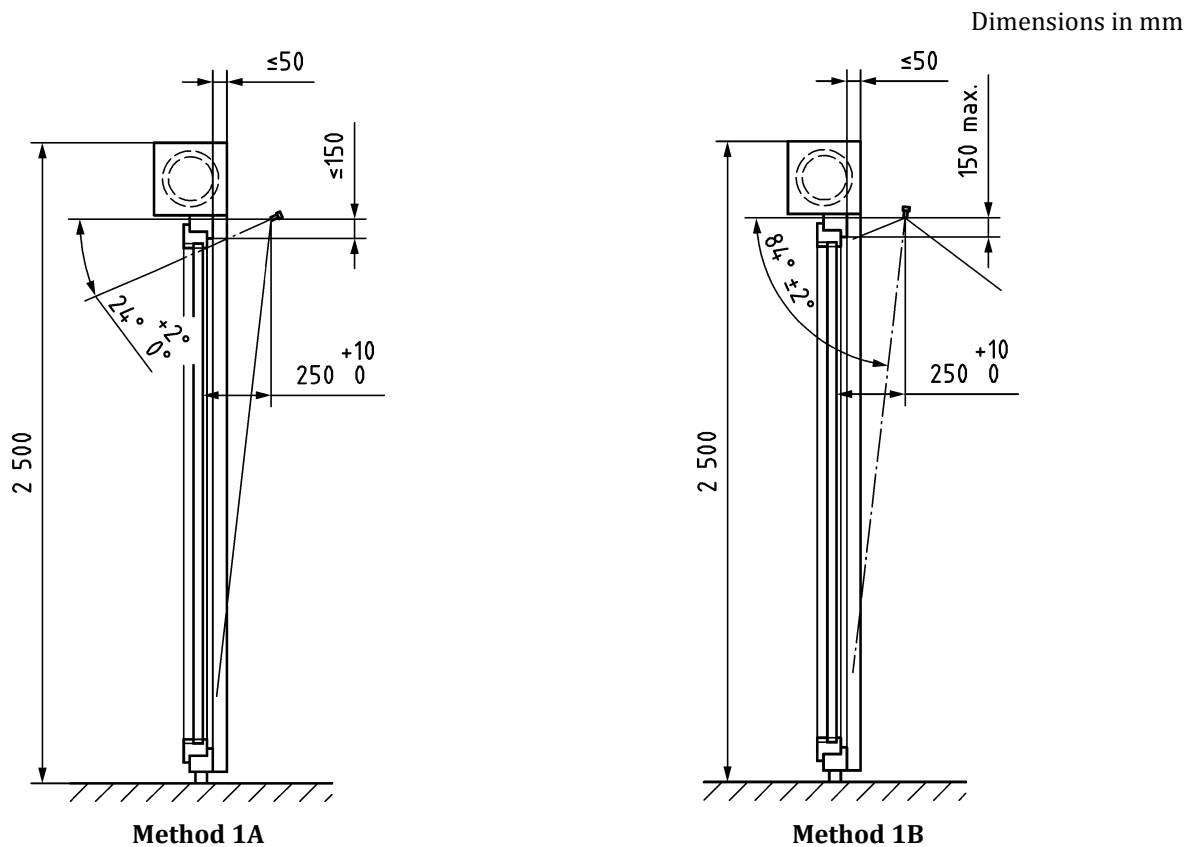
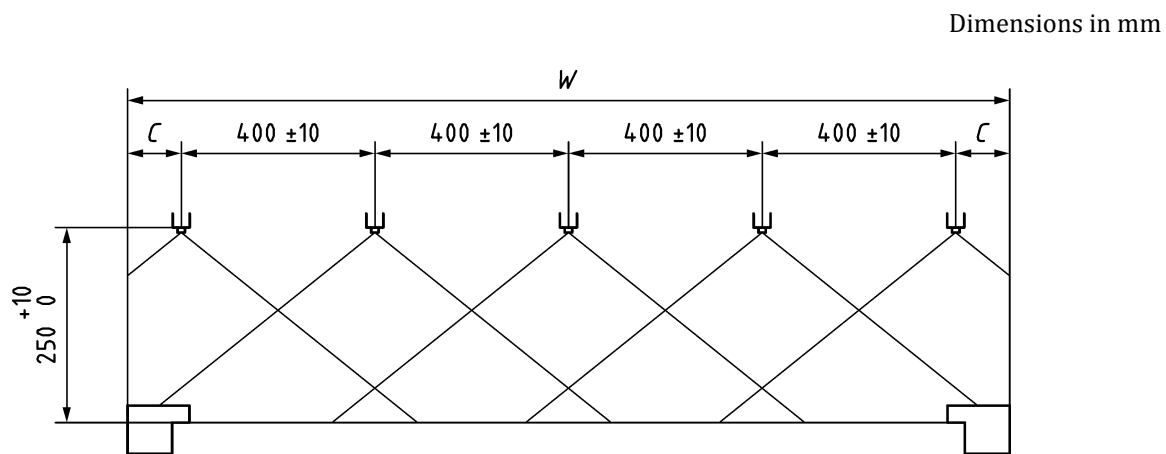

Figure A.5 — Test specimen including extension profiles and shutter box



Key

- C* between 50 mm and 250 mm
- W* width

Figure A.6 — Set-up of nozzles (plan view)

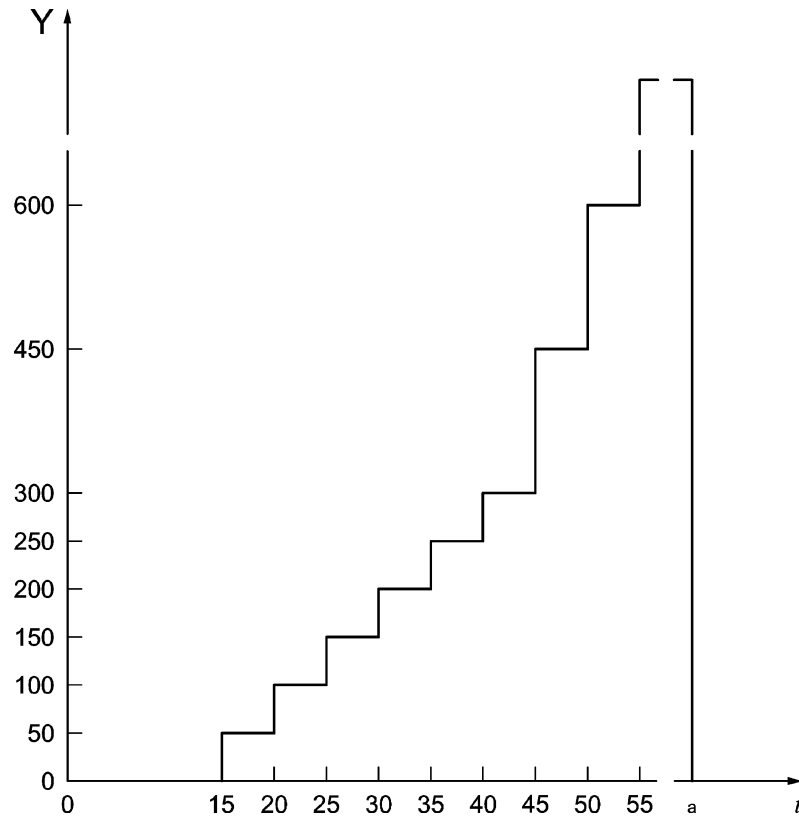

Key

- Y test pressure, in Pa
- t time, in min
- a additional test pressure steps

Figure A.7 — Principle of test pressure steps

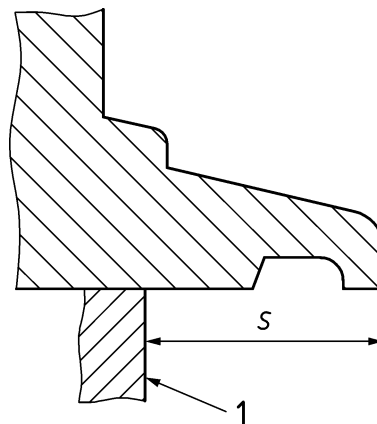

Key

- 1 plane of an infill, leaf or casement
- If $S > 50$ mm an additional spraying line of nozzles is required below the water bar
- If $S \leq 50$ mm no additional spraying line of nozzles is needed

Figure A.8 — Definition of horizontal projection

Bibliography

EN 12208, *Windows and doors — Watertightness — Classification*

ISO/IEC Guide 99:2007, *International vocabulary of metrology — Basic and general concepts and associated terms (VIM)*

British Standards Institution (BSI)

BSI is the national body responsible for preparing British Standards and other standards-related publications, information and services.

BSI is incorporated by Royal Charter. British Standards and other standardization products are published by BSI Standards Limited.

About us

We bring together business, industry, government, consumers, innovators and others to shape their combined experience and expertise into standards-based solutions.

The knowledge embodied in our standards has been carefully assembled in a dependable format and refined through our open consultation process. Organizations of all sizes and across all sectors choose standards to help them achieve their goals.

Information on standards

We can provide you with the knowledge that your organization needs to succeed. Find out more about British Standards by visiting our website at bsigroup.com/standards or contacting our Customer Services team or Knowledge Centre.

Buying standards

You can buy and download PDF versions of BSI publications, including British and adopted European and international standards, through our website at bsigroup.com/shop, where hard copies can also be purchased.

If you need international and foreign standards from other Standards Development Organizations, hard copies can be ordered from our Customer Services team.

Copyright in BSI publications

All the content in BSI publications, including British Standards, is the property of and copyrighted by BSI or some person or entity that owns copyright in the information used (such as the international standardization bodies) and has formally licensed such information to BSI for commercial publication and use.

Save for the provisions below, you may not transfer, share or disseminate any portion of the standard to any other person. You may not adapt, distribute, commercially exploit, or publicly display the standard or any portion thereof in any manner whatsoever without BSI's prior written consent.

Storing and using standards

Standards purchased in soft copy format:

- A British Standard purchased in soft copy format is licensed to a sole named user for personal or internal company use only.
- The standard may be stored on more than 1 device provided that it is accessible by the sole named user only and that only 1 copy is accessed at any one time.
- A single paper copy may be printed for personal or internal company use only.

Standards purchased in hard copy format:

- A British Standard purchased in hard copy format is for personal or internal company use only.
- It may not be further reproduced – in any format – to create an additional copy. This includes scanning of the document.

If you need more than 1 copy of the document, or if you wish to share the document on an internal network, you can save money by choosing a subscription product (see 'Subscriptions').

Reproducing extracts

For permission to reproduce content from BSI publications contact the BSI Copyright & Licensing team.

Subscriptions

Our range of subscription services are designed to make using standards easier for you. For further information on our subscription products go to bsigroup.com/subscriptions.

With **British Standards Online (BSOL)** you'll have instant access to over 55,000 British and adopted European and international standards from your desktop. It's available 24/7 and is refreshed daily so you'll always be up to date.

You can keep in touch with standards developments and receive substantial discounts on the purchase price of standards, both in single copy and subscription format, by becoming a **BSI Subscribing Member**.

PLUS is an updating service exclusive to BSI Subscribing Members. You will automatically receive the latest hard copy of your standards when they're revised or replaced.

To find out more about becoming a BSI Subscribing Member and the benefits of membership, please visit bsigroup.com/shop.

With a **Multi-User Network Licence (MUNL)** you are able to host standards publications on your intranet. Licences can cover as few or as many users as you wish. With updates supplied as soon as they're available, you can be sure your documentation is current. For further information, email subscriptions@bsigroup.com.

Revisions

Our British Standards and other publications are updated by amendment or revision.

We continually improve the quality of our products and services to benefit your business. If you find an inaccuracy or ambiguity within a British Standard or other BSI publication please inform the Knowledge Centre.

Useful Contacts

Customer Services

Tel: +44 345 086 9001

Email (orders): orders@bsigroup.com

Email (enquiries): cservices@bsigroup.com

Subscriptions

Tel: +44 345 086 9001

Email: subscriptions@bsigroup.com

Knowledge Centre

Tel: +44 20 8996 7004

Email: knowledgecentre@bsigroup.com

Copyright & Licensing

Tel: +44 20 8996 7070

Email: copyright@bsigroup.com

BSI Group Headquarters

389 Chiswick High Road London W4 4AL UK