

BS EN 856:2015



BSI Standards Publication

Rubber hoses and hose assemblies — Rubber-covered spiral wire reinforced hydraulic type — Specification

bsi.

...making excellence a habit.™

National foreword

This British Standard is the UK implementation of EN 856:2015. It supersedes BS EN 856:1997 which is withdrawn.

BSI, as a member of CEN, is obliged to publish EN 856 as a British Standard. However, attention is drawn to the fact that during the development of this European Standard, the UK committee voted against its approval as a European Standard.

This is due to concerns about the abrasion test method detailed in Annex A (normative). It is the opinion of the UK committee that the abrasion test method is not reliable and gives inconsistent results.

The UK participation in its preparation was entrusted to Technical Committee PRI/66, Rubber and plastics tubing, hoses and hose assemblies.

A list of organizations represented on this committee can be obtained on request to its secretary.

This publication does not purport to include all the necessary provisions of a contract. Users are responsible for its correct application.

© The British Standards Institution 2015.

Published by BSI Standards Limited 2015

ISBN 978 0 580 76536 0

ICS 23.040.70

Compliance with a British Standard cannot confer immunity from legal obligations.

This British Standard was published under the authority of the Standards Policy and Strategy Committee on 31 May 2015.

Amendments/corrigenda issued since publication

Date	Text affected
------	---------------

EUROPEAN STANDARD

EN 856

NORME EUROPÉENNE

EUROPÄISCHE NORM

April 2015

ICS 23.100.40

Supersedes EN 856:1996

English Version

Rubber hoses and hose assemblies - Rubber-covered spiral wire reinforced hydraulic type - Specification

Tuyaux et flexibles en caoutchouc - Type hydraulique avec armature hélicoïdale de fils métalliques - Spécification

Gummischläuche und -schlauchleitungen - Hydraulikschläuche mit Drahtspiraleinlage - Spezifikation

This European Standard was approved by CEN on 31 January 2015.

CEN members are bound to comply with the CEN/CENELEC Internal Regulations which stipulate the conditions for giving this European Standard the status of a national standard without any alteration. Up-to-date lists and bibliographical references concerning such national standards may be obtained on application to the CEN-CENELEC Management Centre or to any CEN member.

This European Standard exists in three official versions (English, French, German). A version in any other language made by translation under the responsibility of a CEN member into its own language and notified to the CEN-CENELEC Management Centre has the same status as the official versions.

CEN members are the national standards bodies of Austria, Belgium, Bulgaria, Croatia, Cyprus, Czech Republic, Denmark, Estonia, Finland, Former Yugoslav Republic of Macedonia, France, Germany, Greece, Hungary, Iceland, Ireland, Italy, Latvia, Lithuania, Luxembourg, Malta, Netherlands, Norway, Poland, Portugal, Romania, Slovakia, Slovenia, Spain, Sweden, Switzerland, Turkey and United Kingdom.



EUROPEAN COMMITTEE FOR STANDARDIZATION
COMITÉ EUROPÉEN DE NORMALISATION
EUROPÄISCHES KOMITEE FÜR NORMUNG

CEN-CENELEC Management Centre: Avenue Marnix 17, B-1000 Brussels

Contents

Page

Foreword.....	3
1 Scope	4
2 Normative references	4
3 Types of hose	5
4 Materials and construction	5
4.1 Hoses	5
4.2 Hose assemblies	5
5 Dimensions	5
5.1 Diameters and concentricity	5
5.2 Length	7
5.2.1 Hoses	7
5.2.2 Hose assemblies	7
6 Requirements	8
6.1 Hydrostatic requirements	8
6.2 Minimum bend radius	8
6.3 Impulse test requirements	9
6.4 Leakage of hose assemblies	9
6.5 Cold flexibility	9
6.6 Adhesion between components	9
6.7 Abrasion resistance	9
6.8 Fluid resistance	9
6.8.1 Test pieces	9
6.8.2 Oil resistance	10
6.8.3 Water based fluid resistance	10
6.8.4 Water resistance	10
6.9 Ozone resistance	10
7 Designation	10
8 Marking	10
8.1 Hoses	10
8.2 Hose assemblies	11
Annex A (normative) Procedure for the measurement of abrasion	12
A.1 Apparatus	12
A.2 Method	13
A.3 Test pieces	13
A.4 Condition of test pieces	13
A.5 Procedure	14
A.6 Expression of results	14
A.7 Test report	14
Annex B (normative) Type and routine testing of production hoses	16
Annex C (informative) Production acceptance testing	17

Foreword

This document (EN 856:2015) has been prepared by Technical Committee CEN/TC 218 “Rubber and plastics hoses and hose assemblies”, the secretariat of which is held by BSI.

This European Standard shall be given the status of a national standard, either by publication of an identical text or by endorsement, at the latest by October 2015 and conflicting national standards shall be withdrawn at the latest by October 2015.

Attention is drawn to the possibility that some of the elements of this document may be the subject of patent rights. CEN [and/or CENELEC] shall not be held responsible for identifying any or all such patent rights.

This document supersedes EN 856:1996.

In comparison with EN 856:1996, the following significant changes have been made:

- updated normative references;
- tolerances for inside diameter in Table 1;
- added Annex A;
- added Annex B;
- added Annex C.

According to the CEN-CENELEC Internal Regulations, the national standards organizations of the following countries are bound to implement this European Standard: Austria, Belgium, Bulgaria, Croatia, Cyprus, Czech Republic, Denmark, Estonia, Finland, Former Yugoslav Republic of Macedonia, France, Germany, Greece, Hungary, Iceland, Ireland, Italy, Latvia, Lithuania, Luxembourg, Malta, Netherlands, Norway, Poland, Portugal, Romania, Slovakia, Slovenia, Spain, Sweden, Switzerland, Turkey and the United Kingdom.

1 Scope

This European Standard specifies requirements for four types of rubber-covered spiral wire reinforced hydraulic hoses and hose assemblies of nominal bore from 6 to 51: Types 4SP, 4SH, R12 and R13. They are all suitable for use with:

- hydraulic fluids in accordance with ISO 6743-4 with the exception of HFD R, HFD S and HFD T at temperatures ranging from $-40\text{ }^{\circ}\text{C}$ to $+100\text{ }^{\circ}\text{C}$ for types 4SP and 4SH and $-40\text{ }^{\circ}\text{C}$ to $+120\text{ }^{\circ}\text{C}$ for types R12 and R13;
- water based fluids at temperatures ranging from $-40\text{ }^{\circ}\text{C}$ to $70\text{ }^{\circ}\text{C}$;
- water fluids at temperatures ranging from $0\text{ }^{\circ}\text{C}$ to $70\text{ }^{\circ}\text{C}$.

This European Standard does not include requirements for end fittings. It is limited to the performance of hoses and hose assemblies.

NOTE 1 The hoses are not suitable for use with castor oil based nor ester based fluids.

NOTE 2 Hoses and hose assemblies are not be operated outside the limits of this standard.

NOTE 3 Requirements for hydraulic hoses for underground mining are standardised in a separate standard.

2 Normative references

The following documents, in whole or in part, are normatively referenced in this document and are indispensable for its application. For dated references, only the edition cited applies. For undated references, the latest edition of the referenced document (including any amendments) applies.

EN ISO 1302, *Geometrical Product Specifications (GPS) - Indication of surface texture in technical product documentation (ISO 1302)*

EN ISO 1402:2009, *Rubber and plastics hoses and hose assemblies - Hydrostatic testing (ISO 1402:2009)*

EN ISO 4671, *Rubber and plastics hoses and hose assemblies - Methods of measurement of the dimensions of hoses and the lengths of hose assemblies (ISO 4671)*

EN ISO 6743-4, *Lubricants, industrial oils and related products (class L) - Classification - Part 4: Family H (Hydraulic systems) (ISO 6743-4)*

EN ISO 6803, *Rubber or plastics hoses and hose assemblies - Hydraulic-pressure impulse test without flexing (ISO 6803)*

EN ISO 7326, *Rubber and plastics hoses - Assessment of ozone resistance under static conditions (ISO 7326)*

EN ISO 8033:2006, *Rubber and plastics hoses - Determination of adhesion between components (ISO 8033:2006)*

EN ISO 10619-2, *Rubber and plastics hoses and tubing - Measurement of flexibility and stiffness - Part 2: Bending tests at sub-ambient temperatures (ISO 10619-2)*

ISO 1817:2005, *Rubber, vulcanized - Determination of the effect of liquids*

ISO 23529, *Rubber - General procedures for preparing and conditioning test pieces for physical test methods*

3 Types of hose

Four types of hose are specified:

- 1) Type 4SP – a 4-steel wire spiral medium pressure hose;
- 2) Type 4SH – a 4-steel wire spiral extra high pressure hose;
- 3) Type R12 – a 4 steel wire spiral heavy duty high temperature hose – medium pressure rating;
- 4) Type R13 – a multiple steel wire spiral heavy duty high temperature hose – high pressure rating.

4 Materials and construction

4.1 Hoses

Hoses shall consist of an oil and water resistant synthetic rubber lining, spiral plies of steel wire wrapped in alternating directions, and an oil and weather resistant synthetic rubber cover. Each spiral wire ply shall be separated by an insulating layer of synthetic rubber.

4.2 Hose assemblies

Hose assemblies shall only be manufactured with those hose fittings whose functionality has been verified in accordance with subclauses 6.1, 6.3, 6.4 and 6.5 of this European Standard.

5 Dimensions

5.1 Diameters and concentricity

When measured in accordance with EN ISO 4671, the diameters of the hoses shall conform to the values given in Table 1.

Table 1 — Diameters of hoses

Dimensions in millimetres, except nominal bore

Nominal bore	Inside diameter							
	Type 4SP		Type 4SH		Type R12		Type R13	
	min.	max.	min.	max.	min.	max.	min.	max.
6	6,2	7,0	-	-	-	-	-	-
10	9,4	10,1	-	-	9,3	10,1	-	-
12	12,6	13,5	-	-	12,3	13,5	-	-
16	15,8	16,7	-	-	15,5	16,7	-	-
19	18,8	19,8	19,1	19,8	18,6	19,8	18,6	19,8
25	25,4	26,4	25,5	26,4	25,0	26,4	25,0	26,4
31	31,8	33,0	32,0	33,0	31,4	33,0	31,4	33,0
38	38,0	39,3	38,2	39,3	37,7	39,3	37,7	39,3
51	50,6	52,0	50,6	52,0	50,4	52,0	50,4	52,0

When measured in accordance with EN ISO 4671, the diameter over reinforcement and outside diameter of the hoses shall conform to the values given in Table 2.

Table 2 — Diameter over reinforcement and outside diameter

Dimensions in millimetres, except nominal bore

Nominal bore	Type 4SP				Type 4SH				Type R12				Type R13			
	Diameter over reinforcement		Outside diameter of hose		Diameter over reinforcement		Outside diameter of hose		Diameter over reinforcement		Outside diameter of hose		Diameter over reinforcement		Outside diameter of hose	
	min.	max.	min.	max.	min.	max.	min.	max.	min.	max.	min.	max.	min.	max.	min.	max.
6	14,1	15,3	17,1	18,7	-	-	-	-	-	-	-	-	-	-	-	-
10	16,9	18,1	20,6	22,2	-	-	16,6	17,8	19,5	21,0	-	-	-	-	-	-
12	19,4	21,0	23,8	25,4	-	-	19,9	21,5	23,0	24,6	-	-	-	-	-	-
16	23,0	24,6	27,4	29,0	-	-	23,8	25,4	26,6	28,8	-	-	-	-	-	-
19	27,4	29,0	31,4	33,0	27,6	29,2	26,9	28,4	29,9	31,5	28,2	29,8	28,2	29,8	31,0	33,2
25	34,5	36,1	38,5	40,9	34,4	36,0	34,1	35,7	36,8	39,2	34,9	36,4	34,9	36,4	37,6	39,8
31	45,0	47,0	49,2	52,4	40,9	42,9	42,7	45,1	45,4	48,6	45,6	48,0	45,6	48,0	48,3	51,3
38	51,4	53,4	55,6	58,8	47,8	49,8	49,2	51,6	51,9	55,0	53,1	55,5	53,1	55,5	55,8	58,8
51	64,3	66,3	68,2	71,4	62,2	64,2	62,5	64,8	65,1	68,3	66,9	69,3	66,9	69,3	69,5	72,7

When measured in accordance with EN ISO 4671, the concentricity of the hoses shall comply with the values given in Table 3.

Table 3 — Concentricity of hoses

Dimensions in millimetres, except nominal bore

Nominal bore	Maximum variation in wall thickness	
	Between inside diameter and outside diameter	Between internal diameter and reinforcement diameter
6	0,8	0,5
Over 6 and including 19	1,0	0,7
Over 19	1,3	0,9

5.2 Length

5.2.1 Hoses

Hoses shall be supplied in lengths as specified by the purchaser, subject to a tolerance on the specified lengths of $\pm 2\%$.

When no specific hose lengths have been ordered, the percentages of different lengths in any given delivery shall be as follows:

- over 20 m : not less than 80 % of total length;
- over 10 m up to and including 20 m : not more than 20 % of total length;
- 1 m up to and including 10 m : not more than 3 % of total length.

All hose lengths shall be at least 1 m.

5.2.2 Hose assemblies

The tolerances on the length of hose assemblies shall conform to the values given in Table 4.

Table 4 — Tolerances of length of hose assemblies

Hose assembly length mm	Up to and including 25	Nominal bore Over 25 and including 50	Over 50
	Tolerance	Tolerance	Tolerance
Up to and including 630	+ 7 mm - 3 mm	+ 12 mm - 4 mm	+25 mm -6 mm
Over 630 and including 1 250	+ 12 mm - 4 mm	+ 20 mm - 6 mm	
Over 1 250 and including 2 500	+ 20 mm - 6 mm	+ 25 mm - 6 mm	
Over 2 500 and including 8 000	+ 1,5 % - 0,5 %		
Over 8 000	+ 3 % - 1 %		

6 Requirements

6.1 Hydrostatic requirements

6.1.1 When tested in accordance with EN ISO 1402, the maximum working pressure, the proof pressure and burst pressure of the hoses and hose assemblies shall conform to the values given in Table 5.

Table 5 — Maximum working pressure, proof pressure and burst pressure

Nominal bore	Maximum working pressure bar ^a				Proof pressure bar				Burst pressure bar			
	Type				Type				Type			
	4SP	4SH	R12	R13	4SP	4SH	R12	R13	4SP	4SH	R12	R13
6	450	-	-	-	900	-	-	-	1 800	-	-	-
10	445	-	280	-	890	-	560	-	-	-	1 120	-
12	415	-	280	-	830	-	560	-	1 780	-	-	-
16	350	-	280	-	700	-	560	-	1 660	-	1 120	-
19	350	420	280	345	700	840	560	690	1 400	1 680	1 120	1 380
25	280	380	280	345	560	760	560	690	1 400	1 520	1 120	1 380
31	210	325	210	345	420	650	420	690	1 120	1 300	1 120	1 380
38	185	290	175	345	370	580	350	690	840	1 160	840	1 380
51	165	250	175	345	330	500	350	690	740	1 000	700	1 380
									660		700	

^a 1 bar = 0,1 MPa.

6.1.2 When tested in accordance with EN ISO 1402, the change in length of hose at maximum working pressure shall not exceed +2 % to -4 % for types 4SP and 4SH and ±2 % for types R12 and R13.

6.2 Minimum bend radius

When bent to the minimum bend radius given in Table 6 measured on the inside of the bend, the hose shall conform, in the bent state, to the impulse and cold flexibility of 6.3 and 6.5.

Table 6 — Minimum bend radius

Dimensions in millimetres, except nominal bore

Nominal bore	Minimum bend radius			
	Type 4SP	Type 4SH	Type R12	Type R13
6	150	-	-	-
10	180	-	130	-
12	230	-	180	-
16	250	-	200	-
19	300	280	240	240
25	340	340	300	300
31	460	460	420	420
38	560	560	500	500
51	660	700	630	630

6.3 Impulse test requirements

6.3.1 The impulse test shall be in accordance with EN ISO 6803. The test temperature shall be 100 °C for types 4SP and 4SH and 120 °C for types R12 and R13.

6.3.2 For types 4SP and 4SH hose, when tested at impulse pressure equal to 133 % of the maximum working pressure, the hose shall withstand a minimum of 400 000 impulse cycles.

For type R12 hose, tested at impulse pressure equal to 133 % of the maximum working pressure, the hose shall withstand a minimum of 500 000 impulse cycles.

For type R13 hose, tested at impulse pressure equal to 120 % of the maximum working pressure, the hose shall withstand a minimum of 500 000 impulse cycles.

6.3.3 There shall be no leakage or other malfunction before reaching the specified number of cycles.

6.3.4 This test shall be considered a destructive test and the test piece shall be disposed of in accordance with local environmental guidelines.

6.4 Leakage of hose assemblies

When tested in accordance with EN ISO 1402:2009, 8.4 there shall be no leakage or evidence of failure. This test shall be considered a destructive test and the test piece shall be disposed of in accordance with local environmental guidelines.

6.5 Cold flexibility

When tested in accordance with method B of EN ISO 10619-2 at a temperature of -40 °C there shall be no cracking of the lining or cover. The test piece shall not leak or crack when subjected to a proof pressure test in accordance with EN ISO 1402 after regaining ambient temperature.

6.6 Adhesion between components

When tested in accordance with EN ISO 8033:2006, the adhesion for hose types 4SP and 4SH between lining and reinforcement, and between cover and reinforcement shall not be less than 2,5 kN/m.

When tested in accordance with EN ISO 8033:2006, the adhesion for hose types R12 and R13 between lining and reinforcement, and between cover and reinforcement shall not be less than 1,4 kN/m.

Test pieces shall be type 5 for lining and reinforcement and type 2 or type 6 for cover and reinforcement as described in Table 1 of EN ISO 8033:2006.

6.7 Abrasion resistance

All hose types shall be tested in accordance with Annex A.

For all hose types when tested with a vertical force of $(50 \pm 0,5)$ N the loss of mass after 2 000 cycles shall not be greater than 1 g for the average value of three or more test pieces.

6.8 Fluid resistance

6.8.1 Test pieces

The fluid resistance tests shall be carried out on moulded sheets of lining and cover compound, 2 mm minimum thickness, of an equivalent cure state to that of the hose.

6.8.2 Oil resistance

When tested in accordance with ISO 1817, the lining of types 4SP and 4SH immersed in Oil No. 3 for 168 h at a temperature of 100 °C shall show no shrinkage and no volume swelling greater than 60 %.

When tested in accordance with ISO 1817, the cover of types 4SP and 4SH immersed in Oil No. 3 for 168 h at a temperature of 70 °C shall show no shrinkage and no volume swelling greater than 100 %.

When tested in accordance with ISO 1817, the lining and cover of hose types R12 and R13, immersed in Oil No. 3 for 70 h at a temperature of 120 °C, shall show no shrinkage and no volume swelling greater than 100 % for the lining 125 % for the cover.

6.8.3 Water based fluid resistance

When tested in accordance with ISO 1817, the lining and cover immersed in a test liquid made up of equal volumes of 1,2-ethanediol and distilled water for 168 h at a temperature of 70 °C shall show no shrinkage. The volume swelling shall be not greater than 25 % for the lining and 100 % for the cover.

6.8.4 Water resistance

When tested in accordance with ISO 1817, the lining and cover immersed in distilled water for 168 h at a temperature of 70 °C shall show no shrinkage. The volume swelling shall be not greater than 25 % for the lining and 100 % for the cover.

6.9 Ozone resistance

The test shall be in accordance with EN ISO 7326, Method 1 or 2, depending on the nominal bore of the hose. There shall be no cracking and no deterioration of the cover visible under x2 magnification.

7 Designation

Hoses shall be designated as the following example.

Designation of a Type 4SP hydraulic hose with spiral wire reinforcement and a nominal bore of 10:

Hose EN 856 — 4SP 10

8 Marking

8.1 Hoses

Hoses shall be marked at a maximum spacing of 500 mm with at least the following information:

- a) manufacturer's name or identification, e.g. XXX;
- b) the number of this European Standard 'EN 856';
- c) type, e.g. 4SP;
- d) nominal bore e.g. 16;
- e) quarter and last two digits of year of manufacture e. g. 1Q15.

EXAMPLE XXX/EN 856/4SP/16/1Q15.

NOTE Other information, as agreed between the purchaser and the manufacturer, may be included, if requested.

8.2 Hose assemblies

Hose assemblies shall be marked preferably at the assemblies with at least the following information:

- a) Hose assembler's name or identification, e.g. XXX;
- b) maximum working pressure of the assemblies, in bar e.g. 350;
- c) the last two digits of year and month of assembly, e.g. 1501.

EXAMPLE XXX/350bar/1501.

NOTE Other information, as agreed between the purchaser and the hose assembler, may be included, if requested.

Annex A (normative)

Procedure for the measurement of abrasion

A.1 Apparatus

This method uses an apparatus consisting of a wheel and crank arrangement, capable of moving the abrading tool 100 mm back and forth along the test piece with sinusoidal motion at a rate of 1,25 Hz (one cycle equals 200 mm of travel). A typical arrangement is shown in Figure A.1. The traversing arrangement shall be designed to ensure that

- a) the mid-point of the traversed length is coincident with the mid-point of the assembled hose and mandrel;
- b) the axes of the abrading tool and hose are mutually perpendicular at the mid-point;
- c) the plane of travel is parallel to the longitudinal axis of the test piece.

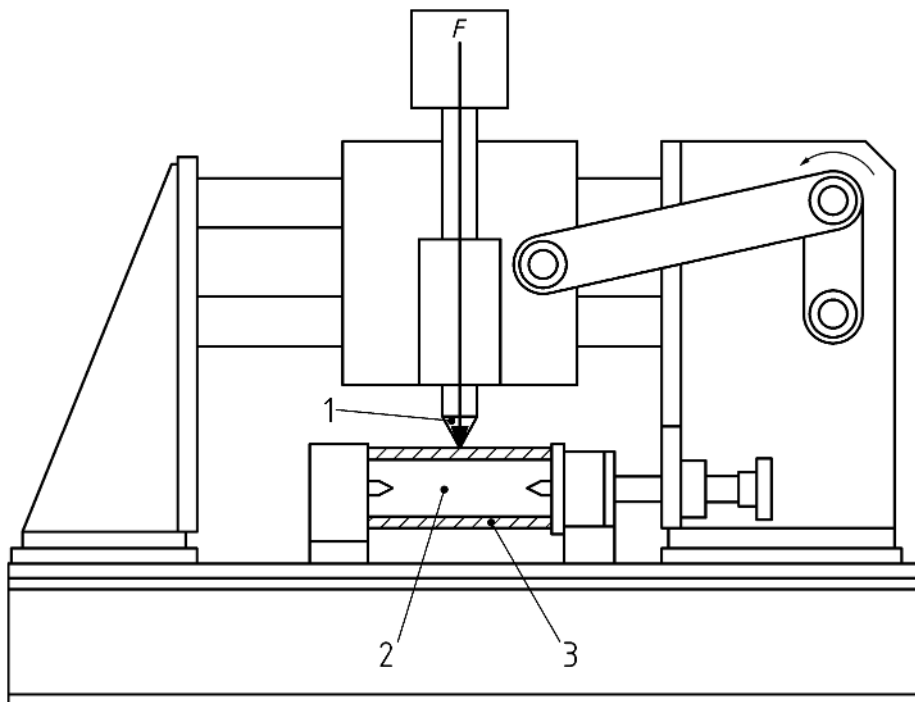

Key

- 1 abrading tool
- 2 mandrel
- 3 hose test piece

Figure A.1 — Typical test apparatus

This method requires a recording device, to record the number of cycles completed, and capable of being pre-set to terminate the test after completion of the specified number of cycles.

This method requires means of applying a vertical force F , as specified in this product standard, to the abrading tool at the point of contact with the test piece.

This method requires a mandrel, 150 mm long, on to which the test piece will fit tightly. It is essential that the mandrel is a tight fit in the test piece to prevent distortion of the test piece under the action of the reciprocating abrading tool. For accurate determinations, it is recommended that the mandrel is made of lightweight materials and is of hollow section, so that it is capable of supporting the abrading load but its mass is kept to an absolute minimum. If a solid mandrel is used, this shall be removed prior to weighing the test piece, taking care to avoid loss of material from the hose lining.

A.2 Method

This method uses an abrading tool manufactured from tool steel, heat-treated to give a minimum hardness of HV 890.

The principal dimensions shall be as shown in Figure A.2. It is essential that the specified profile and surface finish are maintained, and that any extraneous material on the surface of the abrading tool is cleaned off before testing is started.

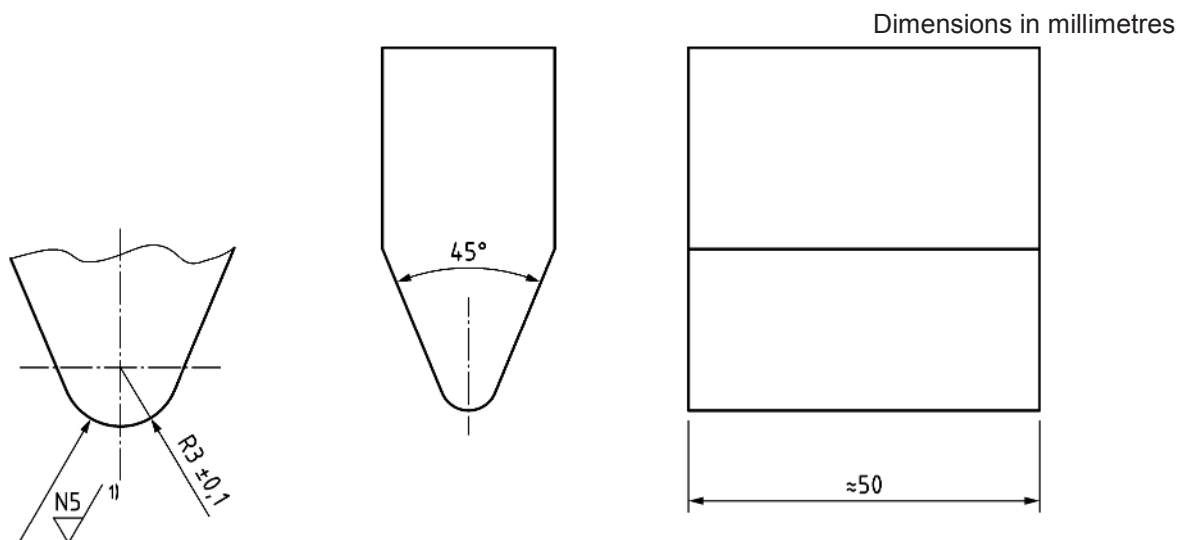

¹⁾ The roughness grade N5 in accordance with EN ISO 1302 corresponds to a roughness value R_a of $0,4 \mu\text{m}$.

Figure A.2 — Abrading tool

A.3 Test pieces

Each test piece shall be a sample of hose of length $150 \text{ mm} \pm 0,5 \text{ mm}$. A minimum of three test pieces shall be tested.

NOTE Selection of test pieces is permitted to ensure that there are no surface irregularities greater than $0,5 \text{ mm}$ and that they are free from surface contamination.

A.4 Condition of test pieces

No test shall be carried out within 24 h of manufacture. For evaluations which are intended to be comparable, the test shall, as far as possible, be carried out after the same time interval after manufacture. Before testing,

test pieces shall be conditioned for at least 3 h at the standard temperature and humidity of $23\text{ °C} \pm 2\text{ °C}$ and $(50 \pm 5)\%$ relative humidity or $27\text{ °C} \pm 2\text{ °C}$ and $(65 \pm 5)\%$ relative humidity, in accordance with ISO 23529; this 3 h period may be part of the 24 h interval after manufacture.

A.5 Procedure

Weigh each test piece on or off the mandrel and record the mass (m_1). Mount the assembled test piece and mandrel in the apparatus, ensuring that the test piece is restrained from axial and/or rotational movement. Place the abrading tool in contact with the test piece, apply the vertical static force F as specified in this product standard, and start the machine. Continue until the specified number of cycles has been completed, then remove the test assembly from the apparatus and reweigh the test piece, either on or off the mandrel, as for the initial weighing. It is important to remove any loose particles of cover compound prior to weighing. Record the mass (m_2) and the number of cycles completed.

For guidance in preparing requirements in product standards, the static force should be 50 N or 100 N, the latter being selected where higher abrasion resistance if the cover is expected. If it becomes evident during the test that wear has taken place to an extent that the reinforcement is exposed, stop the test, remove the test assembly from the apparatus and reweigh. Record the mass and the number of cycles completed. All weighings shall be carried out to an accuracy of $\pm 0,01\text{ g}$.

A.6 Expression of results

The loss of mass Δm , in grams, is given by the formula:

$$\Delta m = m_1 - m_2$$

where

m_1 is the mass, in grams, of the test piece before testing;

m_2 is the mass, in grams, of the test piece after testing.

A.7 Test report

The test report shall include the following information:

- a) a reference to this European Standard;
- b) a full description of the hose tested;
- c) the temperature at which the test was carried out;
- d) the number of cycles specified;
- e) the number of cycles completed on each test piece;
- f) the vertical static force F applied;
- g) the mass of each test piece before the test;
- h) the mass of each test piece after completion of the specified number of cycles or after discontinuation of the test;

- i) the loss of mass from each test piece;
- j) the average loss in mass of the three (or more) test pieces;
- k) any observations on the nature of wear, particularly any evidence of exposure of reinforcement;
- l) the date of the test.

Annex B
(normative)

Type and routine testing of production hoses

Property	Type tests Frequency (for each hose type and size): at initial product qualification, in the event of product changes after initial qualification and after 5 years	Routine tests Performed on each length of finished hose prior to warehousing or sale
Dimensions		
Measurement of inside diameter	X	X
Measurement of outside diameter	X	X
Measurement of outer cover thickness (if applicable – see Table 1)	X	N/A
Measurement of concentricity	X	N/A
Hose tests		
Proof test	X	X
Burst test	X	N/A
Minimum bend radius test	X	N/A
Change in length test (see 6.1.2)	X	X
Impulse test	X	N/A
Leakage test (hose assemblies)	X	N/A
Cold flexibility test	X	N/A
Adhesion (cover)	X	N/A
Adhesion (lining)	X	N/A
Vacuum resistance test	X	N/A
Fluid resistance test for cover	X	N/A
Fluid resistance test for lining	X	N/A
Ozone resistance test	X	N/A
Visual examination	X	X
X Test shall be carried out. N/A Test not applicable.		

Annex C
(informative)

Production acceptance testing

Property	Productions tests	
	Frequency: every 3 000 m produced of each hose type and size	Frequency: every 12 months of production for each hose type and size
Dimensions		
Measurement of inside diameter	X	X
Measurement of outside diameter	X	X
Measurement of outer cover thickness (if applicable – see Table 1)	X	X
Measurement of concentricity	X	X
Hose tests		
Proof test	X	X
Burst test	X	X
Minimum bend radius test	N/A	X
Change in length test (see 6.1.2)	X	X
Impulse test	N/A	X
Leakage test (hose assemblies)	N/A	X
Cold flexibility test	N/A	X
Adhesion (cover)	N/A	X
Adhesion (lining)	N/A	X
Vacuum resistance test	N/A	X
Fluid resistance test for cover	N/A	X
Fluid resistance test for lining	N/A	X
Ozone resistance test	N/A	X
Visual examination	X	X
X Test shall be carried out. N/A Test not applicable.		

British Standards Institution (BSI)

BSI is the national body responsible for preparing British Standards and other standards-related publications, information and services.

BSI is incorporated by Royal Charter. British Standards and other standardization products are published by BSI Standards Limited.

About us

We bring together business, industry, government, consumers, innovators and others to shape their combined experience and expertise into standards-based solutions.

The knowledge embodied in our standards has been carefully assembled in a dependable format and refined through our open consultation process. Organizations of all sizes and across all sectors choose standards to help them achieve their goals.

Information on standards

We can provide you with the knowledge that your organization needs to succeed. Find out more about British Standards by visiting our website at bsigroup.com/standards or contacting our Customer Services team or Knowledge Centre.

Buying standards

You can buy and download PDF versions of BSI publications, including British and adopted European and international standards, through our website at bsigroup.com/shop, where hard copies can also be purchased.

If you need international and foreign standards from other Standards Development Organizations, hard copies can be ordered from our Customer Services team.

Subscriptions

Our range of subscription services are designed to make using standards easier for you. For further information on our subscription products go to bsigroup.com/subscriptions.

With **British Standards Online (BSOL)** you'll have instant access to over 55,000 British and adopted European and international standards from your desktop. It's available 24/7 and is refreshed daily so you'll always be up to date.

You can keep in touch with standards developments and receive substantial discounts on the purchase price of standards, both in single copy and subscription format, by becoming a **BSI Subscribing Member**.

PLUS is an updating service exclusive to BSI Subscribing Members. You will automatically receive the latest hard copy of your standards when they're revised or replaced.

To find out more about becoming a BSI Subscribing Member and the benefits of membership, please visit bsigroup.com/shop.

With a **Multi-User Network Licence (MUNL)** you are able to host standards publications on your intranet. Licences can cover as few or as many users as you wish. With updates supplied as soon as they're available, you can be sure your documentation is current. For further information, email bsmusales@bsigroup.com.

BSI Group Headquarters

389 Chiswick High Road London W4 4AL UK

Revisions

Our British Standards and other publications are updated by amendment or revision.

We continually improve the quality of our products and services to benefit your business. If you find an inaccuracy or ambiguity within a British Standard or other BSI publication please inform the Knowledge Centre.

Copyright

All the data, software and documentation set out in all British Standards and other BSI publications are the property of and copyrighted by BSI, or some person or entity that owns copyright in the information used (such as the international standardization bodies) and has formally licensed such information to BSI for commercial publication and use. Except as permitted under the Copyright, Designs and Patents Act 1988 no extract may be reproduced, stored in a retrieval system or transmitted in any form or by any means – electronic, photocopying, recording or otherwise – without prior written permission from BSI. Details and advice can be obtained from the Copyright & Licensing Department.

Useful Contacts:

Customer Services

Tel: +44 845 086 9001

Email (orders): orders@bsigroup.com

Email (enquiries): cservices@bsigroup.com

Subscriptions

Tel: +44 845 086 9001

Email: subscriptions@bsigroup.com

Knowledge Centre

Tel: +44 20 8996 7004

Email: knowledgecentre@bsigroup.com

Copyright & Licensing

Tel: +44 20 8996 7070

Email: copyright@bsigroup.com



...making excellence a habit.™