

BS EN 840-5:2012



BSI Standards Publication

Mobile waste and recycling containers

Part 5: Performance requirements and test methods

bsi.

...making excellence a habit.™

National foreword

This British Standard is the UK implementation of EN 840-5:2012. It supersedes BS EN 840-5:2004, which is withdrawn.

The UK participation in its preparation was entrusted to Technical Committee B/508/1, Waste containers and associated lifting devices on refuse collection vehicles.

A list of organizations represented on this committee can be obtained on request to its secretary.

This publication does not purport to include all the necessary provisions of a contract. Users are responsible for its correct application.

© The British Standards Institution 2012.
Published by BSI Standards Limited 2012.

ISBN 978 0 580 72436 7

ICS 13.030.40

Compliance with a British Standard cannot confer immunity from legal obligations.

This British Standard was published under the authority of the Standards Policy and Strategy Committee on 31 January 2013.

Amendments issued since publication

Date	Text affected
------	---------------

EUROPEAN STANDARD

EN 840-5

NORME EUROPÉENNE

EUROPÄISCHE NORM

December 2012

ICS 13.030.40

Supersedes EN 840-5:2004

English Version

Mobile waste and recycling containers - Part 5: Performance requirements and test methods

Conteneurs roulants à ordures ménagères et recyclables -
Partie 5 : Exigences de performance et méthodes d'essais

Fahrbare Abfall- und Wertstoffbehälter - Teil 5:
Anforderungen an die Ausführung und Prüfverfahren

This European Standard was approved by CEN on 22 September 2012.

CEN members are bound to comply with the CEN/CENELEC Internal Regulations which stipulate the conditions for giving this European Standard the status of a national standard without any alteration. Up-to-date lists and bibliographical references concerning such national standards may be obtained on application to the CEN-CENELEC Management Centre or to any CEN member.

This European Standard exists in three official versions (English, French, German). A version in any other language made by translation under the responsibility of a CEN member into its own language and notified to the CEN-CENELEC Management Centre has the same status as the official versions.

CEN members are the national standards bodies of Austria, Belgium, Bulgaria, Croatia, Cyprus, Czech Republic, Denmark, Estonia, Finland, Former Yugoslav Republic of Macedonia, France, Germany, Greece, Hungary, Iceland, Ireland, Italy, Latvia, Lithuania, Luxembourg, Malta, Netherlands, Norway, Poland, Portugal, Romania, Slovakia, Slovenia, Spain, Sweden, Switzerland, Turkey and United Kingdom.



EUROPEAN COMMITTEE FOR STANDARDIZATION
COMITÉ EUROPÉEN DE NORMALISATION
EUROPÄISCHES KOMITEE FÜR NORMUNG

Management Centre: Avenue Marnix 17, B-1000 Brussels

Contents

Page

Foreword.....	3
1 Scope	4
2 Normative references	4
3 Terms and definitions	4
4 Tests	4
5 Test report	20
Annex A (informative) Slope and stop for "kerb travel" test	21
Annex B (informative) Apparatus for kerb fall test	22
Annex C (informative) Apparatus for lateral impact test on inclined plane	24
Annex D (informative) Wheel Test	25
Annex E (informative) Weathering tests	26
Annex F (informative) A-Deviations	27
Bibliography	28

Foreword

This document (EN 840-5:2012) has been prepared by Technical Committee CEN/TC 183 “Waste management”, the secretariat of which is held by DIN.

This European Standard shall be given the status of a national standard, either by publication of an identical text or by endorsement, at the latest by June 2013, and conflicting national standards shall be withdrawn at the latest by June 2013.

Attention is drawn to the possibility that some of the elements of this document may be the subject of patent rights. CEN [and/or CENELEC] shall not be held responsible for identifying any or all such patent rights.

This document supersedes EN 840-5:2004.

Technical changes from the latest edition:

- The content was adapted to the current state of the art and revised editorially.
- Annex D and Figure D.1 have been newly included.

This European Standard is one part of the series of standards of EN 840 with the main title *Mobile waste and recycling containers* comprising the following parts:

- *Part 1: Containers with 2 wheels with a capacity up to 400 l for comb lifting devices — Dimensions and design;*
- *Part 2: Containers with 4 wheels with a capacity up to 1 300 l with flat lid(s), for trunnion and/or comb lifting devices — Dimensions and design;*
- *Part 3: Containers with 4 wheels with a capacity up to 1 300 l with dome lid(s), for trunnion and/or comb lifting devices — Dimensions and design;*
- *Part 4: Containers with 4 wheels with a capacity up to 1 700 l with flat lid(s), for wide trunnion or BG-and/or wide comb lifting devices — Dimensions and design;*
- *Part 5: Performance requirements and test methods* (the present document);
- *Part 6: Safety and health requirements.*

According to the CEN/CENELEC Internal Regulations, the national standards organisations of the following countries are bound to implement this European Standard: Austria, Belgium, Bulgaria, Croatia, Cyprus, Czech Republic, Denmark, Estonia, Finland, Former Yugoslav Republic of Macedonia, France, Germany, Greece, Hungary, Iceland, Ireland, Italy, Latvia, Lithuania, Luxembourg, Malta, Netherlands, Norway, Poland, Portugal, Romania, Slovakia, Slovenia, Spain, Sweden, Switzerland, Turkey and the United Kingdom.

1 Scope

This European Standard gives the test methods for mobile waste and recycling containers according to EN 840-1 to EN 840-4. It also gives the levels to be reached during the tests or after they have been done.

This European Standard is applicable to mobile waste and recycling containers with capacities up to 1 700 l.

2 Normative references

The following documents, in whole or in part, are normatively referenced in this document and are indispensable for its application. For dated references, only the edition cited applies. For undated references, the latest edition of the referenced document (including any amendments) applies.

EN 840-1:2012, *Mobile waste and recycling containers — Part 1: Containers with 2 wheels with a capacity up to 400 l for comb lifting devices — Dimensions and design*

EN 840-2:2012, *Mobile waste and recycling containers — Part 2: Containers with 4 wheels with a capacity up to 1 300 l with flat lid(s), for trunnion and/or comb lifting devices — Dimensions and design*

EN 840-3:2012, *Mobile waste and recycling containers — Part 3: Containers with 4 wheels with a capacity up to 1 300 l with dome lid(s), for trunnion and/or comb lifting devices — Dimensions and design*

EN 840-4:2012, *Mobile waste and recycling containers — Part 4: Containers with 4 wheels with a capacity up to 1 700 l with flat lid(s), for wide trunnion or BG- and/or wide comb lifting device — Dimensions and design*

EN 1501-1, *Refuse collection vehicles — General requirements and safety requirements — Part 1: Rear loaded refuse collection vehicles*

EN 10142, *Continuously hot-dip zinc coated low carbon steels strip and sheet for cold forming — Technical delivery conditions*

EN ISO 1461, *Hot dip galvanized coatings on fabricated iron and steel articles — Specifications and test methods (ISO 1461)*

EN ISO 2081, *Metallic and other inorganic coatings — Electroplated coatings of zinc with supplementary treatments on iron or steel (ISO 2081)*

3 Terms and definitions

For the purposes of this document, the terms and definitions according to EN 840-1:2012, EN 840-2:2012, EN 840-3:2012 and EN 840-4:2012 apply.

NOTE Terms for components of mobile waste and recycling containers and lifting devices in three languages are given in Annex A of EN 840-1:2012.

4 Tests

4.1 General

Before and after the tests a visual inspection of the container shall be done for the purpose of:

- a) checking that the container is not damaged and has no visual defect;

- b) checking that the manufacturing characteristics of the container to be tested are those specified in the standards applying to the container according to EN 840-1 to EN 840-4;
- c) comparing the condition of the container before and after the sequence of the tests.

After completing the tests some deformation of the container is permissible, however, it shall remain entirely functional.

4.2 Control before the tests

4.2.1 Visual aspects

No obvious damage, cracks, bubbles, large flashes or sharp edges shall be present. No surface defects (unsmooth areas; trails in colour) perceivable from a distance of 1 m by the naked eye shall be visible.

4.2.2 Compatibility with EN 840-1 to EN 840-4

4.2.2.1 Components

Body, lid, wheels and other fittings shall conform to the relevant container standard.

4.2.2.2 Sizes and dimensions

Functional and safety dimensions for the container and its components shall be checked according to the figures and the relevant tables of EN 840-1 to EN 840-4.

4.2.2.3 Volumes

The volumes of container shall be measured:

- a) for the body, by tank method;
- b) for the lid, by tank method;
- c) volume results in a) and b) minus any duplicated volumes.

The volumes shall be within the tolerances according to EN 840-1 to EN 840-4.

For containers according to EN 840-3 volume measurement by means of calculation is allowed.

4.2.2.4 Tank method

The test equipment shall consist of a tank with sufficient capacity to receive the container to be tested.

The test procedure is as follows:

- place the empty container in a tank, the container shall not be inclined;
- simultaneously fill the tank and the container with water at a temperature of $(15 \pm 5) ^\circ\text{C}$;
- measure the quantity of water inside the container.

Accuracy of measurement shall be $\pm 1 \%$ of the measured capacity of the container.

4.2.3 Deflection for comb lifting system

The frontal receiver shall have a horizontal deflection of no more than:

- a) 1,5 % of the length of the frontal receiver for plastic;
- b) 0,6 % of the length for steel.

For other systems the values are to be defined when the systems are standardised.

4.2.4 Masses

The tolerances on the container mass claimed are as follows: for plastic containers $\pm 5\%$ and for metal containers $\pm 10\%$.

4.2.5 Colour

The colour shall be defined and agreed between customer and supplier. For colour measurement, differences and tolerances refer to existing International Standards.

4.2.6 Marking

Marking of the container shall correspond to EN 840-1 to EN 840-4.

4.3 Control after the tests

Notwithstanding variations in deflection and sizes, it shall be possible to lift and tilt the container loaded according to 4.5 with nominal load safely on the designated lifting equipment and to move the container on its wheels.

4.4 Conditions of the test

The tests shall be carried out at the following temperatures:

- $T_1 = (23 \pm 5) ^\circ\text{C}$
- $T_2 = (-18_{-2}^0) ^\circ\text{C}$.

The minimum duration of conditioning before testing at a test temperature T_2 shall be 12 h. If the test shall be carried out outside the room conditioned at T_2 it shall be carried out within 5 min after taking the test pieces from the conditioned room. If the duration of the tests is more than 5 min, then the container shall be kept in the conditioned room for at least 15 min before a new 5 min period of testing.

For special purposes a temperature lower than $-18\text{ }^\circ\text{C}$ or higher than $23\text{ }^\circ\text{C}$ can be agreed; in this case it shall be indicated in the test report.

4.5 Test load

For the test the containers are to be filled with ballast bags of HDPE granules of 4 kg max., with granules having a density of $0,5\text{ kg/dm}^3$.

The test load shall be $0,4\text{ kg/dm}^3$ multiplied by nominal volume, but not more than 440 kg.

4.6 Other test conditions

Any other test conditions shall be defined within the tests involved.

4.7 Tests on the containers

4.7.1 General

All tests shall be carried out on new containers.

4.7.2 Impact tests by ball drop

The ball drop test is not compulsory for steel containers.

The ability of sensitive points of the container to resist impacts at low temperature shall be tested under conditions in 4.4.

The 2-wheeled containers shall be placed on a concrete or steel surface in the normal position.

There shall be a steel frame between the concrete surface or the steel surface and the container so that the complete area of the bottom of the container can be deflected during the test.

The 4-wheeled containers shall stand on their wheels.

Ball drop tests shall be carried out using a 5 kg steel cylinder, diameter 65 mm, with hemispheric end radius of 32,5 mm. The steel cylinder is guided in a vertical pipe with a slot or with holes in order to allow the air to escape during the drop.

The device shall be according to Figure 1.

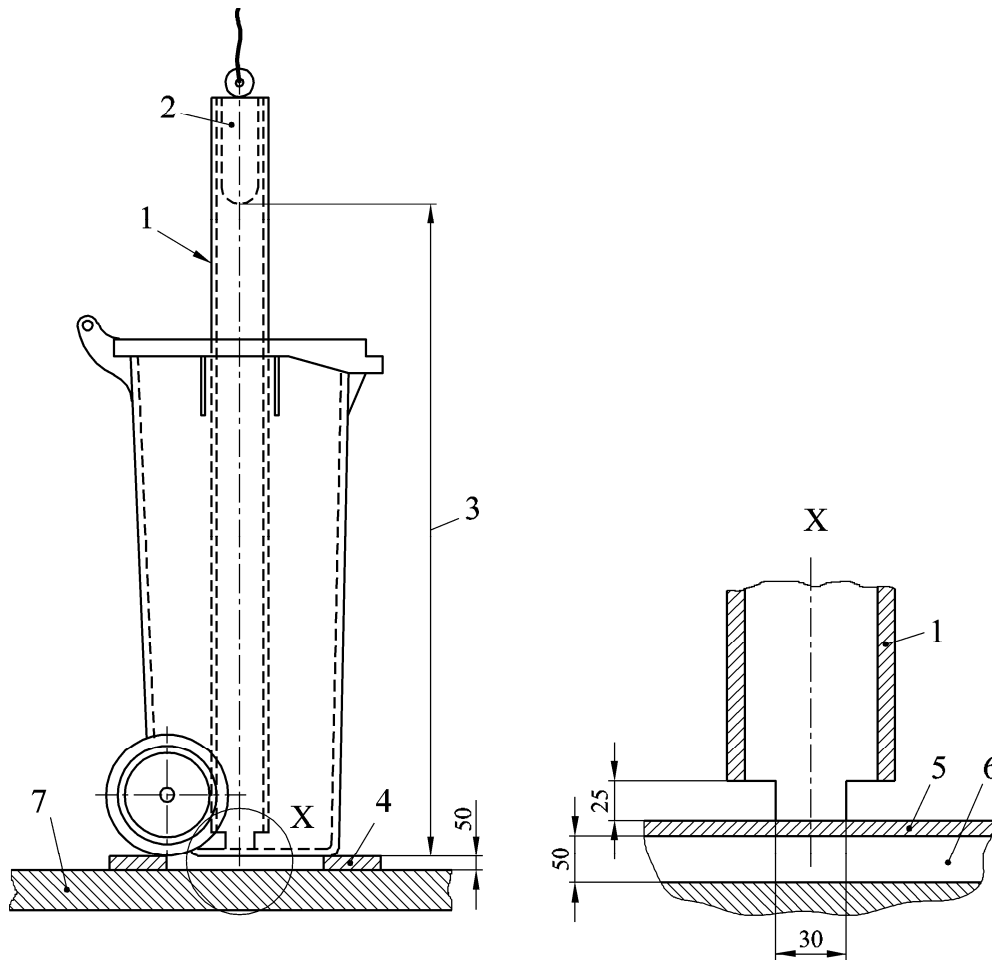

Key

- | | |
|--|-----------------------------|
| 1 vertical (plastic) pipe
(inside diameter: 70 mm) | 6 free room |
| 2 steel cylinder
(diameter: 65 mm; 1 hemispheric end; mass: 5 kg) | 7 concrete or steel surface |
| 3 height fall (0,80 m) | |
| 4 steel frame (see 4.7.2) | |
| 5 container bottom | |

Figure 1 — Device for ball drop test

The following areas of containers shall be tested by impact tests:

- a) on the body bottom (see Figure 2 d) there shall be 3 successive impacts for each impact point defined below:

- 1) the injection point(s),
- 2) A and D or C and B.

after the test the container shall be waterproof in the tested points;

- b) there shall be 2 successive impacts for each impact point defined below (see Figures 2a), 2b), 2c))

- 1) the centre of the lid (E),

- 2) one corner of the lid (cylinder to be tangent to the lid) (F),
- 3) the corner diametrically opposite (cylinder to be tangent to the lid) (G),
- 4) each hinge (H),
- 5) the centre of the front face of the top rim (J),
- 6) the centre of a lateral face of the top rim (I),
- 7) the back corner opposite the lateral face previously tested of the top rim (K),
- 8) centre of any handle (L, see Figure 2 c) key 2).

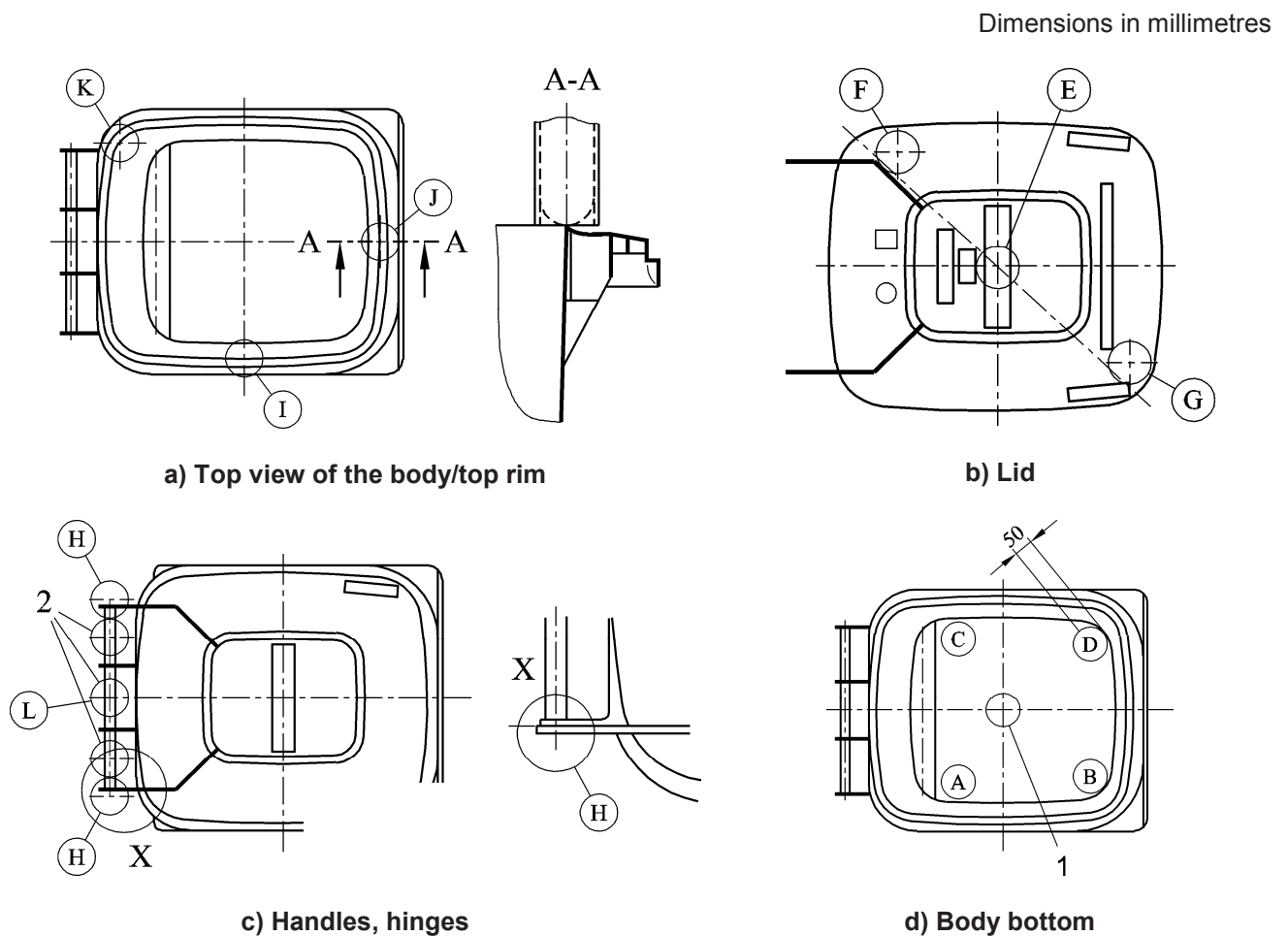

Key

- 1 injection point
(if one injection point only, impact on it and on A - D or B - C)
- 2 middle of handle

Figure 2 — Impact points for ball drop test

Outside of the conditioning room (see 4.4), the test shall not last more than 5 min. After this time the container shall be reconditioned for at least 15 min.

After the test the following procedure shall be applied, if there is any doubt about the result:

- fill the body with a water volume equal to 10 % of the maximum capacity of the body;
- wait for 10 min.

After 10 min, if the container leaks, it is declared to be non conforming.

4.7.3 Impacts on an inclined plane

Only 4-wheeled containers shall be tested with impact on each wall of the body and on each corner to check the resistance to straining and breaking of sensitive areas, including protruding areas and fittings. The test conditions shall be:

- test temperature T_1 = room temperature;
- test load according to 4.5;
- inclination of 10° (ten degrees) to the horizontal;
- impact against a wall perpendicular to the moving direction;
- a total of 16 impacts according to the sequence in Table 1.

During the procedure the lid shall be closed. The loaded container shall be placed on a trolley with an inclination of 10° (ten degrees) (relative to the horizontal). Precautions shall be taken to avoid accidental tipping of the container during the test (see Figure C.1).

Other apparatus than shown in Figure C.1 may be used if it allows the same impact and velocity conditions.

The impact velocity shall be $(1,85 \pm 0,05)$ m/s when a face is tested and $(1,3 \pm 0,05)$ m/s when a corner is tested.

The vertical faces of the container will be numbered from 1 to 4 and the face marked 1 being the large face fitted for the (comb) lifting system. Corners are marked 1.2, 2.3, 3.4 and 4.1.

Table 1 — Sequence of the lateral impacts

Impact n°	Face or corner tested	No of impacts
1 to 2	Face 1	2
3 to 4	Corner 1.2	2
5 to 6	Face 2	2
7 to 8	Corner 2.3	2
9 to 10	Face 3	2
11 to 12	Corner 3.4	2
13 to 14	Face 4	2
15 to 16	Corner 4.1	2

After completing the test some deformation of the container is permissible, however, it shall remain entirely functional.

4.7.4 Kerb travel (run)

Only 4-wheeled containers shall be tested for kerb travel using run tests under the following conditions:

- test shall be carried out at room temperature T_1 ;

- test load according to 4.5;
- apparatus shall comply with Annex A;
- kerb height shall be 140 mm orthogonal to the moving direction and located at the end of the run;
- wheels are to be guided in order to be orthogonal to the kerb at the time of the impact;
- impact velocity shall be $(1,85 \pm 0,05)$ m/s;
- there shall be 4 impacts for each of the shorter ends of the container (8 in total).

After the test there shall be no permanent deformation or breakage which disturbs handling, tilting, rolling (castors move freely).

4.7.5 Kerb travel (falls)

4.7.5.1 General

Strength tests shall be carried out on 2- and 4-wheeled containers under the following conditions:

- test temperature T_1 = room temperature;
- test load according to 4.5;
- height fall of 140 mm.

The container shall be lifted up to 140 mm and then dropped freely so that 2 wheels hit the ground first.

After the test there shall be no permanent deformation or breakage, which disturbs handling, tilting, rolling or safety and health (castors shall move freely).

4.7.5.2 Test conditions

- 2 wheels shall hit the ground;
- at least 1 000 drops shall be carried out;
- number of 5 drops per minute maximum;
- test apparatus shall be according to Figure B.1 and B.2.

After the test there shall be no permanent deformation or breakage which disturbs handling, tilting, rolling (castors move freely).

4.8 Stability test

The static stability of empty and loaded containers on a flat plane of 10° (ten degrees) to the horizontal shall be tested at first on empty containers and after that on containers filled with the nominal load.

The test shall be carried out without wind.

For 4-wheeled containers, the brakes, if any, could prevent them from rolling. Other arrangements shall be made to prevent containers from gliding or rolling without hindering tipping.

The container shall be checked in 3 directions.

- a) Stability at right angles to the slope line (transversal stability):
the wider part of 4-wheeled containers and the wheel's axle of 2-wheeled containers shall be parallel to the slope line.
- b) Longitudinal stability:
the wider part of 4-wheeled containers and the wheel's axle of 2-wheeled containers shall be in the right angle to the slope line.
- c) Diagonal stability:
the diagonal line of the container shall be parallel to the slope line.

The longitudinal stability test of 4-wheeled containers includes the brake test according to 4.9.4. In consideration of all test conditions the container shall neither tip nor move.

4.9 Pulling and rolling tests

4.9.1 General

The aim of these tests is to check the handling and immobilisation of the containers and to fulfil the safety and health requirements for the operators.

These tests shall include:

- pulling tests;
- wheels tests;
- brake tests.

4.9.2 Pulling tests

The strength required to start and maintain the container movement shall be measured (regarding the apparatus, see Figure 3).

Dimensions in millimetres

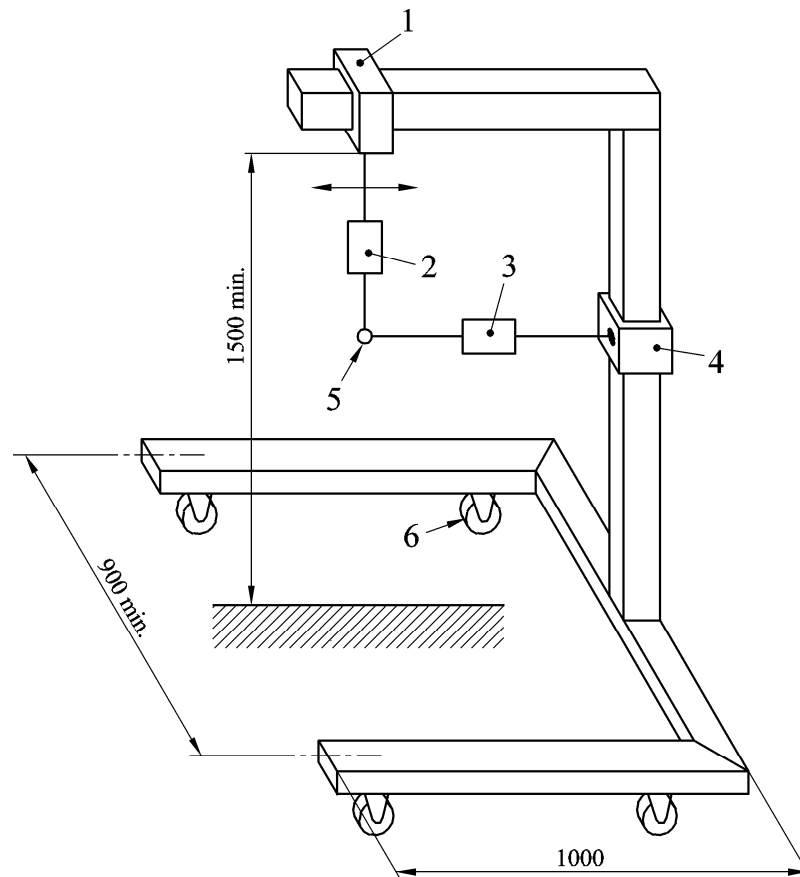

Key

- 1 adjuster
- 2 measuring head for handle lifting force
(20 % of container dead weight)
- 3 measuring head for pulling force in rigid and hinged fittings
- 4 adjuster for the handle height
- 5 handle of container
(2-wheeled container in tilted position)
- 6 swivel castors with direction block

NOTE By using the above testing tool the horizontally measured pulling force is ensured.

Figure 3 — Apparatus for measurement (Example of testing device of 2-wheeled container)

The pulling forces defined as horizontal forces in pulling direction are measured and the result shall be stated in the instructions for use.

In order to get comparable results all tests shall be carried out under the following conditions:

- a) new container (loaded according to 4.5);
- b) ground shall be a plane, smooth concrete horizontal surface (slope = 1° (one degree) maximum);
- c) pulling force direction shall be horizontal $\pm 2^\circ$ (two degrees) to all sides;
- d) pulling speed shall be 0,1 m/s \pm 0,005 m/s;

- e) pulling distance shall be 3 m minimum;
- f) temperature in the test area and of the tested container shall be T_1 ;
- g) total tolerance range of measuring equipment shall be $\pm 3\%$ of the measured value;
- h) preparation of the tested container before every test shall be:
 - 1) 2-wheeled containers shall be in a tilted position where the strength for a handle is 20 % of the force (Newton), created by the container's total permissible mass (kilograms),
 - 2) 4-wheeled containers shall have the wheels aligned in the pulling direction. The direction block, if fitted, shall be in operation;
- i) tests shall be carried out 3 times.

Table 2 — Maximum forces for sustained pulling (up to 1 700 l capacity)

Container	Pulling force N max.
2-wheeled	60
4-wheeled	285
Maximum forces (including initial force) ought to be no more than 300 N, according to some work regulations.	

4.9.3 Wheels testing

The functional qualities of the wheels over a given distance, at a defined speed, under load, with a periodical step shall be tested. It is a test specifically for the wheel.

The apparatus shall be a concrete surface horizontal circle with a diameter of 1,1 m.

The wheel is rolled in a circle. A step of 11,5 cm height is placed in the circle along a radius and allows the wheel to fall down after each 3,5 m run (1 turn). The wheel is loaded with loads according to Table 3. The test shall be carried out in turns of moving and rest.

Table 3 — Conditions for testing wheels (200 mm diameter)

Conditions	Wheels for 2-wheeled containers	Wheels for 4-wheeled containers
Number of wheels	2 consecutively	2 consecutively
Load per wheel	40 kg	65 kg
Cycles running time	1 min	5 min
Resting time and again	3 min	5 min
Total distance run	5 km	20 km
Equivalent time	1,5 h	–
Running speed	3,3 km/h	3,3 km/h
Checking of the wheel	at the end of the test	every 3 h

The test shall be carried out at temperature T_1 .

After completing the test tyres and wheels shall remain functional.

After the test there shall be no permanent deformation or breakage, which disturbs handling, tilting, rolling. (castors shall move freely). The hub shall be fully intact with no loosening or breaking of rivets.

4.9.4 Brake tests

The container shall not roll on a gradient of 10° to the horizontal under all load conditions.

4.10 Lifting-tilting tests

4.10.1 General

This test checks that the container fits well on lifting devices in agreement with EN 1501-1. The apparatus shall be a compatible standardised lifting device. All lifting attachments of the container shall be tested.

The container and the lifting device are on the same plane, on even ground. The test should be carried out under normal service conditions.

4.10.2 Lifting-tilting of the empty container

This is a preliminary test to be done after visual inspection of the container and before the other tests.

The test is carried out on an empty container successively with the lid closed.

A minimum of 5 lifting-tilting cycles should be completed without damage or malfunction.

After completing the tests no damage on any part of the containers, lid, etc, shall be visible with the naked eye. No hindering during the cycles is allowed. If unsuccessful, the test shall be stopped.

4.10.3 Lifting-tilting of the loaded container

The test shall be carried out on one sample under the following conditions:

- test load shall conform to 4.5. A device to prevent the test load from being ejected during the test;
- test temperature T_1 ;
- at least 100 cycles shall be made.

After every 10 cycles a break of 5 min is planned.

After completing the test it shall be possible to safely position the container on the lifting device without lifting it by hand.

The container shall be locked safely when tilting, during the cycles.

After completing the test no permanent deformation or abnormal distortion of the container causing premature ageing and no changes in dimensions that would give handling and lifting difficulties shall appear.

4.11 Miscellaneous tests

4.11.1 Internal stress-cracking tests (for thermo plastics only)

The following procedure tests the level of internal stress which can affect some molded plastic parts. Cracks after this test mean use of inadequate material or bad processing conditions.

The test shall be carried out under the following conditions:

- tank large enough to include the whole container;
- water bath with 2 % to 3 % in volume of active part strong detergent e. g.¹⁾ diluted in water;
- bath temperature of $(70 \pm 5)^\circ\text{C}$;
- duration of the bath shall be 48 h.

After the test the container shall be rinsed immediately and shall be checked visually only 6 h after the test.

After completing the test no cracks or tears in sensitive areas (containers and lids) where they could extend to bring the container out of use, e.g. front rim, handles, grip hinges, wheel junctions, hinges, injection points, reinforcing ribs, rib edges shall be visible.

For containers with four wheels a test of segments is allowed with segments of approximately a quarter of a square meter. For the detergent test the following critical area should be sawed from the container and should be tested in accordance with 4.11.1:

- Wheel suspension (see area 1 in Figure 4): The wheel bracket is to be cut out from the bottom at a height of approx. 500 mm. All wheel suspensions including the screwed in fastening elements and the drain sleeve shall be tested.
- Frontal receiver (see area 2 in Figure 4): Both corner parts are to be checked. The area should be 300 mm x 300 mm large.

1) A suitable detergent is nonyl-phenol-etoilate with a number of ethylene oxide (EO) mol greater than or equal to 9.

- Hinge area (see area 3 in Figure 4): Both corner parts are to be checked. The area should be 300 mm x 300 mm large.
- Lid (see area 4 in Figure 4): An area from the hinges to the injection points is to be tested.

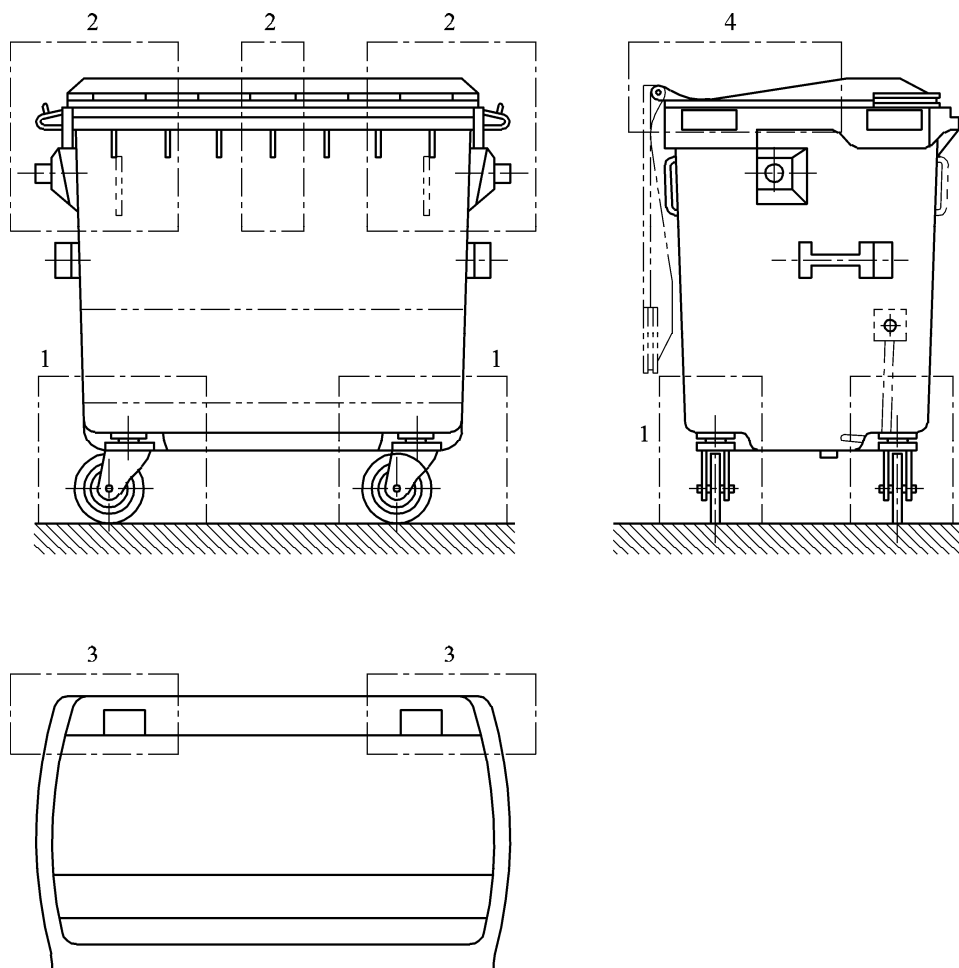

Figure 4 — Segments to be tested

4.11.2 Handle test

Lifting handles on 4-wheeled containers shall be tested.

Lifting handles and their junction with the container shall be strong enough to avoid damage or disconnecting when they are used to lift the container up the kerb.

The test shall be carried out under the following conditions:

- test temperature T_1 ;
- test load shall conform to 4.5;
- lifting height shall be minimum 50 mm;
- test frequency shall be 5 times per minute with a number of 1 000 liftings at least.

The container shall be lifted at least 50 mm by a 50 mm wide hook which is located around the middle of the handle, and afterwards is slowly moved down to the ground.

After the test there shall be no permanent deformation or breakage, which disturbs handling the container.

4.11.3 Corrosion test

The container shall be resistant to corrosion due to the state of the art.

It is the task of the manufacturer to use surface treatments or materials which guarantee this performance.

Bodies and lids, hot dip galvanised after completion, and other hot dip galvanised parts shall meet the requirements of EN ISO 1461.

Zinc electro-plated parts shall meet the requirements of EN ISO 2081.

Weldless bodies, lids and parts made out of continuously hot-dip zinc coated steel sheets shall meet the requirements of EN 10142.

4.11.4 Weathering (for thermo plastics only)

Preparation of samples, conditions of exposures, sequence of exposures, test methods to measure performances of new and irradiated samples are defined in standards to be established by CEN/TC 249. In the meantime, ISO standards may be used (see Annex E).

The material tested shall contain all the components added to the basic plastic at the rate used to mold the container, stabiliser, pigments or colorants, and, if any, fillers, other plastic etc. These additives may influence the effects of weathering on the plastic.

The results of weathering on plastic containers shall include:

- ageing of the plastic material;
- changes in colour.

4.11.5 Test method for dome lid container (EN 840-3)

4.11.5.1 Equipment

- A child mannequin in compliance with an appropriate European Regulation²⁾; size corresponding to 10 years old. The child mannequin is dressed with a thin sweatshirt made of at least 90 % cotton. The child mannequin is wearing the hood.
- A parallel piped-shaped plastic box (dimensions: length 600 mm x width 400 mm x height 320 mm).

4.11.5.2 Test method

The test described below shall be performed five times for each of the following three child mannequin positions in relation to the container rim:

- center;
-

2) ECE R44:

European Regulation N° 44 incl. amendment 1; *Uniform provisions concerning the approval of retaining devices for child occupants of power-driven vehicles ('child restraints systems')*.

- left hand side;
- right hand side.

The untested dome lid braked container is placed on a hard concrete plane with an inclination of 1° maximum to the horizontal.

Position the legs of the child mannequin on the plastic box, such that the head and arms are inside the container for the centre position and one arm inside the container for the lateral position. Close the lid manually until it stops without any unlocking. Remove the box by device at a speed of 0,5 m/s.

4.11.5.3 Acceptance criteria

In each of the three positions, in any sequence of the test, the child mannequin shall fall from the container when the plastic box is removed.

It is acceptable for the child mannequin's head to remain suspended for an amount of time not to exceed 2 s.

4.11.6 Sequence of the tests

The sequence of the tests on each sample are defined by Table 4.

Table 4 — Sequence of the tests

Subclause	Test	2-wheeled containers					4-wheeled containers						
		Sample 1		Sample 2		Other samples	Sample 1		Sample 2		Sample 3		Other samples
		plastic	metal	plastic	metal		plastic	metal	plastic	metal	plastic	metal	
4.2.1	General inspection	0	0	–	–	–	0	0	–	–	–	–	–
4.2.2.2	Measurement	1	1	–	–	–	1	1	–	–	–	–	–
4.7.1	Ball drop	–	–	1	–	–	–	–	1	–	–	–	–
4.7.2	Impact	–	–	–	–	–	8	8	–	–	–	–	–
4.7.3	Kerb run	–	–	–	–	–	9	9	–	–	–	–	–
4.7.4	Kerb falls	6	6	–	–	–	–	–	–	1	1	–	–
4.8	Stability	4	4	–	–	–	4	4	–	–	–	–	–
4.9.2	Pulling	2	2	–	–	–	2	2	–	–	–	–	–
4.9.3	Wheels	–	–	–	–	wheels sample	–	–	–	–	–	–	wheels sample
4.9.4	Brakes	–	–	–	–	–	5	5	–	–	–	–	–
4.10.2	Lifting empty	3	3	–	–	–	3	3	–	–	–	–	–
4.10.3	Lifting loaded	5	5	–	–	–	7	7	–	–	–	–	–
4.11.1	Internal stress	–	–	z	–	S	–	–	z	–	–	–	S
4.11.2	Handles	–	–	–	–	–	6	6	–	–	–	–	–
4.11.3	Corrosion	–	–	2	2	section	–	–	2	2	–	–	–
4.11.4	Weathering	–	–	–	–	S	–	–	–	–	–	–	S
4.11.5	Dome lid	–	–	–	–	–	1	1	–	–	–	–	–

S special new parts:
 - for internal stress: on body and lid
 - for weathering: on body and lid, or parts of them, or standardised samples

Testing unit: - for 2-wheeled containers 2 regular samples and 2 special ones are required;
- for 4-wheeled containers 3 regular samples and 2 special ones are required.

5 Test report

The test report shall include the following:

- a) name and place of the testing body;
- b) testing date;
- c) test conditions according to EN 840-5;
- d) description of the tested containers (manufacturer, designation, others);
- e) number of the containers tested (see 4.11.6);
- f) type of testing equipments;
- g) stipulated values mentioned in 4.7.2, 4.7.3, 4.7.4, 4.9.2 and the stipulated corrosion or/and weathering test for materials different from galvanised steel and polyethylene;
- h) result on each test.

Annex A (informative)

Slope and stop for "kerb travel" test

Dimensions in millimetres

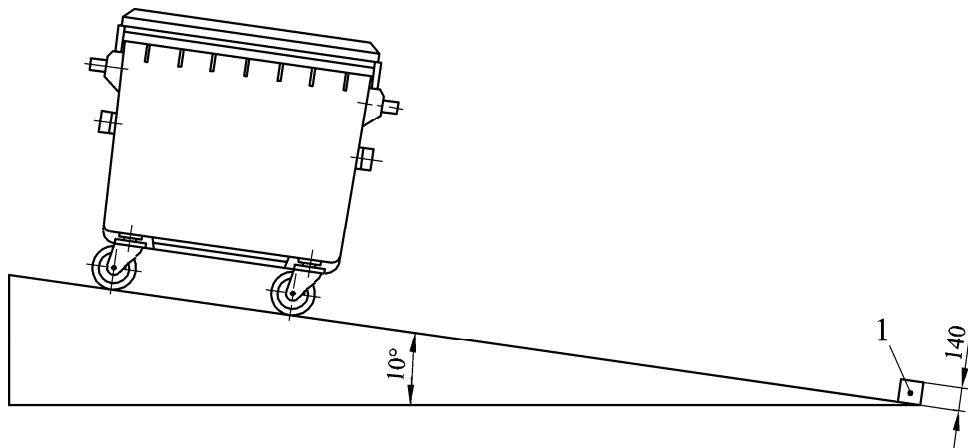

Key

1 stop

Run to be adjusted to reach an impact velocity of 1,85 m/s at stop.

Figure A.1 — Device for "kerb travel" test

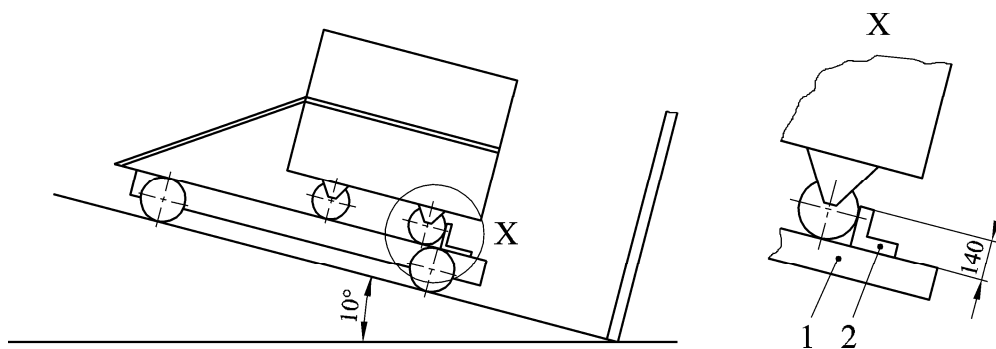

Key

1 trolley

2 steel angle

Figure A.2 — Other equipment for "kerb travel" test

Annex B
(informative)

Apparatus for kerb fall test

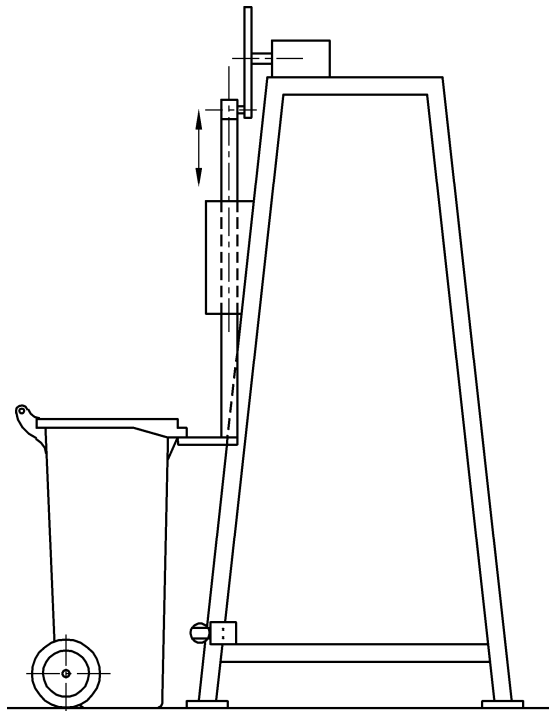

Figure B.1 — Apparatus for kerb fall test, 2-wheeled container

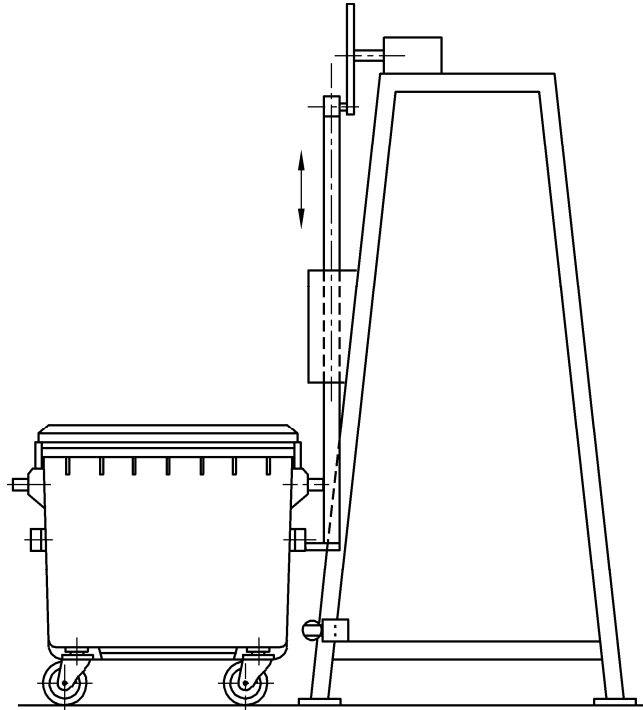
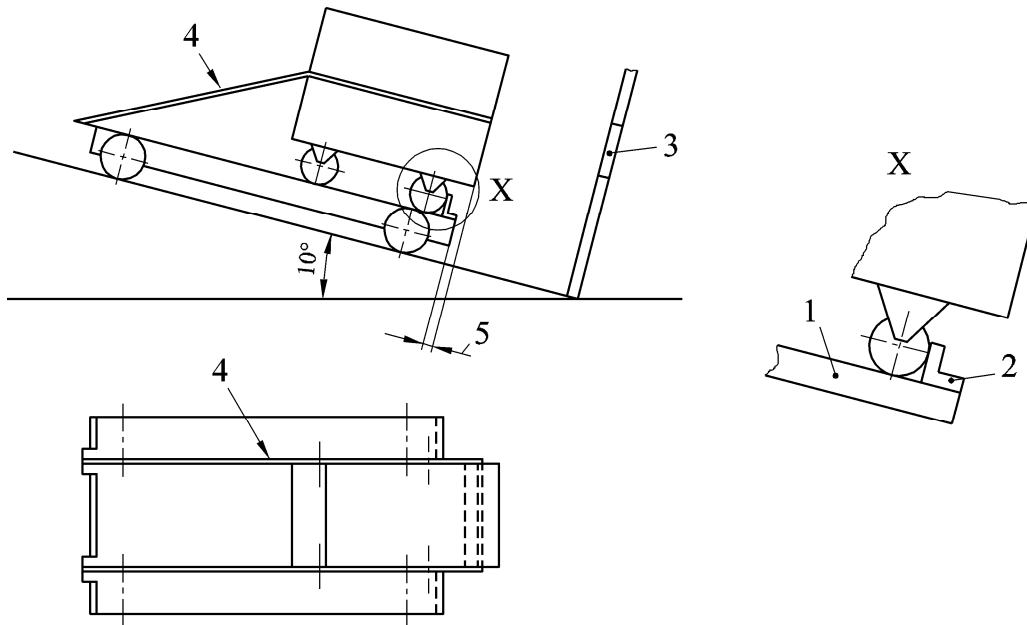

Figure B.2 — Apparatus for kerb fall test, 4-wheeled container

Annex C (informative)

Apparatus for lateral impact test on inclined plane

Suggested precautions taken to avoid accidental tipping from trolley during the lateral impact test on inclined plane.



Key

- 1 trolley
- 2 steel angle
- 3 hole to allow the trunnion to pass through
- 4 ties
- 5 overhang

Figure C.1 — Apparatus for lateral impact test on inclined plane

Annex D (informative)

Wheel Test

Dimensions in millimetres

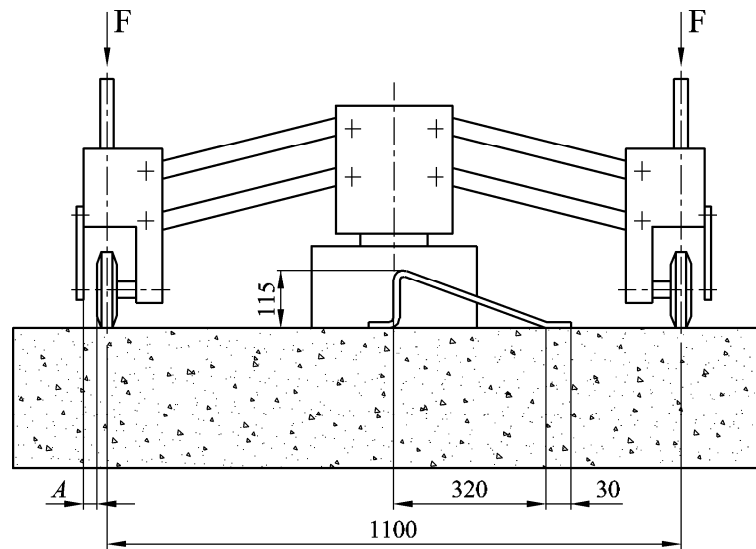

The concrete floor has a thickness of ≥ 200 mm
The surface has a size of at least 1 300 mm x 1 300 mm

"A" is the space between the wheel (the swivel castor) and a security part, which makes sure that the wheel not completely fall down from the axle, and that the swivel castor cannot turn a round more than 10 mm.

A = 10 mm for swivel castor (4 wheeled container)

A = 25 mm for wheels (2 wheeled container)

Figure D.1 — Apparatus for wheel test

Annex E (informative)

Weathering tests

Weathering tests can be carried out as:

- a) outdoor weathering:
 - 1) exposure of containers and samples (according to EN ISO 4892-2),
 - 2) in an area giving, at least, the radiation foreseen in use. (For instance total 0,8 MWs/cm² in 3 years is 64 kLy: Northern Europe);
- b) artificial (accelerated) weathering test
(xenotest - according to EN ISO 4892-2).

Though correlation between the results with "natural" and "artificial" experiences is difficult; 2 000 h of xenon-arc radiation is needed to have roughly a total irradiation of 0,8 MWs/cm².

Result:

After testing with specimen of 3 mm thickness, the value of the impact tensile strength should not be below 50 % of the initial value. The determination of the tensile-impact strength should be effected on sample-type 3 according to EN ISO 8256.

To estimate the resistance of the colour to bleaching according to EN ISO 105-B02, the colour contrast should not exceed level four.

Annex F (informative)

A-Deviations

A-Deviation: National deviation due to regulations, the alteration of which is for the time being outside the competence of the CEN-CENELEC-member.

This European Standard does not fall under any Directive of the EU. In the relevant CEN-CENELEC-countries these A-deviations are valid instead of the fixations of the European Standard until they have been removed.

DENMARK

EN 840-1 to EN 840-6 do not fulfil the national Danish legislation regarding requirements for health and safety. This legislation is based on EEC-Directive 89/391/EC of 12 June 1989 and EEC-Directive 90/269/EEC of 29 May 1990.

The Danish legislation is written down in "Executive Order No. 867 of 13 October 1994 concerning Performance of Work" and in "Executive Order No. 1164 of 16 December 1994 concerning Manual Handling" both given by the Minister of Work. The Legal understanding of the Executive Orders are written in the Danish Working Environment Service (WES) guidelines. WES-guideline No. 4.1.0.1 of 1993 describes "Manual handling and transportation of domestic garbage" and No. 4.1.0.2 of 1996 describes "Construction of technical systems and equipment for handling domestic garbage" (former WES circular-order No. 10/1990).

Therefore the manual handling and use of containers described in EN 840-1 to EN 840-6 can be met in Denmark with additional requirements.

Bibliography

- [1] EN ISO 105-B02, *Textiles — Tests for colour fastness — Part B02: Colour fastness to artificial light: Xenon arc fading lamp test (ISO 105-B02)*
- [2] EN ISO 4892-2, *Plastics — Methods of exposure to laboratory light sources — Part 2: Xenon-arc lamps (ISO 4892-2)*
- [3] EN ISO 8256, *Plastics — Determination of tensile-impact strength (ISO 8256)*
- [4] European Regulation ECE R44, *Uniform provisions concerning the approval of retaining devices for child occupants of power driven vehicles ('child restraints systems')*

British Standards Institution (BSI)

BSI is the national body responsible for preparing British Standards and other standards-related publications, information and services.

BSI is incorporated by Royal Charter. British Standards and other standardization products are published by BSI Standards Limited.

About us

We bring together business, industry, government, consumers, innovators and others to shape their combined experience and expertise into standards-based solutions.

The knowledge embodied in our standards has been carefully assembled in a dependable format and refined through our open consultation process. Organizations of all sizes and across all sectors choose standards to help them achieve their goals.

Information on standards

We can provide you with the knowledge that your organization needs to succeed. Find out more about British Standards by visiting our website at bsigroup.com/standards or contacting our Customer Services team or Knowledge Centre.

Buying standards

You can buy and download PDF versions of BSI publications, including British and adopted European and international standards, through our website at bsigroup.com/shop, where hard copies can also be purchased.

If you need international and foreign standards from other Standards Development Organizations, hard copies can be ordered from our Customer Services team.

Subscriptions

Our range of subscription services are designed to make using standards easier for you. For further information on our subscription products go to bsigroup.com/subscriptions.

With **British Standards Online (BSOL)** you'll have instant access to over 55,000 British and adopted European and international standards from your desktop. It's available 24/7 and is refreshed daily so you'll always be up to date.

You can keep in touch with standards developments and receive substantial discounts on the purchase price of standards, both in single copy and subscription format, by becoming a **BSI Subscribing Member**.

PLUS is an updating service exclusive to BSI Subscribing Members. You will automatically receive the latest hard copy of your standards when they're revised or replaced.

To find out more about becoming a BSI Subscribing Member and the benefits of membership, please visit bsigroup.com/shop.

With a **Multi-User Network Licence (MUNL)** you are able to host standards publications on your intranet. Licences can cover as few or as many users as you wish. With updates supplied as soon as they're available, you can be sure your documentation is current. For further information, email bsmusales@bsigroup.com.

BSI Group Headquarters

389 Chiswick High Road London W4 4AL UK

Revisions

Our British Standards and other publications are updated by amendment or revision.

We continually improve the quality of our products and services to benefit your business. If you find an inaccuracy or ambiguity within a British Standard or other BSI publication please inform the Knowledge Centre.

Copyright

All the data, software and documentation set out in all British Standards and other BSI publications are the property of and copyrighted by BSI, or some person or entity that owns copyright in the information used (such as the international standardization bodies) and has formally licensed such information to BSI for commercial publication and use. Except as permitted under the Copyright, Designs and Patents Act 1988 no extract may be reproduced, stored in a retrieval system or transmitted in any form or by any means – electronic, photocopying, recording or otherwise – without prior written permission from BSI. Details and advice can be obtained from the Copyright & Licensing Department.

Useful Contacts:

Customer Services

Tel: +44 845 086 9001

Email (orders): orders@bsigroup.com

Email (enquiries): cservices@bsigroup.com

Subscriptions

Tel: +44 845 086 9001

Email: subscriptions@bsigroup.com

Knowledge Centre

Tel: +44 20 8996 7004

Email: knowledgecentre@bsigroup.com

Copyright & Licensing

Tel: +44 20 8996 7070

Email: copyright@bsigroup.com



...making excellence a habit.™