



BSI Standards Publication

Mobile waste and recycling containers

Part 2: Containers with 4 wheels with a capacity up to 1 300 l with flat lid(s), for trunnion and/or comb lifting devices — Dimensions and design

National foreword

This British Standard is the UK implementation of EN 840-2:2012. It supersedes BS EN 840-2:2004, which is withdrawn.

The UK participation in its preparation was entrusted to Technical Committee B/508/1, Waste containers and associated lifting devices on refuse collection vehicles.

A list of organizations represented on this committee can be obtained on request to its secretary.

This publication does not purport to include all the necessary provisions of a contract. Users are responsible for its correct application.

© The British Standards Institution 2012.
Published by BSI Standards Limited 2012.

ISBN 978 0 580 72433 6

ICS 13.030.40

Compliance with a British Standard cannot confer immunity from legal obligations.

This British Standard was published under the authority of the Standards Policy and Strategy Committee on 31 December 2012.

Amendments issued since publication

Date	Text affected
------	---------------

EUROPEAN STANDARD

EN 840-2

NORME EUROPÉENNE

EUROPÄISCHE NORM

December 2012

ICS 13.030.40

Supersedes EN 840-2:2004

English Version

Mobile waste and recycling containers - Part 2: Containers with 4 wheels with a capacity up to 1 300 l with flat lid(s), for trunnion and/or comb lifting devices - Dimensions and design

Conteneurs roulants à ordures ménagères et recyclables -
Partie 3: Conteneurs à 4 roues de capacité inférieure ou
égale à 1300 l à couvercle(s) bombé(s), pour lève-
conteneurs par tourillon et/ou à peigne - Dimensions et
conception

Fahrbare Abfall- und Wertstoffbehälter - Teil 2: Behälter mit
4 Rädern und einem Nennvolumen bis 1300 l mit
Flachdeckel(n), für Schüttungen mit Zapfenaufnahme
und/oder für Kammschüttungen - Maße und Formgebung

This European Standard was approved by CEN on 22 September 2012.

CEN members are bound to comply with the CEN/CENELEC Internal Regulations which stipulate the conditions for giving this European Standard the status of a national standard without any alteration. Up-to-date lists and bibliographical references concerning such national standards may be obtained on application to the CEN-CENELEC Management Centre or to any CEN member.

This European Standard exists in three official versions (English, French, German). A version in any other language made by translation under the responsibility of a CEN member into its own language and notified to the CEN-CENELEC Management Centre has the same status as the official versions.

CEN members are the national standards bodies of Austria, Belgium, Bulgaria, Croatia, Cyprus, Czech Republic, Denmark, Estonia, Finland, Former Yugoslav Republic of Macedonia, France, Germany, Greece, Hungary, Iceland, Ireland, Italy, Latvia, Lithuania, Luxembourg, Malta, Netherlands, Norway, Poland, Portugal, Romania, Slovakia, Slovenia, Spain, Sweden, Switzerland, Turkey and United Kingdom.



EUROPEAN COMMITTEE FOR STANDARDIZATION
COMITÉ EUROPÉEN DE NORMALISATION
EUROPÄISCHES KOMITEE FÜR NORMUNG

Management Centre: Avenue Marnix 17, B-1000 Brussels

Contents

Page

Foreword.....	3
1 Scope	4
2 Normative references	4
3 Terms and definitions	4
4 Volumes	5
5 Dimensions and design	5
6 Nominal mass	6
7 Safety and health requirements	6
8 Testing	6
9 Marking	6
10 Designation	7
Annex A (informative) Recommendations for manufacturers of lifting devices	15
Annex B (informative) A-Deviations	17
Bibliography	18

Foreword

This document (EN 840-2:2012) has been prepared by Technical Committee CEN/TC 183 “Waste management”, the secretariat of which is held by DIN.

This European Standard shall be given the status of a national standard, either by publication of an identical text or by endorsement, at the latest by June 2013, and conflicting national standards shall be withdrawn at the latest by June 2013.

Attention is drawn to the possibility that some of the elements of this document may be the subject of patent rights. CEN [and/or CENELEC] shall not be held responsible for identifying any or all such patent rights.

This document supersedes EN 840-2:2004.

Technical changes since the latest edition:

- The content was adapted to the current state of the art and revised editorially.
- Figure 3 has been deleted.
- Frontal receivers Form B and C have been deleted. Figure 2 has been changed accordingly.

This European Standard is one part of the series of standards of EN 840 with the main title *Mobile waste and recycling containers* comprising the following parts:

- *Part 1: Containers with 2 wheels with a capacity up to 400 l for comb lifting devices — Dimensions and design;*
- *Part 2: Containers with 4 wheels with a capacity up to 1 300 l with flat lid(s), for trunnion and/or comb lifting devices — Dimensions and design* (the present document);
- *Part 3: Containers with 4 wheels with a capacity up to 1 300 l with dome lid(s), for trunnion and/or comb lifting devices — Dimensions and design;*
- *Part 4: Containers with 4 wheels with a capacity up to 1 700 l with flat lid(s), for wide trunnion or BG-and/or wide comb lifting devices — Dimensions and design;*
- *Part 5: Performance requirements and test methods;*
- *Part 6: Safety and health requirements.*

According to the CEN/CENELEC Internal Regulations, the national standards organisations of the following countries are bound to implement this European Standard: Austria, Belgium, Bulgaria, Croatia, Cyprus, Czech Republic, Denmark, Estonia, Finland, Former Yugoslav Republic of Macedonia, France, Germany, Greece, Hungary, Iceland, Ireland, Italy, Latvia, Lithuania, Luxembourg, Malta, Netherlands, Norway, Poland, Portugal, Romania, Slovakia, Slovenia, Spain, Sweden, Switzerland, Turkey and the United Kingdom.

1 Scope

This European Standard specifies dimensions and design requirements of mobile waste containers with 4 wheels, with flat lid(s) and capacity up to 1 300 l to be used by trunnion and/or comb lifting device.

2 Normative references

The following documents, in whole or in part, are normatively referenced in this document and are indispensable for its application. For dated references, only the edition cited applies. For undated references, the latest edition of the referenced document (including any amendments) applies.

EN 840-5, *Mobile waste and recycling containers — Part 5: Performance requirements and test methods*

EN 840-6:2012, *Mobile waste and recycling containers — Part 6: Safety and health requirements*

EN 1501-1, *Refuse collection vehicles — General requirements and safety requirements — Part 1: Rear loaded refuse collection vehicles*

EN 1501-5:2011, *Refuse collection vehicles — General requirements and safety requirements — Part 5: Lifting devices for refuse collection vehicles*

EN ISO 11469, *Plastics — Generic identification and marking of plastics products (ISO 11469)*

3 Terms and definitions

For the purposes of this document, the following terms and definitions apply.

NOTE Terms for components of mobile waste containers and lifting devices in three languages are given in Annex A of EN 840-1:2012.

3.1 mobile waste and recycling container

appropriately designed container fitted with wheels intended to temporarily store waste

3.2 lifting device

structure which picks-up, tilts and empties containers

3.3 comb lifting device

lifting device in which the picking-up system consists of a row of teeth and a locking system to retain the container during emptying

3.4 trunnion lifting device

lifting device in which the picking-up system consists of a pair of arms with automatic locking mechanism to fit the trunnion to retain the container during emptying

3.5 volume

total space inside the container when the lid is closed

Note 1 to entry: See Table 1.

3.6

nominal volume

capacity

volume stated by the manufacturer

Note 1 to entry: See Table 1 without tolerances.

Note 2 to entry: The English term "capacity" and the French term "capacité" are translated in the German version by the term "Nennvolumen".

3.7

nominal mass

mass, which is calculated as given in Clause 6

3.8

total permissible mass

mass of the container plus the nominal mass

3.9

functional and safety dimensions

essential dimensions which ensure the functionality and interchangeability of the container with the compatible lifting device and which are necessary for the operator's safety and health

4 Volumes

This part of EN 840 identifies the two classes of containers:

- Class I - small size (nominal volume up to 1 000 l);
- Class II - large size (nominal volume between 1 000 l and 1 300 l).

Within the two above-mentioned classes of containers the following volumes are identified: 500 l, 660 l, 770 l, 1 000 l, 1 100 l and 1 200 l. Nominal volumes different from those referenced can be used by agreement between user and manufacturer. The tolerance of the volumes shall be $\pm 5\%$ maximum measured according to EN 840-5.

5 Dimensions and design

5.1 The design of the containers need not correspond to the drawings given in Figure 1. The functional dimensions given in Table 1 shall be respected. Recommendations for manufacturers of lifting devices are given in Annex A (see also EN 1501-1).

5.2 The container shall be constructed so that when it is unloaded or loaded with a nominal load (see Clause 6), it fits on an approved compatible lifting device. It shall be automatically locked safely into the lifting device during the lifting operation. If the container is equipped with a comb receiver, it shall correspond to Figure 2.

5.3 The lid(s) shall cover the opening of the container completely. It shall be opened easily by itself during the emptying cycle it/they shall be made with at least two fixing points and have at least one means of opening.

5.4 Handles fitted in front of the trunnion shall have a measurement over the handles of 10 mm less than the actual measurement in Table 1, dimension N° 33. The handles and their location also shall be designed so that they do not damage the operator.

5.5 If the container has ribs in the frontal receiver they shall meet the requirements of Figures 2 and 4.

5.6 The container shall have four swivel castors. Each swivel castor shall be capable of withstanding 1/3 of the total permissible mass. Each castor shall meet the requirements of EN 840-5. The container shall have facilities for mounting the castor platine according to at least one of the measurements as shown in Figure 5.

5.7 All the surfaces of the container including design features shall be smooth and free of any foreign bodies or flaws.

5.8 The container should have a drain plug.

5.9 When direction locks are fitted they shall be fixed on at least two castors.

5.10 The container should be fitted with two braked wheels to requirements of EN 840-5. In case of centralised braking and locking system the brake pedal and the lock shall be fixed on a lateral side of the container. The centralised locking shall be able to be unlocked with a standard triangular key as shown in Figure 6. The effectiveness of the centralised braking system shall conform to EN 840-5.

6 Nominal mass

The container shall be constructed strongly enough to carry a mass of $0,4 \text{ kg/dm}^3 \times \text{nominal volume}$. Containers with a nominal volume of more than 1 100 l shall be constructed strongly enough to carry a load of 440 kg.

7 Safety and health requirements

The container shall meet the safety and health requirements according to EN 840-6.

8 Testing

The container shall fulfil the performance requirements and the tests of EN 840-5.

9 Marking

9.1 Each container complying with the requirements of this part of EN 840 shall be durably and readably marked on the body in a visible part with:

- number of this European Standard (EN 840-2);
- nominal volume;
- manufacturer's name or trademark;
- total permissible mass, in kilograms;
- year and month of manufacturing.

9.2 Additional marking for quality, recycling, etc. is allowed. Starting five years after the publication of this standard, plastic parts of containers, lids and wheels shall be marked in accordance with EN ISO 11469. The use of recycled materials is allowed, presuming that all requirements of this standard are complied with.

10 Designation

The container complying with the requirements of this European Standard shall be designated as follows:

	Container	EN 840-2	660	A	O	264
Description						
Standard number						
Nominal volume, in litres						
Frontal receiver form: A = frontal receiver 0 = without frontal receiver						
Lateral receiver: A = trunnions 0 = without lateral receiver						
Nominal load, in kilograms						

Table 1 — Dimensions

Dimensions in millimetres

Dimension N°	Class I - Small sizes < 1 000 l			Class II - Large sizes ≥ 1 000 l			Remarks
	500 l	660 l	770 l	1 000 l	1 100 l	1 200 l	
1 ^a	1 370 ± 10	1 370 ± 10	1 370 ± 10	1 370 ± 10	1 370 ± 10	1 370 ± 10	In case of trunnions
2	680 max.	780 max.	800 max.	1 115 max.	1 115 max.	1 115 max.	Total width lid(s) closed
3	740 max.	850 max.	870 max.	1 190 max.	1 190 max.	1 190 max.	When lid open
4	1 370 max.	1 370 max.	1 370 max.	1 470 max.	1 470 max.	1 470 max.	
5 ^a	860 min.; 1 290 max.	860 min.; 1 290 max.	860 min.; 1 290 max.	860 min.; 1 290 max.	860 min.; 1 290 max.	860 min.; 1 290 max.	Tipping edge
6	480 ± 50	585 ± 50	585 ± 50	870 ± 50	885 ± 50	885 ± 50	
7 ^a	135 min.; 280 max.	135 min.; 280 max.	135 min.; 280 max.	135 min.; 280 max.	135 min.; 280 max.	135 min.; 280 max.	In case of trunnions and min 850 from ground
8 ^a	700 to 850	700 to 850	700 to 850	700 to 850	700 to 850	700 to 850	Handle position if present
9	600 to 850	600 to 850	600 to 850	600 to 850	600 to 850	600 to 850	Lock position if present
10 ^a	460 ⁰ ₋₄₅	460 ⁺⁶⁵ ₋₄₅	460 ⁺⁶⁵ ₋₄₅	500 ⁺¹⁵ ₋₄₀	500 ⁺¹⁵ ₋₄₀	500 ⁺¹⁵ ₋₄₀	In case of trunnions
11 ^a	∅ 200 ± 2 *)	∅ 200 ± 2 *)	∅ 200 ± 2 *)	∅ 200 ± 2 *)	∅ 200 ± 2 *)	∅ 200 ± 2 *)	*) ∅ min 160 optional according to 5.3 of EN 840-6:2012
12 ^a	19 min.	19 min.	19 min.	19 min.	19 min.	19 min.	In case of frontal receiver
13 ^a	13 ⁺⁵ ₋₃	13 ⁺⁵ ₋₃	13 ⁺⁵ ₋₃	13 ⁺⁵ ₋₃	13 ⁺⁵ ₋₃	13 ⁺⁵ ₋₃	In case of frontal receiver
14 ^a	21 ⁺² ₋₂	21 ⁺² ₋₂	21 ⁺² ₋₂	21 ⁺² ₋₂	21 ⁺² ₋₂	21 ⁺² ₋₂	In case of frontal receiver
15	-	-	-	-	-	-	This dimension is used no longer.
16 ^a	26 ± 1	26 ± 1	26 ± 1	26 ± 1	26 ± 1	26 ± 1	In case of frontal receiver
17 ^a	58 max.	58 max.	58 max.	58 max.	58 max.	58 max.	In case of frontal receiver
18 ^a	20 min.	20 min.	20 min.	20 min.	20 min.	20 min.	In case of frontal receiver
19	130 max.	130 max.	130 max.	130 max.	130 max.	130 max.	When ribs are fitted
20	15 max.	15 max.	15 max.	15 max.	15 max.	15 max.	
21 ^a	33 ⁺⁸ ₋₁	33 ⁺⁸ ₋₁	33 ⁺⁸ ₋₁	33 ⁺⁸ ₋₁	33 ⁺⁸ ₋₁	33 ⁺⁸ ₋₁	In case of frontal receiver
23 ^a	∅ 40 ± 2	∅ 40 ± 2	∅ 40 ± 2	∅ 40 ± 2	∅ 40 ± 2	∅ 40 ± 2	In case of trunnions
24 ^a	670 ⁺³⁰ ₀	670 ⁺³⁰ ₀	670 ⁺³⁰ ₀	670 ⁺³⁰ ₀	670 ⁺³⁰ ₀	670 ⁺³⁰ ₀	The front of the container beneath the ribs of the lifting comb shall be smooth. No constructions shall protrude in this area.
25 ^a	350 ± 10	350 ± 10	350 ± 10	350 ± 10	350 ± 10	350 ± 10	Clearance for lifting device
26	380 ± 30	480 ± 30	480 ± 30	750 ⁺⁵⁰ ₋₄₀	750 ⁺⁵⁰ ₋₄₀	750 ⁺⁵⁰ ₋₄₀	
27	130 min.	130 min.	130 min.	130 min.	130 min.	130 min.	Ground clearance

Table 1 (continued)

Dimensions in millimetres

Dimension N°	Class I - Small sizes < 1 000 l			Class II - Large sizes ≥ 1 000 l			Remarks
	500 l	660 l	770 l	1 000 l	1 100 l	1 200 l	
28 ^a	1 275 max.	1 275 max.	1 275 max.	1 275 max.	1 275 max.	1 275 max.	Lid
29 ^a	1 185 min.	1 185 min.	1 185 min.	1 185 min.	1 185 min.	1 185 min.	Inside operating length of frontal receiver
30 ^a	1200 ⁺¹⁵ ₀	1200 ⁺¹⁵ ₀	1200 ⁺¹⁵ ₀	1200 ⁺¹⁵ ₀	1200 ⁺¹⁵ ₀	1200 ⁺¹⁵ ₀	Overall frontal receiver
31 ^a	1 265 max.	1 265 max.	1 265 max.	1 265 max.	1 265 max.	1 265 max.	Overall length of the top rim or handles
32	5 ⁺⁸ ₀	5 ⁺⁸ ₀	5 ⁺⁸ ₀	5 ⁺⁸ ₀	5 ⁺⁸ ₀	5 ⁺⁸ ₀	Optional
33 ^a	1260 ⁺²⁰ ₋₁₀	1260 ⁺²⁰ ₋₁₀	1260 ⁺²⁰ ₋₁₀	1260 ⁺²⁰ ₋₁₀	1260 ⁺²⁰ ₋₁₀	1260 ⁺²⁰ ₋₁₀	In case of trunnions around the centre lifting trunnion there shall be a radius of 150 mm. There shall not be any projection beyond the trunnion boss (see Figure 3).
34	880 ⁺⁷⁰ ₋₅₀	880 ⁺²⁰ ₋₅₀	880 ⁺²⁰ ₋₅₀	880 ⁺²⁰ ₋₅₀	880 ⁺²⁰ ₋₅₀	950 ± 120	
35	1090 ⁺⁸⁰ ₋₇₀	1 090 ± 70	1 090 ± 70	1 090 ± 70	1 090 ± 70	1 090 ± 70	The outer corner shall be designed according to dimension W2 of EN 1501-5:2011, Table Fig. A.3-1
36 ^a	150 ± 3	150 ± 3	150 ± 3	150 ± 3	150 ± 3	150 ± 3	When ribs are fitted stiffeners can be placed at intervals from each side of the center of the lifting bar, equally spaced at/or multiples of 150 mm.
37 ^a	7 max.	7 max.	7 max.	7 max.	7 max.	7 max.	When ribs are fitted
38 ^a	6 ⁺² _{-4,5}	6 ⁺² _{-4,5}	6 ⁺² _{-4,5}	6 ⁺² _{-4,5}	6 ⁺² _{-4,5}	6 ⁺² _{-4,5}	In case of frontal receiver
40 ^a	R 4 max.	R 4 max.	R 4 max.	R 4 max.	R 4 max.	R 4 max.	In case of frontal receiver
41	10 min.	10 min.	10 min.	10 min.	10 min.	10 min.	
42	∅ 16 max.	∅ 16 max.	∅ 16 max.	∅ 16 max.	∅ 16 max.	∅ 16 max.	
43	∅ 6,6 ^{+0,2} ₀	∅ 6,6 ^{+0,2} ₀	∅ 6,6 ^{+0,2} ₀	∅ 6,6 ^{+0,2} ₀	∅ 6,6 ^{+0,2} ₀	∅ 6,6 ^{+0,2} ₀	
44	8,3 ^{+0,1} ₀	8,3 ^{+0,1} ₀	8,3 ^{+0,1} ₀	8,3 ^{+0,1} ₀	8,3 ^{+0,1} ₀	8,3 ^{+0,1} ₀	
45	≈ 50	≈ 50	≈ 50	≈ 50	≈ 50	≈ 50	
46 ^a	360 max.	360 max.	360 max.	360 max.	360 max.	360 max.	If two or more part lids are fitted they shall enable the comb and trunnion lifting device to operate correctly.

^a Compulsory dimensions for functional and safety reasons. The other dimensions indicated are suggested recommended values.

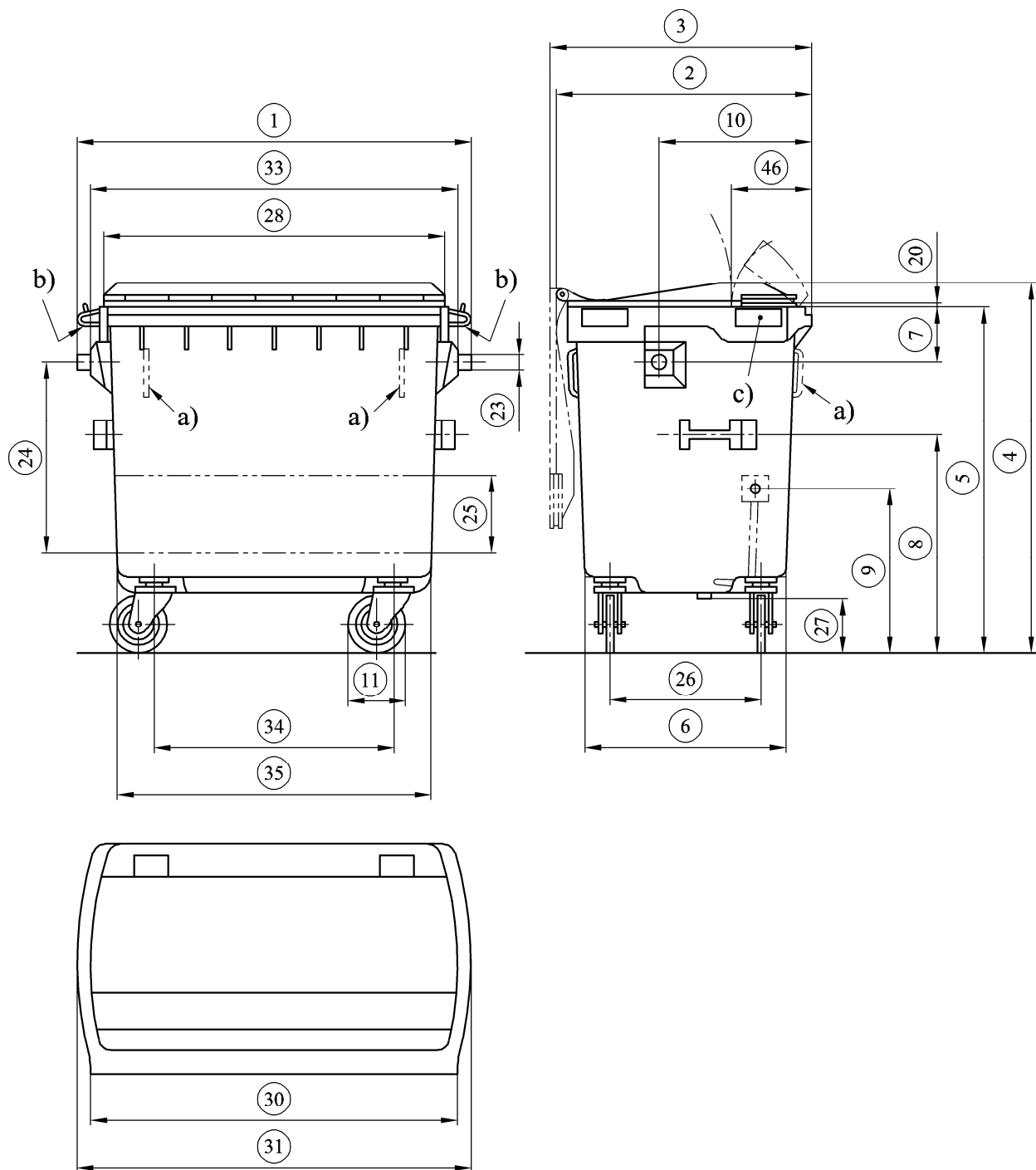

Key

- a) handles to be fitted if the container is without frontal receiver
- b) requirements for handle if it is above trunnion (see EN 840-6:2012, Figure 3)
- c) requirements for handle if in front of trunnion (see 5.4)

NOTE For more details regarding the dimensions, see Table 1.

Figure 1 — System dimensions

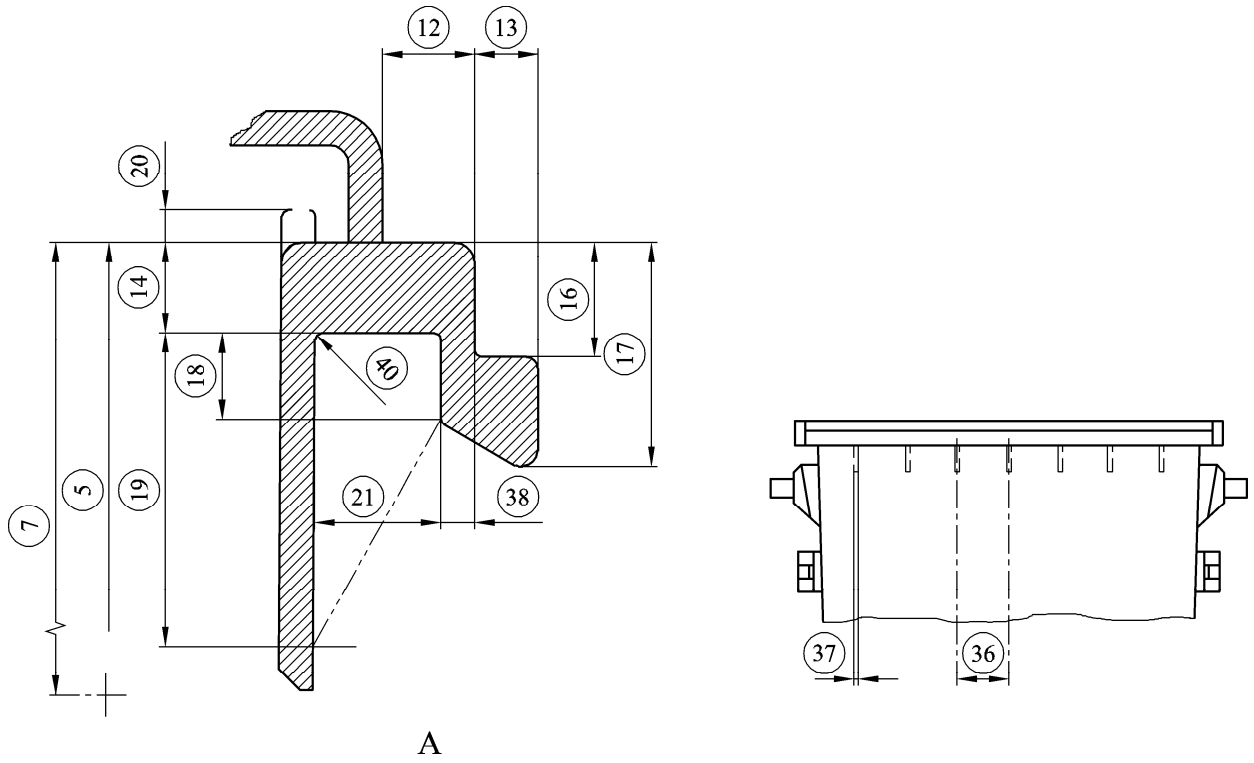

Key

A form A

NOTE For more details regarding the dimensions, see Table 1.

Figure 2 — Frontal receivers

Dimensions in millimetres

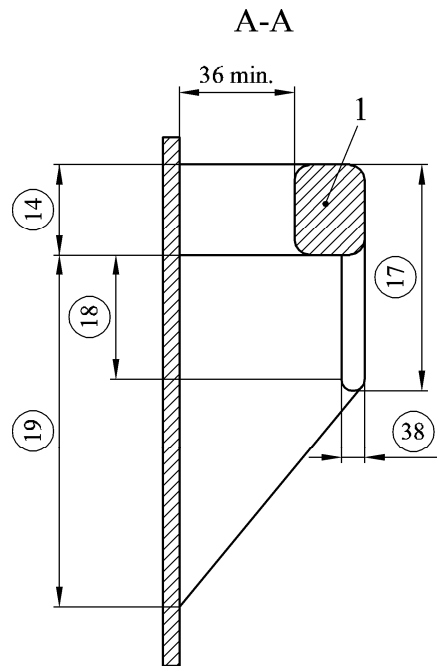

Key

1 handle

NOTE For more details regarding the dimensions, see Table 1.

Figure 3 — Handle

Dimensions in millimetres

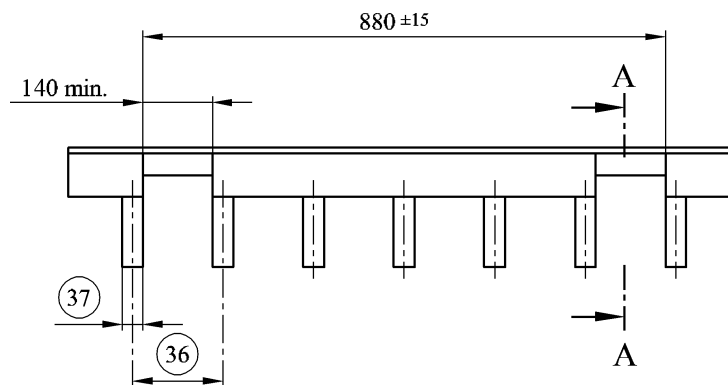

NOTE For more details regarding the dimensions, see Table 1.

Figure 4 — Frontal receiver with integrated handles

Dimensions in millimetres

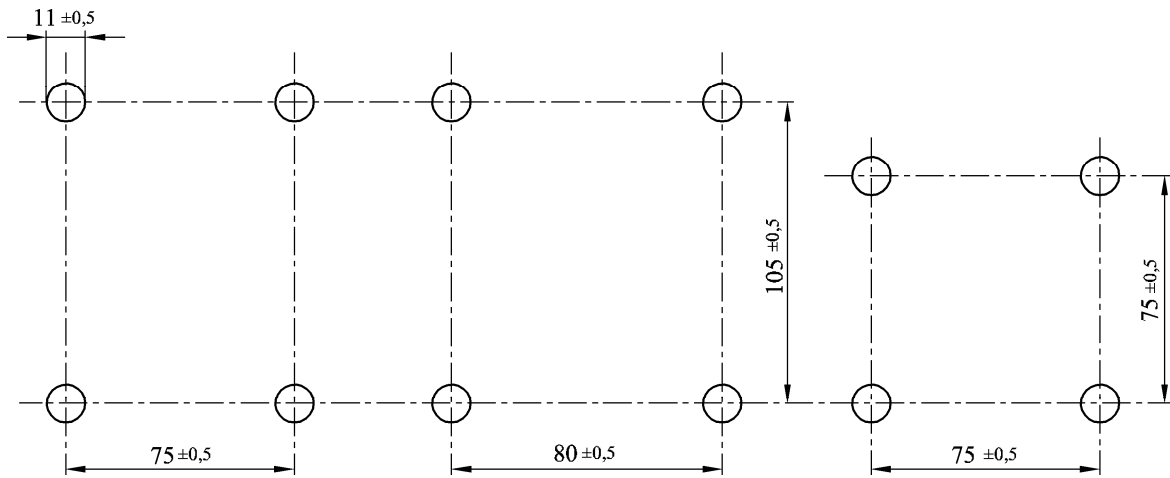

NOTE For more details regarding the dimensions, see Table 1.

Figure 5 — Distance between centres of castor wheels

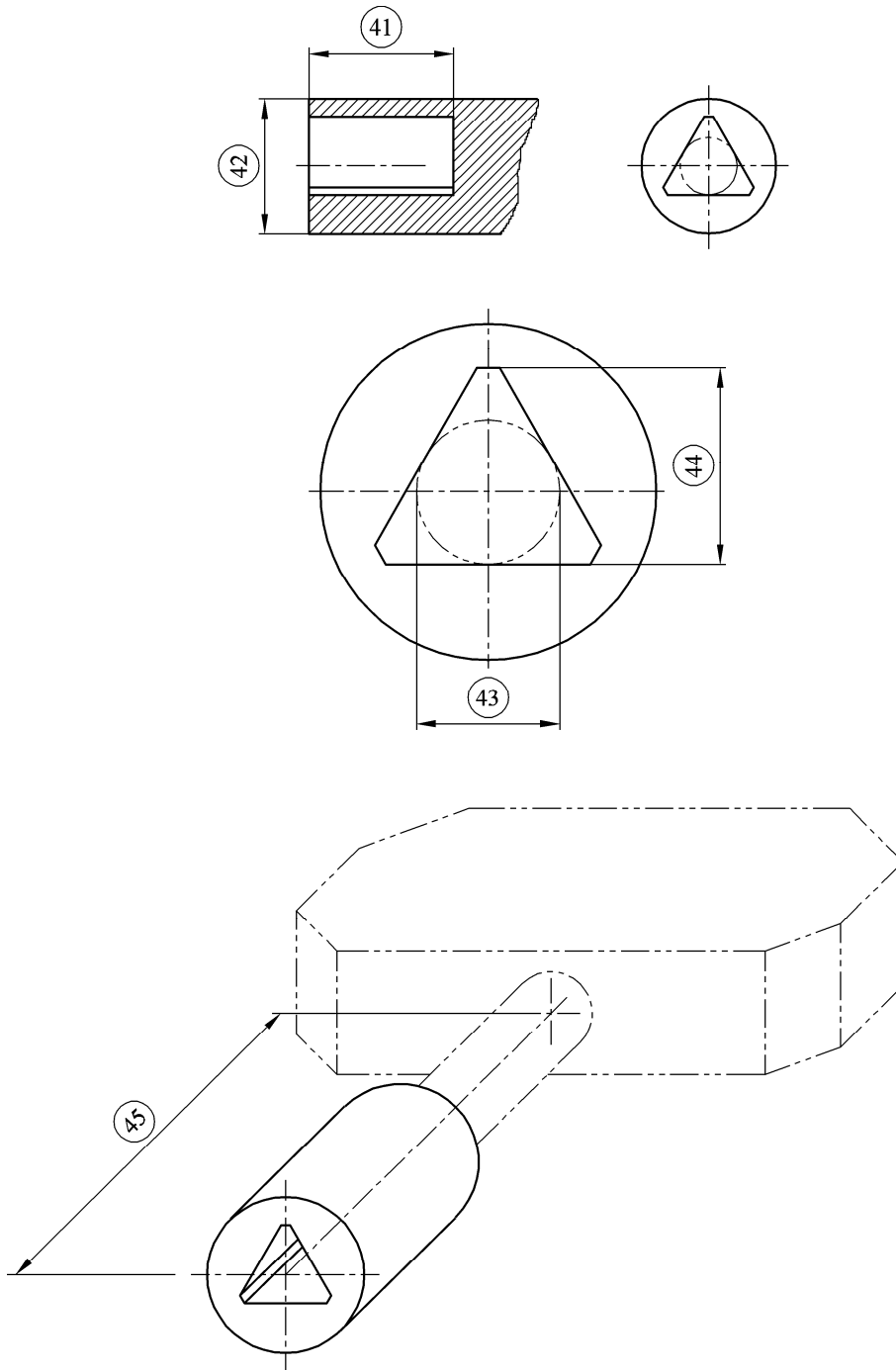

NOTE For more details regarding the dimensions, see Table 1.

Figure 6 — Standard triangular key

Annex A (informative)

Recommendations for manufacturers of lifting devices

Dimensions in millimetres

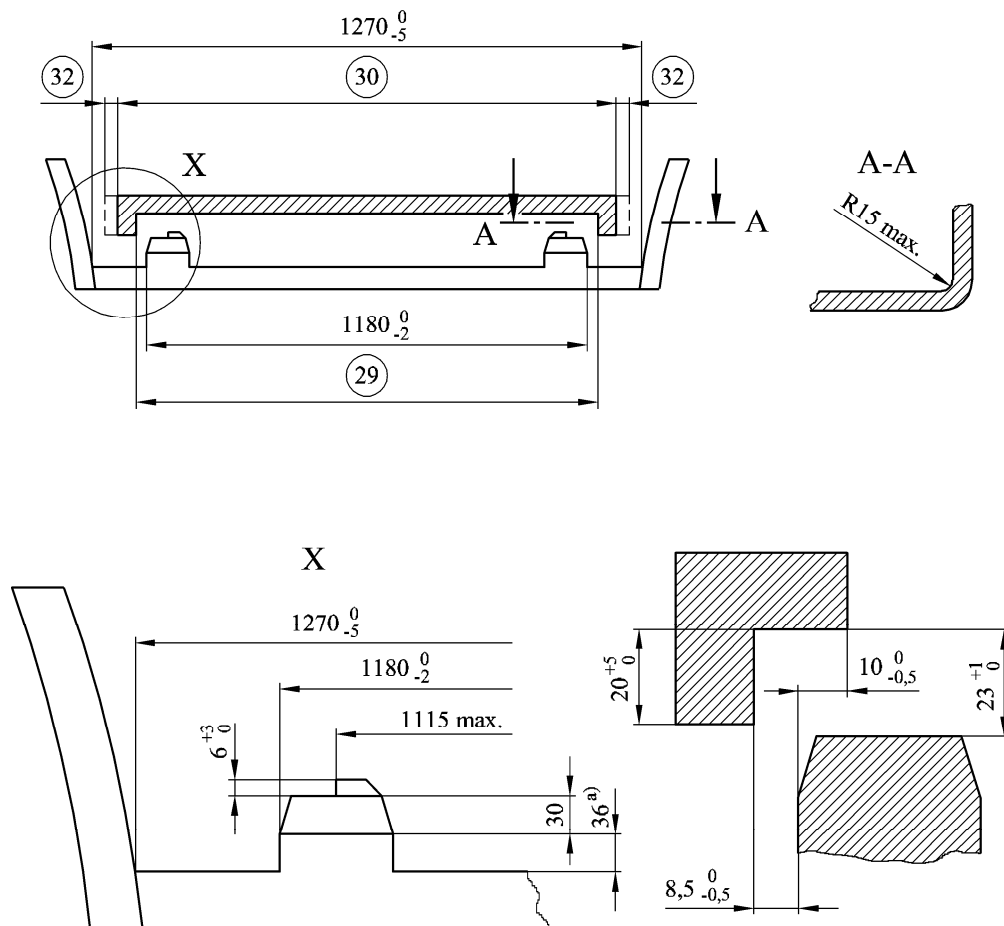

Key

a) nominal

NOTE For more details regarding the dimensions 29, 30 and 32, see Table 1.

Figure A.1 — Form D, general

For any single container not exceeding dimension N° 30 and any combination of containers (maintaining a minimum gap between them of 10 mm) which do not exceed a dimension of 1 200 mm.

Dimensions in millimetres

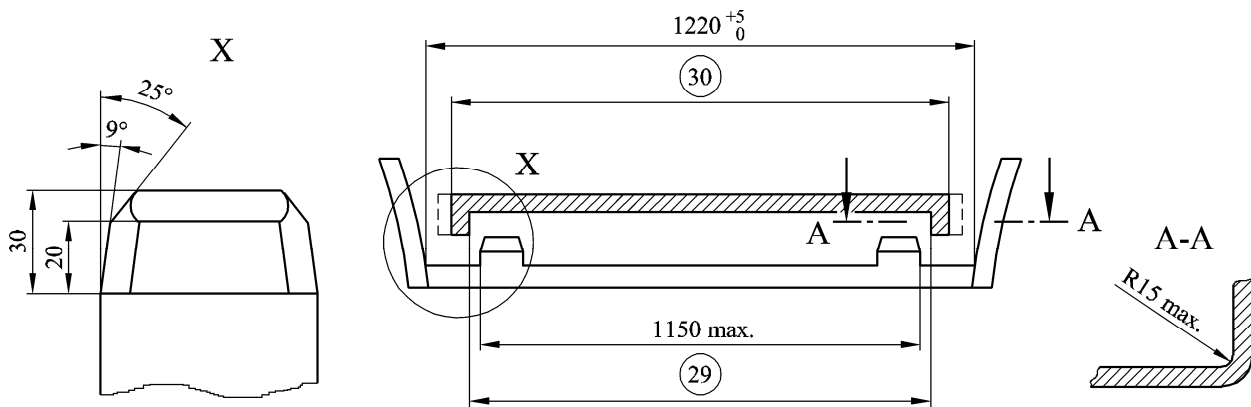

NOTE For more details regarding the dimensions 29 and 30, see Table 1.

Figure A.2 — Form E

Annex B (informative)

A-Deviations

A-Deviation: National deviation due to regulations, the alteration of which is for the time being outside the competence of the CEN-CENELEC-member.

This European Standard does not fall under any Directive of the EU. In the relevant CEN-CENELEC-countries these A-deviations are valid instead of the provisions of the European Standard until they have been removed.

DENMARK

EN 840-1 to EN 840-6 do not fulfil the national Danish legislation regarding requirements for health and safety. This legislation is based on *EEC-Directive 89/391/EC of 12 June 1989* and *EEC-Directive 90/269/EEC of 29 May 1990*.

The Danish legislation is written down in "Executive Order No. 867 of 13 October 1994 concerning Performance of Work" and in "Executive Order No. 1164 of 16 December 1994 concerning Manual Handling" both given by the Minister of Work. The Legal understanding of the Executive Orders are written in the Danish Working Environment Service (WES) guidelines. WES-guideline No. 4.1.0.1 of 1993 describes "Manual handling and transportation of domestic garbage" and No. 4.1.0.2 describes "Construction of technical systems and equipment for handling domestic garbage" (former WES circular-order No. 10/1990).

Therefore the manual handling and use of containers described in EN 840-1 to EN 840-6 can be met in Denmark with additional requirements.

Bibliography

- [1] EN 840-1:2012, *Mobile waste and recycling containers — Part 1: Containers with 2 wheels with a capacity up to 400 l for comb lifting devices — Dimensions and design*
- [2] EN 1501-2, *Refuse collection vehicles and associated lifting devices — General requirements and safety requirements — Part 2: Side loaded refuse collection vehicles*
- [3] EN 1501-3, *Refuse collection vehicles and their associated lifting devices — General requirements and safety requirements — Part 3: Front loaded refuse collection vehicles*
- [4] EN 14803, *Identification and/or determination of the quantity of waste*

British Standards Institution (BSI)

BSI is the national body responsible for preparing British Standards and other standards-related publications, information and services.

BSI is incorporated by Royal Charter. British Standards and other standardization products are published by BSI Standards Limited.

About us

We bring together business, industry, government, consumers, innovators and others to shape their combined experience and expertise into standards-based solutions.

The knowledge embodied in our standards has been carefully assembled in a dependable format and refined through our open consultation process. Organizations of all sizes and across all sectors choose standards to help them achieve their goals.

Information on standards

We can provide you with the knowledge that your organization needs to succeed. Find out more about British Standards by visiting our website at bsigroup.com/standards or contacting our Customer Services team or Knowledge Centre.

Buying standards

You can buy and download PDF versions of BSI publications, including British and adopted European and international standards, through our website at bsigroup.com/shop, where hard copies can also be purchased.

If you need international and foreign standards from other Standards Development Organizations, hard copies can be ordered from our Customer Services team.

Subscriptions

Our range of subscription services are designed to make using standards easier for you. For further information on our subscription products go to bsigroup.com/subscriptions.

With **British Standards Online (BSOL)** you'll have instant access to over 55,000 British and adopted European and international standards from your desktop. It's available 24/7 and is refreshed daily so you'll always be up to date.

You can keep in touch with standards developments and receive substantial discounts on the purchase price of standards, both in single copy and subscription format, by becoming a **BSI Subscribing Member**.

PLUS is an updating service exclusive to BSI Subscribing Members. You will automatically receive the latest hard copy of your standards when they're revised or replaced.

To find out more about becoming a BSI Subscribing Member and the benefits of membership, please visit bsigroup.com/shop.

With a **Multi-User Network Licence (MUNL)** you are able to host standards publications on your intranet. Licences can cover as few or as many users as you wish. With updates supplied as soon as they're available, you can be sure your documentation is current. For further information, email bsmusales@bsigroup.com.

BSI Group Headquarters

389 Chiswick High Road London W4 4AL UK

Revisions

Our British Standards and other publications are updated by amendment or revision.

We continually improve the quality of our products and services to benefit your business. If you find an inaccuracy or ambiguity within a British Standard or other BSI publication please inform the Knowledge Centre.

Copyright

All the data, software and documentation set out in all British Standards and other BSI publications are the property of and copyrighted by BSI, or some person or entity that owns copyright in the information used (such as the international standardization bodies) and has formally licensed such information to BSI for commercial publication and use. Except as permitted under the Copyright, Designs and Patents Act 1988 no extract may be reproduced, stored in a retrieval system or transmitted in any form or by any means – electronic, photocopying, recording or otherwise – without prior written permission from BSI. Details and advice can be obtained from the Copyright & Licensing Department.

Useful Contacts:

Customer Services

Tel: +44 845 086 9001

Email (orders): orders@bsigroup.com

Email (enquiries): cservices@bsigroup.com

Subscriptions

Tel: +44 845 086 9001

Email: subscriptions@bsigroup.com

Knowledge Centre

Tel: +44 20 8996 7004

Email: knowledgecentre@bsigroup.com

Copyright & Licensing

Tel: +44 20 8996 7070

Email: copyright@bsigroup.com



...making excellence a habit.™