

**Domestic gas-fired
forced convection
air heaters for space
heating not exceeding
a net heat input of 70
kW, without a fan to
assist transportation of
combustion air and/or
combustion products**

ICS 97.100.20

National foreword

This British Standard is the UK implementation of EN 778:2009. It supersedes BS EN 778:1998 which is withdrawn.

The UK participation in its preparation was entrusted to Technical Committee GSE/20, Non-domestic space heaters (gas).

A list of organizations represented on this committee can be obtained on request to its secretary.

This publication does not purport to include all the necessary provisions of a contract. Users are responsible for its correct application.

Compliance with a British Standard cannot confer immunity from legal obligations.

This British Standard was published under the authority of the Standards Policy and Strategy Committee on 30 November 2009.

© BSI 2009

ISBN 978 0 580 58603 3

Amendments/corrigenda issued since publication

Date	Comments

EUROPEAN STANDARD

EN 778

NORME EUROPÉENNE

EUROPÄISCHE NORM

October 2009

ICS 97.100.20

Supersedes EN 778:1998

English Version

Domestic gas-fired forced convection air heaters for space heating not exceeding a net heat input of 70 kW, without a fan to assist transportation of combustion air and/or combustion products

Générateurs d'air chaud à convection forcée utilisant les combustibles gazeux pour le chauffage de locaux à usage d'habitation de débit calorifique sur Hi inférieur ou égal à 70 kW, sans ventilateur pour aider l'alimentation en air comburant et/ou l'évacuation des produits de combustion

Gasbefeuerte Warmlufterzeuger mit erzwungener Konvektion zum Beheizen von Räumen für den häuslichen Gebrauch mit einer Nennwärmebelastung nicht über 70 kW, ohne Gebläse zur Beförderung der Verbrennungsluft und/oder der Abgase

This European Standard was approved by CEN on 12 September 2009.

CEN members are bound to comply with the CEN/CENELEC Internal Regulations which stipulate the conditions for giving this European Standard the status of a national standard without any alteration. Up-to-date lists and bibliographical references concerning such national standards may be obtained on application to the CEN Management Centre or to any CEN member.

This European Standard exists in three official versions (English, French, German). A version in any other language made by translation under the responsibility of a CEN member into its own language and notified to the CEN Management Centre has the same status as the official versions.

CEN members are the national standards bodies of Austria, Belgium, Bulgaria, Cyprus, Czech Republic, Denmark, Estonia, Finland, France, Germany, Greece, Hungary, Iceland, Ireland, Italy, Latvia, Lithuania, Luxembourg, Malta, Netherlands, Norway, Poland, Portugal, Romania, Slovakia, Slovenia, Spain, Sweden, Switzerland and United Kingdom.



EUROPEAN COMMITTEE FOR STANDARDIZATION
COMITÉ EUROPÉEN DE NORMALISATION
EUROPÄISCHES KOMITEE FÜR NORMUNG

Management Centre: Avenue Marnix 17, B-1000 Brussels

Contents

Page

Foreword.....	4
1 Scope	6
2 Normative references	7
3 Terms and definitions	8
3.1 Appliance and its constituent parts	8
3.2 Adjustment, control and safety devices	10
3.3 Operation of the appliance	13
3.4 Gases	15
3.5 Conditions of operation and measurement	16
3.6 Marking of the appliance and packaging	17
4 Classification	17
4.1 Classification of gases	17
4.2 Classification of appliance	18
5 Construction and design requirements	21
5.1 General	21
5.2 Adjusting, control and safety devices	27
5.3 Ignition devices	31
5.4 Flame supervision system	31
5.5 Start-gas flame establishment	32
5.6 Main flame establishment	33
5.7 Main burner	33
5.8 Facility for remote control	34
5.9 Thermostats and control of air temperature	34
5.10 Gas pressure test points	35
6 Operational requirements	35
6.1 Safety of operation	35
6.2 Efficiency	41
7 Test methods	42
7.1 General	42
7.2 Construction and design	49
7.3 Safety of operation	50
7.4 Efficiency	82
8 Marking and instructions	87
8.1 Marking of the appliance	87
8.2 Marking of the packaging	88
8.3 Utilization of symbols on the appliance and packaging	89
8.4 Instructions	91
9 Evaluation of POCEC conformity and their associated terminals	93
9.1 General	93
9.2 Type testing	93
9.3 Factory production control (FPC)	93
Annex A (informative) National situations	96
A.1 General	96
A.2 Categories listed in the body of the standard and marketed in different countries	96
A.3 Appliance supply pressures corresponding to the categories given in A.2	98
A.4 Special categories marketed nationally or locally	99
A.5 Test gases corresponding to the special categories given in A.4	105

A.6	Gas connections in the various countries	108
A.7	Flue connections in the various countries	110
Annex B	(informative) Equivalence rules¹	111
B.1	Conversion to categories within a restricted Wobbe index range	111
B.2	Conversion to categories within an identical Wobbe index range	111
B.3	Conversion to categories within a wider Wobbe index range	112
Annex C	(informative) A-deviations	113
C.1	General	113
C.2	Switzerland	113
Annex D	(normative) Special national conditions	114
D.1	Special national conditions	114
D.2	Belgium	114
D.3	Italy	114
D.4	Poland	114
Annex E	(informative) Identification of gas types in use in various countries	115
Annex F	(informative) National solutions for countries whose national bodies are Affiliate Members of CEN	116
F.1	Categories listed in the body of the standard and marketed in different countries	116
F.2	Appliance supply pressures corresponding to the categories given in F.1	116
F.3	Special categories marketed nationally or locally	116
F.4	Gases and test pressures corresponding to the special categories given in F.3	116
Annex G	(informative) Calculation of conversions of NO_x	117
Annex H	(informative) An example of sampling plans	118
H.1	Sampling plans	118
H.2	Inspection levels and procedures	119
Annex ZA	(informative)	120
Annex ZB	(normative) Clauses of this European Standard addressing the provisions of the EU Construction Products Directive	122
ZB.1	Scope and relevant characteristics	122
ZB.2	Procedure(s) for attestation of conformity of [construction products]	124
ZB.3	CE marking and labelling	126
	Bibliography	128

Foreword

This document (EN 778:2009) has been prepared by Technical Committee CEN/TC 180 “Domestic and non-domestic gas fired air heaters and non-domestic gas fired overhead radiant heaters”, the secretariat of which is held by AFNOR.

This European Standard shall be given the status of a national standard, either by publication of an identical text or by endorsement, at the latest by April 2010, and conflicting national standards shall be withdrawn at the latest by April 2010.

Attention is drawn to the possibility that some of the elements of this document may be the subject of patent rights. CEN [and/or CENELEC] shall not be held responsible for identifying any or all such patent rights.

This document supersedes EN 778:1998.

This document has been prepared under a mandate given to CEN by the European Commission and the European Free Trade Association, and supports essential requirements of EU Directive(s).

For relationship with EU Directive(s), see informative Annex ZA, and Annex ZB, which are integral parts of this document.

This revision modifies EN 778:1998. It has been prepared to incorporate requirements for combustion products evacuation ducts, POCEDs, supplied as an integral part of the system to support the EU Directive 89/106/EEC on construction products under mandate M 105. To this end, it extends the scope of the standard to cover type B₄ appliances.

Furthermore, the opportunity presented by this revision has been taken to update the standard in respect to EN 437:2003.

NOTE For countries requesting special categories (specified in EN 437:2003), the absence of specific information concerning A.3.3 and A.3.4 implies that the general requirements described in the body of the standard (see 4.1.1, 4.2.2, 4.2.3 and 4.2.5) also apply to these special categories.

- EN 525, *Non-domestic direct gas-fired forced convection air heaters for space heating not exceeding a net heat input of 300 kW*
- EN 621, *Non-domestic gas-fired forced convection air heaters for space heating not exceeding a net heat input of 300 kW, without a fan to assist transportation of combustion air and/or combustion products*
- EN 1020, *Non-domestic gas-fired forced convection air heaters for space heating not exceeding a net heat input of 300 kW, incorporating a fan to assist transportation of combustion air and/or combustion products*
- EN 1196, *Domestic and non-domestic gas-fired air heaters — Supplementary requirements for condensing air heaters*
- EN 1319, *Domestic gas-fired forced convection air heaters for space heating, with fan-assisted burners not exceeding a net heat input of 70 kW*
- EN 12669, *Direct gas-fired hot air blowers for use in greenhouses and supplementary non-domestic space heating*

According to the CEN/CENELEC Internal Regulations, the national standards organizations of the following countries are bound to implement this European Standard: Austria, Belgium, Bulgaria, Cyprus, Czech Republic, Denmark, Estonia, Finland, France, Germany, Greece, Hungary, Iceland, Ireland, Italy, Latvia, Lithuania, Luxembourg, Malta, Netherlands, Norway, Poland, Portugal, Romania, Slovakia, Slovenia, Spain, Sweden, Switzerland and the United Kingdom.

1 Scope

This European Standard specifies the requirements and test methods for the safety and efficiency of domestic gas-fired air heaters with (an) atmospheric burner(s) and without a fan to assist the transportation of combustion air and/or flue gases, hereafter referred to as "appliances".

This European Standard applies to Type B₁₁, B_{11AS}, B_{11BS}, B₄₁, B_{41AS}, B_{41BS}, C₁₁, C₂₁, C₃₁ and C₄₁ appliances with an input not exceeding 70 kW (net cv-basis), intended primarily for use in single unit residential dwellings. Provision of the heated air may be by means of ducting.

This European Standard does not apply to:

- a) appliances of the condensing type;
- b) appliances for outdoor installation;
- c) dual purpose air conditioning appliances (heating and cooling);
- d) appliances where the air is heated by an intermediate fluid;
- e) appliances with forced draught burners;
- f) appliances fitted with a manual or automatic means of adjusting the combustion air supply or the combustion products evacuation (including flue dampers);
- g) portable or transportable forced convection appliances;
- h) appliances having multiple heating units with a single draught diverter;
- i) appliances fitted with more than one flue outlet;
- j) C₂₁ and C₄₁ appliances for 3rd family gases;

NOTE For C₄₁ appliances, see all requirements and test methods that are valid for C₂₁ appliances, unless otherwise stated.

- k) appliances that are designed for continuous condensation within the flue system under normal operating conditions;
- l) appliances having Products Of Combustion Evacuation Ducts (POCED), that are non-metallic.

This European Standard is applicable to appliances which are intended to be type tested. It also includes requirements concerning the evaluation of conformity, including factory production control, but these requirements only apply to POCEDs and their associated terminals.

2 Normative references

The following referenced documents are indispensable for the application of this document. For dated references, only the edition cited applies. For undated references, the latest edition of the referenced document (including any amendments) applies.

EN 88-1:2007, *Pressure regulators and associated safety devices for gas appliances — Part 1: Pressure regulators for inlet pressures up to and including 500 mbar*

EN 125:1991, *Flame supervision devices for gas burning appliances — Thermo-electric flame supervision devices*

EN 126:2004, *Multifunctional controls for gas burning appliances*

EN 161:2007, *Automatic shut-off valves for gas burners and gas appliances*

EN 257:1992, *Mechanical thermostats for gas-burning appliances*

EN 298:2003, *Automatic gas burner control systems for gas burners and gas burning appliances with or without fans*

EN 437:2003, *Test gases — Test pressures — Appliance categories*

EN 1859:2000, *Chimneys — Metal Chimneys — Test methods*

EN 10226-1:2004, *Pipe threads where pressure tight joints are made on the threads — Part 1: Taper external threads and parallel internal threads — Dimensions, tolerances and designation*

EN 10226-2:2005, *Pipe threads where pressure tight joints are made on the threads — Part 2: Taper external threads and taper internal threads — Dimensions, tolerances and designation*

EN 60335-1:2002, *Household and similar electrical appliances — Safety — Part 1: General requirements (IEC 60335-1:2001, modified)*

EN 60335-2-102:2006, *Household and similar electrical appliances — Safety — Part 2-102: Particular requirements for gas, oil and solid-fuel burning appliances having electrical connections (IEC 60335-2-102:2004, modified)*

EN 60529:1992, *Degrees of protection provided by enclosures (IP code) (IEC 60529:1989)*

EN 60730-1:2000, *Automatic electrical controls for household and similar use — Part 1: General requirements (IEC 60730-1:1999, modified)*

EN 60730-2-1:1997, *Automatic electrical controls for household and similar use — Part 2-1: Particular requirements for electrical controls for electrical household appliances (IEC 60730-2-1:1989, modified)*

EN 60730-2-9:2002, *Automatic electrical controls for household and similar use — Part 2-9: Particular requirements for temperature sensing controls (IEC 60730-2-9:2000, modified)*

EN 61058-1:2002, *Switches for appliances — Part 1: General requirements (IEC 61058-1:2000 + A1:2001, modified)*

EN ISO 228-1:2003, *Pipe threads where pressure-tight joints are not made on the threads — Part 1: Dimensions, tolerances and designation (ISO 228-1:2000)*

EN ISO 3166-1:2006, *Codes for the representation of names of countries and their subdivisions Part 1: Country codes (ISO 3166-1:2006)*

EN ISO 6976:2005, *Natural gas — Calculation of the calorific value, density, relative density and Wobbe index from composition (ISO 6976:1995 including Corrigendum 1:1997, Corrigendum 2:1997 and Corrigendum 3:1999)*

ISO 1182:2002, *Reaction to fire tests for building products — Non-combustibility test*

ISO 7005-1:1992, *Metallic flanges — Part 1: Steel flanges*

ISO 7005-2:1988, *Metallic flanges — Part 2: Cast iron flanges*

ISO 7005-3:1988, *Metallic flanges — Part 3: Copper alloy and composite flanges*

CR 1404, *Determination of emissions from appliances burning gaseous fuels during type-testing*

3 Terms and definitions

3.1 Appliance and its constituent parts

3.1.1

domestic air heater

appliance designed for the heating by means of warm air and possibly ventilation of a single unit residential dwelling

3.1.2

forced convection air heater

appliance designed to provide space heating from a central source by distributing heated air, by means of an air moving device, either through ducting or directly into the heated space

3.1.3

gas inlet connection

part of the appliance intended to be connected to the gas supply

3.1.4

mechanical joint

mechanical means of obtaining soundness

means of ensuring the soundness of an assembly of several (generally metallic) parts without the use of liquids (e.g. pastes and tapes)

EXAMPLE metal to metal joints; conical joints; toroidal sealing rings (“O” rings); flat joints

3.1.5

gas circuit

part of the appliance that conveys or contains the gas between the appliance gas inlet connection and the burner(s)

3.1.6

restrictor

device with an orifice, which is placed in the gas circuit so as to create a pressure drop and thus reduce the gas pressure at the burner to a predetermined value for a given supply pressure and rate

3.1.7

gas rate adjuster

component allowing an authorized person to set the gas rate of the burner to a predetermined value according to the supply conditions

NOTE 1 Adjustment may be progressive (screw adjuster) or in discrete steps (by changing restrictors).

NOTE 2 The adjusting screw of an adjustable regulator is regarded as a gas rate adjuster.

NOTE 3 The action of adjusting this device is called "adjusting the gas rate".

NOTE 4 A factory sealed gas rate adjuster is considered to be non-existent.

3.1.8

setting an adjuster

immobilization of an adjuster (by some means such as e.g. a screw) after the manufacturer or installer has adjusted it setting an adjuster

3.1.9

sealing an adjuster

setting of an adjuster using a material such that any attempt to change the adjustment breaks the sealing material and makes the interference with the adjuster apparent;

the adjuster is then said to be "sealed" in its adjustment position

NOTE 1 A factory sealed adjuster is considered to be non-existent.

NOTE 2 A regulator is considered to be non-existent if it has been factory sealed in a position such that it is not operational in the range of supply pressures corresponding to the appliance category.

3.1.10

putting an adjuster or a control out of service

putting an adjuster or a control (e.g. of temperature, pressure) out of action and sealing it in this position

the appliance then functions as if the adjuster or control had been removed

3.1.11

injector

component that admits the gas into a burner

3.1.12

main burner

burner that is intended to assure the thermal function of the appliance

3.1.13

ignition device

any means (e.g. flame, electrical ignition device or other device) used to ignite the gas at the ignition burner or at the main burner

NOTE This device can operate intermittently or permanently.

3.1.14

ignition burner

burner whose flame is intended to ignite another burner

3.1.15

aeration adjuster

device enabling the air to be set at the desired value according to the supply conditions

NOTE The action of adjusting this device is called "adjusting the aeration".

3.1.16

combustion circuit

combustion circuit comprises the air supply circuit, the combustion chamber, the heat exchanger and the combustion products evacuation circuit so far as this is part of the appliance

3.1.17

combustion chamber

enclosure inside which combustion of the air-gas mixture takes place

3.1.18

flue outlet

part of an appliance that connects with a flue to evacuate the products of combustion

3.1.19

draught diverter

device placed in the combustion products circuit to reduce the influence of flue-pull and that of down-draught on the burner performance and combustion

3.1.20

flue terminal

device fitted at the end of the duct system which enables the discharge of flue gases and may, at the same time, allow entry of combustion air

3.1.21

POCED

combustion products evacuation duct that is intended to be used only with a specific appliance/system; this duct being either supplied with the appliance/system or specified in the manufacturers instructions

3.2 Adjustment, control and safety devices

3.2.1

range rating device

component on the appliance intended to be used by the installer to adjust the heat input of the appliance, within a range of heat inputs stated by the manufacturer, to suit the actual heat requirements of the installation

NOTE This adjustment may be progressive (e.g. by use of a screw adjuster) or in discrete steps (e.g. by changing restrictors).

3.2.2

automatic burner system

burner system in which, when starting from the completely shut-down condition, the start-gas flame is detected and proved and the main gas valve(s) is(are) actuated without manual intervention

3.2.3

automatic burner control system

system comprising at least a programming unit and all the elements of a flame detector device;

the various functions of an automatic burner control system may be in one or more housings [EN 298:2003]

3.2.4

non-automatic burner control system

burner system with an ignition burner which is ignited manually

3.2.5

programming unit

device which reacts to signals from control and safety devices, gives control commands, controls the start-up sequence, supervises the burner operation and causes controlled shut-down, and if necessary safety shut-down and lock-out;

the programming unit follows a predetermined sequence of actions and always operates in conjunction with a flame detector device [EN 298:2003]

3.2.6

Programme

sequence of control operations determined by the programming unit involving switching on, starting up, supervising and switching off the burner;

safety actions such as safety shut down and lock out are also part of the programme [EN 298:2003]

3.2.7

flame detector device

device by which the presence of a flame is detected and signalled;

it can consist of a flame sensor, an amplifier and a relay for signal transmission. These parts, with the possible exception of the actual flame sensor, may be assembled in a single housing for use in conjunction with a programming unit [EN 298:2003]

3.2.8

flame signal

signal given by the flame detector device, normally when the flame sensor senses a flame [EN 298:2003]

3.2.9

flame simulation

condition which occurs when the flame signal indicates the presence of a flame when in reality no flame is present [EN 298:2003]

3.2.10

pressure regulator¹⁾

device which maintains the outlet pressure constant independent of the variations in inlet pressure and/or flow rate within defined limits

3.2.11

adjustable pressure regulator

regulator provided with means for changing the outlet pressure setting

3.2.12

flame supervision device

device that, in response to a signal from the flame detector, keeps the gas supply open and shuts it off in the absence of the supervised flame

3.2.13

automatic shut-off valve

valve designed to open when energized and to close automatically when de-energized

1) The term "regulator" is used in this case and for a volume regulator.

3.2.14

room temperature control thermostat

device controlling the operation of the appliance (by on/off, high/low or modulating control) and enabling the room temperature to be kept automatically, within a given tolerance, at a predetermined value

3.2.15

overheat cut-off device

device that shuts off and locks out the gas supply before the appliance is damaged and/or before safety is put into question, and that requires manual intervention to restore the gas supply

3.2.16

temperature limiter

device which is intended to keep a temperature below one particular value during normal operation conditions and which may have a provision for setting by the user

3.2.17

overheat limit device

device which is intended to keep a temperature below one particular value during abnormal operation conditions and which has either no provision for setting or is provided with a maximum temperature limit stop

NOTE The overheat limit device may be of the automatic or the manual reset type.

3.2.18

fan control

control that starts and/or stops the air delivery fan when the temperature of the delivered air reaches certain predetermined values

3.2.19

temperature sensing element; temperature sensor

component that detects the temperature of the environment to be supervised or controlled

3.2.20

combustion product discharge safety system

system that automatically shuts off the gas supply to the main burner, and perhaps to the ignition burner, when spillage of combustion products from the draught diverter is detected

3.2.21

atmosphere sensing device

device designed to shut off the gas supply before the concentration of combustion products of the surrounding atmosphere reaches a set value

3.2.22

modulating control

automatic control by which the heat input of the appliance can be varied in a continuous manner between the nominal heat input and a minimum value

3.2.23

high/low control

automatic control which permits an appliance to operate either at the nominal heat input or at a fixed reduced heat input

3.2.24

closed position indicator switch

switch fitted to an automatic shut-off valve which indicates when the closure member is in the closed position

3.2.25

proof of closure switch

switch fitted to an automatic shut-off valve with mechanical overtravel which indicates when the closure member is in the closed position

3.2.26

valve proving system

system to check the effective closure of automatic shut-off valves

3.3 Operation of the appliance

3.3.1

volume flow rate

V

volume of gas consumed by the appliance in unit time during continuous operation

NOTE The volume flow rate is expressed in cubic metres per h (m^3/h), litres per min (l/min), cubic decimetres per h (dm^3/h) or cubic decimetres per second (dm^3/s). [EN 437:2003]

3.3.2

mass flow rate

M

mass of gas consumed by the appliance in unit time during continuous operation

NOTE The mass flow rate is expressed in kilograms per hour (kg/h) or grams per hour (g/h). [EN 437:2003]

3.3.3

heat input

Q

quantity of energy used in unit time corresponding to the volumetric or mass flow rates: the calorific value used being the net or gross calorific value

NOTE The heat input is expressed in kilowatts (kW). [EN 437:2003]

3.3.4

nominal heat input

Q_n

value of the heat input (kW) declared by the manufacturer

3.3.5

flame stability

characteristic of flames which remain on the burner ports or in the flame reception zone intended by the construction

3.3.6

flame lift

total or partial lifting of the base of the flame away from the burner port or the flame reception zone provided by the design

NOTE Flame lift may cause the flame to blow out (i.e. extinction of the air-gas mixture).

3.3.7

light-back

entry of a flame into the body of the burner

3.3.8

light-back at the injector

ignition of the gas at the injector, either as a result of light-back into the burner or by the propagation of a flame outside the burner

3.3.9

sooting

phenomenon appearing during incomplete combustion and characterized by deposits of soot on the surfaces or parts in contact with the combustion products or with the flame

3.3.10

yellow tipping

yellowing of the tip of the blue cone of an aerated flame

3.3.11

first safety time

interval between the ignition burner gas valve, the start gas valve or main gas valve, as applicable, being energized and the ignition burner gas valve, start gas valve or main gas valve, as applicable, being de-energized if the flame detector signals the absence of a flame at the end of this interval

NOTE Where there is no second safety time, this is called the safety time.

3.3.12

second safety time

where there is a first safety time to either a ignition burner or start gas flame only, the interval between the main gas valve being energized and the main gas valve being de-energized if the flame detector signals the absence of a flame

3.3.13

waiting time

time between safety shut-down any (re)start attempt

3.3.14

start gas

gas that is supplied at the start gas rate to establish the start gas flame

3.3.15

start gas rate

restricted gas flow rate admitted either to a separate ignition burner or to the main burner during the first safety time

3.3.16

start gas flame

flame established at the start gas rate either at the main burner or at a separate ignition burner

3.3.17

running condition of the system

running condition in which the burner is in normal operation under the supervision of the programming unit and its flame detector device

3.3.18

controlled shut-down

process by which the power to the gas shut-off valve(s) is removed immediately, e.g. as a result of the action of a controlling function [EN 298:2003]

3.3.19

safety shut-down

process which is effected immediately following the response of a protection device or a fault in the automatic burner control system and puts the burner out of operation;

the resulting state of the system is defined by deactivated terminals for the gas shut-off valves and the ignition device [EN 298:2003]

3.3.20 Lock-out

3.3.20.1

non-volatile lock-out

safety shut-down condition of the system, such that a restart can only be accomplished by a manual reset of the system and by no other means [EN 298:2003]

3.3.20.2

volatile lock-out

safety shut-down condition of the system, such that a restart can only be accomplished by either the manual reset of the system or an interruption of the electrical supply and its subsequent restoration [EN 298:2003]

3.3.21

spark restoration

process by which, after disappearance of the flame signal, the ignition device is energized again without the gas supply having been totally interrupted;

this process ends with the restoration of the running condition or, if there is no flame signal at the end of the safety time, with non-volatile lock-out

3.3.22

automatic recycling

process by which, following loss of flame signal during the running condition or accidental interruption of the operation of the appliance, the gas supply is interrupted and the complete start sequence is automatically re-initiated. This process ends with the restoration of the running condition or, if there is no flame signal at the end of the safety time, or, if the cause of the accidental interruption has not disappeared, with volatile lock-out or non-volatile lock-out

3.3.23

ignition opening time

time interval between ignition of the supervised flame and the moment when the valve is held open

3.3.24

extinction safety time

time interval between extinction of the supervised flame and the gas supply being shut off to the main burner and/or to the ignition burner

3.4 Gases

3.4.1

test gases

gases intended for the verification of the operational characteristics of appliances using combustible gases; they comprise the reference and the limit gases [EN 437:2003]

3.4.2

reference gases

test gases with which appliances operate under nominal conditions when they are supplied at the corresponding normal pressure [EN 437:2003]

3.4.3

limit gases

test gases representative of the extreme variations in the characteristics of the gases for which appliances have been designed [EN 437:2003]

3.4.4

gas pressure

static pressure, relative to the atmospheric pressure, measured at right angles to the direction of flow of the gas

NOTE Test pressures are expressed in millibars (mbar) or bars.

3.4.5

test pressure

gas pressures used to verify the operational characteristics of appliances using combustible gases. They consist of normal and limit pressures

NOTE Test pressures are expressed in millibars (mbar) - 1 mbar = 10^2 Pa [EN 437:2003]

3.4.6 normal pressure

p_n
pressure under which the appliance operates in nominal conditions when supplied with the corresponding reference gas [EN 437:2003]

3.4.7 limit pressure (maximum limit pressure p_{max} and minimum limit pressure p_{min})

pressures representative of the extreme variations in the appliance supply conditions [EN 437:2003]

3.4.8 pressure couple combination of two distinct gas distribution pressures applied by reason of the significant difference existing between the Wobbe indices within a single family or group in which:

- the higher pressure corresponds only to gases of low Wobbe index;
- the lower pressure corresponds to gases of high Wobbe index [EN 437:2003]

3.4.9 relative density

d
ratio of the masses of equal volumes of dry gas and dry air under the same conditions of temperature and pressure

3.4.10 calorific value quantity of heat produced by the complete combustion, at a constant pressure equal to 1 013,25 mbar, of a unit volume or mass of gas, the constituents of the combustible mixture being taken at reference conditions and the products of combustion being brought back to the same conditions

A distinction is made between:

- the gross calorific value H_s in which the water produced by combustion is assumed to be condensed;
- the net calorific value H_i in which the water produced by combustion is assumed to be in the vapour state

NOTE The calorific value is expressed either in megajoules per cubic metre of dry gas at the reference conditions (MJ/m^3) or in megajoules per kilogram of dry gas (MJ/kg) [EN 437:2003]

3.4.11 Wobbe index gross Wobbe index: W_s ; net Wobbe index: W_i

ratio of the calorific value of a gas per unit volume and the square root of its relative density under the same reference conditions. The Wobbe index is said to be gross or net according to whether the calorific value used is the gross or net calorific value

NOTE The Wobbe index is expressed either in megajoules per cubic metre of dry gas at the reference conditions (MJ/m^3) or in megajoules per kilogram of dry gas (MJ/kg) [EN 437:2003]

3.5 Conditions of operation and measurement

3.5.1 reference conditions:

- for calorific values, temperature: 15 °C;
- for gas and air volumes dry, brought to 15 °C and to an absolute pressure of 1 013,25 mbar

3.5.2

cold condition

condition of the appliance required for some tests and obtained by allowing the unlit appliance to attain thermal equilibrium at room temperature

3.5.3

hot condition

condition of the appliance required for some tests and obtained by heating to thermal equilibrium at the nominal heat input specified by the manufacturer, any thermostat remaining fully open

3.5.4

thermal equilibrium

operating state of the appliance corresponding to a particular setting of the input, in which the measured value of the flue gas temperature remains steady within a tolerance of $\pm 2\%$ (°C reading) over a period of 10 min

3.6 Marking of the appliance and packaging

3.6.1

direct country of destination

country for which the appliance has been certified and which is specified by the manufacturer as the intended country of destination;

at the time of putting the appliance on the market and/or of installation, the appliance shall be capable of operating, without adjustment or modification, with one of the gases distributed in the country concerned, at the appropriate supply pressure

NOTE More than one country can be specified if the appliance, in its current state of adjustment, can be used in each of these countries.

3.6.2

indirect country of destination

country for which the appliance has been certified, but for which, in its present state of adjustment, it is not suitable;

subsequent modification or adjustment is essential in order that it can be utilized safely and correctly in this country

4 Classification

4.1 Classification of gases

Gases are classified into three families, possibly divided into groups according to the value of the Wobbe index. Table 1 specifies the families and groups of gas used in this standard.

Table 1 — Gas classification

Gas family	Gas group	Gross Wobbe index at 15 °C and 1 013,25 mbar MJ/m ³	
		Minimum	Maximum
First	a	22,4	24,8
Second		39,1	54,7
	H	45,7	54,7
	L	39,1	44,8
	E	40,9	54,7
Third		72,9	87,3
	B/P	72,9	87,3
	P	72,9	76,8
	B	81,8	87,3

4.2 Classification of appliance

4.2.1 General

Appliances can be classified according to:

- a) the gases they use;
- b) the mode of evacuation of combustion products.

4.2.2 Classification according to the gases capable of being used

4.2.2.1 Category I

Appliances of Category I are designed exclusively for the use of gases of a single family or of a single group:

- a) appliances designed for use on first family gases only:

Category I_{1a}: Appliances using only gases of Group a of the first family at the prescribed supply pressure (this category is not used).

- b) appliances designed for use on second family gases only:

Category I_{2H}: Appliances using only gases of Group H of the second family at the prescribed supply pressures.

Category I_{2L}: Appliances using only gases of Group L of the second family at the prescribed supply pressures.

Category I_{2E}: Appliances using only gases of Group E of the second family at the prescribed supply pressures.

Category I_{2E+}: Appliances using only gases of Group E of the second family, and operating with a pressure couple without adjustment on the appliance. The appliance gas regulator, if it exists, is not operative in the range of the two normal pressures of the pressure couple.

- c) appliances designed for use on 3rd family gases only:

Category I_{3B/P}: Appliances capable of using the third family gases (propane and butane) at the prescribed supply pressure.

Category I₃₊: Appliances capable of using the third family (propane and butane) and operating with a pressure couple without adjustment of the appliance other than a possible adjustment of the

primary air in order to change from butane to propane and vice versa. No operational pressure regulating device is permitted on the appliance.

Category I_{3P}: Appliances using only gases of Group P of the third family (propane) at the prescribed supply pressure.

4.2.2.2 Category II

Appliances of Category II are designed for use on gases of two families:

- a) appliances designed for use on gases of the first and second families:

Category II_{1a2H}: Appliances capable of using gases of Group a of the first family and gases of Group H of the second family. The first family gases are used under the same conditions as for Category I_{1a}. The second family gases are used under the same conditions as for Category I_{2H}.

- b) appliances designed for use on gases of the second and third families:

Category II_{2H3B/P}: Appliances capable of using gases of Group H of the second family and gases of the third family. The second family gases are used under the same conditions as for Category I_{2H}. The third family gases are used under the same conditions as for Category I_{3B/P}.

Category II_{2H3+}: Appliances capable of using gases of Group H of the second family and gases of the third family. The second family gases are used under the same conditions as for Category I_{2H}. The third family gases are used under the same conditions as for Category I₃₊.

Category II_{2H3P}: Appliances capable of using gases of Group H of the second family and gases of Group P of the third family. The second family gases are used under the same conditions as for Category I_{2H}. The third family gases are used under the same conditions as for Category I_{3P}.

Category II_{2L3B/P}: Appliances capable of using gases of Group L of the second family and gases of the third family. The second family gases are used under the same conditions as for Category I_{2L}. The third family gases are used under the same conditions as for Category I_{3B/P}.

Category II_{2L3P}: Appliances capable of using gases of Group L of the second family and gases of Group P of the third family. The second family gases are used under the same conditions as for Category I_{2L}. The third family gases are used under the same conditions as for Category I_{3P}.

Category II_{2E3B/P}: Appliances capable of using gases of Group E of the second family and gases of the third family. The second family gases are used under the same conditions as for Category I_{2E}. The third family gases are used under the same conditions as for Category I_{3B/P}.

Category II_{2E+3+}: Appliances capable of using gases of Group E of the second family and gases of the third family. The second family gases are used under the same conditions as for Category I_{2E+}. The third family gases are used under the same conditions as for Category I₃₊.

Category II_{2E+3P}: Appliances capable of using gases of Group E of the second family and gases of Group P of the third family. The second family gases are used under the same conditions as for Category I_{2E+}. The third family gases are used under the same conditions as for Category I_{3P}.

4.2.2.3 Category III

Category III appliances are designed for use on the three families.

This category is not in general use.

Category III appliances admitted in certain countries are given in A.3.

4.2.3 Classification according to the mode of evacuation of the combustion products

4.2.3.1 General

Appliances are classified into several types according to the method of evacuation of the combustion products and admission of the combustion air.

4.2.3.2 Type B

An appliance intended to be connected to a flue which evacuates the products of combustion to the outside of the room containing the appliance.

The combustion air is drawn directly from the room.

Type B₁ Type B appliance incorporating a draught diverter;

Type B₁₁ natural draught Type B₁ appliance;

Type B_{11AS} Type B₁₁ appliance with an atmosphere sensing device;

Type B_{11BS} Type B₁₁ appliance with a combustion products discharge safety system;

Type B₄ Type B appliance, incorporating a draught diverter that is designed for connection via its flue duct to its flue terminal;

Type B₄₁ natural draught Type B₄ appliance;

Type B_{41AS} Type B₄₁ appliance with an atmosphere sensing device;

Type B_{41BS} Type B₄₁ appliance with a combustion products discharge safety system.

4.2.3.3 Type C

An appliance in which the combustion circuit (air supply, combustion chamber, heat exchanger, evacuation of the combustion products) is sealed with respect to the room in which the appliance is installed.

Type C₁ Type C appliance designed for connection via its ducts to a horizontal terminal, which at the same time admits fresh air to the burner and discharges the products of combustion to the outside through orifices that are either concentric or close enough to come under similar wind conditions;

Type C₁₁ natural draught Type C₁ appliance;

Type C₂ Type C appliance connected via its two ducts to a common duct system serving more than one appliance. This system consists of a single duct which supplies the combustion air and evacuates the combustion products;

Type C₂₁ natural draught Type C₂ appliance;

Type C₃ Type C appliance designed for connection via its ducts to a vertical terminal which at the same time admits fresh air to the burner and discharges the products of combustion to the outside through orifices which are either concentric or close enough to come under similar wind conditions;

Type C₃₁ natural draught Type C₃ appliance;

Type C₄ Type C appliance connected via its two ducts to a common duct system serving more than one appliance. This system consists of two ducts, one of which supplies the combustion air and the other which evacuates the products of combustion;

Type C₄₁ natural draught Type C₄ appliance.

5 Construction and design requirements

5.1 General

5.1.1 Conversion to different gases

The only acceptable operations when converting from a gas of one group or family to a gas of another group or family and/or to adapt to different gas distribution pressures are given below for each category.

NOTE It is recommended that these operations should be possible without disconnecting the appliance.

5.1.1.1 Category I

Category I_{2H}, I_{2L}, I_{2E}, I_{2E+}: no modification to the appliance.

Category I_{3B/P}: no modification to the appliance.

Category I₃₊: replacement of injectors or calibrated orifices but only in order to convert from one pressure couple to another (for example 28-30/37 mbar to 50/67 mbar or vice versa). In addition, it is permissible to adjust the primary air in order to change from butane to propane and vice versa.

Category I_{3P}: no modification to appliance relative to a change of gas. For a change of pressure, replacement of injectors and adjustment of gas rates.

5.1.1.2 Category II

5.1.1.2.1 Categories of appliance designed for use with gases of the first and second families

- a) adjustment of the gas rate with, if necessary, a change of injector, restrictors or regulator;
- b) adjustment of the gas rate of ignition burners, either by using an adjuster or by a change of injectors or restrictors and, if necessary, a change of complete ignition burners or of some of their parts;
- c) putting the regulator out of service under the conditions of 5.2.5;
- d) putting the gas rate adjusters out of service under the conditions of 5.2.2.2.

The adjustments or component changes are only acceptable when converting from a gas of the 1st family to a gas of the 2nd family or vice versa.

5.1.1.2.2 Categories of appliance designed for use with gases of the second and third families

- a) adjustment of the gas rate with, if necessary, a change of injector, restrictors or regulator;
- b) adjustment of the gas rate of ignition burners, either by using an adjuster or by a change of injectors or restrictors and, if necessary, a change of complete ignition burners or of some of their parts;
- c) putting the regulator out of service under the conditions of 5.2.5;
- d) putting the gas rate adjusters out of service under the conditions of 5.2.2.2.

These adjustments or component changes are only acceptable when:

- e) converting from a gas of the 2nd family to a gas of the 3rd family or vice versa;
- f) converting from one butane/propane pressure couple to another (e.g. 28-30/37 mbar to 50/67 mbar or vice versa).

5.1.1.3 Category III

Category III appliances admitted in certain countries are given in A.3.3 and A.3.4.

5.1.2 Materials and method of construction

The quality and thickness of materials used in the construction of the appliance and the method of assembling the various parts, shall be such that the constructional and performance characteristics do not alter significantly during a reasonable life under normal conditions of installation and use.

When the appliance is installed in accordance with the manufacturer's instructions, all components, including its POCED in the case of Type B₄, C₁, C₂, C₃ and C₄ appliances, shall withstand the mechanical, chemical and thermal conditions to which they may be subjected in the course of normal use.

In addition, the appliance shall be designed in such a way that there is no condensation at the operating temperature provided by the controls.

If condensation occurs at start-up, this shall not affect the operational safety. With the exception of the outlet of the flue system, any condensate formed shall not drop outside the appliance.

Copper shall not be used for gas carrying parts where its temperature is likely to exceed 100 °C.

Asbestos or materials containing asbestos shall not be used.

Hard solder containing cadmium in its formulation shall not be used. Solder that has a melting point below 450 °C after application shall not be used for gas carrying parts.

Materials downstream of the heat exchanger shall be corrosion-resistant or be effectively protected against corrosion. Zinc-coated steel materials are not allowed if they come into contact with combustion products during normal operation.

Where appropriate, materials used on the appliance shall be non-combustible in accordance with the requirements of ISO 1182:2002.

5.1.3 Accessibility for maintenance and use

Parts that are intended to be removable for maintenance or cleaning shall be readily accessible, shall be readily capable of correct assembly and difficult to assemble incorrectly. Such parts shall be impossible to assemble incorrectly where incorrect assembly would create a hazardous condition or result in damage to the appliance and its controls.

It shall be possible to clean the combustion chamber and the parts in contact with combustion products in accordance with the manufacturer's instructions without using special tools unless these are supplied as necessary accessories with the appliance.

Access shall be possible to all handles, buttons etc. required during normal use of the appliance, without having to remove any part of the case. For this purpose, the opening of a door or access panel is permitted.

Constructional parts accessible during use and maintenance shall be free from sharp edges and corners that might cause damage or personal injury during use or maintenance.

Panels that are required to be removed for normal servicing, maintenance and cleaning, shall be fitted with means of retention, where the appliance is intended to be installed more than 1,8 m above floor level,

measured from the underside of the appliance. This requirement shall be deemed to be satisfied if suitable hinges are fitted.

5.1.4 Thermal insulation

Any thermal insulation shall retain its insulating properties under the influence of heat and ageing. The thermal insulation shall withstand the thermal and mechanical stresses normally expected during boiler operation. The insulation shall be non-combustible, securely located and shall be protected against mechanical damage and condensate.

5.1.5 Gas connection

The gas connection to the appliance shall be accessible.

The clearance around the gas connection, after removing the appliance case if necessary, shall be adequate to allow the use of tools required to make the connection. It shall be possible to make all the connections without the use of special tools.

It shall be possible to connect the appliance by rigid metallic means to the gas supply.

If the appliance has a threaded connection, this thread shall comply with EN ISO 228-1:2003, EN 10226-1:2004 or EN 10226-2:2005. In the first case (EN ISO 228-1:2003), the end of the appliance inlet connection shall be sufficiently flat to allow the use of a sealing washer.

If flanges are used, they shall comply with ISO 7005-1:1992, ISO 7005-2:1988 or ISO 7005-3:1988, as appropriate, and the manufacturer shall provide the counterflanges and sealing gaskets.

The conditions of connections prevailing in the various countries are given in A.6.

5.1.6 Soundness

5.1.6.1 Soundness of the gas circuit

Holes (e.g. for screws and studs) intended for the assembly of parts shall not open into gasways. The wall thickness between drillings and gasways shall be at least 1 mm. This does not apply to orifices for measurement purposes.

The soundness of parts and assemblies making up the gas circuit and likely to be dismantled for routine maintenance in situ shall be achieved by means of mechanical joints (e.g. metal-to-metal joints, gasket, or O-ring joints) without the use of sealing materials (e.g. tape, paste or liquid). However, the sealing materials (e.g. tape, paste or liquid) may be used for permanent assemblies. Sealing materials shall remain effective under normal conditions of appliance use.

5.1.6.2 Soundness of the combustion circuit

Any means used to achieve soundness of the combustion circuit shall be such that it does not deteriorate under normal conditions of use and maintenance.

In particular, the soundness of parts likely to be removed in the course of routine maintenance shall be achieved by mechanical means.

5.1.7 Supply of combustion air and evacuation of combustion products

5.1.7.1 Appliance combustion air inlet

The cross-section of the combustion air passageways to the appliance shall not be adjustable.

5.1.7.2 Appliance flue gas outlet

The cross-section of the appliance flue gas outlet shall not be adjustable.

If the appliance has a POCED that is capable of being installed in accordance with the manufacturer's instructions such that its outlet, when fitted with any terminal supplied with the appliance, or specified in the manufacturer's instructions, extends beyond the external surface of a building by more than 1,5 m, this duct, together with any associated air supply duct (Type C₁ and C₃ appliances), shall not undergo any permanent distortion when subjected to the wind load test specified in 4.3.2 of EN 1859:2000.

5.1.7.3 Type B₁₁, B_{11AS}, B_{11BS} and appliances

All appliances shall be designed so that there is an adequate supply of combustion air during ignition and over the whole range of possible heat inputs stated by the manufacturer.

Connection to the flue shall be made by means of a flue outlet preceded by a draught diverter. This device is part of the appliance. The flue outlet shall be female and shall allow, if necessary by means of an adaptor supplied with the appliance, connection to a flue pipe whose diameter complies with the standards in force where the appliance is to be installed (see A.7). The internal diameter of the flue outlet shall be such as to ensure compliance with requirements concerning operation. It shall be possible to insert a flue pipe of nominal external diameter ($D - 2$) mm to a depth of at least $D/4$ (where D is the internal diameter of the flue outlet) but not so far that the evacuation of the combustion products is impaired.

Appliances shall be constructed to prevent release of combustion products in a dangerous quantity into the installation room under abnormal draught condition (see 6.2.8 and 6.2.9). To meet this requirement, Type B₁₁ appliances shall be factory fitted with a suitable device; in this case the appliance is designated as a Type B_{11AS} or B_{11BS} appliance, according to the device (see 4.2.2.1 for classifications).

However, appliances intended to be installed in a place separated from living rooms and provided with appropriate ventilation directly to the outside need not carry such a device, but in this case, appropriate warnings on the packaging and in the instructions shall clearly indicate the limit on the use of this type of appliance; in this case the appliance is designated as a Type B₁₁ appliance.

The device shall be an integral part of the appliance and resist the thermal, chemical and mechanical effects occurring in normal use. The device shall be protected by the manufacturer against adjustment. The combustion products discharge safety device shall be so designed that it cannot be dismantled without a tool. It shall be difficult to fit the device incorrectly after servicing.

5.1.7.4 Type B₄₁ appliances

The draught diverter shall either be integral with the appliance or be supplied with the appliance by the manufacturer.

The POCED shall either be supplied with the appliance by the manufacturer or specified in the manufacturer's instructions. The specification shall include a description of the duct including any bends, its materials of construction and any critical tolerances (e.g. in length, diameter, thickness, insertion depth).

Appliances shall be constructed to prevent release of combustion products in a dangerous quantity into the installation room under abnormal draught condition (see 6.2.8 and 6.2.9). To meet this requirement, Type B₁₁ appliances shall be factory fitted with a suitable device; in this case the appliance is designated as a Type B_{41AS} or B_{41BS} appliance, according to the device (see 4.2.2.1 for classifications).

However, appliances intended to be installed in a place separated from living rooms and provided with appropriate ventilation directly to the outside need not carry such a device, but in this case, appropriate warnings on the packaging and in the instructions shall clearly indicate the limit on the use of this type of appliance; in this case the appliance is designated as a Type B₄₁ appliance.

The device shall be an integral part of the appliance and resist the thermal, chemical and mechanical effects occurring in normal use. The device shall be protected by the manufacturer against adjustment. The combustion products discharge safety device shall be so designed that it cannot be dismantled without a tool. It shall be difficult to fit the device incorrectly after servicing.

5.1.7.5 Type C₁₁ appliances

5.1.7.5.1 Flue terminal and ducts

The terminal shall be supplied by the appliance manufacturer and any necessary combustion air and combustion products ducts shall be described in the installation instructions.

The flue system shall be designed taking into account the possible penetration of rain or snow.

An opening in a terminal shall not permit the entry of a ball of 16 mm diameter when applied with a force of 5 N. If the terminal performance is dependent on a chamber within the wall, a chamber lining shall be provided with the appliance.

If a Type C₁₁ appliance is fitted with separate combustion air inlet and combustion products ducts, the centres of these ducts shall be in a distance of not more than 500 mm at their termination point.

5.1.7.5.2 Terminal guard

A terminal guard shall be provided in accordance with the National Regulations applicable in the various member states.

5.1.7.6 Type C₂₁ and C₄₁ appliances

All necessary connecting parts to the combustion air/combustion products duct shall be supplied by the appliance manufacturer.

5.1.7.7 Type C₃₁ appliances

5.1.7.7.1 Flue terminal and ducts

The terminal shall be supplied by the appliance manufacturer and any necessary combustion air and combustion products ducts shall be described in the installation instructions.

The flue system shall be designed taking into account the possible penetration of rain or snow.

An opening in a terminal shall not permit the entry of a ball of 35 mm diameter when applied with a force of 5 N.

5.1.7.7.2 Terminal guard

A terminal guard shall be provided in accordance with the National Regulations applicable in the various member states.

5.1.8 Supply and distribution of air for space heating

5.1.8.1 Air inlets

Where the air inlet is intended to be ducted to the heater, the appliance shall be provided with flanges, spigots or other suitable connections on the air inlet.

5.1.8.2 Air outlets

Ducted air heaters shall be capable of being located positively with respect to the outlet ductwork.

5.1.9 Checking the state of operation of the burner

The installer shall be able to observe visually the ignition and correct operation of the burner(s) and also the flame(s) of the ignition burner, if any. A door may be opened or a case removed provided that the operation of the burner is not disturbed.

If the means of observation is a viewing port, it shall, when located in an area of high temperature, be covered with a suitable material, for example heat resistant toughened glass and, if necessary, sealed with a suitable heat resistant sealant.

When the main burner is fitted with its own flame detector, an indirect means of observation (e.g. an indicator light) may be used. This indirect means shall be used only for indicating presence of a flame following a successful ignition or absence of a flame due to failure to ignite or the failure of the flame detector to detect a flame.

It shall be possible for the user, perhaps after opening a door or removing an access panel, to check at any time that the appliance is operating, either by visual observation of the flame or by some other indirect means.

5.1.10 Electrical equipment

The electrical equipment of the appliance shall comply with the relevant requirements of EN 60335-2-102:2006, EN 60730-1:2001 and EN 61058-1:2002.

If the appliance is fitted with electronic components or electronic systems providing a safety function, these shall comply with the relevant requirement of EN 298:2003 with regard to electromagnetic compatibility immunity levels.

If the manufacturer specifies the nature of the electrical protection of the appliance on the data plate, this specification shall comply with EN 60529:1992 in order to:

- a) to give the degree of personal protection against contact with dangerous electrical components inside the appliance case;
- b) to give the degree of electrical protection, inside the appliance case, against harmful actions due to water penetration.

5.1.11 Operational safety in the event of fluctuation, interruption and restoration of the auxiliary energy

Interruption and subsequent restoration of the electricity supply at any time during the starting up or operation of the appliance shall result in:

- a) continued safe operation; or
- b) safety shut-down; or
- c) volatile or non-volatile lock-out

NOTE Requirements and test methods relating to the continued and safe operation of the appliance in the event of normal and abnormal fluctuation of auxiliary energy are specified in 6.2.5.1 and 7.3.5.3 test no.4.

5.1.12 Motors and fans

The direction of rotation of fans shall be clearly marked.

Access to motors and fans shall not be possible without the use of commonly available tools, unless guarded. The guard must comply with IP 20 as a minimum as defined in EN 60529:1992.

Belt drives, where used, shall be so designed or positioned as to afford protection to the operator.

Means shall be provided to facilitate adjustment of belt tension. Access to such means shall be possible only with the use of commonly available tools.

Motors and fans shall be mounted in such a way as to minimize noise and vibration.

Lubrication points, if provided, shall be readily accessible.

The combustion chamber and heat exchanger shall be positioned on the pressure side of the air delivery fan. Products of combustion shall not be drawn into the air distribution system, even when user access panels are removed.

5.1.13 Air filter

An air filter shall be placed upstream of the heat exchanger in the heated air circuit.

It shall be easy to inspect and to replace the filter following the manufacturer's instructions, without requiring special tools.

5.2 Adjusting, control and safety devices

5.2.1 General

All the following devices or the multifunctional control in which they might be fitted shall be removable or exchangeable if this is necessary for cleaning or replacement of the device. Adjusters for the devices shall not be interchangeable if this could result in confusion.

When there are several control knobs (e.g. taps and thermostats), they shall not be interchangeable if this could lead to confusion or they shall be clearly marked to identify their function.

For ducted appliances, gas connections shall be sited externally to the air duct so as to prevent ingress of gas into the duct system.

The functioning of any safety device shall not be overruled by that of any control device.

5.2.2 Gas rate adjusters and range-rating devices

5.2.2.1 Common requirements

Gas rate adjusters and range-rating devices shall be designed so that they are protected against accidental maladjustment by the user once the appliance has been installed and put into service. It shall be possible to seal them (e.g. with paint) after adjustment; this sealing shall resist the heat to which it is subjected during normal operation of the appliance. The adjusting screws of the gas rate adjusters and range-rating devices shall be located so that they cannot fall into the gasways.

The soundness of the gas circuit shall not be put at risk by the presence of gas rate adjusters and range-rating devices.

5.2.2.2 Gas rate adjusters

Appliances in categories I_{2H}, I_{2L}, I_{2E}, I_{2E+}, I_{3B/P}, I_{3P}, II_{2H3B/P}, II_{2H3+}, II_{2H3P}, II_{2L3B/P}, II_{2E3B/P}, II_{2E+3+} and II_{2E+3P} shall not be fitted with gas rate adjusters. However, regulated appliances in all of these categories except Category II_{2E+3+} may have a gas rate adjuster consisting of an adjusting screw on the gas regulator.

Appliances in Category II_{1a2H} shall have a gas rate adjuster for the 1st family gases.

For appliances in categories II_{2H3+} and II_{2E+3+} having a gas rate adjuster, it shall be possible to put these devices out of service when these appliances are supplied with a 3rd family gas, and the same applies for appliances in Category II_{1a2H} when they are supplied with a 2nd family gas. For appliances in Category II_{2E+3P} having a gas rate adjuster, it shall be possible to put these devices out of service fully or partially (see 5.2.5) when these appliances are supplied with a 2nd family gas.

The adjusters shall be adjustable only with a tool and they shall be capable of being set in the operating position.

5.2.2.3 Range-rating devices

A range-rating device on an appliance is optional.

For appliances in Category II_{1a2H}, the gas rate adjuster and the range-rating device may be one and the same. However, if the gas rate adjuster has to be sealed, either completely or partially, when the appliance is supplied with a 2nd family gas, the gas rate adjuster or its sealed part shall no longer be used by the installer as a range-rating device.

5.2.3 Aeration adjusters

Any means of adjusting the primary aeration shall be pre-set and sealed by the manufacturer to discourage unauthorized interference.

5.2.4 Manual controls

5.2.4.1 Application

Manual controls (e.g. valves, push buttons and electrical switches) that are essential for normal operation and commissioning of the appliance shall either be provided with the appliance or, where they are not integral with the appliance, specified in the manufacturer's installation instructions.

5.2.4.2 Manual valves (other than those incorporated in a multifunctional control)

Separate manual valves shall be of the 90° turn type.

Manual valves shall be so designed or positioned as to prevent inadvertent operation but shall be easy to operate when required. They shall be so designed that in operation the "OPEN" and "CLOSED" positions are readily distinguishable.

When an appliance isolating valve is provided as an integral part of the appliance, it shall be capable of operating at a pressure equal to 1,5 times the maximum supply pressure and shall be readily accessible.

Manual valves used solely for OPEN/CLOSED operation shall be provided with positive stops at the "OPEN" AND "CLOSED" positions.

5.2.5 Regulators

Regulators shall comply with the requirements of EN 88-1:2007.

Appliances in categories I_{2H}, I_{2E}, I_{3B/P}, I_{3P}, II_{1a2H}, II_{2H3B/P}, II_{2H3+}, II_{2H3P}, II_{2E3B/P} and II_{2E+3P} shall be fitted with a gas regulator. Appliances in categories I_{2L} and II_{2L3B/P}, may be fitted with a gas regulator. In addition, appliances in categories I_{2E+}, and II_{2E+3+} may be fitted with a gas regulator. However, the regulator, if it exists, shall not be operational in the range of the two normal pressures of the second family pressure couple, i.e. 20-25 mbar.

For appliances in categories II_{2H3+} and II_{2E+3+}, it shall be possible to put the regulator, if any, out of service when they are supplied with third family gases. For appliances in categories II_{2E+3+} and II_{2E+3P}, it shall be possible to put the regulator partially out of service when they are supplied with second family gases, such that the regulator is not operational in the range of the two normal pressures of the second family pressure couple, i.e. 20-25 mbar.

The design and accessibility of the regulator shall be such that it can be easily adjusted or put out of service for use with another gas, but precautions shall be taken to make unauthorized interference with the adjustment difficult.

A regulator is considered to be non-existent if it has been factory sealed in a position such that it is not operational in the range of supply pressure corresponding to the appliance category.

5.2.6 Multifunctional controls

Any multifunctional control shall comply with the requirements of EN 126:2004. In addition, multifunctional controls shall comprise as a minimum the appropriate valving requirements of 5.2.7.2 and 5.2.7.3.

No markings are required if incorrect operation is impossible (e.g. when a single button controls a flame supervision device for the burner and the ignition burner). However, where it is necessary to use markings, they shall be:

- a) Off : full disc;
- b) ignition of the ignition burner (if any) : stylized star;
- c) full rate of the burner : stylized flame.

If the appliance has two separate gas rate controls, one for the burner and one for the ignition burner, the operation of these devices shall be interlocked in such a way that it is impossible for the burner to be supplied before the ignition burner.

If the appliance has a combined gas rate control where the burner and ignition burner are served by a single control, it shall have a stop or notch making the ignition burner position clearly perceptible to the user. It shall be possible to carry out the unlatching operation (if any) with one hand.

A control knob that operates by turning shall turn off in a clockwise direction as seen by an observer facing the knob.

5.2.7 Automatic shut-off valves

5.2.7.1 General

Automatic shut-off valves shall comply with the requirements of EN 161:2002.

Class D valves as specified in 5.2.7.2 and 5.2.7.3 may be replaced by Class C, B or A valves, Class C valves may be replaced by Class B or A valves, and Class B valves may be replaced by Class A valves.

5.2.7.2 Appliances with separate ignition burner

For appliances in which ignition takes place at a separate ignition burner, all gas supplies shall be under the control of automatic shut-off valves connected to the gas line in series, of a capability not less than that specified in Table 2.

Table 2 — Valving requirements for appliances with a separate ignition burner

System	Main gas valves	Start gas valves
Non-automatic with ignition burner	1 Class C + 1 Class D	1 Class C ^a
Automatic with waiting time ^b	1 Class C + 1 Class D	1 Class C ^{c, d}
Automatic without waiting time	1 Class C + 1 Class C, or 1 Class B + 1 Class D	1 Class C ^{c, d}

^a This valve may be the start-gas component integral with a thermoelectric valve or multifunctional control conforming to the requirements of EN 125:1991 or EN 126:2004, as appropriate. This valve need not be in addition to the Class C valve required for main gas control.

^b The waiting time shall be at least 300 s.

^c This valve may be the Class B or C valve controlling the main gas supply.

^d If the ignition burner rate exceeds 0,6 kW, then an additional Class D valve shall be incorporated in the ignition burner supply.

5.2.7.3 Appliances with direct ignition of the main burner

Appliances incorporating direct ignition of the main burner shall be under the control of automatic shut-off valves connected to the gas-line in series, of a capability not less than specified in Table 3.

Table 3 — Valving requirements for appliances with direct ignition of the main burner

System	Gas valves
Type B and C with waiting time ^a	1 Class C + 1 Class D
Type C without waiting time	1 Class C + 1 Class C or 1 Class B + 1 Class D

^{a)} The waiting time shall be at least 300 s.

5.2.7.4 Valve action in case of shut-down

Both safety and controlled shut-down shall at least effect closure of the Class D valve (or its alternative) within 5 s.

5.2.8 Automatic burner control systems

5.2.8.1 General

Automatic burner control systems shall comply with the requirements of EN 298:2003.

5.2.8.2 Manually operated devices

The operation of manually operated devices (e.g. push buttons and switches) incorrectly or out of sequence shall not adversely affect the safety of the automatic burner control system.

In particular, under the test conditions described in 7.2.1, the rapid (on and off) operation of any start switch shall not set up a hazardous condition.

5.2.9 Gas strainers

A strainer shall be fitted at the inlet of any system incorporating automatic shut-off valve(s) to prevent the ingress of foreign matter. The strainer may be integral with the upstream automatic shut-off valve. The maximum strainer hole dimension shall comply with the requirements of EN 161:2002, or shall be 0,2 mm when a Class D valve is used.

In systems comprising multiple automatic shut-off valves, only one strainer need be fitted, provided it gives adequate protection to all valves.

Where a regulator is fitted upstream of the automatic shut-off valve system, the strainer shall be fitted upstream of the regulator.

5.3 Ignition devices

5.3.1 General

It shall be possible to light the appliance from a readily accessible position.

Ignition burners and ignition devices shall be protected by design and position against external influences.

Ignition burners, ignition devices and their mountings shall be so designed that they can only be located rigidly and correctly in relation to every component and burner with which they are designed to operate.

5.3.2 Ignition device for the main burner

The main burner shall be fitted with an ignition burner or an ignition device for direct ignition.

5.3.3 Ignition burners

If different ignition burners are used for the different gases, they shall be marked, easy to substitute for one another and easy to fit. The same applies to injectors where only they have to be changed. Injectors shall carry an indelible means of identification and shall only be removable with the aid of a tool.

Ignition burners shall be protected against blockage by gas-borne particulate matter (see 5.2.9).

5.4 Flame supervision system

5.4.1 General

The burner shall be fitted with a flame supervision device complying with EN 125:1991 or by the flame detector of an automatic burner control system complying with EN 298:2003 to monitor the start-gas flame and protect the main flame.

5.4.2 Appliances with non-automatic burner systems

Upon flame failure, the control system shall cause at least volatile lock-out. The extinction safety time for the flame supervision system to shut down the burner shall not be more than 60 s for appliances with ignition burners protected by a thermoelectric flame supervision system. The extinction safety time is verified under the test conditions of 7.2.3.

Flame supervision devices shall be designed so that:

- a) failure of the sensor causes safe shut down of the burner (e.g. thermoelectric type), or
- b) any automatic shut-off valve opening and/or any ignition attempt occurring is prevented if a flame or flame-simulating condition is signalled when the burner is started from the completely shut-down condition.

NOTE Care should be taken to prevent electrical interference from giving rise to flame detector signals that falsely indicate the presence of a flame.

Where thermoelectric flame supervision devices are used in conjunction with electric ignition, gas shall not flow to the main burner unless the ignition burner is alight when any control tap or equivalent device that is

accessible to the user is turned "OFF" and then "ON" again after 3 s. For the purposes of this requirement, piezoelectric ignition is not regarded as electric ignition.

5.4.3 Appliances with automatic burner systems

When the burner is started from the shut-down condition, the flame supervision system shall prevent any attempt at ignition or the opening of any gas valve if a flame or flame-simulating condition is present. This safe-start check shall last for more than 5 s and shall cease not more than 5 s prior to any attempt at ignition.

Where the flame supervision system incorporates components (e.g. thermionic valves) requiring warm-up time, the safe-start check shall last for at 5 s longer than the maximum warm-up time.

NOTE Care should be taken to prevent electrical interference from giving rise to flame detector signals that falsely indicate the presence of a flame.

Upon flame failure during the running condition, the control system shall cause a safety shut-down or a single attempt at spark restoration. For control systems which incorporate hot surface ignition, safety shut-down and at least volatile lock-out shall result following flame failure. The total extinction safety time for the flame supervision system to detect the absence of flame and shut down the burner(s) shall not be more than 3 s. This is verified under the test conditions of 7.2.3.

5.5 Start-gas flame establishment

5.5.1 Appliances with non-automatic burner systems

Direct ignition of the main burner is not allowed.

The gas rate of an ignition burner shall be as low as possible, consistent with satisfactory ignition and shall not exceed 0,6 kW.

The ignition opening time shall not exceed 30 s. This time is verified under the test conditions of 7.2.2; it can be raised to 60 s if no manual intervention is required during it.

Provision shall be made to establish the start-gas flame safely and easily, either manually or by means of an ignition device incorporated in the appliance. Where an ignition device is incorporated in the appliance, it shall also be possible to ignite the ignition burner by manual means.

Gas shall not be admitted to the main burner until the start-gas flame has been detected by the flame supervision device.

The flame supervision device, under all conditions of operation, shall detect the start-gas flame only at rates which will ignite the main gas reliably and smoothly.

5.5.2 Appliances with automatic burner systems

A start gas flame shall be established either at the main burner or at a separate ignition burner.

The start gas rate shall be such that when tested under the conditions of 7.2.2, the system is safe on ignition.

The flame detector, under all conditions of operation, shall detect the start gas flame only at rates which will ignite the main gas reliably and smoothly.

The first safety time shall not exceed:

- 30 s in case of ignition burners having an input ≤ 600 W;
- 15 s in case of ignition burners having an input > 600 W and $\leq 1,5$ kW;

- 5 s (and preferably not less than 2 s) for appliances where the start-gas rate exceeds 1,5 kW.

The safety time is verified under the conditions of 7.2.4. Moreover, when tested under the conditions of 7.2.4.3, the appliance shall not sustain any damage likely to affect its safe operation.

If ignition does not occur, the spark shall continue until the safety time has elapsed.

The ignition source shall not be energized before a safe-start check has been made of the flame supervision system. The ignition source shall be de-energized at, or before, the end of the first safety time. If the start gas flame has not been detected by the end of the first safety time, safety shut-down and at least volatile lock-out shall result.

In the event of start gas flame failure after establishment of the start gas flame, safety shut-down or a single immediate attempt at re-ignition shall occur for appliances where the start gas rate, established on a separate ignition burner, does not exceed 0,6 kW. If re-ignition is attempted and the start gas flame is not detected within the first safety time, safety shut-down and at least volatile lock-out shall result.

For appliances where the start gas rate exceeds 0,6 kW, safety shut-down and at least volatile lock-out shall occur in the event of start gas flame failure after its establishment.

However, the upstream automatic shut-off valve in the main gas supply may be opened to permit gas flow where the start gas supply is taken from downstream of the first main gas automatic shut-off valve, provided that:

- a means is provided to prove closure of the downstream main shut-off valve prior to ignition;

NOTE A valve proving system, proof of closure switch or closed position indicator switch is deemed to satisfy this requirement.

or,

- the requirement of 6.2.4.1.2 is met.

Where the downstream main gas automatic shut-off valve is a two-stage valve controlling both the start gas rate and the main gas rate, the start position of the valve shall be checked. If the check indicates that the downstream valve is not in the start position, start-up shall be prevented or at least volatile lock-out shall occur.

5.6 Main flame establishment

5.6.1 Appliances with non-automatic burner systems

Main gas shall not be admitted to the burner until the start gas flame has been detected by the flame supervision system and manual intervention has occurred (e.g. release of a push button).

5.6.2 Appliances with automatic burner systems

The main gas automatic shut-off valves shall not be energized to admit the main gas flow to the burner until after the start gas flame has been detected and proved. The second safety time shall not exceed 3 s.

For appliances incorporating direct ignition of the main burner, a single ignition attempt shall be permitted with a safety time not exceeding 5 s. This is verified under the conditions of 7.2.4.

Flame failure up to end of the safety time shall lead to safety shut-down and non-volatile lock-out.

5.7 Main burner

The cross sectional area of the flame ports shall not be adjustable.

Every injector and removable restrictor shall carry an indelible means of identification. It shall be possible to change injectors and restrictors without having to move the appliance from its installed position. However, injectors shall only be removable with the aid of a tool.

The burner shall be so located and arranged that misalignment cannot occur. It shall not be possible to remove the burner assembly without the use of tools.

5.8 Facility for remote control

Where the appliance is capable of being controlled remotely by means of thermostats or a time control, electrical connections of these controls shall be possible without modifying the wiring in the appliance other than a link exclusively designed for this purpose.

When the appliance is installed in accordance with the manufacturer's instructions, no hazardous condition shall occur as a result of failure of the normal means of air temperature control.

5.9 Thermostats and control of air temperature

5.9.1 General requirements

Integral mechanical thermostats shall comply with the requirements of EN 257:1992.

Integral electrical and electronic thermostats shall comply with the requirements of EN 60730-2-1:1997.

Overheat cut-off devices shall comply with Type 2K requirements of EN 60730-2-9:2002.

5.9.2 Overheat limit device

An overheat limit device may be provided to cause shut-down of the main burner in the event of an overheat condition.

Where flame detection is achieved other than by means of a direct-acting thermoelectric device, shut-down action shall not rely on the operation of the flame detection circuits. In particular, the overheat limit device shall not be wired in series with the flame sensor.

5.9.3 Overheat cut-off device

An overheat cut-off device shall be provided to cause shut-down of the main burner in the event of an overheat condition. If, however, the appliance is fitted with an overheat limit device satisfying 7.3.6 Test 2, the overheat cut-off device may be omitted.

5.9.4 Air delivery fan control

5.9.4.1 Delayed start

Means may be provided to delay the operation of the air delivery fan after ignition of the burner in order to prevent the discharge of cold air into the heated space.

5.9.4.2 Delayed shut-down

Means shall be provided to delay the shut-down of the air delivery fan after shut-down of the burner(s).

5.9.5 Sensors

Thermostats, overheat limit and overheat cut-off devices may have the same sensor if such devices are of Type 2 K according to EN 60730-2-9:2002 and failure of the sensor results in safety shut-down, unless this

failure is excluded by construction. Otherwise, thermostats, overheat limit and overheat cut-off devices shall have independent sensors.

5.10 Gas pressure test points

The appliance shall be fitted with at least two gas pressure test points. One shall be fitted upstream of the first control and safety device and the other downstream of the last gas flow rate control and in a position carefully selected so as to permit measurements to be made.

The test points shall have an external diameter of $\left(9 \frac{0}{-0,5}\right)$ mm and a useful length (the straight part) of at least 10 mm to enable a tube to be fitted. At the point of its minimum cross-section, the diameter of the bore shall not exceed 1,0 mm.

6 Operational requirements

6.1 Safety of operation

6.1.1 Soundness

6.1.1.1 Soundness of the gas circuit

The gas circuit shall be sound. External soundness is assured if, under the conditions specified in 7.3.1.1, the air leakage rate does not exceed 100 cm³/h regardless of the number of valves fitted in series or in parallel on the appliance.

6.1.1.2 Soundness of the combustion circuit and correct evacuation of combustion products

6.1.1.2.1 Type B appliances

When the appliance is tested under the conditions of 7.3.1.2.1 combustion products shall not escape except from the flue outlet.

6.1.1.2.2 Type C appliances

When the appliance is tested under the conditions of 7.3.1.2.2 the air leakage rate shall not exceed:

- a) $0,25Q_n$ m³/h for heat inputs not exceeding 16 kW;
- b) 4 m³/h for heat inputs above 16 kW but not exceeding 43,3 kW;
- c) $(0,075Q_n + 0,75)$ m³/h for heat inputs above 43,3 kW but not exceeding 70 kW,

where Q_n is the nominal heat input on net calorific value.

6.1.2 Heat inputs

6.1.2.1 Nominal heat input

When measured under the conditions of 7.3.2.2, the heat input obtained at the normal pressure of appliances without gas rate adjusters, or with factory-adjusted and sealed gas rate adjusters, or with gas rate adjusters set according to the manufacturer's instructions, shall be within ± 5 % of the nominal heat input.

6.1.2.2 Start gas heat input

When measured under the conditions of 7.3.2.3, the heat input of unregulated appliances with factory-adjusted and sealed gas rate adjusters, or with gas rate adjusters set according to the manufacturer's instructions, obtained at normal pressure, shall be within $\pm 5\%$ of the start gas heat input declared by the manufacturer.

However, this tolerance is extended to within $\pm 10\%$ where the injector has a diameter of 0,5 mm or less.

6.1.2.3 Effectiveness of gas rate adjusters

For appliances without a gas regulator but with a gas rate adjuster, the heat input obtained after adjustment of the device shall not:

- a) be less than the nominal heat input, under the conditions of Test 1 of 7.3.2.4;
- b) exceed the nominal heat input, under the conditions of Test 2 of 7.3.2.4.

6.1.2.4 Effectiveness of the gas regulator

For appliances with an adjustable gas regulator, the heat input shall not differ by more than $+7,5\%$ and -10% for 1st family gases, and by more than $+5\%$ or $-7,5\%$ for 2nd and 3rd family gases, from the heat input obtained at the adjustment pressure specified in 7.3.2.5, when the upstream pressure is varied between the minimum and maximum values stated in 7.1.4 for the reference gases of the category concerned.

6.1.2.5 Effectiveness of the range-rating device

For appliances fitted with a range-rating device, and under the conditions specified in 7.3.2.6:

- a) the nominal heat input shall be obtained to within $\pm 5\%$ of the nominal heat input stated by the manufacturer with the range-rating device in the position giving the maximum rate;
- b) the minimum heat input shall be obtained to within $\pm 5\%$ of the minimum heat input stated by the manufacturer with the range-rating device in the position giving the minimum rate.

6.1.3 Limiting temperatures

6.1.3.1 Temperatures of appliance parts which have to be touched

The surface temperatures of the control knobs and of all the parts that have to be touched during normal use of the appliance, measured only in the zones intended to be gripped, and under the conditions stated in 7.3.3.2 shall not exceed the ambient temperature by more than:

- a) 35 K for metals;
- b) 45 K for porcelain or similar materials;
- c) 60 K for plastics.

If, under the conditions stated in 7.3.3.2, the temperature of the end of the gas connection at the appliance inlet exceeds the ambient temperature by more than 30 K, the installation instructions shall state the precautions to be taken in respect of the connection.

6.1.3.2 Temperatures of the appliance surface

When the appliance is tested under the conditions of 7.3.3.3 the temperature of the side walls, the front, the back, the base and the top of the appliance shall not exceed 100 °C, except on working surfaces such as the external primary flue and the draught diverter.

6.1.3.3 Temperatures of the surroundings

Temperatures of the surroundings are deemed irrelevant if:

- a) no parts of the appliance, including working surfaces, have been found to present surface temperatures above 85 °C when tested in accordance with 7.3.3.3; or
- b) the installation instructions specify that the installation room shall not contain combustible materials.

In all other cases, the temperatures found on the test panels described in 7.3.3.4 shall not exceed 85 °C.

6.1.3.4 Component temperatures

When the appliance is tested under the conditions of 7.3.3.5, the maximum temperature of the appliance components shall not exceed the maximum temperature specified by the individual component manufacturer.

6.1.3.5 Fan motor winding temperatures

Electric motors shall be protected to prevent motor windings from overheating. During Test 1 for overheat protection according to 7.3.6, the protection shall not operate.

6.1.3.6 POCED (all Type B₄₁, Type C₁₁ and C₃₁ appliances)

When the appliance is tested under the conditions of 7.3.3.6.1, the external temperature of any part of the POCED, which when installed in accordance with the manufacturer's instructions is capable of being less than 25 mm from combustible parts of the fabric of a building, shall not exceed the ambient temperature by more than 50 K.

If, in accordance with the manufacturer's installation instructions, the POCED is required to be enclosed within another duct, a sleeve or insulation when it passes through a combustible wall or ceiling, the external temperatures of this duct, sleeve or insulation shall not exceed the ambient temperature by more than 50 K under the conditions of 7.3.3.6.2.

6.1.4 Ignition, cross-lighting, flame stability

6.1.4.1 Ignition and cross-lighting

6.1.4.1.1 All appliances (still air conditions)

Under the test conditions described in 7.3.4.1.1, correct and smooth ignition and cross-lighting shall be assured. Where reignition is provided, it shall be assured smoothly and without undue noise.

6.1.4.1.2 Appliances where the start gas is taken from between the two main burner gas valves

Where the gas line is designed such that the gas supply to the start-gas burner is taken from between the two main gas valves, and means is not provided to prove closure of the downstream main shut-off valve prior to ignition, then under the conditions of test described in 7.3.4.1.2, ignition of the start gas shall not give rise to a hazardous situation.

6.1.4.1.3 Special conditions

6.1.4.1.3.1 Type B appliances

Under the conditions of 7.3.4.1.3.1, the ignition burner or the main burner, if ignition occurs at a start gas rate on the main burner, shall ignite without light-back or lift and any flame supervision device shall continue to function normally.

Where ignition is by means of an ignition burner, ignition of the main burner by the ignition burner shall occur without light-back or lift and any flame supervision device shall continue to function normally.

6.1.4.1.3.2 Type C₁₁ appliances

Under the conditions of 7.3.4.1.3.2, ignition of any ignition burner, ignition of the main burner and complete cross-lighting of the main burner shall be correct.

6.1.4.1.3.3 Type C₂₁ and C₄₁ appliances (1st and 2nd family gases)

Under the conditions of 7.3.4.1.3.3, ignition of any ignition burner, ignition of the main burner and complete cross-lighting of the main burner shall be correct.

6.1.4.1.3.4 Type C₃₁ appliances

Under the conditions of 7.3.4.1.3.4, ignition of any ignition burner, ignition of the main burner and complete cross-lighting of the main burner shall be correct.

6.1.4.2 Flame stability

6.1.4.2.1 All appliances (still air conditions)

Under the test conditions described in 7.3.4.2.1, the flames shall be stable. A slight tendency to lift at the moment of ignition is acceptable but the flames shall be stable in normal operation.

6.1.4.2.2 Special conditions

6.1.4.2.2.1 Type B appliances

Under the conditions of 7.3.4.1.3.1 and 7.3.4.2.2, the main burner and any start-gas flames shall remain stable.

6.1.4.2.2.2 Type C₁₁ appliances

Under the conditions of 7.3.4.1.3.2, the main burner and any start-gas flames shall remain stable.

6.1.4.2.2.3 Type C₂₁ and C₄₁ appliances (1st and 2nd family gases)

Under the conditions of 7.3.4.1.3.3, the main burner and any start-gas flames shall remain stable.

6.1.4.2.2.4 Type C₃₁ appliances

Under the conditions of 7.3.4.1.3.4, the main burner and any start-gas flames shall remain stable.

6.1.5 Combustion

6.1.5.1 All appliances (still air conditions)

The CO concentration in the dry air-free combustion products shall not exceed:

- a) 0,10 % when the appliance is supplied with the reference gas under the conditions of 7.3.5.3, Test 1;
- b) 0,20 % when the appliance is supplied with the reference gas under the conditions of 7.3.5.3, Tests 2 and 3, and with the incomplete combustion gas under the conditions of 7.3.5.3, Test 3.
- c) 0,20 % when the appliance is tested under the conditions of 7.3.5.3, Test 4. In addition, the appliance shall ignite and continue to operate.

The test methods are specified in 7.3.5.

6.1.5.2 Special conditions

6.1.5.2.1 Type B appliances

The CO concentration in the dry air-free combustion products shall not exceed 0,2 % when the appliance is supplied with reference gas under the conditions of 7.3.5.4.1.

6.1.5.2.2 Type C₁₁ appliances

The CO concentration in the dry air-free combustion products shall not exceed 0,2 % when the appliance is supplied with reference gas under the conditions of 7.3.5.4.2.

6.1.5.2.3 Type C₂₁ and C₄₁ appliances (1st and 2nd family gases)

The CO concentration in the dry air-free combustion products shall not exceed 0,2 % when the appliance is supplied with reference gas under the conditions of 7.3.5.4.3.

6.1.5.2.4 Type C₃₁ appliances

The CO concentration in the dry air-free combustion products shall not exceed 0,2 % when the appliance is supplied with reference gas under the conditions of 7.3.5.4.4.

6.1.5.3 Other pollutants

Under the test and calculation conditions of 7.3.5.5, the NO_x concentration in the dry air-free combustion products shall not exceed 260 mg/kWh or the manufacturer's declared maximum concentration, whichever is the lower.

For appliances intended to use only third family gases, the limit NO_x value is multiplied by a factor of 1,60. For appliances intended to use propane only, the limit NO_x value is multiplied by a factor of 1,50.

6.1.6 Overheat protection

Under the conditions of 7.3.6:

- a) the gas supply to the burner shall be cut off by either an overheat limit device or an overheat cut-off device to prevent:
 - 1) a hazardous condition;

- 2) any damage to the appliance;
 - 3) the mean temperature of the air at the appliance outlet exceeding 100 °C.
- b) neither the overheat limit device, nor the overheat cut-off device (if fitted) shall operate during the normal cyclic action of the appliance.
 - c) the overheat protection shall stop the gas supply to the main burner before the limit temperatures of the components are reached.
 - d) flame stability shall be satisfactory throughout the test.

6.1.7 Heat exchanger thermal cycling

Under the conditions of 7.3.7, at the completion of the test, the heat exchanger shall comply with 6.2.1.2. In addition, the heat exchanger shall not have any split, opening or perforation visible to the naked eye and at the end of the test there shall be no signs of corrosion that will adversely affect the life of any POCED.

6.1.8 Atmosphere sensing device (Type B_{11AS} and B_{41AS})

6.1.8.1 Normal operating conditions

The appliance shall not shut down under the test conditions described in 7.3.8.2.1.

6.1.8.2 Sealed room conditions

Under the test conditions described in 7.3.8.2.2, the appliance shall go to non-volatile lock-out before the carbon monoxide concentration of the atmosphere in the test room exceeds 200×10^{-6} (V/V).

6.1.9 Combustion products discharge safety system (Type B_{11BS} and B_{41BS})

6.1.9.1 Temperature resistance

After testing in accordance with 7.3.9.1, both the combustion products discharge safety device, its attachment and its wiring shall be undamaged.

6.1.9.2 Switching function

In response to an unsafe situation, the combustion products discharge safety system shall at least perform a safety shut-down of the main burner. If provision is made for automatic reset, the gas supply to the main burner shall remain closed for at least 600 s if the cause of the safety shut-down is not rectified. It is permissible in this case for the combustion products discharge safety system to be incorporated into the control circuit.

Compliance with this requirement is checked as described in 7.3.9.2.

6.1.9.3 Response time at zero flue draught

Under the conditions of 7.3.9.3 the response time of the combustion products discharge safety system shall not exceed 120 s at nominal heat input or at the maximum heat input in case of an appliance with variable heat input or a range-rated appliance.

In case of a range-rated appliance or an appliance with variable heat input control it is a further requirement that the response time shall not exceed 240 s at 50 % of the maximum heat input.

If the lowest value of the heat input range and/or control range is more than 50 % of the maximum heat input, this test shall be carried out at this lowest value. The response time of the combustion products discharge safety system shall not exceed T_r seconds, determined using Equation (1).

$$T_r \leq 120 \times \frac{Q_{\max}}{Q_{\min}} \quad (1)$$

where

T_r is the response time of the combustion products discharge safety system in seconds (s);

Q_{\max} is the maximum or nominal heat input in kilowatts (kW);

Q_{\min} is the minimum heat input of the (control) range in kilowatts (kW).

6.1.9.4 Unintentional shut-down

Under the conditions of 7.3.9.4 the combustion products discharge safety device shall not come into operation at the nominal heat input or at the maximum heat input in case of a range-rated appliance.

6.1.9.5 Operation at partial leakage or reduced draught

The response time of the combustion products discharge safety system shall not exceed 600 s when tested under conditions of partial leakage of combustion products in accordance with 7.3.9.5.

6.1.9.6 Behaviour in the event of a sensor defect

In the event of the sensor becoming defective, the combustion products discharge safety system shall at least perform a safety shut-down of the main burner. A shut-down without lock-out is permissible in the case where the gas supply to the main burner is interrupted for at least 600 s as a result of a defective sensor. In this case, the main burner shall not continue to burn for more than 120 s.

Compliance with this requirement is checked in 7.3.9.6.

6.2 Efficiency

The efficiency based on the net calorific value determined at the nominal heat input shall not be less than 84 % when measured in accordance with 7.4.1 to 7.4.5.

If the appliance has a modulating or high/low control, when measured in accordance with 7.4.6, the efficiency, based on the net calorific value with the appliance adjusted to give the minimum rate, is given by Equation (2).

$$\eta_{\min} \geq \eta_n - \frac{10(Q_n - Q_{\min})}{Q_n} \% \quad (2)$$

where

η_{\min} is the net calorific value determined at the nominal heat input;

η_n is the net calorific value with the appliance adjusted to give the minimum rate;

Q_n is the heat input at nominal rate;

Q_{\min} is the heat input at minimum rate.

Under no circumstances shall η_{\min} be less than 79 %.

7 Test methods

7.1 General

7.1.1 Characteristics of test gases (reference and limit gases)

Appliances are intended for use with gases of different qualities. One of the aims of this standard is to check that the performance of an appliance is satisfactory for each family or group of gases for which it is designed and for the pressures for which it is designed, if necessary using the adjusting devices.

The test gases, test pressures and appliance categories given in this Standard are in accordance with those specified in EN 437:2003.

The characteristics of the reference and limit gases are given in Tables 4 and 5. The values in Table 3, measured and expressed at 15 °C, are derived from ISO 6976:2005.

7.1.2 Conditions for preparation of the test gases

The composition of gases used for the tests shall be as near as possible to those given in Table 4.

For the constitution of the gases:

- a) the Wobbe number of the gas used shall be within ± 2 % of the value in Table 4 (this tolerance includes measuring equipment errors);
- b) the purity of the gases used to constitute the mixtures shall be:
 - 1) Nitrogen (N_2) - 99 %;
 - 2) hydrogen (H_2) - 99 %;
 - 3) methane (CH_4) - 95 % (with a total concentration of H_2 , CO and O_2 below 1 %);
 - 4) propene (C_3H_6) - 95 % (and a total concentration of N_2 and CO_2 below 2 %);
 - 5) propane (C_3H_8) - 95 %;
 - 6) butane (C_4H_{10})²⁾ - 95 %).

However, these conditions are not obligatory for each of the components if the final mixture has a composition identical to that of a mixture which would have been made from components satisfying the preceding conditions. One can therefore, in order to make up a mixture, start with a gas already containing, in suitable proportions, several components of the final mixture.

For gases of the second family:

- c) for the tests carried out with reference gases G 20 or G 25, a gas belonging respectively to either Group H or Group L or Group E, may be used even if its composition does not satisfy the above conditions, provided that after the addition of either propane or nitrogen as appropriate, the final mixture has a Wobbe index within ± 2 % of the value given in Table 4 for the corresponding reference gas;

2) Any mixture of iso-butane and n-butane can be used.

- d) for preparation of the limit gases, another gas may be used as the base gas instead of methane:
 - 1) for limit gases G 21, G 222, and G 23, a natural gas of Group H may be used;
 - 2) for limit gases G 27 and G 231, a natural gas of Group H or of Group L or of Group E may be used;
 - 3) for the limit gas G 26, a natural gas of Group L may be used.

In all cases the final mixture obtained by adding propane or nitrogen shall have a Wobbe index within $\pm 2\%$ of the value given in Table 4 for the corresponding limit gas and the hydrogen concentration of the final mixture shall be as given in Table 4.

Table 4 — Test gas characteristics^{a)} (gas dry at 15 °C and 1 013,25 mbar)

Gas family and group	Test gases	Designation	Composition volume %	W_i MJ/m ³	H_i MJ/m ³	W_s MJ/m ³	H_s MJ/m ³	d mm
Gases of the first family ^{b)}								
Group a	Reference gas Incomplete, combustion flame lift and sooting limit gases	G 110	CH ₄ = 26 H ₂ = 50 N ₂ = 24	21,76	13,95	24,75	15,87	0,411
	Light back limit gas	G 112	CH ₄ = 17 H ₂ = 59 N ₂ = 24	19,48	11,81	22,36	13,56	0,367
Gases of the second family								
Group H	Reference gas	G 20	CH ₄ = 100	45,67	34,02	50,72	37,78	0,555
	Incomplete combustion Sooting limit gas	G 21	CH ₄ = 87 C ₃ H ₈ = 13	49,60	41,01	54,76	45,28	0,684
	Light back limit gas	G 222	CH ₄ = 77 H ₂ = 23	42,87	28,53	47,87	31,86	0,443
	Flame lift limit gas	G 23	CH ₄ = 92,5 N ₂ = 7,5	41,11	31,46	45,66	34,95	0,586
Group L	Reference gas and Light back limit gas	G 25	CH ₄ = 86 N ₂ = 14	37,38	29,25	41,52	32,49	0,612
	Incomplete combustion and Sooting limit gas	G 26	CH ₄ = 80 C ₃ H ₈ = 7 N ₂ = 13	40,52	33,36	44,83	36,91	0,678
	Flame lift limit gas	G 27	CH ₄ = 82 N ₂ = 18	35,17	27,89	39,06	30,98	0,629
Group E	Reference gas	G 20	CH ₄ = 100	45,67	34,02	50,72	37,78	0,555
	Incomplete combustion and Sooting limit gas	G 21	CH ₄ = 87 C ₃ H ₈ = 13	49,60	41,01	54,76	45,28	0,684
	Light back limit gas	G 222	CH ₄ = 77 H ₂ = 23	42,87	28,53	47,87	31,86	0,443
	Flame lift limit gas	G 231	CH ₄ = 85 N ₂ = 15	36,82	28,91	40,90	32,11	0,617
Gases of the third family ^{c)}								
Third family and groups 3B/P and 3B	Reference gas, Incomplete combustion and Sooting limit gas	G 30	nC ₄ H ₁₀ = 50 iC ₄ H ₁₀ = 50	80,58	116,0 9	87,33	125,81	2,075
	Flame lift limit gas	G 31	C ₃ H ₈ = 100	70,69	88,00	76,84	95,65	1,550
	Light back limit gas	G 32	C ₃ H ₆ = 100	68,14	82,78	72,86	88,52	1,476
Group 3P	Reference gas, Incomplete combustion Sooting ^{d)} and flame lift limit gas	G 31	C ₃ H ₈ = 100	70,69	88,00	76,84	95,65	1,550
	Light back and Sooting limit gas ^{d)}	G 32	C ₃ H ₆ = 100	68,14	82,78	72,86	88,52	1,476
^{a)} For gases used nationally or locally, see A.4. ^{b)} For other groups, see A.4. ^{c)} See also Table 5. ^{d)} See 7.1.2 footnote 4).								

Table 5 — Calorific values of third family test gases

Test gas designation	H_i MJ/kg	H_s MJ/kg
G 30	45,65	49,47
G 31	46,34	50,37
G 32	45,77	48,94

7.1.3 Practical application of test gases**7.1.3.1 Choice of test gases**

Gases required for the tests described in 7.3.5 and 7.3.6 shall be as specified in 7.1.1 and made up in accordance with 7.1.2.

For the tests described in other clauses, it is permissible, in order to facilitate testing, to replace the reference gas by a gas actually distributed, provided that its Wobbe index is within $\pm 5\%$ of that of the reference gas.

When an appliance can use gases of several groups or families, test gases selected from those listed in Table 3 and in accordance with the requirements of 7.1.5.1, are used. The selected gases, for each appliance category, are listed in Table 6.

Table 6 — Test gases corresponding to the appliance categories

Category	Reference gas	Incomplete combustion limit gas	Light back limit gas	Lift limit gas	Sooting limit gas
I _{2H}	G 20	G 21	G 222	G 23	G 21
I _{2L}	G 25	G 26	G 25	G 27	G 26
I _{2E} , I _{2E+}	G 20	G 21	G 222	G 231	G 21
I _{3B/P} , I ₃₊	G 30	G 30	G 32	G 31	G 30
I _{3P}	G 31	G 31	G 32	G 31	G 31, G 32
II _{1a2H}	G 110, G 20	G 21	G 112	G 23	G 21
II _{2H3B/P} , II _{2H3+}	G 20, G 30	G 21	G 222, G 32	G 23, G 31	G 30
II _{2H3P}	G 20, G 31	G 21	G 222, G 32	G 23, G 31	G 31, G 32
II _{2L3B/P}	G 25, G 30	G 26	G 32	G 27, G 31	G 30
II _{2L3P}	G 25, G 31	G 26	G 32	G 27, G 31	G 31, G 32
II _{2E3B/P} , II _{2E+3+}	G 20, G 30	G 21	G 222, G 32	G 231, G 31	G 30
II _{2E+3P}	G 20, G 31	G 21	G 222, G 32	G 231, G 31	G 31, G 32

NOTE Tests with the limit gases are carried out with the injector and adjustment corresponding to the reference gas of the group to which the limit gas used for the test belongs.

7.1.3.2 Conditions of supply and adjustment of the burners**7.1.3.2.1 Initial adjustment of appliance**

Before all tests that are required to be carried out, the appliance shall be fitted with the appropriate equipment (injector(s)) corresponding to the gas family or gas group to which the specified test gas belongs (see Table 6). Any gas rate adjusters are set in accordance with the manufacturer's instructions using the appropriate reference gas(es) (see 7.1.5.1) and the corresponding normal pressure(s) given in 7.1.4.

This initial adjustment of the appliance is subject to the limitations given in 5.1.1.

7.1.3.2.2 Supply pressures

Except where an adjustment of the supply pressure is necessary (as described in 7.1.3.2.3 and 7.1.3.2.4) the normal, minimum and maximum supply pressures to be used for testing purposes shall be in accordance with the requirements given in 7.1.4.

Unless otherwise specified, the initial adjustment of the appliance is not altered.

7.1.3.2.3 Adjustment of heat inputs

For tests requiring adjustment of the burner to the nominal or another specified heat input, it shall be ensured that the pressure upstream of the injectors is such that the heat input obtained is within $\pm 2\%$ of that specified (by altering the preset adjusters or the appliance regulator, if adjustable, or the appliance supply pressure).

The specified heat input shall be calculated in accordance with 7.3.2 and with the appliance supplied with the appropriate reference gas(es).

7.1.3.2.4 Corrected pressures

Where, in order to obtain the nominal heat input within $\pm 2\%$, it is necessary to use a supply pressure, p , different from the normal pressure p_n , then those tests normally carried out at the minimum or maximum pressures p_{\min} and p_{\max} shall be carried out at the corrected pressures p' and p'' .

The corrected test pressures are calculated using Equation (3).

$$\frac{p'_{\min}}{p_{\min}} = \frac{p'_{\max}}{p_{\max}} = \frac{p}{p_n} \quad (3)$$

where

- p_n is the normal test pressure;
- p_{\min} is the minimum test pressure;
- p_{\max} is the maximum test pressure;
- p is the burner unit inlet pressure;
- p'_{\min} is the corrected minimum test pressure;
- p'_{\max} is the corrected maximum test pressure.

7.1.4 Test pressures

The test pressures, i.e. the pressures required at the gas inlet connection of the appliance, are given in Table 7.

These pressures and the corresponding injectors are used in accordance with the special national conditions given in Annex A, for the country in which the appliance is to be installed.

Table 7 — Test pressures

Appliance categories carrying as index	Test gas	p_n mbar	p_{min} mbar	p_{max} mbar
1st family: 1a	G 110, G 112	8	6	15
2nd family: 2H	G 20, G 21, G 222, G 23	20	17	25
2nd family: 2L	G 25, G 26, G 27	25	20	30
2nd family: 2E	G 20, G 21, G 222, G 231	20	17	25
2nd family: 2E+	G 20, G 21, G 222	20	17 ^b	25
	G 231	(25) ^a	17 ^b	30
3rd family: 3B/P	G 30, G 31, G 32	29 ^c	25	35
	G 30, G 31, G 32	50	42,5	57,5
3rd family: 3P	G 31, G 32	37	25	45
	G 31, G 32	50	42,5	57,5
3rd family: 3+ (28-30/37 couple)	G 30	29 ^c	20	35
	G 31, G 32	37	25	45
3rd family: 3+ (50-67 couple)	G 30	50	42,5	57,5
	G 31, G 32	67	50	80
^a This pressure corresponds to the use of low Wobbe index gas but in principle no test is carried out at this pressure. ^b See Annex D. ^c Appliances of this category may be used without adjustment at the specified supply pressures of 28 mbar to 30 mbar.				

7.1.5 Test procedures

7.1.5.1 Tests requiring the use of reference gases

The tests specified in 7.3.2, 7.3.3, 7.3.6, 7.3.7, 7.3.8, 7.3.9 and 7.4 shall be carried out with the reference gas(es) appropriate to the country in which the appliance is to be installed, according to the information given in Table A.1 and the category of the appliance.

The other tests are carried out with only one of the reference gases of the appliance category (see 7.1.1) at one of the normal test pressures required in 7.1.4 for the selected reference gas, hereafter referred to as "the reference gas".

However, the test pressure shall be one of those stated by the manufacturer and the appliance shall be fitted with the appropriate injectors.

7.1.5.2 Tests requiring the use of limit gases

These tests shall be carried out with the limit gases appropriate to the appliance category (see Table 6) and with the injector(s) and the adjustments corresponding to the reference gas of the group, or family, to which each limit gas belongs.

7.1.6 General test conditions

7.1.6.1 to 7.1.6.7 are generally applicable except where otherwise specified.

7.1.6.1 Test room

The appliance is installed in a well ventilated, draught free room which has an ambient temperature of 20 °C ± 5 °C.

NOTE A wider temperature range is permissible provided that the effect on the test result can be taken into account.

7.1.6.2 Evacuation of the products of combustion

7.1.6.2.1 Type B₁₁ appliances

Appliances with a vertical flue outlet shall be tested with the minimum height of vertical flue downstream of the draught diverter specified by the manufacturer. The flue shall have the same nominal diameter as the flue outlet.

Appliances with a horizontal flue outlet shall be fitted in accordance with the manufacturer's instructions; these shall include the maximum length of horizontal run and the method of adaption to a vertical flue; thereafter the vertical flue shall be fitted as above.

The vertical flue shall be made from sheet metal having a metal thickness not exceeding 1 mm. Unless otherwise stated, the flue shall be uninsulated.

7.1.6.2.2 Type B₄₁ appliances

Appliances shall be tested with the POCED as supplied or specified by the appliance manufacturer, having the maximum equivalent resistance specified in the manufacturer's instructions.

7.1.6.2.3 Type C₁₁ appliances

Except where otherwise stated, the lengths of the air supply duct and combustion products duct (POCED) are adjusted to suit a wall thickness of approximately 350 mm, and any terminal guard provided is not fitted. If appropriate, an external telescopic duct is sealed in accordance with the manufacturer's instructions.

7.1.6.2.4 Type C₂₁ and C₄₁ appliances

Appliances shall be tested with the connecting ducts (for the combustion air and for the combustion products) assembled in accordance with the manufacturer's instructions, but, except where otherwise stated, not connected to a test duct.

7.1.6.2.5 Type C₃₁ appliances

Except where otherwise stated, the lengths of the combustion air supply duct and combustion products duct (POCED) are each of the maximum length as stated by the manufacturer.

7.1.6.3 Test installation

The appliance shall be installed in accordance with the manufacturer's instructions, with particular reference to minimum declared clearances around the appliance.

7.1.6.4 Influence of thermostats

Precautions shall be taken to prevent thermostats or other controls from operating and affecting the gas rate, unless this is necessary for the test.

7.1.6.5 Electrical supply

The appliance is connected to an electrical supply at the nominal voltage, except where otherwise stated in the clause concerned.

7.1.6.6 Range-rated appliances

For appliances that are designed to be range-rated, all tests are carried out at their maximum and minimum heat inputs, except where otherwise stated.

7.1.6.7 Modulating and high/low operation

For appliances with modulating or high/low operation, the tests are carried out at the nominal heat input unless otherwise stated in the particular test.

7.2 Construction and design

7.2.1 Automatic burner control systems (manually operated devices)

The appliance is installed as described in 7.1.5 and supplied with an appropriate reference gas (see Table 6) at the nominal heat input in accordance with 7.1.3.3.1. The start device is manually operated 10 times, once every 5 s. It is checked whether the requirement of 5.2.8.2 is satisfied.

7.2.2 Ignition opening time

With the appliance in the cold condition, the gas supply is turned on and the ignition burner is lit 30 s after ignition of the ignition burner, manual intervention is withdrawn and it is checked that the ignition burner remains alight. It is checked whether the requirements of 5.5.1 and 5.5.2 are satisfied.

7.2.3 Extinction safety time

With the appliance in the running condition, isolate the gas supply to the main burner. Measure the time between when the main burner is extinguished and the safety valve is closed. It is checked that the requirements of 5.4.2 and 5.4.3 are satisfied.

7.2.4 Safety times

7.2.4.1 First safety time

Isolate the gas supply to the appliance. Attempt to light the appliance in accordance with the manufacturer's instructions, and measure the time between the signals for valve opening and closure. Compare this time with the manufacturer's specified safety time. It is checked that the requirements of 5.5.2 and 5.6.2 are satisfied.

7.2.4.2 Second safety time

Isolate the gas supply to the main burner only. Attempt to light the appliance in accordance with the manufacturer's instructions, and measure the time between the signals for valve opening and closure. Compare this time with the manufacturer's specified safety time. It is checked that the requirements of 5.6.2 are satisfied.

7.2.4.3 Delayed ignition

The appliance is installed as described in 7.1.5 and initially adjusted in accordance with the requirements of 7.1.3.3.1 and supplied with an appropriate reference gas (see Table 6) at the nominal heat input.

Ignition of the ignition burner or the main burner, if this is ignited directly, is checked. The test is repeated, progressively delaying the ignition up to the end of the safety time.

In order to delay the ignition it will generally be necessary to provide independent control of the main gas or start gas automatic shut-off valves and the operation of the ignition device. A suitable arrangement is to provide a voltage supply, independent of the automatic burner control system, to the relevant gas valve(s) and to the ignition device. For safety reasons, the ignition delay should be increased in stages.

It is checked that the requirements of 5.5.2 are satisfied.

7.3 Safety of operation

7.3.1 Soundness

7.3.1.1 Soundness of the gas circuit

The tests are carried out with an air inlet pressure of 50 mbar or 1,5 times the applicable maximum pressure stated in Table 7, whichever is the greater.

Any regulator may be locked in its maximum open position to avoid damage.

Compliance with the requirements of 6.2.1.1 is checked under each of the following conditions:

- a) each valve in the main gas supply is tested in turn for soundness in its closed position, all other valves being open;
- b) with all gas valves open and the injectors for any ignition burner and main burner sealed, or, alternatively, with the injector(s) removed and the hole(s) sealed.

Where the design of any ignition burner is such that its gas outlet cannot be sealed, this test is carried out with the gasway to the ignition burner sealed at a convenient place. In this case, an additional test is also carried out, using soap solution, to verify that there is no leakage from the gasway downstream of the previously tested section when the ignition burner is operating at its normal working pressure.

For the determination of the leakage rate a volumetric method is used which gives a direct reading of the leakage rate and which is of such accuracy that the error in its determination does not exceed 0,01 dm³/h.

These tests are carried out first when the appliance is delivered and again, on completion of all the tests in the standard, after any assembly in the gas circuit that has a gas-tight joint whose removal is provided for in the manufacturer's instructions has been removed and replaced 5 times.

7.3.1.2 Soundness of the combustion circuit and correct evacuation of the combustion products

7.3.1.2.1 Type B appliances

The appliance is installed as described in 7.1.5 and connected to a flue as described in 7.1.6.2. The test is carried out after operating the appliance for 10 min starting from cold condition, burning one of the reference gases for the category concerned at the nominal heat input.

Possible leaks are looked for with a dew plate, whose temperature is maintained at a value slightly above the dewpoint temperature of the ambient air. The plate is brought near to all the places where a leak could be suspected.

During the test there should not be any dew visible on the plate. In doubtful cases, however, leaks are looked for with a sampling probe connected to a CO₂ analyzer. Any instrument used shall be sensitive to a concentration of 0,01 % CO₂. An increase in the CO₂ level above the ambient of more than 0,05 % shall be regarded as unsatisfactory. In this case, precautions shall be taken to ensure that sampling does not interfere with the normal evacuation of the combustion products.

It is checked that the requirements of 6.2.1.2.1 are satisfied.

7.3.1.2.2 Type C appliances

7.3.1.2.2.1 General

The appliances are installed as described below for each specific Type C appliance. The terminals or ducts for combustion air and combustion products are sealed at the ends, any lighting door is closed and the gas inlet to the main burner and any ignition burner is blocked.

Air is passed into the appliance and the air flow rate is noted when the pressure inside the appliance is steady at 0,5 mbar overpressure.

7.3.1.2.2.2 Type C₁₁ appliances

The appliance is installed as described in 7.1.5 and connected to the combustion air and combustion products duct(s) which belong to the appliance, adjusted as stated in 7.1.6.2.2. It is checked that the requirements of 6.2.1.2.2 are satisfied.

7.3.1.2.2.3 Type C₂₁ and C₄₁ appliances

The appliance is installed as described in 7.1.5 and adjusted as stated in 7.1.6.2.3. It is checked that the requirements of 6.2.1.2.2 are satisfied.

7.3.1.2.2.4 Type C₃₁ appliances

The appliance is installed as described in 7.1.5 and connected to the combustion air and combustion products ducts which belong to the appliance, adjusted as stated in 7.1.6.2.4. It is checked that the requirements of 6.2.1.2.2 are satisfied.

7.3.2 Heat inputs

7.3.2.1 General

For the purposes of this standard all heat inputs are determined from the volumetric rate (V_o) or mass rate (M_o) which relate to the rate obtained with reference gas under reference test conditions (dry gas, 15 °C, 1 013,25 mbar). The heat input (Q_o) in kW is given by:

$$Q_o^{3)} = 0,278 M_o \cdot H_s; \text{ or}$$

$$Q_o = 0,278 M_o \cdot H_i; \text{ or}$$

$$Q_o = 0,278 V_o \cdot H_s; \text{ or}$$

$$Q_o = 0,278 V_o \cdot H_i.$$

3) The heat input based on gross calorific value is related to the net value for the five reference gases as follows:

G 110 gross value = 1,136 × net value, G 120 gross value = 1,093 × net value, G 20 gross value = 1,111 × net value, G 25 gross value = 1,110 × net value and G 30 gross value = 1,083 × net value

where

M_0 is the mass input in kilograms per hour obtained at reference conditions in kg/h;

V_0 is the volume input in cubic metres per hour obtained at reference conditions in m³/h;

H_i is the net calorific value of the reference gas in MJ/kg or in MJ/m³ (dry gas, 15 °C, 1 013,25 mbar), as appropriate;

H_s is the gross calorific value of the reference gas in MJ/kg or in MJ/m³ (dry gas, 15 °C, 1 013,25 mbar), as appropriate.

The mass and volume rates correspond to a measurement and to a flow of reference gas, under reference conditions, in other words assuming the gas to be dry, at 15 °C and under a pressure of 1 013,25 mbar.

In practice, the values obtained during the tests do not correspond to these reference conditions so they shall then be corrected so as to bring them to the values that would actually have been obtained if these reference conditions had existed at the injector outlet during the test.

Depending whether the mass input it is determined from the mass or volume rate, the corrected rate is calculated using Equations (4) and (5) respectively.

$$M_0 = M \sqrt{\frac{1013,25 + p}{p_a + p} \times \frac{273 + t_g}{288} \times \frac{d_r}{d}} \quad (4)$$

$$V_0 = V \sqrt{\frac{1013,25 + p}{1013,25} \times \frac{p_a + p}{1013,25} \times \frac{288}{273 + t_g} \times \frac{d}{d_r}} \quad (5)$$

The corrected mass rate is calculated using Equation (6).

$$M_0 = 1,226 V_0 \times d \quad (6)$$

where

M_0 is the corrected mass flow rate (kg/h), obtained under test conditions;

M is the mass flow rate (kg/h), obtained under test conditions;

p_a is the atmospheric pressure (mbar);

p is the gas supply pressure (mbar);

t_g is the temperature of the gas at the measuring point (°C);

d is the density of dry gas relative to dry air;

d_r is the density of the reference gas relative to dry air.

Equations (4), (5) and (6) are used to calculate, from the mass input, M , or volume input, V , measured during the test, the corresponding rates M_0 or V_0 which would have been obtained under the reference conditions.

Equations (4), (5) and (6) are applicable if the test gas used is dry.

If a wet gas meter (water filled) is used or if the gas used is saturated, the value d (density of dry gas in relation to dry air) is replaced by the value of the density of the wet gas, d_w , given by Equation (7).

$$d_h = \frac{d(p_a + p - p_w) + 0,622 p_w}{p_a + p} \quad (7)$$

where

p_w is the saturation vapour pressure of the test gas expressed in mbar at the temperature t_g .

7.3.2.2 Nominal heat input

The tests are carried out at the pressure specified by the manufacturer in accordance with the requirements of 7.1.4. The appliance is fitted successively with each of the injectors, prescribed by the manufacturer for each gas group and adjusted in accordance with 7.1.3.2.1.

The heat input is determined as described in 7.3.2.1 for each reference gas. The measurements are taken with the appliance at thermal equilibrium and with any thermostat put out of action. The heat input obtained, Q_o , corrected according to 7.3.2.1, is compared with the nominal heat input Q_n in order to verify the requirements of 6.2.2.1.

7.3.2.3 Start gas heat input

The tests are carried out at the pressure specified by the manufacturer in accordance with the requirements of 7.1.4, using an arrangement which allows operation of the start gas flame on its own.

The appliance is fitted successively with each of the injectors, prescribed by the manufacturer for each gas group and adjusted in accordance with 7.1.3.2.1. The heat input is determined as described in 7.3.2.1 for each reference gas. The measurements are taken immediately after ignition of the start gas flame. The heat input obtained is compared with the start gas heat input declared by the manufacturer in order to verify the requirements of 6.2.2.2.

7.3.2.4 Effectiveness of the gas rate adjusters

This clause concerns only appliances fitted with gas rate adjusters which are not put out of action.

Test 1 The rate is measured with the adjuster fully open and with the minimum supply pressure given in 7.1.4 for the particular reference gas.

Test 2 The rate is measured with the adjuster fully closed and with the maximum supply pressure given in 7.1.4 for the particular reference gas.

The tests are carried out for each reference gas for the appliance category with the exception of cases where the adjuster has been set by the manufacturer in a given position. In this case, the adjuster is regarded as non-existent.

It is checked that the requirements of 6.2.2.3 are satisfied.

7.3.2.5 Effectiveness of the gas regulator

If the appliance has an adjustable regulator, this is adjusted if necessary to give the nominal volumetric rate with reference gas at the normal pressure given in 7.1.4 and corresponding to this gas. Keeping the initial adjustment, the supply pressure is varied between the corresponding minimum and maximum values.

This test is carried out for all the reference gases for which the regulator is not put out of action. However, for 1st family gases, this check is made between the normal pressure and the maximum pressure.

It is checked that the requirements of 6.2.2.4 are satisfied.

7.3.2.6 Effectiveness of the range-rating device

The appliance is adjusted in accordance with the installation instructions. The tests are carried out as described in 7.3.2.2 for the two extreme positions of the range-rating device. It is checked that the requirements of 6.2.2.5 are satisfied.

7.3.3 Limiting temperatures

7.3.3.1 General

The appliance is operated with any reference gas for the appliance category at the nominal heat input, the minimum circulated air rate corresponding with the response level of the overheat limit device or overheat cut-off device as preset by the manufacturer and any adjustable thermostat at maximum setting. Unless otherwise specified, the tests are carried out with the appliance at thermal equilibrium.

The minimum air rate at which the overheat limit device or overheat cut-off device responds is detected as described in 7.3.6.

For ductless heaters, the discharge louvres shall be set at the position of closure corresponding with the response of the overheat limit device or overheat cut-off device as preset by the manufacturer.

Range-rated appliances are operated at the maximum heat input.

7.3.3.2 Temperatures of appliance parts which have to be touched

Under the test conditions of 7.3.3.1, the temperatures of the parts specified in 6.1.3.1 are measured to an accuracy of ± 2 K using for instance contact thermocouples, and compliance with 6.1.3.1 is verified.

7.3.3.3 Temperatures of the appliance surface

Under the test conditions of 7.3.3.1, the appliance is operated until the rise of the case temperature does not exceed 2 K/10 min.

The temperatures of the hottest parts of the appliance surface are measured by a suitable means with an accuracy of ± 2 K (e.g. thermocouples with sensing elements applied against the external surfaces of the parts concerned).

It is checked that the requirements of 6.1.3.2 are satisfied.

7.3.3.4 Temperatures of the surroundings

The appliance is installed on, under or opposite to a 20 mm thick oak panel painted a dull black with the minimum clearances and, if applicable, the indicated methods of protecting walls and ceilings as specified in the manufacturer's instructions.

After the appliance has been in operation for at least 30 min or, if necessary, sufficiently longer to reach thermal equilibrium, the temperature of the above panel is determined by means of suitable surface temperature sensing instruments or temperature-sensitive chemicals. At abnormal temperatures, the panel temperatures should be calculated by interpolation.

The test is repeated until the thermal effect of all parts hotter than 85 °C has been established. It is checked that the requirements of 6.1.3.3 are met.

7.3.3.5 Component temperatures

If a maximum temperature is stated and defined for a specific point on the surface of the component by the component manufacturer, this temperature has to be checked when thermal equilibrium has been reached in the test described in 7.3.3.1.

If there is no specific point defined by the component manufacturer, the direct ambient temperature is measured within a distance of 20 mm from the component by means of a sensing element which is accurate within ± 2 K.

The measured ambient temperature has to be checked with the maximum allowed ambient temperature as stated by the component manufacturer, with the appliance installed as described in 7.3.3.1.

The temperature measurements of the components are deemed to be satisfactory if:

$$t_m \leq t_s + t_a - 25 \text{ }^\circ\text{C}$$

where

t_m is the maximum temperature measured in the test in $^\circ\text{C}$;

t_s is the maximum temperature specified by the component manufacturer in $^\circ\text{C}$;

t_a is the ambient room temperature in $^\circ\text{C}$.

NOTE If the maximum temperature of the component was specified for an ambient temperature other than $25 \text{ }^\circ\text{C}$, this shall be used.

It is checked that the requirements of 6.1.3.4 are satisfied.

7.3.3.6 POCED (Type B₄₁, C₁₁ and C₃₁ appliances)

7.3.3.6.1 Test 1

This test is carried out if, when the appliance is installed in accordance with the manufacturer's instructions, any part of the POCED is capable of being less than 25 mm from combustible parts of the fabric of the building.

Install the appliance in accordance with 7.1.6.3 and attach thermocouples junctions to the external surface of those parts of the POCED that are capable of being less than 25 mm from combustible parts of the fabric of the building. Thermocouples shall be used in accordance with EN 60584-1:1995 with the limits of accuracy of the thermoelectric voltage used in accordance with Class 2 of EN 60584-2:1993.

The appliance is supplied with one of the reference gases indicated in 7.1.1 according to its category and adjusted in accordance with 7.1.3.2.1.

The test is carried out with the appliance operating at its nominal heat input. All measurements are taken when thermal equilibrium has been reached. It is recommended that for this test the appliance should be placed in a room where the ambient temperature is approximately $20 \text{ }^\circ\text{C}$.

At the end of the test, check that the maximum temperature rise of the POCED does not exceed the limit specified in 6.1.3.6.

7.3.3.6.2 Test 2

This test is carried out if, in accordance with the manufacturer's installation instructions, the POCED is required to be enclosed within another duct, a sleeve or insulation when it passes through a combustible wall or ceiling.

Install the appliance in accordance with 7.1.6.3. The duct, sleeve or insulation enclosing the POCED shall be fitted in accordance with the manufacturer's instructions. This duct, sleeve or insulation shall be so dimensioned and arranged that it encloses a section of the POCED that is 350mm in length, as close to the appliance as the manufacturer's instructions allow.

Attach thermocouples junctions to the external surface of the duct, sleeve or insulation and then enclose the duct, sleeve or insulation with a 25 mm thick layer of insulation. Thermocouples shall be used in accordance with EN 60584-1:1995 with the limits of accuracy of the thermoelectric voltage used in accordance with Class 2 of EN 60584-2:1993.

The appliance is supplied with one of the reference gases indicated in 7.1.1 according to its category and adjusted in accordance with 7.1.3.2.1.

The test is carried out with the appliance operating at its nominal heat input. All measurements are taken when thermal equilibrium has been reached. It is recommended that for this test the appliance should be placed in a room where the ambient temperature is approximately 20 °C.

At the end of the test, check that the maximum temperature rise at the external surface of the duct, sleeve or insulation enclosing the POCED does not exceed the limit specified in 6.1.3.6.

7.3.4 Ignition, cross-lighting, flame stability

These tests are carried out with the appliance in the cold condition and at thermal equilibrium unless otherwise stated.

7.3.4.1 Ignition and cross-lighting

7.3.4.1.1 All appliances (still air conditions)

These tests are carried out with the appliance installed in accordance with 7.1.6.

7.3.4.1.1.1 Ignition of the burner(s)

The requirements of 6.1.4.1.1 are verified using the following series of tests:

Test 1

The appliance is supplied with the appropriate reference and limit gases (see Table 6) at the normal pressure in accordance with 7.1.4.

Under these supply conditions, it is checked that ignition of the main burner or the ignition burner occurs correctly and that ignition of the main burner by the ignition burner as well as cross-lighting of the various parts of the burner occurs correctly.

This test is repeated at the minimum heat input given by the controls, if ignition is possible under these conditions during normal operation in accordance with the manufacturer's instructions for use.

Test 2

Without altering the initial burner and ignition burner adjustments, the appliance is supplied with reference gas with the pressure at the appliance inlet reduced to the minimum pressure given in 7.1.4.

Under these supply conditions, it is checked that ignition of the main burner or the ignition burner occurs correctly and that ignition of the main burner by the ignition burner as well as cross-lighting of the various parts of the burner occurs correctly.

This test is repeated at the minimum heat input given by the controls, if ignition is possible under these conditions during normal operation in accordance with the manufacturer's instructions for use.

Test 3

Without altering the initial main burner or ignition burner adjustment, the appropriate flame lift and light-back limit gases are substituted successively for the reference gas and the pressure is reduced at the appliance inlet to the minimum pressure given in 7.1.4.

Under the supply conditions, it is checked that ignition of the main burner or the ignition burner occurs correctly and that ignition of the main burner by the ignition burner as well as cross-lighting of the various parts of the burner occurs correctly.

This test is repeated at the minimum heat input given by the controls, if ignition is possible under these conditions during normal operation in accordance with the manufacturer's instructions for use.

7.3.4.1.1.2 Ignition burner flame reduction

This test is carried out with the appliance installed in accordance with 7.1.6. The appliance is initially adjusted in accordance with the requirements of 7.1.3.2.1 and supplied with the appropriate reference gases (see Table 6) at nominal heat input.

The ignition burner gas rate is then reduced to the minimum required to hold open the gas supply to the main burner. The necessary reduction in the ignition burner gas rate may be achieved either by:

- the adjustment of the ignition burner gas rate adjuster, if this exists, or, if this is not possible;
- means of an adjuster inserted into the ignition burner gas supply for this purpose.

Correct ignition of the main burner by the ignition burner is then checked.

Where an ignition burner has several ports that are likely to become blocked, the test is carried out with all the ignition burner orifices blocked except for the one that produces the flame that heats the flame sensor.

It is checked that the requirements of 6.1.4.1.1 are satisfied.

7.3.4.1.2 Appliances where the start gas is taken from between the two main burner gas valves

The appliance is initially adjusted in accordance with the requirements of 7.1.3.2.1 and supplied with an appropriate reference gas (see Table 6) at the nominal heat input.

With the downstream automatic gas valve in the main gas line kept open artificially, ignite the appliance.

It is checked that the requirement of 6.1.4.1.2 is met.

7.3.4.1.3 Special conditions

7.3.4.1.3.1 Type B appliances

The appliance is supplied with an appropriate reference gas (see Table 6) at normal pressure. It is connected to a flue of the maximum diameter stated by the manufacturer and straight for a length of not less than 10 diameters immediately above the draught diverter. A down-draught of 3 m/s is applied through the flue using a suitable down-draught apparatus (see Figure 1).

A second test is carried out with the test flue blocked.

It is checked that the requirements of 6.1.4.1.3.1 and 6.1.4.2.2.1 are satisfied.

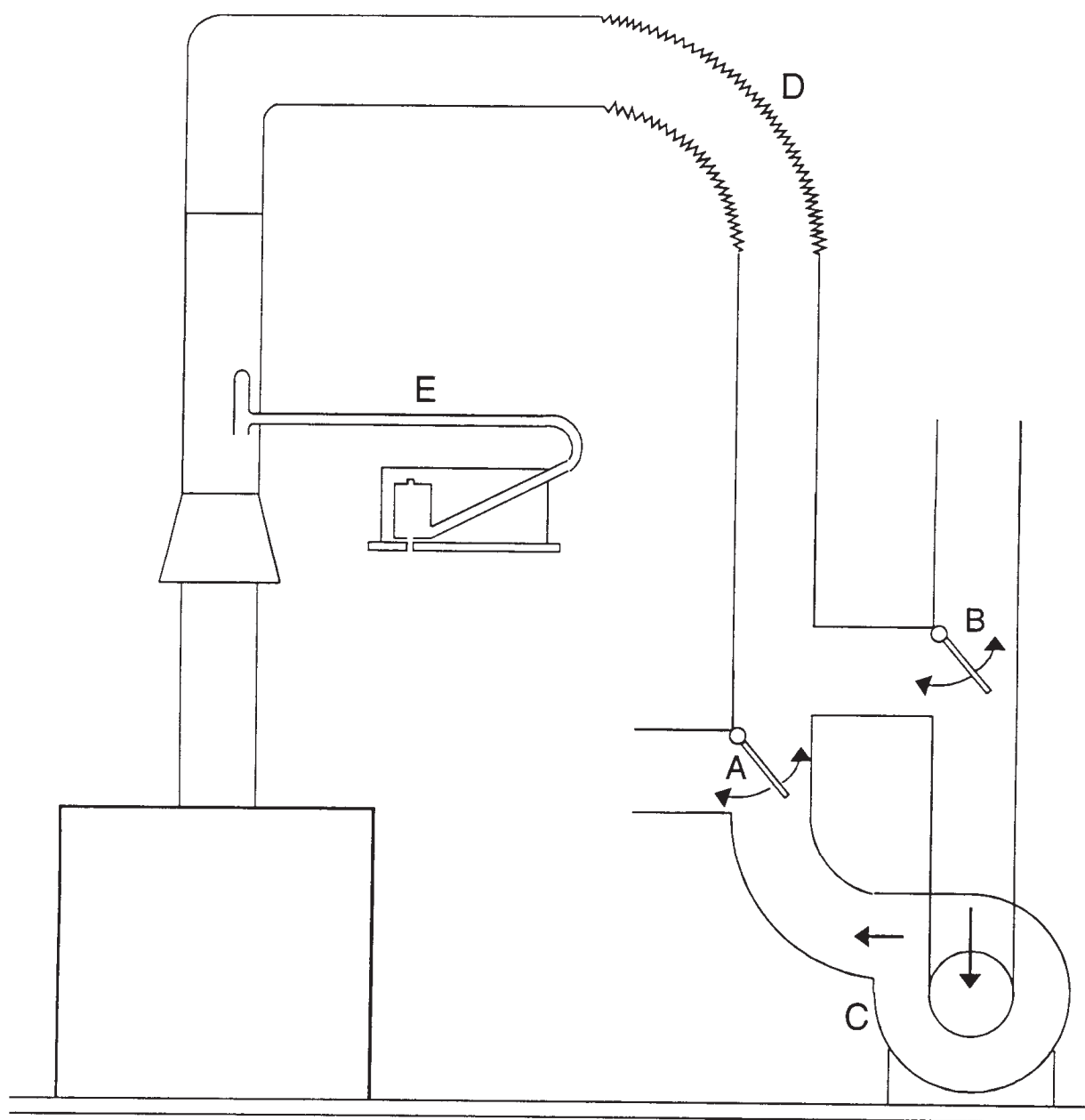

- Key**
- A Diverter valve to obtain either an updraught or downdraught
 - B Diverter valve to obtain either an updraught or downdraught
 - C Fan
 - D Flexible
 - E Velocity measurement position using a Pitot tube

Figure 1 — Test of an appliance under abnormal draught conditions

7.3.4.1.3.2 Type C₁₁ appliances

The appliance is installed on the apparatus described in Figure 2, with a flue length of 350 mm, unless the manufacturer's instructions indicate that a shorter length of flue can be used. In this case, the minimum length of flue specified by the manufacturer is used.

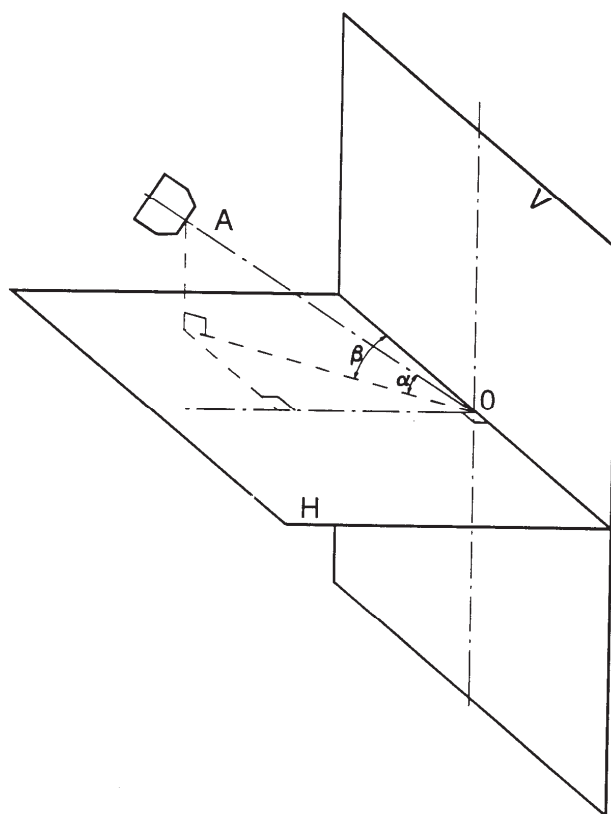

Key

- A Wind generator
- H Horizontal plane
- O Vertical plane
- α 0° (horizontal winds) + 30° and - 30°
- β 0° (glancing winds) 15°, 30°, 45°, 60°, 75°, 90° (perpendicular to the test wall)

When the terminal is not symmetrical, the tests are continued with incident angles of 105°, 120°, 135°, 150°, 165° and 180°.

Angle β may be varied either by modification of the position of the wind generator (fixed wall) or by rotation of the test wall about a central vertical axis.

The test wall consists of a strong vertical wall at least 1,8 m square with a removable panel at its centre. The terminal of the appliance is mounted so that its geometric centre is at the centre O of the test wall, and its projection from the wall is recommended by the manufacturer.

The characteristics of the wind generator and the distance from the test wall at which it is placed are chosen such that at the level of the test wall and after the central panel has been removed:

- the wind front is either approximately 90 cm square or a circular section with a diameter of 60 cm;
- wind speeds of 2,5 m/s, 5 m/s and 10 m/s can be obtained, with an accuracy of 10 %, over the whole of the wind front;
- the wind stream is essentially parallel and has no residual rotational movement.

When the central removable panel is not large enough to allow checking of these criteria, they are checked without the wall at a distance corresponding to the distance existing in practice between the wall and the wind generator discharge nozzle.

Figure 2 — Test apparatus for Type C₁₁ appliances

The appliance is supplied with an appropriate reference gas in accordance with Table 6, and adjusted to obtain the nominal heat input.

The requirements of 6.1.4.1.3.2 and 6.1.4.2.2.2 are checked using the following three series of tests:

Series 1

The appliance terminal is subjected to winds of different speeds in the following three planes (see also Figure 2):

- a) horizontal;
- b) ascending, at 30° to the horizontal;
- c) plunging, at 30° to the horizontal.

In each of these three planes, the incident angle of the wind is varied by 15° increments between 0° and 90° inclusive. If the terminal is not symmetrical about the vertical axis, the tests are carried out at 15° increments between 0° and 180° inclusive.

The tests are carried out at three wind speeds, 1 m/s, 2,5 m/s and 12,5 m/s.

Under each of these 63 conditions (117 if not symmetrical) a visual check is made of:

the ignition and stability of any ignition burner without the main burner alight;

- 1) the ignition of the main burner by any ignition burner;
- 2) the ignition and stability of the main burner at the nominal start gas rate;
- 3) the cross lighting of the main burner;
- 4) where applicable, the stability of any ignition burner (and the main burner when operating simultaneously).

These tests are carried out with the appliance at thermal equilibrium.

For each combination of wind speed and incident angle, the CO and CO₂ concentrations in the combustion products are noted.

Series 2

For each of the three incident planes, the three combinations of wind speed and incident angle that produce the lowest CO₂ concentrations in the combustion products are selected. For these nine combinations, it is checked that, with the appliance cold, it is possible to light the ignition burner, if any, and then the main burner by means of either the ignition burner or the device for direct ignition.

Series 3

The first and second series are repeated at the minimum heat input given by the controls if such operation is intended by the manufacturer.

7.3.4.1.3.3 Type C₂₁ and C₄₁ appliances (1st and 2nd family gases)

The appliance is installed on the apparatus shown in Figures 3 and 4.

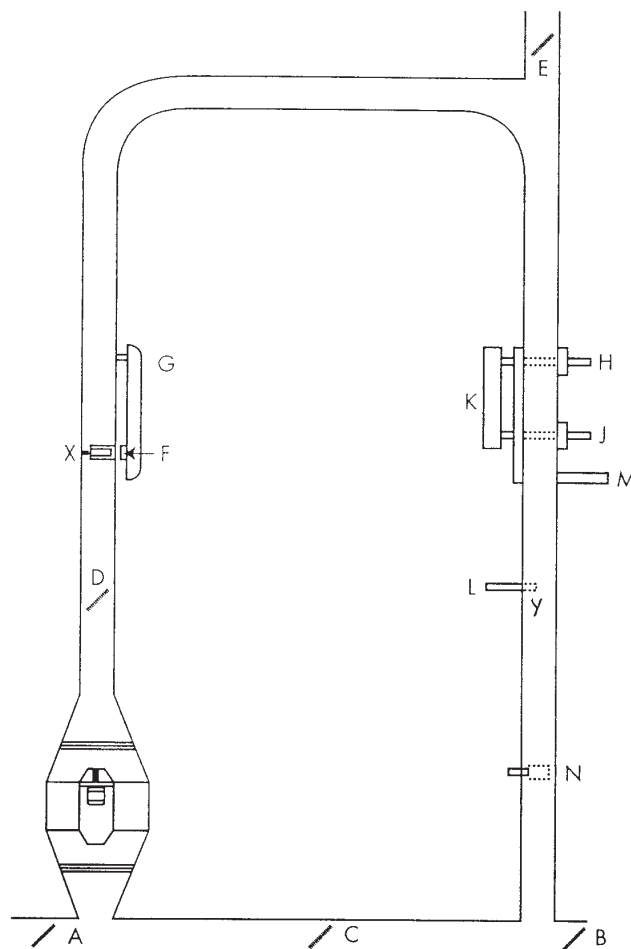

Key

- A Damper
- B Damper
- C Damper
- D Damper
- E Damper
- F Air control slide
- G Water heater
- H Thermocouple and sampling tube for connection to CO and CO₂ analyzers
- J Connection to CO and CO₂ analyzers for upflow vitiation tests
- K Test appliance
- L Temperature probe
- M Pressure probe
- N Two recording anemometers (interchangeable)
- X Reference position
- Y Reference position

Figure 3 — Test apparatus for Type C₂₁ and C₄₁ appliances (7.3.4.1.3.3)

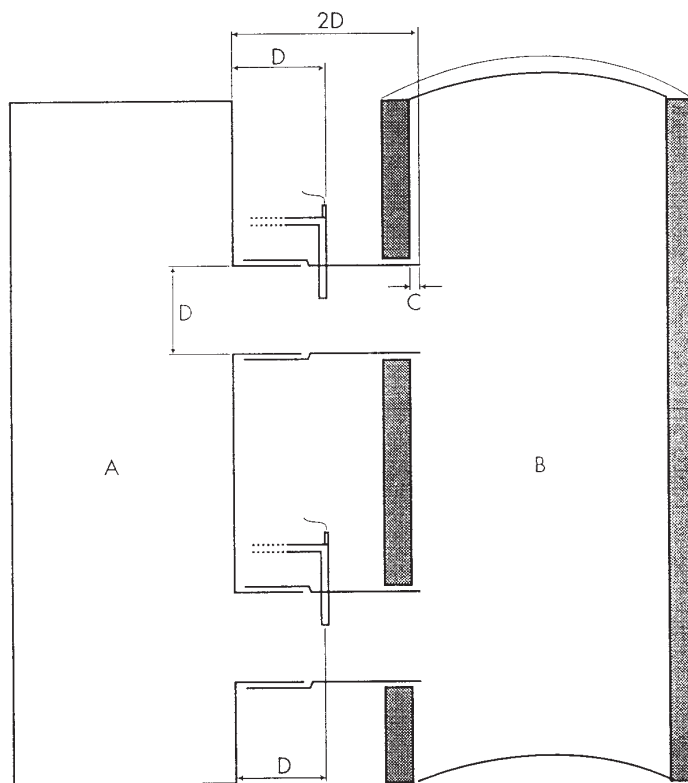

Key

- A Appliance
- B Combustion products duct
- C As specified in the manufacturer's instructions
- D Internal diameter (D) of the flue outlet

Figure 4 — Installation of a Type C₂₁ or C₄₁ appliance on the test duct (7.3.4.1.3.3)

It consists of a completely enclosed loop of 230 mm × 400 mm rectangular ducting through which air is circulated by a reversible bifurcated axial-flow fan. Velocity and pressure conditions are controlled by a series of single leaf dampers.

A water heater is supplied to provide an additional source of vitiation, its inlet being open to air and fitted with an air control slide F. The test appliance is mounted precisely according to the manufacturer's instructions on a long side of the duct with the appliance at least 2 m above the top of the horizontal base limb and with at least 1 m of vertical duct above the appliance. Access panels are provided on the back of the mounting panels to facilitate the fitting of the sample tubes and thermocouple.

The flow in the duct may be measured by a photoelectric type of vane anemometer which is placed 1 m above the top of the horizontal base limb. A calibration factor is used to convert the anemometer reading to mean flow as determined by pitot-static tube traverses.

NOTE 1 To cover the flow range of 0,3 m/s to 5 m/s, two interchangeable anemometers may be required. The apparatus is designed to be operated either as a closed or open circuit or in any condition intermediate between these extremes.

NOTE 2 In practice either the open circuit or an intermediate condition is required for the specified tests.

Operation of the apparatus to obtain the conditions of closed and open circuit is as follows:

a) Closed circuit

Dampers A, B, E and F are closed. Dampers C and D are used to control both flow and pressure conditions in the duct. For upflow in the test section, positive pressure may be produced with C fully open and flow controlled by D. Negative pressures may be produced with D fully open and the flow controlled by C.

NOTE 3 In practice it is necessary to adjust both dampers in turn to establish the required test condition.

When it is required under the upflow conditions of test to augment the degree of vitiation, the air slide at F is opened and the water heater is lit.

If the temperature in the duct at Y exceeds 65 °C, it has to be reduced by passing water through the finned heat exchanger introduced into the circuit at X.

NOTE 4 In practice, if the duct is made of metal, it is probable that this heat exchanger will not be required.

b) Open circuit

Dampers C, E and F are closed. Damper A is fully opened and dampers B and D are used to control both flow and pressure conditions in the duct. For upflow in the test section, a negative pressure has to exist but the magnitude for a given flow is determined by adjustment of B and D.

With dampers E and F shut, the fan is started and the rate and vitiation in the system controlled by means of dampers A, B, C and D to obtain the conditions given in Table 8 \pm 10 % using the appropriate reference gas at normal pressure.

Table 1 — Extent of vitiation

Family	Extent of vitiation % CO ₂	Duct air velocity m/s
1st	1	4,5
	2	2,0
2nd	0,75	4,5
	1,6	2,0

The proportion of fresh to recirculated air is controlled by combinations of adjustments to dampers A, B and C; damper D providing an overriding flow rate control.

It is checked that the requirements of 6.1.4.1.3.3 and 6.1.4.2.2.3 are satisfied.

7.3.4.1.3.4 Type C₃₁ appliances

The appliance is installed on the apparatus as shown in Figures 5 and 6, with the shortest length of combustion air and combustion products ducts declared by the manufacturer. The appliance is supplied with the appropriate reference gas in accordance with Table 6, and adjusted to obtain the nominal heat input.

All dimensions in millimetres

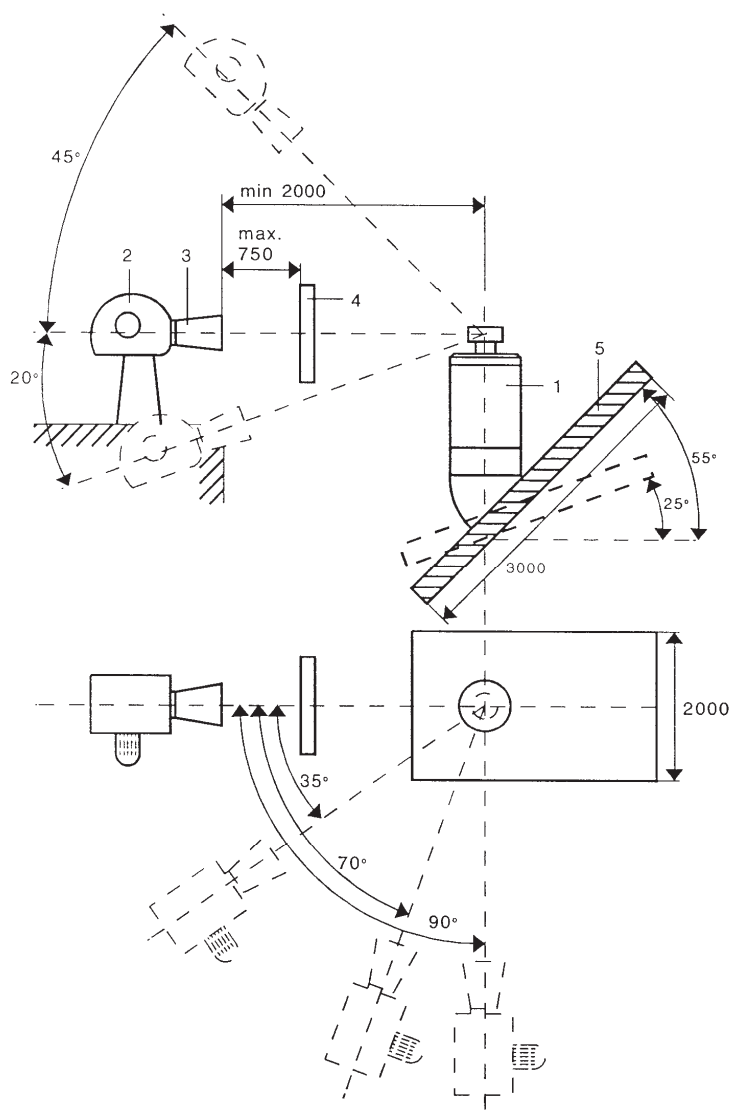

Key

- 1 Combustion air intake and flue outlet
- 2 Wind generator (shall be such that it can reproduce the wind speeds specified in 6.3.4.1.4.3 to within an accuracy of $\pm 10\%$ across the wind front)
- 3 Diffuser
- 4 Wind front (shall be sufficient to ensure that both the inlet and outlet of the terminal are covered)
- 5 Test surface

Figure 5 — Test apparatus for Type C₃₁ appliances - Angled roof

All dimensions in millimetres

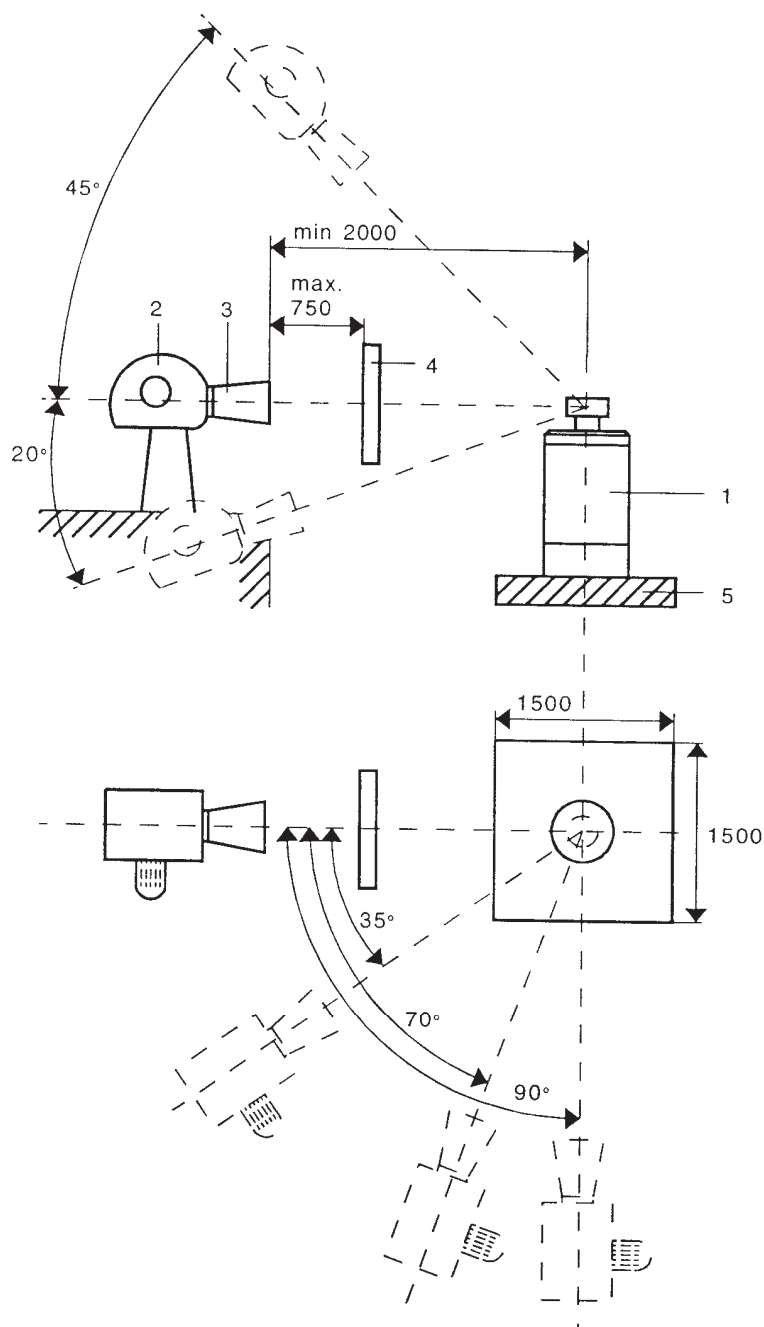

Key

- 1 Combustion air intake and flue outlet
- 2 Wind generator (shall be such that it can reproduce the wind speeds specified in 6.3.4.1.4.3 to within an accuracy of $\pm 10\%$ across the wind front)
- 3 Diffuser
- 4 Wind front (shall be sufficient to ensure that both the inlet and outlet of the terminal are covered)
- 5 Test surface

Figure 6 — Test apparatus for Type C₃₁ appliances - Flat roof

The requirements of 6.1.4.1.3.4 and 6.1.4.2.2.4 are checked using the following three series of tests:

Series 1

The appliance terminal is subjected to winds of different speeds in the following three planes:

- a) horizontal;
- b) ascending, at 20° to the horizontal;
- c) plunging, at 45° to the horizontal.

In each of these three planes, the incident angle of the wind is varied between 0° and 90° inclusive, with intermediate tests carried out at 35° and 70°. In addition, if the terminal is suitable for use on a sloping roof, the tests are repeated with the test surface angled at 25° and 55° (see Figure 5).

The tests are carried out at three wind speeds, 1 m/s, 2,5 m/s and 12,5 m/s.

Under each of these conditions a visual check is made of:

- 1) the ignition and stability of any ignition burner without the main burner alight;
- 2) the ignition of the main burner by any ignition burner;
- 3) the ignition and stability of the main burner at the nominal start-gas rate;
- 4) the cross-lighting of the main burner;
- 5) where applicable, the stability of any ignition burner (and the main burner when operating simultaneously).

These tests are carried out with the appliance at thermal equilibrium. For each of the three incident planes, the three combinations of wind speed and incident angle that produce the lowest CO₂ concentration in the combustion products are noted.

Series 2

For each of the nine combinations noted during series 1, it is checked that, with the appliance cold, it is possible to light the ignition burner, if any, and then the main burner by means of either the ignition burner or the device for direct ignition.

Series 3

The 1st and 2nd series are repeated at the minimum heat input given by the controls if such operation is intended by the manufacturer.

7.3.4.2 Flame stability

7.3.4.2.1 All appliances (still air conditions)

The requirements of 6.1.4.2.1 are checked using the following tests.

Test 1

Without altering the initial main burner or ignition burner adjustment, the appropriate light-back gas is substituted successively for the reference gas and the pressure is reduced at the appliance inlet to the minimum pressure given in 7.1.4.

Under these conditions it is checked that the flames are stable.

This test is then repeated at the minimum input given by the controls at which the appliance can operate normally in accordance with the manufacturer's instructions.

Test 2

Without altering the initial main burner or ignition burner adjustment, the appropriate flame lift and light-back limit gases are substituted successively for the reference gas and the pressure is increased at the appliance inlet to the maximum given in 7.1.4.

Under these conditions, it is checked that the flames are stable.

This test is then repeated at the minimum input given by the controls at which the appliance can operate normally in accordance with the manufacturer's instructions.

7.3.4.2.2 Special conditions (Type B appliances)

The appliance is supplied with the reference gas at normal pressure and is subjected at burner level to a wind stream of 2 m/s. The wind stream has a minimum diameter of 0,5 m, but covers at least the width of the appliance and is essentially parallel (speed uniform to within $\pm 20\%$).

The axis of the wind stream is in a horizontal plane and is moved through one or more (at the discretion of the laboratory) angles of incidence within a semi-circle in front of the appliance, the centre of the semi-circle passing through the plane of symmetry of the appliance.

The test is carried out with the main burner and any ignition burner alight together and, if appropriate, with only the ignition burner alight. Any lighting door remains closed during the test. The test is repeated at the minimum input given by the controls if such operation is intended by the manufacturer. During the test, precautions should be taken to screen the draught diverter from the effects of the 2 m/s wind stream.

It is checked if the requirements of 6.1.4.2.2.1 are met.

7.3.5 Combustion

7.3.5.1 Test installation

Unless otherwise specified hereafter, Type B₁₁ appliances are installed in accordance with 7.1.6.2.1 and Type B₄₁ appliances are installed in accordance with 7.1.6.2.2.

Unless otherwise specified hereafter, Type C₁₁ appliances are installed in accordance with 7.1.5.2.3; with the exception that the flue shall be of the maximum length specified by the manufacturer.

Unless otherwise specified hereafter, Type C₂₁ and Type C₄₁ appliances are installed in accordance with 7.1.5.2.4.

Unless otherwise specified hereafter, Type C₃₁ appliances are installed in accordance with 7.1.5.2.5; with the addition that the tests are carried out twice, one time with the shortest and one time with the longest possible lengths of the combustion products duct and combustion air duct as stated and delivered by the manufacturer.

7.3.5.2 Test procedure

The appliance is initially adjusted to the nominal heat input in accordance with 7.1.3.2.

The products of combustion shall be collected in such a manner as to ensure a representative sample, using a suitable sampling probe (see Figures 7, 8, 9 and 10 as appropriate).

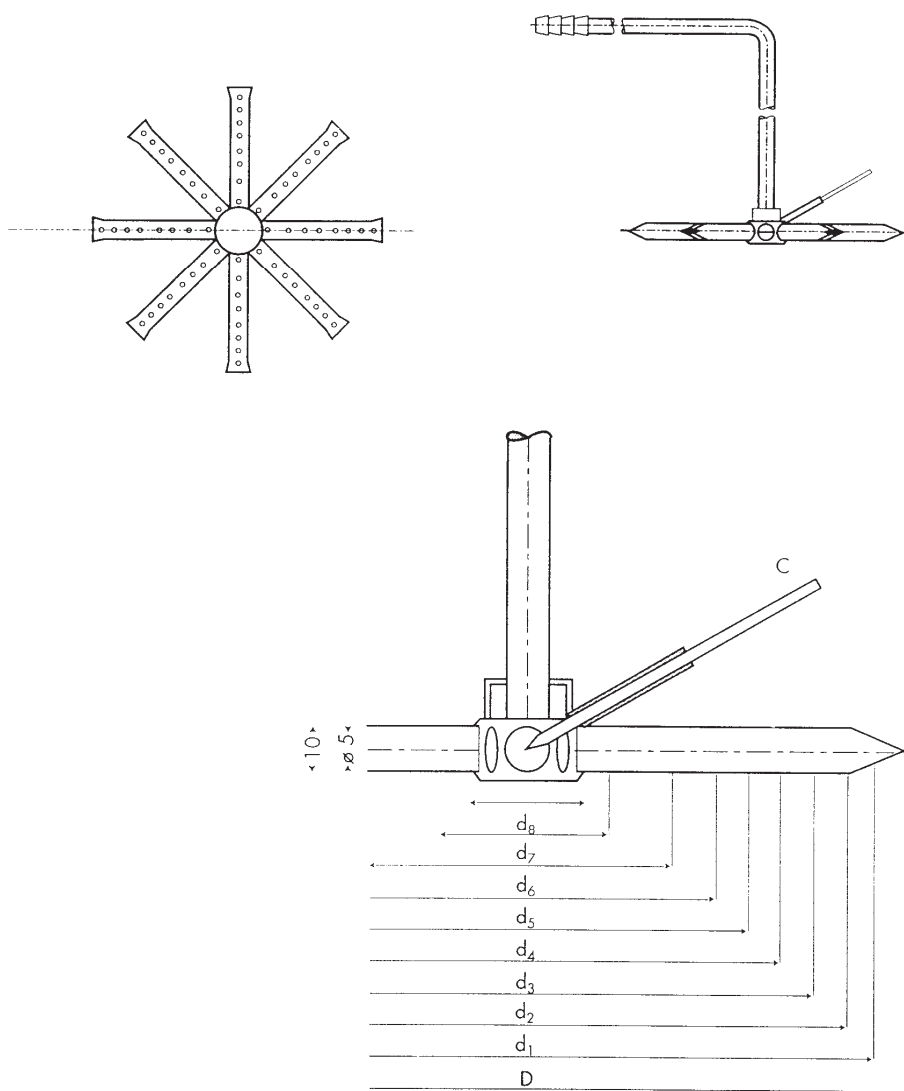

D (nominal)	$d_1 = 0,97 D$	$d_2 = 0,90 D$	$d_3 = 0,83 D$	$d_4 = 0,75 D$	$d_5 = 0,66 D$	$d_6 = 0,56 D$	$d_7 = 0,43 D$	$d_8 = 0,25 D$
100	97	90	83	75	66	56	43	25
110	107	99	91	82	74	62	47	27
120	116	108	100	90	79	67	52	30
130	126	117	108	98	86	73	56	33
150	145	135	125	113	99	84	65	38
180	175	162	149	135	119	101	77	45
200	194	180	166	150	132	112	86	50
250	242	225	208	188	165	140	108	63
300	291	270	249	225	198	168	129	75
400	388	360	332	300	264	224	173	100
500	485	450	415	375	330	280	216	125

Figure 7 — Sampling probe for Type B₁₁ and C₃₁ appliances with an outlet diameter of 100 mm or more

Dimensions in millimetres unless otherwise stated

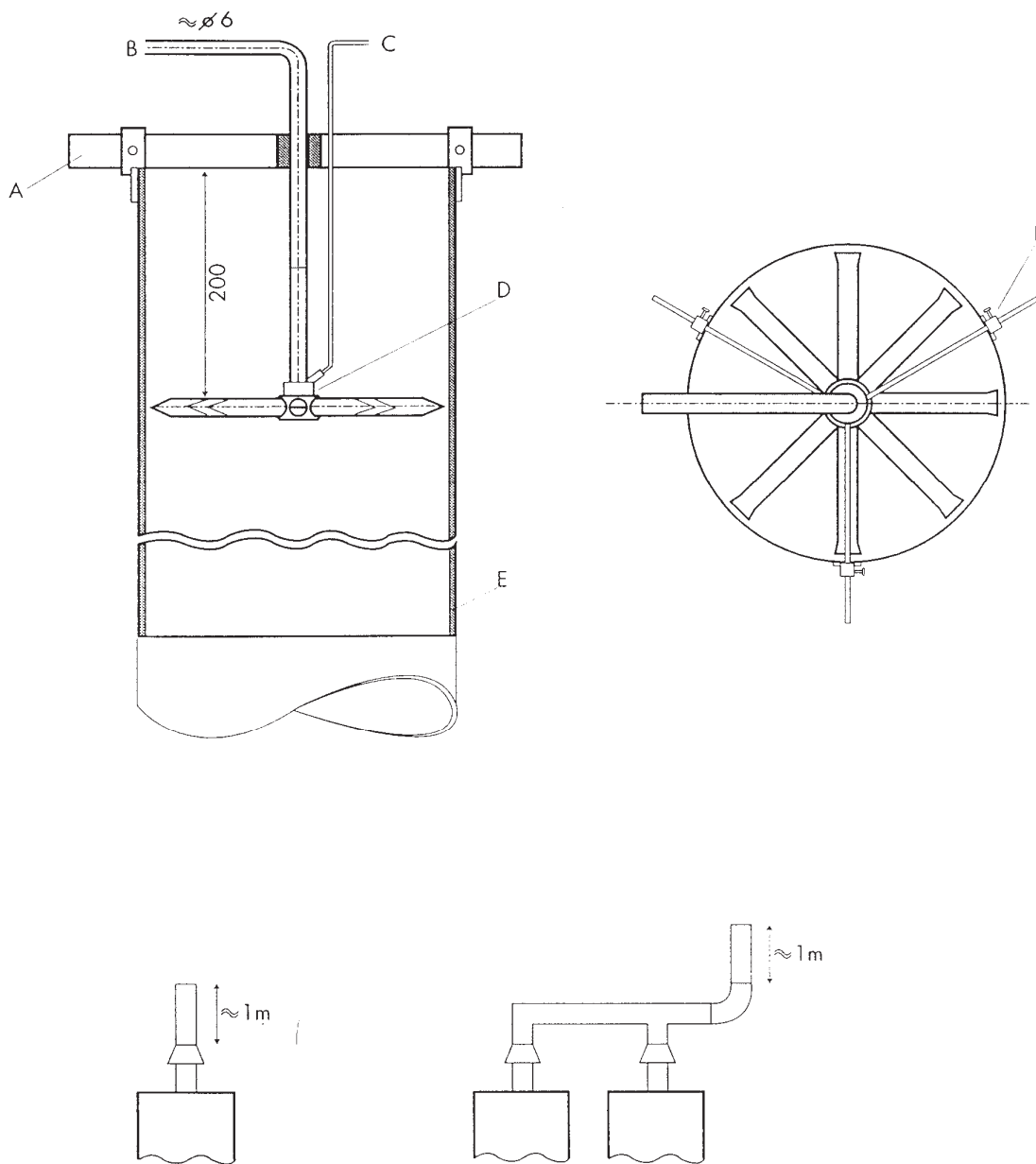

Key

- A Support
- B To sampling pump
- C To pyrometer
- D Sampling probe (see Figure 7)
- E Sheet metal
- F Adjustable spacing device

Figure 8 — Location of the sampling probe for Type B₁₁ and C₃₁ appliances with an outlet diameter of 100 mm or more

Dimensions in millimetres

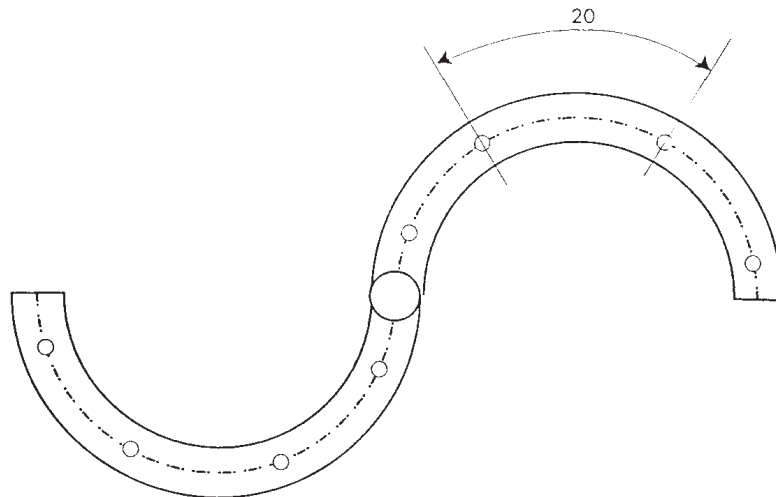
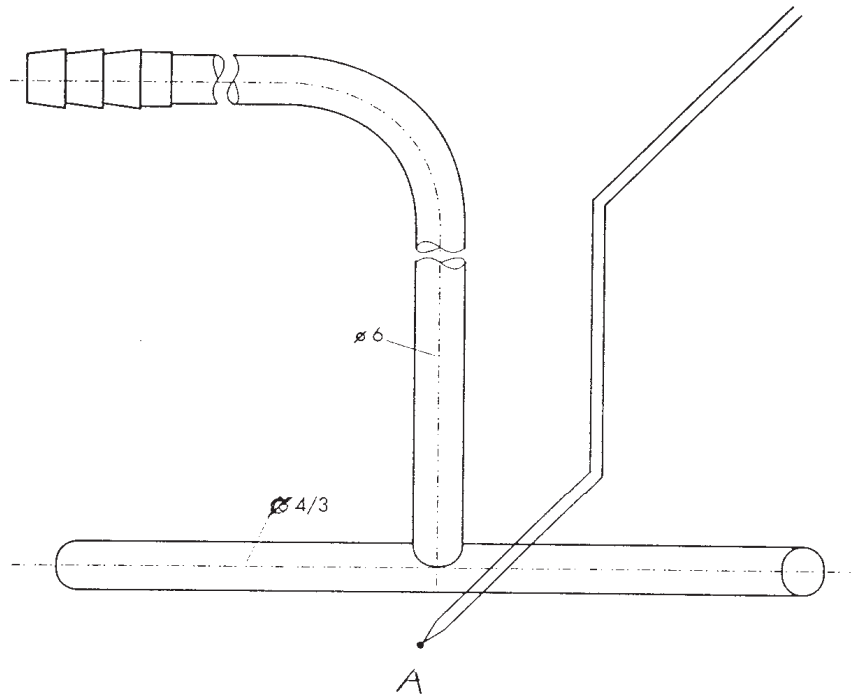

Key
A Thermocouple

Figure 9 — Sampling probe for Type B₁₁ and C₃₁ appliances with an outlet diameter of less than 100 mm

Dimensions in millimetres

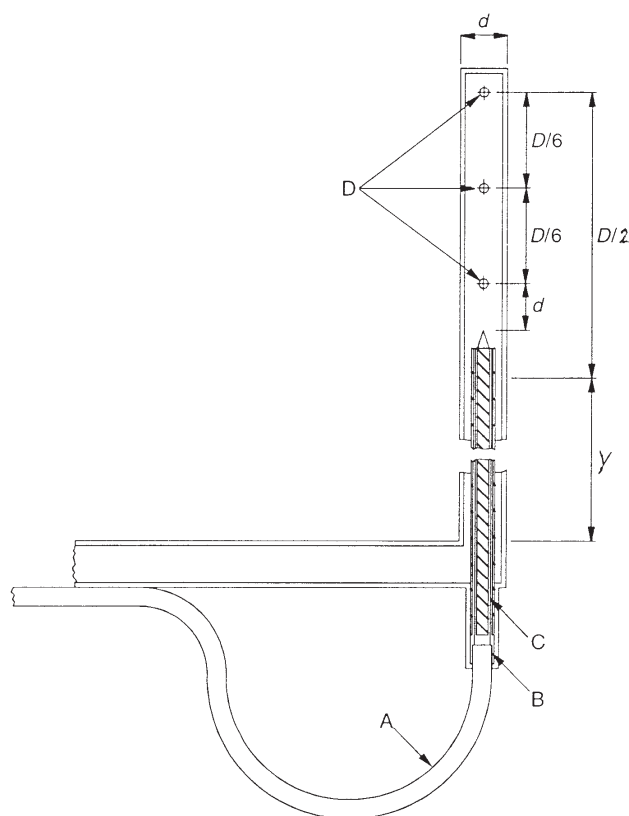

NOTE 1 The material is stainless steel with a polished finish.

NOTE 2 Dimension Y should be chosen according to the diameter of the air inlet duct and its insulation.

NOTE 3 Dimensions for 6 mm diameter probe (suitable for product outlet ducts of diameter (D) over 75 mm) are:

- a) outside diameter of probe (d) - 6 mm;
- b) wall thickness - 0,6 mm;
- c) diameter of sampling holes (x) - 1,0 mm;
- d) twin bore ceramic sleeve - $\text{Ø } 3 \text{ mm} \times 0,5 \text{ mm}$ bore;
- e) thermocouple wire - $\text{Ø } 0,2 \text{ mm}$.

For products outlet ducts less than 75 mm diameter a smaller probe should be used with d and x chosen such that:

- 1) the area obstructed by the probe is less than 5 % of the cross section of the duct;
- 2) the total area of the sampling holes is less than three-quarters of the cross section of the probe.

Key

- A Chromel/Alumel thermocouple wire
- B Insulating cement
- C Twin bore ceramic sleeve
- D Sampling holes

Figure 10 — Sampling probe for Type C₁₁, C₂₁ and C₄₁ appliances

The concentrations of carbon monoxide, CO, carbon dioxide, CO₂, and oxygen, O₂, where appropriate, are measured by a method accurate to within ± 6 % of the reading.

For all tests, the sample shall be taken when the appliance has reached thermal equilibrium whilst operating under the specified conditions.

The CO concentration of the dry, air-free products of combustion (neutral combustion) is given by Equation (8).

$$V_{\text{CO,N}} = V_{\text{CO}_2,\text{N}} \times \frac{V_{\text{CO}_2,\text{M}}}{V_{\text{CO}_2,\text{M}}} \quad (8)$$

where

$V_{\text{CO,N}}$ is the carbon monoxide concentration of the dry air-free products of combustion (%);

$V_{\text{CO}_2,\text{N}}$ the calculated carbon dioxide content of the dry air-free products of combustion (%);

$V_{\text{CO}_2,\text{M}}$ and $V_{\text{CO}_2,\text{M}}$ are the carbon monoxide and carbon dioxide concentrations measured in the sample during the combustion test (%).

The values of $V_{\text{CO}_2,\text{N}}$ (neutral combustion) are given for the test gases in Table 7.

Table 9 — $V_{\text{CO}_2,\text{N}}$ values

Gas designation	G 110	G 20	G 21	G 25	G 26	G 30	G 31
$V_{\text{CO}_2,\text{N}}$	7,6	11,7	12,2	11,5	11,8	14,0	13,7

The carbon monoxide concentration of the dry, air-free combustion products ($V_{\text{CO,N}}$) may also be calculated using Equation (9).

$$V_{\text{CO,N}} = \frac{21}{21 - V_{\text{O}_2,\text{M}}} \times V_{\text{CO}_2,\text{M}} \quad (9)$$

where

$V_{\text{CO}_2,\text{M}}$ is the carbon monoxide concentration (%) of the dry, air free combustion products;

$V_{\text{O}_2,\text{M}}$ is the oxygen concentration (%) measured in the sample;

$V_{\text{CO}_2,\text{M}}$ is the carbon monoxide concentration (%) measured in the sample.

The use of Equation (9) is recommended where it gives greater accuracy than the formula based on the CO₂ concentration (see Equation (8)).

7.3.5.3 All appliances (still air conditions)

The requirements of 6.1.5.1 are checked using the following tests, carried out under still air conditions.

Test 1 Without altering the initial burner adjustment the appliance is supplied with the appropriate reference gases (see Table 6) according to its category and the pressure at the appliance inlet increased to the maximum pressure given in 7.1.4.

Test 2 Without altering the initial burner adjustment, the appliance is supplied with the appropriate reference gases (see Table 6) according to its category with the pressure at the appliance inlet reduced to 70 % of the normal pressure or the minimum pressure given in 7.1.4, whichever is the lower.

Test 3 Without altering the initial burner adjustment, the appropriate incomplete combustion limit gases are substituted successively for the reference gas and the pressure at the appliance inlet increased to the maximum pressure given in 7.1.4. It is checked that the requirements of 6.1.5.1 are assured.

Test 4 Without altering the initial burner adjustment, the appliance is supplied with the appropriate reference gases (see Table 6) according to its category and with the normal gas pressure at the appliance inlet.

The test is carried out with the appliance supplied with electricity at a voltage of 85 % of the minimum and then at a voltage of 110 % of the maximum of the voltage range stated by the manufacturer.

7.3.5.4 Special conditions

7.3.5.4.1 Type B appliances

Without altering the initial burner adjustment, the appliance is supplied with the appropriate reference gases (see Table 6) according to its category and operated at the nominal heat input.

A first test is carried out with the flue blocked.

A second test is carried out by applying a continuous down-draught of 3 m/s and 1 m/s within the test flue using a suitable down-draught apparatus (see Figure 1).

The combustion products are collected in such a manner as to ensure a representative sample using a suitable device located within the draught diverter.

It is checked that the requirements of 6.1.5.2.1 are satisfied.

7.3.5.4.2 Type C₁₁ appliances

The combustion products are sampled under the conditions of test given in 7.3.4.1.3.2. The average of the nine highest CO values noted in 7.3.4.1.3.2 is determined and its compliance with the requirement of 6.1.5.2.2 is verified.

7.3.5.4.3 Type C₂₁ and C₄₁ appliances (1st and 2nd family gases)

The appliance is installed and operated on the test apparatus described in 7.3.4.1.3.3.

After the appliance has been alight for 15 min, samples of the inlet air and products of combustion are taken and analyzed. For Type C₂₁ appliances, the CO percentage is taken to be the difference between the CO percentage in the combustion products and the percentage of CO in the combustion air inlet.

It is checked that the requirements of 6.1.5.2.3 are satisfied.

7.3.5.4.4 Type C₃₁ appliances

The combustion products are sampled under the conditions of test given in 7.3.4.1.3.4. The average of the nine highest CO values noted in 7.3.4.1.3.4 is determined and its compliance with the requirement of 6.1.5.2.4 is verified.

7.3.5.5 Other pollutants

7.3.5.5.1 General

The appliance is installed as specified in 7.3.5.1

For appliances intended to use second and third family gases, the tests are carried out with reference gas G 20. For appliances intended to use only G 25 as the reference gas, the tests are carried out with G 25. For appliances intended to use only third family gases, the tests are carried out with reference gas G 30. For appliances intended to use propane only, the tests are carried out with reference gas G 31.

The appliance is adjusted to its nominal heat input and, where appropriate, to other heat inputs provided by the controls.

Then NO_x measurements are carried out when the appliance is at thermal equilibrium, conforming with details as given in CR 1404.

The reference conditions for the combustion air are:

- a) temperature 20 °C;
- b) humidity: 10g H₂O/kg air.

If the test conditions are different from these reference conditions, it will be necessary to correct the NO_x values using Equation (10):

$$NO_{x,0} = NO_{x,m} + \frac{0,02NO_{x,m} - 0,34}{1 - 0,02(h_m - 10)}(h_m - 10) + 0,85(20 - T_m) \quad (10)$$

where

NO_{x,0} is the value of NO_x corrected to the reference conditions expressed in mg/kWh;

NO_{x,m} is the measured at h_m and T_m in mg/kWh in the range 50 mg/kWh to 300 mg/kWh;

h_m is the humidity during the measurement of NO_{x,m} in g/kg in the range 5 g/kg to 15 g/kg;

T_m is the ambient temperature during the measurement of NO_{x,m} in °C in the range 15 °C to 25 °C.

The measured NO_x values are weighted in accordance with 7.3.5.5.2. It is checked that the weighted NO_x value does not exceed the limit stated in 6.1.5.3.

For the calculation of conversions of NO_x, see Annex G

7.3.5.5.2 Weighting

7.3.5.5.2.1 General

The measured NO_x values are weighted using Equations (11), (12) and (13) which take into account the efficiency of the appliance, its heat capacity and its usage characteristics.

7.3.5.5.2.2 On/Off appliances

$$E_{Q_n} = \frac{9\eta_{ref}}{10\eta_{Q_n}} \quad (11)$$

7.3.5.5.2.3 High/low appliances

$$0,5E_{Q_n} \cdot \frac{9\eta_{ref}}{10\eta_{Q_n}} + 0,5E_{Q_{min}} \cdot \frac{9\eta_{ref}}{10\eta_{Q_{min}}} \quad (12)$$

7.3.5.5.2.4 Modulating appliances

$$0,5E_{Q_n} \cdot \frac{9\eta_{ref}}{10\eta_{Q_n}} + 0,8E_{Q_{min}} \cdot \frac{9\eta_{ref}}{10\eta_{Q_{min}}} \quad (13)$$

where

E_{Q_n} is the emission figure at the nominal heat input;

$E_{Q_{min}}$ is the emission figure at the minimum heat input;

η_{ref} is the reference efficiency (i.e. the applicable efficiency requirement stated in 6.2);

η_{Q_n} is the efficiency at nominal heat input;

η_{min} is the efficiency at minimum heat input;

η_{60} is the efficiency at 60 % of the nominal heat input.

NOTE Also see 6.2, where Q_{min} is understood to be any heat input lower than the nominal heat input, and for which both the efficiency and the NO_x emission figure are measured.

7.3.6 Overheat protection

The appliance is installed as described in 7.1.6.

For ducted appliances the air outlet spigot is fitted with a duct with a length of 1 m, having the same shape as the outlet. At the end of the duct, two sliding covers are mounted to adjust the free outlet opening. The sensors for measuring the air temperature and the static air pressure test point are placed 100 mm before the outlet end of the test duct (see Figure 11). This test duct shall be supplied by the manufacturer.

Dimensions in millimetres

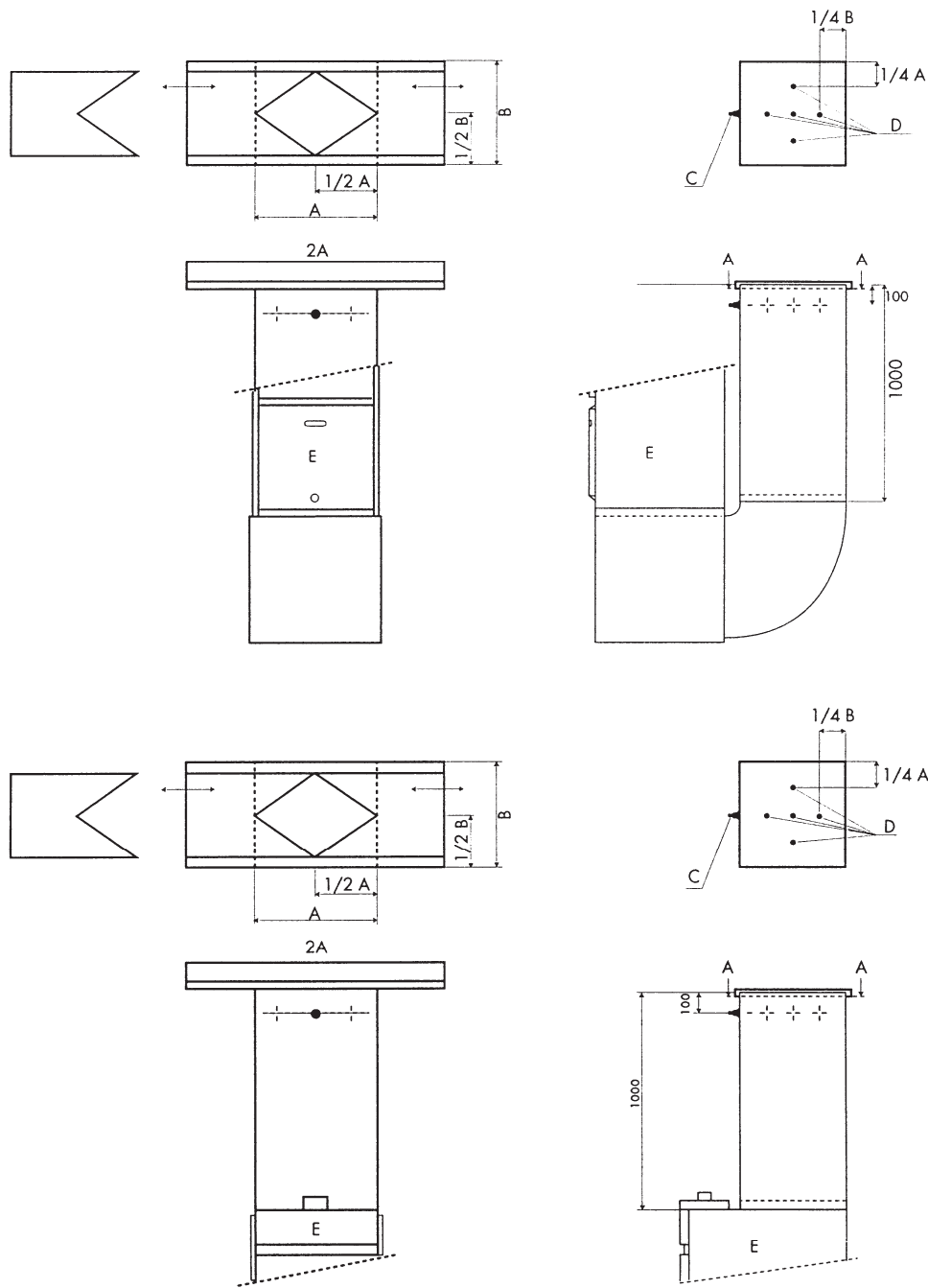

- Key**
- A x B Outlet dimensions
 - C Static air pressure
 - D Air temperature on frame
 - E Appliance

Figure 11 — Position of sensors for overheat protection test

Ductless appliances meant for single or multiple outlets shall be supplied by the manufacturer with the outlet(s) fitted. The outlet(s) is/are part of the appliance and shall therefore be delivered with the appliance. Louvres may be adjustable. The sensors for measuring the air temperature are placed directly outside each outlet and in the plane of that outlet, whereas the static air pressure test point is in the centre of the appliance outlet and at least 100 mm from any louver.

Test 1

The appliance is operated from the nominal condition or an air temperature of at least 20 K below the expected response temperature of the overheat limit device or overheat cut-off device, using an appropriate reference gas as specified in Table 4. The overheat protection shall not operate.

Range-rated appliances are operated at the maximum heat input and at the minimum heat input as specified by the manufacturer.

For ducted appliances, the airflow is progressively reduced by sliding the covers on the duct until the overheat protection operates to stop the gas supply to the main burner. The temperature rise during this test shall not exceed 3 K per min.

For ductless appliances, the airflow is progressively reduced by closing the louvres until the overheat protection operates to stop the gas supply to the main burner. In case of multiple outlets the effect of closing each outlet is determined. The temperature rise during this test shall not exceed 3 K per min.

The appliance is cycled on the overheat control for sufficient time to ensure that the worst conditions have been reached.

It is checked that the relevant requirements of 6.1.6 and 6.1.3.5 are satisfied.

Test 2

The air distribution fan and the air temperature controls other than meant for overheat protection, are rendered inoperative.

The appliance is operated from the cold condition at the nominal heat input using an appropriate reference gas as specified in Table 4. However, range-rated appliances are operated at the maximum heat input specified by the manufacturer.

In case of an autoreset type of control the appliance is cycled on the overheat control for sufficient time to ensure that the worst condition has been reached.

In case of a manual reset mechanism, this is operated after the first cut-out and after each minute of this and every subsequent cooling period until the control permits reheat.

It is checked that the relevant requirements of 6.1.6 are satisfied.

7.3.7 Heat exchanger thermal cycling

The appliance is installed as described in 7.1.6. The test is carried out at 1,1 times the nominal input.

The heat exchanger elements are examined carefully. Manufacturing abnormalities such as tool damage, poor welding, careless assembly, etc. are identified as far as possible and are not considered in the assessment of the test.

Any necessary action shall be taken to safeguard other components that may be adversely affected during the test and to avoid abnormal deleterious effects on the heat exchanger.

The appliance is installed on a test rig equipped with inlet and outlet air ducts sized to suit the output rating of the appliance.

The air temperature control and the overheat control are disconnected and the control system is modified by the introduction of a timing device to enable the appliance to cycle for 3,5 min with the gas supply on and the fan off followed by 3,5 min with the gas supply off and the fan on.

Inspect the heat exchanger for failure at least every 2 000 cycles until 10 000 cycles have been completed.

When inspecting the heat exchanger, the appliance is operated with both fan and gas on together and it is checked that the burner operates correctly. The heat exchanger is visually examined in situ using a mirror and inspection lamp.

On completion of 10 000 cycles, the heat exchanger is carefully dismantled from the appliance and examined for splits, openings and perforations. Surface deteriorations or defects shall be ignored. It is checked that the requirements of 6.1.7 are satisfied.

NOTE If it can be shown that either the physical form of the heat exchanger, or the type of control adopted, make such a test inappropriate, an equivalent test may be devised and agreed by negotiation between the manufacturer and the notified body.

7.3.8 Atmosphere sensing device (Type B_{11AS} and B_{41AS})

7.3.8.1 Test room

The appliance is installed in accordance with the manufacturer's instructions other than for the ventilation requirements and with 1 m of flue fitted on or adjacent to the narrowest wall of a sealed room and adjusted to the nominal heat input using the appropriate reference gases.

Minimum room dimensions are:

- a) length 3,5 m;
- b) width 2,0 m;
- c) height 2,5 m;
- d) volume 17,5 m³

Alternative room geometries may be used by agreement between the manufacturer and the notified body.

The soundness of the room shall be such that, after a homogeneous room concentration of 4 % ± 0,2 % CO₂ has been established, it shall not have decreased by more than 0,15 % after a 1 h period.

The room is designed so that:

- 1) the operator can, at any time, observe the appliance in operation;
- 2) the atmosphere in the room is maintained as a homogeneous mixture;
- 3) the temperature at the centre of the room is maintained between 15 °C and 35 °C.

7.3.8.2 Test method

Using the appropriate reference gas, the appliance is operated at its maximum heat input. Return air and delivered air shall be sealed from the air in the test room. If the appliance is meant for ductless operation, the manufacturer shall provide a suitable duct. Sampling of the room atmosphere for carbon monoxide shall be carried out in a horizontal plane 1,5 m above floor level.

7.3.8.2.1 Normal operating conditions

The appliance is operated at its maximum heat input with the door of the room open and the flue functioning normally to the outside of the room for 30 min, then it is checked that requirement 6.1.8.1 is met.

7.3.8.2.2 Sealed room conditions

At the end of the 30 min period of operation, the flue is capped, the room sealed and the atmosphere in the room monitored continuously for its CO concentration until the burner is extinguished, then for a further 5 min to ensure stability of reading. It is checked that the requirement of 6.1.8.2 is met.

7.3.9 Combustion products discharge safety system (Type B_{11BS} and B_{41BS})

7.3.9.1 Temperature resistance

The appliance is fitted with a flue pipe as defined in 7.3.9.2. Using the appropriate reference gas, the appliance is adjusted to the nominal heat input or to the maximum heat input in case of a range-rated appliance. The delivery air flow is set to its minimum.

The combustion products discharge safety system is deliberately disabled without removing any of its components.

The flue outlet is then covered completely and the appliance is allowed to operate in this condition for 4 h. After this period, a check is made that the requirements of 6.1.9.1 are satisfied.

7.3.9.2 Switching function

The requirements of 6.1.9.2 shall be met when the combustion products discharge safety system is tested in accordance with 7.3.9.3, 7.3.9.4, and 7.3.9.5. Except where stated otherwise, testing shall be carried out with a standard flue pipe (after draught diverter) with a length of 0,5 m and a diameter equal to that of the appliance flue connection.

7.3.9.3 Response time at zero flue draught

The appliance is fitted with a flue pipe as defined in 7.3.9.2. Using the appropriate reference gas, the appliance is adjusted to the nominal heat input or to the maximum heat input in case of a range-rated appliance. The delivery air flow is set to its maximum.

The flue outlet is then covered completely and the time elapsing between the covering of the duct and the operation of the combustion products discharge safety system is measured.

In case of a range-rated appliance or an appliance with variable heat input, this test is also carried out at 50 % of the nominal heat input, respectively of the maximum of the heat input range.

It is checked that the requirements of 6.1.9.3 are satisfied.

7.3.9.4 Prevention of unintentional shut-down

The appliance is installed with a flue pipe in accordance with 7.3.9.2, and set at its nominal heat input or at the maximum of the heat input range in case of a range-rated appliance, using an appropriate reference gas. The delivery air flow is set to its nominal rate as stated by the manufacturer.

The appliance is operated under these conditions for 30 min. It is then checked that the requirements of 6.1.9.4 are satisfied.

7.3.9.5 Operation at partial leakage or reduced draught

The appliance is set at its nominal heat input, or at the maximum of the heat input range in case of a range-rated appliance, using an appropriate reference gas. The delivery air flow is set to its nominal rate as stated by the manufacturer.

A telescopic flue pipe adjusted to the minimum flue height stated by the manufacturer and with a diameter equal to that of the appliance flue connection is fitted on the appliance, instead of the flue pipe mentioned in 7.3.9.2.

With the pipe adjusted to this height, the appliance is operated until the state of thermal equilibrium is reached.

Then the flue pipe is adjusted such that spillage of flue gas from the draught diverter just fails to occur. This is checked with a suitable means, e.g. a dewpoint mirror, at the draught diverter.

If the combustion products discharge safety system shuts down the appliance before the point is reached at which leakage of flue gas just fails to occur, the requirements of 6.1.9.5 are satisfied and further testing is not required.

If this is not the case, the test is continued as follows:

The outlet of the adjusted flue pipe is covered by an annulus with an aperture having an area of 35 % of the nominal area of the flue duct (see Figure 12). The time elapsing between the fitting of the annulus and the operation of combustion products discharge safety system is measured and it is checked that the requirements of 6.1.9.5 are satisfied.

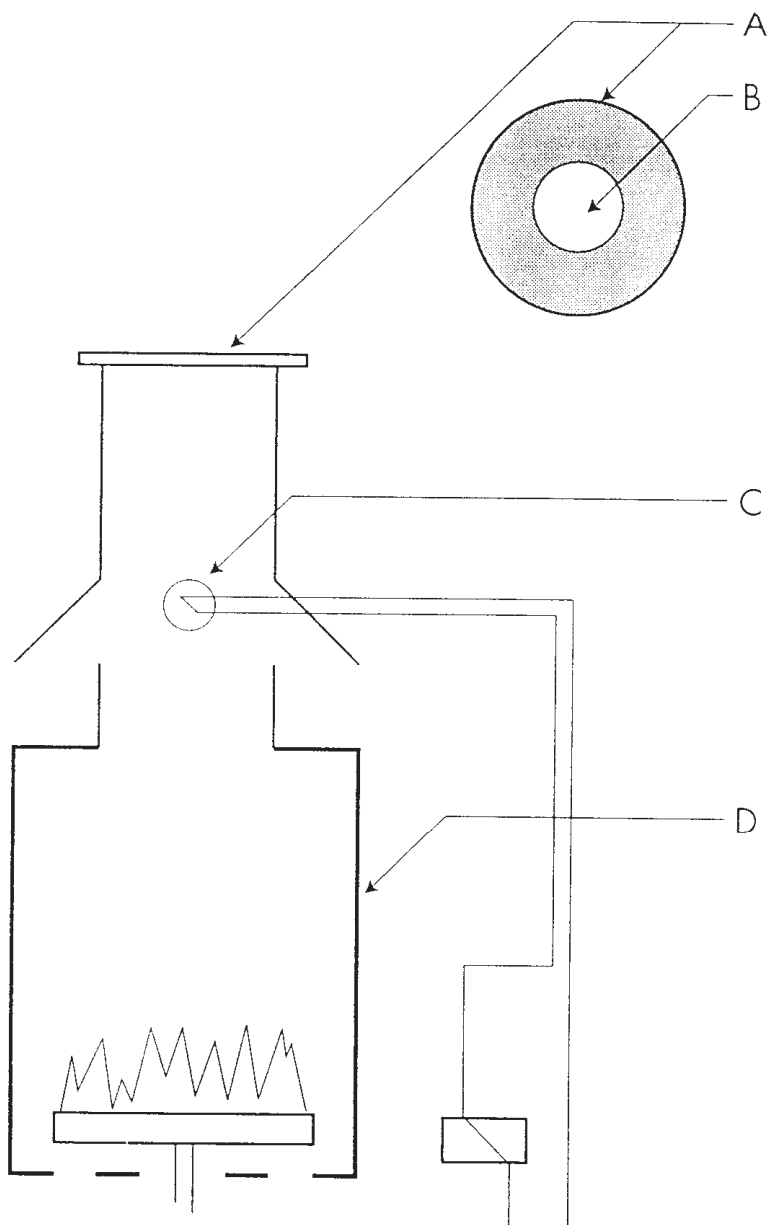

Key

- A Annulus
- B Area = 35 % of nominal area of flue duct
- C Combustion products discharge safety system sensor
- D Appliance

Figure 12 — Test apparatus for combustion products discharge safety device

7.3.9.6 Behaviour in the event of a sensor defect

With the appliance operating at nominal heat input under normal operating conditions, the sensor wiring is disconnected, and it is checked that the requirements of 6.1.9.6 are satisfied.

7.4 Efficiency

7.4.1 General conditions of test

7.4.1.1 Principle of method

The thermal efficiency is determined by the flue loss method from measurements of CO₂ (or O₂) concentration and the temperature of the products of combustion.

7.4.1.2 Test room

The room shall be adequately ventilated but free from draughts likely to affect the performance of the appliance. The room temperature shall be in accordance with 7.1.6.1 and during the course of a test, it shall not vary by more than 2 K.

7.4.1.3 Preparation of appliance

The appliance is installed in accordance with 7.1.6 and operated, in accordance with the manufacturer's instructions, with reference gas (see Table 6), except that Type B appliances are installed using the widest test flue stated by the manufacturer and that Type C₃₁ appliances are installed on combustion air and combustion products ducts of the shortest length declared by the manufacturer.

7.4.2 Test conditions

The appliance is supplied with typical distributed gas(es) or the reference test gas(es) corresponding to its category and operated within $\pm 2\%$ of the specified heat input(s) against the maximum static pressure in the warm air delivery duct recommended by the manufacturer. The fan speed is such that the temperature rise of the delivered air is according to the manufacturer's specifications ± 5 K when the appliance is operated at the maximum rated heat input.

The CO₂ (or, where appropriate, O₂) concentration and the temperature of the combustion products are measured by means of a probe as defined, incorporating a temperature measuring device, located in the secondary flue or combustion products duct, as appropriate. The sampling rate of combustion products for the measurement of temperature is approximately 100 dm³/h.

For Type B appliances with an outlet diameter of 100 mm or more, the test probe to be used is as shown in Figure 7. Where possible, it is positioned 200 mm from the top of the flue, as shown in Figure 8. When the diameter of the outlet is less than 100 mm, the test probe to be used is as shown in Figure 9. Where possible, it is positioned in the same way as the test probe for the bigger diameters.

For Type C₁₁ appliances, the test probe to be used is as shown in Figure 10. Where possible, it is positioned as shown in Figure 13.

NOTE For Type C₁₁ appliances where the aforementioned location is not appropriate, the sampling position will be by agreement between the manufacturer and the test authority, sufficient measurements being taken to ensure consistency of results.

For Type C₂₁ and C₄₁ appliances, the test probe to be used is as shown in Figure 12. Where possible, it is positioned as shown in Figure 14. Where (a) transfer box(es) is used between the appliance and the common duct system, the test probe is between this transfer box and the common duct system.

For Type C₃₁ appliances with an outlet diameter of 100 mm or more, the test probe to be used is as shown in Figure 7. Where possible, it is positioned 200 mm from the top of the flue; as shown in Figure 8. When the diameter of the outlet is less than 100 mm, the test probe to be used is as shown in Figure 9. Where possible, it is positioned in the same way as the test probe for the bigger diameters.

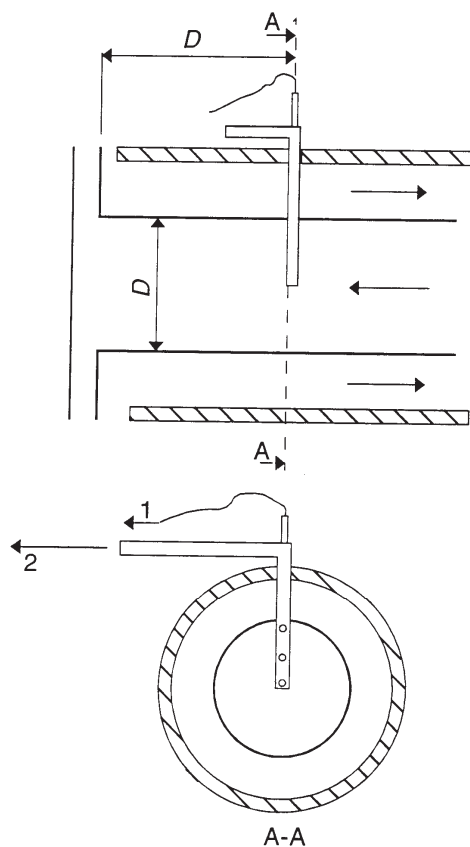

Key

- 1 Lead to temperature indicator
- 2 To sampling pump

Figure 13 — Sampling position for Type C₁₁ appliances

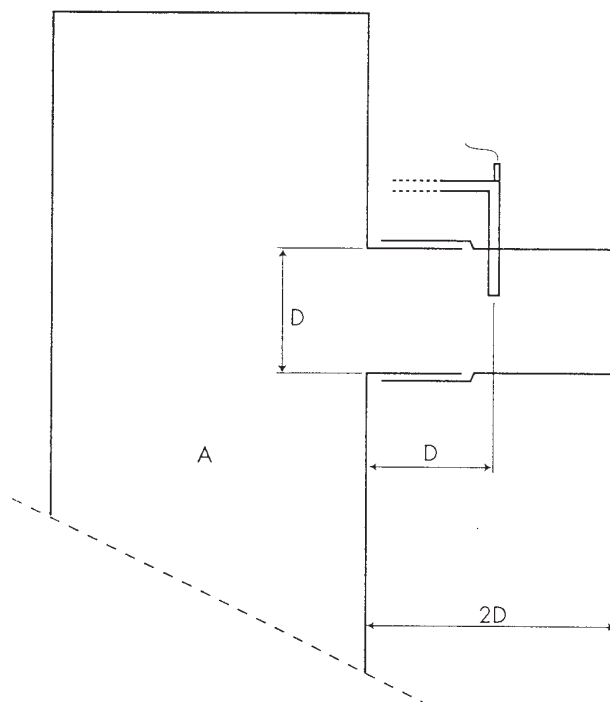

Key
A Appliance
B Internal diameter (D) of the flue outlet

Figure 14 — Sampling position for Type C₂₁ and C₄₁ appliances

7.4.3 Test procedure

With the appliance installed and adjusted as described in 7.4.1.3, the appliance is operated for a sufficient time to reach thermal equilibrium. Measurements are then made of the temperature and the CO₂ concentration of the combustion products and of the combustion air.

The gas rate is measured by timing an integral number of revolutions of the gas meter over a period of at least 100 s.

7.4.4 Accuracy of measurement

The accuracy of the efficiency calculated from the measured values shall be within $\pm 2\%$. Table 10 can be used as guidance.

Table 10 — Measurement accuracy

Quantity measured	Measurement accuracy
Combustion air temperature	$\pm 1,0$ K
Gas temperature	$\pm 1,0$ K
Combustion products temperature	$\pm 2,0$ K
CO ₂ concentration of the combustion air and the combustion products	$\pm 6\%$ of the sample concentration (%)
Gas quantity (volume)	$\pm 1,0$ K
Calorific value	$\pm 0,5\%$

7.4.5 Calculation of efficiency

V_f is calculated from the volume of CO_2 (V_{CO_2}) produced by the combustion of one cubic metre of gas (see Table 14), and from the CO_2 concentration of the products of combustion ($V_{\text{CO}_2,M}$) as given by Equation (14).

$$V_f = 100 \frac{V_{\text{CO}_2}}{V_{\text{CO}_2,M}} \quad (14)$$

Table 2 — V_{CO_2} values

Gas designation	V_{CO_2}
G 110	0,26
G 120	0,32
G 20	1
G 25	0,86
G 30	4
G 31	3

The net efficiency, η_{net} , (in %) is given by Equation (15).

$$\eta_{\text{net}} = 100 - (q_1 + q_2) \quad (15)$$

where

$$q_1 = C_1 V_f \left(\frac{t_2 - t_1}{H_i} \right) 100$$

and

$$q_2 = 0,077(t_2 - t_1) \left(\frac{H_s - H_i}{H_i} \right)$$

and

q_1 is the heat of the dry products of combustion (percentage of heat released per unit volume of gas);

q_2 is the heat of the water vapour contained in the products of combustion (percentage of heat released per unit volume of gas);

C_1 is the mean specific heat of the dry products of combustion in $\text{MJ/m}^3 \cdot \text{K}$ (see Figure 15);

t_1 is the average combustion air temperature in $^{\circ}\text{C}$;

t_2 is the average temperature of the products of combustion in $^{\circ}\text{C}$;

H_i is the net calorific value of the gas at 1 013,25 mbar and 15 $^{\circ}\text{C}$, dry in MJ/m^3 ;

H_s is the gross calorific value of the gas at 1 013,25 mbar and 15 $^{\circ}\text{C}$, dry in MJ/m^3 ;

V_f is the volume of dry products of combustion per unit volume of gas in m^3 .

It is checked that the requirements of 6.2 are satisfied.

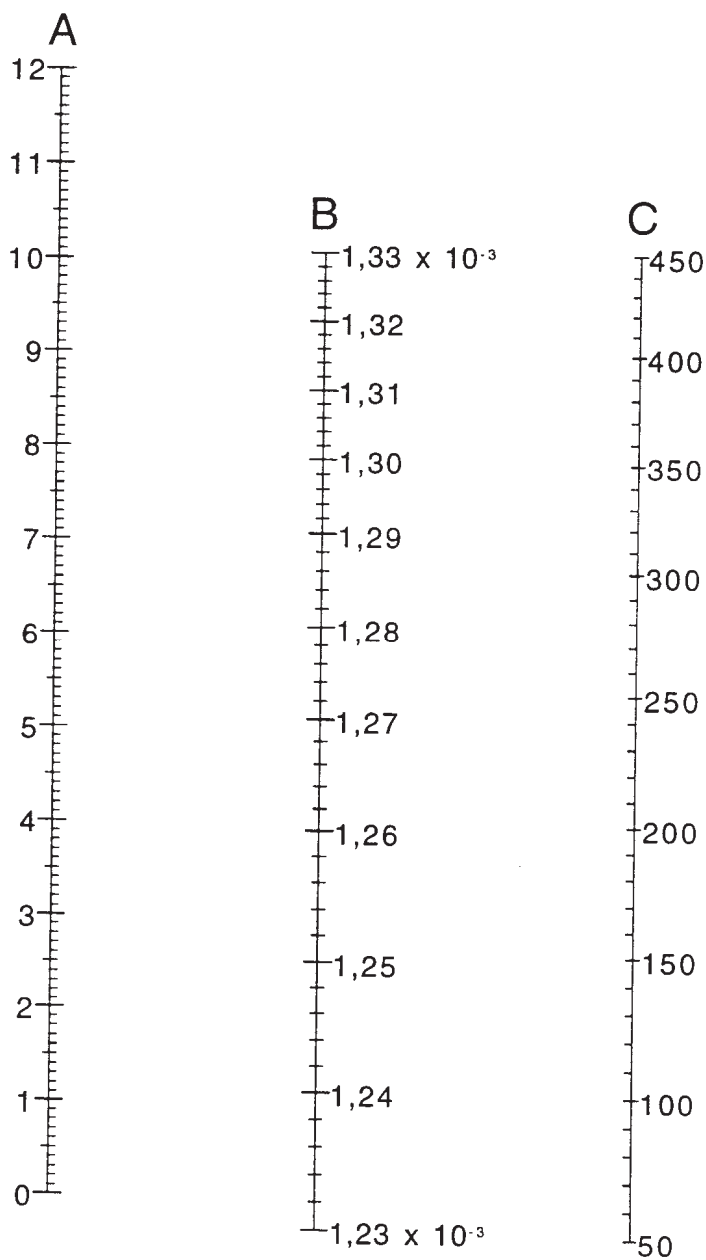

- Key**
- A % CO₂ in combustion products minus % CO₂ in air
 - B Mean specific heat of dry products of combustion in MJ/m³·K
 - C Temperature of combustion products in °C

Figure 15 — Mean specific heat of dry products of combustion

7.4.6 Supplementary test for appliances with a modulating or high/low control

The test is carried out and the efficiency measured as specified in 7.4.1 to 7.4.5, with the appliance adjusted to give the minimum rate.

It is checked that the requirements of 6.2 are satisfied.

8 Marking and instructions

8.1 Marking of the appliance

8.1.1 Description

Appliances are described by their:

- a) category;
- b) nominal input, or range of adjustable inputs.

8.1.2 Data plate

The appliance shall carry one or more data plates and/or labels that are firmly and durably attached to the appliance such that the information given is visible to, and can be read by, the installer. The data plate(s) and/or label(s) shall give at least the following information in indelible⁴⁾ characters:

- a) the manufacturer's⁵⁾ name and address;
- b) the nominal heat input and, where necessary, the range of input for an appliance with an adjustable input, expressed in kilowatts, stating whether it is based on net or gross calorific value;
- c) the trade name of the appliance;
- d) the serial number;
- e) the Product Identification Number (PIN) of the notified body;
- f) the commercial identification of the appliance;
- g) the type of gas in relation to the pressure and/or the pressure couple for which the appliance has been adjusted; any pressure indication shall be identified in relation to the corresponding category index; if an intervention is necessary on the appliance in order to change from one pressure to the other within a pressure couple of the third family, only the pressure corresponding to the current adjustment of the appliance shall be indicated;
- h) the direct country or countries of destination of the appliance;
- i) the appliance category or categories: if more than one appliance category is specified, each of these categories shall be identified in relation with the appropriate direct country or countries of destination;
- j) the setting pressure for regulated appliances;
- k) the nature and voltage of the current used and the maximum electrical input power used (volts, amperes, frequency and kilowatts) for all intended electrical supply conditions.

4) The indelibility of the marking is checked by a test carried out in accordance with 7.14 of EN 60335-1:2002.

5) "Manufacturer" means the person, organization or company who assumes responsibility for designing and manufacturing a product with a view to placing it on the market on their own behalf within the EU.

No other information shall be included on the appliance if this could lead to confusion with regard to the current state of adjustment of the appliance, the corresponding appliance category (or categories) and the direct country (or countries) of destination.

For an appliance with an adjustable nominal input, there shall be room for the installer to durably mark the nominal heat input value for which it has been adjusted on commissioning.

8.1.3 Other marking

The appliance shall be marked with:

For the user:

"Read the user's instructions before lighting the appliance."

For the installer:

"This appliance must be installed in accordance with the rules in force, and used only in a sufficiently ventilated space. Consult instructions before installation and use of this appliance."

For Type B₁₁ appliances, it is necessary to clearly indicate that the appliance is intended to be installed in a space separated from living rooms and provided with appropriate ventilation directly to the outside.

Moreover, if the appliance may cause the temperature of the surroundings to exceed 85 °C as described in 6.2.3.3, it shall also be marked with the following text:

"This appliance shall NOT be installed in a room containing combustible materials".

8.2 Marking of the packaging

The packaging shall show at least:

- a) the type of gas in relation to the pressure and/or the pressure couple, for which the appliance has been adjusted; any pressure indication shall be identified in relation to the corresponding category index; if an intervention is necessary on the appliance in order to change from one pressure to the other within a pressure couple of the third family, only the pressure corresponding to the current adjustment of the appliance shall be indicated;
- b) the direct country or countries of destination of the appliance;
- c) the appliance category or categories: if more than one appliance category is specified, each of these categories shall be identified in relation with the appropriate country or countries of destination.

In addition, it shall be marked with the following text:

"This appliance must be installed in accordance with the rules in force, and used only in a sufficiently ventilated space. Consult instructions before installation and use of this appliance."

Moreover, if the appliance may cause the temperature of the surroundings to exceed 85 °C as described in 6.2.3.3, it shall also be marked with the following text:

"This appliance shall NOT be installed in a room containing combustible materials".

For Type B₁₁ appliances, it is necessary to clearly indicate that the appliance is intended to be installed in a space separated from living rooms and provided with appropriate ventilation directly to the outside.

No other information shall be included on the packaging if this could lead to confusion with regard to the current state of adjustment of the appliance, the corresponding appliance category (or categories) and the direct country (or countries) of destination.

8.3 Utilization of symbols on the appliance and packaging

8.3.1 Electrical supply

The marking concerning electrical values shall be in conformity with EN 60335-1:1988.

8.3.2 Type of gas

In order to represent all of the category indices corresponding to the adjustment of an appliance, the symbol of the reference gas shall be used which is common to all of these indices, in accordance with Table 13.

In order to satisfy the needs expressed by CEN members it is permitted that their countries declared means of identification may be included, in addition to the symbol. These additional means are given in Annex E.

Table 3 — Gas type symbol

Gas type symbol	Corresponding category index	
First family ^{a)}	G 110	1a
	G 120	1b
	G 130	1c
Second family	G 20	2H, 2E, 2E+, 2Esi ^{b)} , 2Er ^{b)} , 2ELL ^{b)}
	G 25	2L, 2Esi ^{c)} , 2Er ^{c)} , 2ELL ^{c)}
Third family	G 30	3B/P, 3+ ^{d) f)} , 3B
	G 31	3+ ^{e) f)} , 3P

^{a)} If, in its current state of adjustment, the appliance can use gases from different groups, all the reference gases corresponding to these groups shall be indicated.

^{b)} When the appliance is adjusted for G 20.

^{c)} When the appliance is adjusted for G 25.

^{d)} Only applies to appliances which do not need any adjustment between G 30 and G 31, or to appliances which need an adjustment and which are adjusted for G 30.

^{e)} Only applies to appliances which need an adjustment between G 30 and G 31, and which are adjusted for G 31.

^{f)} For the appliances which need an adjustment between G 30 and G 31, the label concerning the adjustment to the other gas and the other pressure of the pressure couple shall be supplied with the technical instructions.

8.3.3 Gas supply pressure

The gas supply pressure can be expressed uniquely by the numerical value using the unit (mbar). Nevertheless, if it is necessary to explain this value, the symbol "p" shall be used.

8.3.4 Country of destination

In accordance with EN ISO 3166-1:2006, the names of countries shall be represented by:

AT	Austria	IE	Ireland
BE	Belgium	IS	Iceland
BG	Bulgaria	IT	Italy
CH	Switzerland	LT	Lithuania
CY	Cyprus	LU	Luxembourg
CZ	Czech Republic	LV	Latvia
DE	Germany	NL	Netherlands
DK	Denmark	MT	Malta
EE	Estonia	NO	Norway
ES	Spain	PL	Poland
FI	Finland	PT	Portugal
FR	France	RO	Romania
GB	United Kingdom	SE	Sweden
GR	Greece	SI	Slovenia
HU	Hungary	SK	Slovakia

8.3.5 Category

The category can be expressed uniquely by its designation in accordance with EN 437:2003. Nevertheless, if it is necessary to explain it, the term "category" shall be symbolized by "cat".

8.3.6 Other information

The symbols given below are not obligatory, but are recommended under the title "preferential", and to the exclusion of any other symbol, to avoid the use of many and different markings.

8.3.6.1 Nominal heat input of a burner Q_n .

8.3.6.2 Nominal heat input of all appliance burners ΣQ_n .

8.3.7 Emissions

The manufacturer may choose to declare the weighted NO_x emission value or to express it by a class according to the following list:

- a) Class 1, for values not exceeding 250 mg/kWh;
- b) Class 2, for values not exceeding 200 mg/kWh;
- c) Class 3, for values not exceeding 150 mg/kWh;
- d) Class 4, for values not exceeding 100 mg/kWh;
- e) Class 5, for values not exceeding 50 mg/kWh.

The value or class may be marked on the appliance or contained in the technical data.

8.4 Instructions

8.4.1 General

The instructions shall be written in the official language(s) of the country or countries of destination and shall be valid for that or those countries.

If the instructions are written in an official language that is used by more than one country, the country or countries for which they are valid shall be identified by the codes given in 8.3.4.

Instructions for countries other than those stated on the appliance may be supplied with the appliance, on condition that each set of instructions has the following initial statement:

"These instructions are only valid if the following country code is on the appliance. If this code is not present on the appliance, it is necessary to refer to the technical instructions which will provide the necessary information concerning the modification of the appliance to the conditions of use for the country."

8.4.2 Technical instructions for installation and adjustment

In addition to the information given in 8.2, the technical instructions may include information indicating, where appropriate, that the appliance has been certified for use in countries other than those stated on the appliance⁶⁾. If such information is given, the instructions shall include a warning that modification of the appliance and its method of installation are essential in order to use the appliance safely and correctly in any of these additional countries. This warning shall be repeated in the official language(s) of each of these countries. Furthermore, the instructions shall indicate how to obtain the information, instructions and parts that are necessary for safe and correct use in the countries concerned.

The instructions shall include a statement saying:

"Before installation, check:

- that the local distribution conditions, nature of gas and pressure, and the current state adjustment of the appliance are compatible, and
- that the local electrical supply conditions are compatible with the electrical data given on the data plate."

Taking into account national regulations in this field, if any, the technical instructions for installation and adjustment shall explain the installation conditions for the appliance (on a floor or wall etc.) and its accessories (room thermostat etc.); they shall state the minimum distance necessary between the appliance surfaces (including surfaces of the POCED in the case of Type B₄, C₁ and C₃ appliances) and any nearby walls, and also any precautions to be taken to avoid overheating the floor, walls or ceiling if these are made from combustible materials. These precautions shall include details of any insulation or sleeve required when a POCED passes through a wall or ceiling made from combustible materials. The instructions shall also state the minimum and maximum ambient temperature in which the appliance is designed to operate. They shall include the heat output of the appliance and the NO_x class if declared by the manufacturer.

⁶⁾ Indirect country of destination.

For Type B₁₁ appliances they specify the minimum flue height. For Type B₄₁, and C₃ appliances, they shall specify the minimum and maximum equivalent resistance.⁷⁾

For Type B₄₁, C₁₁ and C₃₁ appliances, the specification shall include a description of the POCED including any bends, its materials of construction and any critical tolerances e.g. in length, diameter, thickness, insertion depth etc; the method of installing the POCED, including any necessary supporting elements, the method of attachment to the building and a statement confirming that the POCED is capable of withstanding its own weight.

For Type B appliances, they shall specify the minimum ventilation requirements for the appliance.

For Type B_{11AS} and B_{11BS} appliances, the instructions shall warn, with respect to the atmosphere sensing device and the combustion products discharge safety device, as applicable:

- a) that the device is a very important safety device;
- b) that the device shall not be adjusted by the installer;
- c) that the device shall not be put out of operation; and
- d) that, when the device, or any of its parts is exchanged, only original manufacturer's parts shall be used.

They shall also give all relevant information for adjusting the gas rate. They shall also include a table for the appliance category, giving the various calorific values and the gas rate settings, in m³/h in relation to the average conditions of use (15 °C, 1 013,25 mbar) or in kg/h, together with the instructions about how to adjust the air rate.

They shall explain the operations and adjustment to be carried out when converting from one gas to another and, in particular, the markings on the parts and injectors supplied for each of the gases which may be used.

They shall deal with the maintenance, replacement and cleaning of functional parts where necessary.

To aid understanding, the technical instructions shall contain a description of the appliance and of the exchangeable or conversion parts with an illustration and, where necessary, a numbered key for identifying the main parts to be cleaned, serviced or replaced.

8.4.3 Instructions for the user

All the instructions shall be provided by the manufacturer. The instructions for the user shall provide all the necessary information for the safe and sensible use of the appliance.

In particular, they shall deal with the operations of ignition and extinction, the use of the various controls with which the appliance may be fitted, simple cleaning and maintenance of the appliance, also mentioning, where necessary, the nature of the materials recommended. They shall also stress that a qualified installer is required to install, adjust and, where necessary, convert the appliance for use with other gases.

They shall also state the recommended frequency of periodic servicing.

⁷⁾ In the case of type B₄₁ and C₃₁ appliances the minimum and maximum equivalent resistance corresponds to the POCED supplied or specified by the manufacture with the minimum and maximum resistance to flow. Due account shall be taken of the resistance to flow of any terminal supplied or specified by the manufacturer.

9 Evaluation of POCED conformity and their associated terminals

9.1 General

The compliance of a POCED and its associated terminal shall be demonstrated by

- a) initial type testing;
- b) factory production control by the manufacturer, including product assessment.

NOTE The requirements are given in the relevant Tables ZB.1 or ZB.2.

9.2 Type testing

9.2.1 Initial type testing

Initial type testing shall be performed to show conformity the requirements of this standard.

NOTE The requirements are given in the relevant Tables ZB.1 or ZB.2.

Tests previously performed in accordance with the provisions of this standard [same product, same characteristic(s), test method, sampling procedure, system of attestation of conformity, etc.] may be taken into account. In addition, initial type testing shall be performed at the beginning of the production of a new POCED and/or its associated terminal, or at the beginning of a new method of production (where this may affect the stated properties).

Where characteristics are determined on the basis of conformity with other product standards (for, metals including coatings, seals and sealants), these characteristics do not need to be reassessed provided that the designer ensures the validity of the results. Products CE marked in accordance with appropriate harmonised European specifications may be presumed to have the performances stated of them, although this does not replace the responsibility of the manufacturer to ensure that the POCED and any associated terminal as a whole is correctly designed and its component products have the necessary performance values.

9.2.2 Further type testing

Whenever a change occurs in the POCED, any associated terminal, the raw material or supplier of the components, or the production process, which would change the tolerances or one or more of the characteristics that are assessed by the requirements, the type tests shall be repeated for the appropriate characteristic(s).

9.2.3 Sampling for type testing

Unless otherwise stated in the particular test method given in Clause 7 of this standard, type testing is carried out utilising a POCED, and any associated terminal, having the minimum and maximum equivalent resistance.

The results of all type tests shall be recorded and held by the manufacturer, until superseded.

9.3 Factory production control (FPC)

9.3.1 General

NOTE 1 A FPC system conforming with the following requirements of the relevant part(s) of EN ISO 9001:2008, and made specific to the requirements of this standard, is considered to satisfy the above requirements.

The manufacturer shall establish, document and maintain a FPC system to ensure that the manufactured products conform to the stated performance characteristics. The FPC system shall consist of procedures,

regular inspections and tests and/or assessments and the use of the results, for example, to control raw and other incoming materials or components, equipment, the production process and the product.

The manufacturer is responsible for organising the effective implementation of the factory production control system. Tasks and responsibilities in the production control organisation should be documented and this documentation should be kept up to-date. In each factory, the manufacturer may delegate the action to a person having the necessary authority to:

- identify procedures to demonstrate conformity of the product at appropriate stages;
- identify and record any instance of non-conformity;
- identify procedures to correct instances of non conformity.

The manufacturer should draw up and keep up-to-date documents defining the factory production control which he applies. The manufacturer's documentation and procedures should be appropriate to the product and manufacturing process. All FPC systems should achieve an appropriate level of confidence in the conformity of the product. This involves:

The preparation of documented procedures and instructions relating to factory production control operations, in accordance with the requirements of the reference technical specification;

- the effective implementation of these procedures and instructions;
- the recording of these operations and their results;
- the use of these results to correct any deviations, repair the effects of such deviations, treat any resulting instances of non-conformity and, if necessary, revise the FPC to rectify the cause of non-conformity.

The production control operations shall include some or all of:

- the specification and verification of raw materials and constituents;
- the controls and tests to be carried out during manufacture according to a frequency laid down;
- the verifications and tests to be carried out on finished products according to a frequency which may be laid down in the technical specifications and adapted to the product and its conditions of manufacture.

NOTE 2 Depending on the specific case, it may be necessary to carry out:

- 1) the operations referred to under 9.3.1 h) and 9.3.1 i),
- 2) only the operations under 9.3.1 h) or,
- 3) only those under 9.3.1 i).

The operations under 9.3.1 i) centre as much on the intermediate states of the product as on manufacturing machines and their adjustment, and equipment. These controls and tests and their frequency are chosen based on product type and composition, the manufacturing process and its complexity, the sensitivity of product features to variations in manufacturing parameters.

The manufacturer shall have or have available the installations, equipment and personnel which enable him to carry out the necessary verifications and tests. He may, as may his agent, meet this requirement by concluding a sub-contracting agreement with one or more organisations or persons having the necessary skills and equipment.

The manufacturer has responsibility to calibrate or verify and maintain the control, measuring or test equipment in good operating condition, whether or not it belongs to him, with a view to demonstrating conformity of the product with its technical specification. The equipment shall be used in conformity with the specification or the test reference system to which the specification refers.

If necessary, monitoring is carried out of the conformity of intermediate states of the product and at the main stages of its production.

This monitoring of conformity focuses where necessary on the product throughout the process of manufacture, so that only products having passed the scheduled intermediate controls and tests are dispatched.

The results of inspections, tests or assessments requiring action shall be recorded, as any action taken. The action to be taken when control values or criteria are not met shall be recorded.

9.3.2 Equipment

All weighing, measuring and testing equipment shall be calibrated and regularly inspected according to documented procedures, frequencies and criteria.

9.3.3 Raw materials and components

The specifications of all incoming raw materials and components shall be documented, as the inspection scheme for ensuring their conformity.

9.3.4 Product testing and evaluation

The manufacturer shall establish procedures to ensure that the stated values of the characteristics are maintained. An example of a sampling plan for FPC is given in Annex H.

9.3.5 Non-conforming products

The manufacturer shall establish procedures for dealing with non-conforming products.

Annex A (informative)

National situations⁸⁾

A.1 General

In each country in which this standard applies, appliances may be marketed only if they comply with the particular national supply conditions of that country.

In order to permit, both at the time of testing the appliance and at the time of its sale, the correct choice to be made from all the situations covered, the various national situations are summarized in A.2, A.3, A.4, A.5 A.6 and A.7.

A.2 Categories listed in the body of the standard and marketed in different countries

Tables A.1 and A.2 give the national situations concerning the marketing in the various countries of the appliance categories listed in the body of the standard.

The information given in the table indicates only that these categories may be sold throughout the whole of the country concerned and A.3 should be consulted for confirmation.

In all cases of doubt, the local gas supplier should be consulted in order to identify the precise category applicable.

⁸⁾ This annex does not apply to the POCEDS(chimneys)

Table A.1 — Category I (single categories) marketed

Country	I _{2H}	I _{2L}	I _{2E}	I _{2E+}	I _{2N} ^{a)}	I _{2R} ^{a)}	I _{3B/P}	I ₃₊	I _{3P}	I _{3B}	I _{3R} ^{a)}
AT	X						X				
BE				X				X	X		
BG											
CH	X						X	X	X		
CY ^{b)}											
CZ	X						X		X		
DE			X				X		X		
DK	X						X				
EE ^{b)}											
ES	X							X	X		
FI	X						X				
FR	X ^{c)}	X ^{c)}		X			X ^{d)}	X	X		
GB	X							X	X		
GR	X							X	X		
HU ^{b)}	X						X		X	X	
IE	X							X	X		
IS											
IT	X							X			
LT ^{b)}											
LU			X								
LV ^{b)}											
MT ^{b)}											
NL	X ^{c)}	X					X		X		
NO							X				
PL			X				X		X		
PT	X							X	X		
SE	X						X				
SI	X				X	X	X	X	X		X
SK ^{b)}											

^{a)} Category to be deleted if it is not selected by any country.

^{b)} Information on categories to be supplied by new CEN member.

^{c)} Categories applicable only to certain types of appliance, submitted to on site EC verification procedure, Annex II, article 6 of the Gas Appliance Directive (90/396/EEC). (France and Netherlands to clarify if applicable here).

^{d)} Categories applicable only to certain types of appliance specified in the individual standards (France to specify if applicable here).

Table A.2 — Double categories marketed

Country	_{1a2H}	_{2H3B/P}	_{2H3+}	_{2H3P}	_{2H3B}	_{2L3B/P}	_{2L3P}	_{2E3B/P}	_{2E3+B/P}	_{2E+3+}	_{2E+3P}	_{2R3R} ^a
AT		X										
BE												
BG												
CH	X	X	X	X								
CY ^b												
CZ		X		X								
DE								X				
DK	X	X										
EE ^b												
ES			X ^c	X								
FI		X										
FR				X ^d			X ^d		X ^e	X	X	
GB			X	X								
GR		X	X	X								
HU ^b		X		X	X							
IE			X	X								
IS												
IT	X		X									
LT ^b												
LU												
LV ^b												
MT ^b												
NL						X	X					
NO												
PL								X				
PT			X	X								
SE	X	X										
SI		X	X	X								X
SK ^b												

^a Category to be deleted if it is not selected by any country.

^b Information on categories to be supplied by new CEN member.

^c Appliances of this Category set for Group H gases of the second family may use air and commercial propane gas mixtures where the gross wobble index (at 15°C and 1 013,25 mbar) is between 46 MJ/m³ and 51,5 MJ/m³ a, at the same supply pressure, without additional tests.

^d Categories applicable only to certain types of appliance, submitted to on site EC verification procedure, Annex II, article 6 of the Gas Appliance Directive (90/396/eec). (France to clarify if applicable here).

^e Categories applicable only to certain types of appliance specified in the individual standards (France to specify if applicable here).

A.3 Appliance supply pressures corresponding to the categories given in A.2

Table A.3 gives the conditions in the various countries concerning the supply pressures to appliances in the categories given in A.2

Other, higher supply pressures may be necessary and such pressures may be provided after consultation with the appropriate gas supplier(s) in the country(ies) concerned.

Table A.3 — Normal supply pressures

Gas	G 110	G 20	G 25		G 20 + G 25	G 30		G 31			G 30 + G 31	
Pressure (mbar)	8	20	20	25	Couple 20/25	30 28-30	50	30	37	50	Couple 28-30/37	Couple 50/67
Country												
AT		X					X			X		
BE					X					X ^a	X	X
BG												
CH		X					X			X	X	
CY ^{b)}												
CZ		X ^{c)}					X ^{d)}	X	X	X ^{e)}		
DE		X	X			X	X			X		
DK	X	X						X				
EE ^{b)}												
ES		X				X			X	X ^{a)}	X	
FI		X				X		X				
FR					X	X	X ^{a)}		x	X ^{a)}	X	
GB		X ^{b)}				X			X	X	X	
GR		X				X		X	X	X	x	
HU ^{b)}		X ^{g)}				X	X	X		x		
IE		X				X			X		X	
IS												
IT	X	X									X	
LT ^{b)}												
LU		X										
LV ^{b)}												
MT ^{b)}												
NL				X				X		X		
NO						X		X				
PL		X							X			
PT		X				X			X		X	
SE	X	X				X		X				
SI		X				X			X		X	
SK ^{b)}												

- a) Only for certain types of non-domestic appliances. (Countries to clarify)
b) Information on supply pressures to be supplied by new CEN member.
c) Currently 18 mbar.
d) For certain types of industrial appliances. (CZ to clarify).
e) For certain types of appliances. (CZ to clarify)
f) Normal supply pressure for this appliance: 17,5 mbar.
g) Pressures of 25mbar and 85 mbar.

A.4 Special categories marketed nationally or locally

A.4.1 General

The national or local conditions of gas distribution (gas composition and supply pressures) lead to the definition of special categories which are marketed nationally or locally in certain countries, as shown in Table A.4.

Table A.4 — Test gases corresponding to categories marketed nationally or locally

Category	Reference gas	Incomplete combustion limit gas	Light back limit gas	Lift limit gas	Sooting limit gas	Country
I _{2Esi} , I _{2Er}	G 20, G 25	G 21	G 222	G 231	G 21	FR
I _{2E(S)B}	G 20, G 25	G 21	G 222	G 231	G 21	BE
I _{2E(R)B}	G 20, G 25	G 21	G 222	G 231	G 21	BE
I _{2ELL}	G 20, G 25	G 21	G 222	G 231, G 271	G 21	DE
I _{2S}	G 25.1	G 26.1	G 222	G 27.1	G 26.1	HU ^a
I _{2HS}	G 20, G 25.1	G 21, G 26.1	G 222	G 27.1	G 21, G 26.1	HU ^a
I _{2ELw}	G 20, G 27	G 21	G 222	G 2.412	G 21	PL
I _{2ELs}	G 20, G 2.350	G 21	G 222	G 2.352	G 21	PL
I _{2ELn}	G 20, G 2.300	G 21	G 222	G 2.302	G 21	PL
I _{2ELwLs}	G 20, G 27, G 2.350	G 21	G 222	G 2.352	G 21	PL
I _{2ELwLsLn}	G 20, G27, G2.350, G 2.300	G 21	G 222	G 2.302		PL
I _{3B/P} ^b	G 30	G 30	G 32	G 31	G 30	PL
I _{3P(B/P)} ^b	G 31, G 30	G 31, G 30	G 32	G 31	G 30	PL
II _{1c2H}	G 130, G 20	G 21	G 132, G 222	G 23	G 21	CH
II _{2Esi3+} II _{2Er3+}	G 20, G 25 G 30	G 21	G 222 G 32	G 231 G 31	G 30	FR
II _{2Esi3P} II _{2Er3P}	G 20, G 25 G 31	G 21	G 222 G 32	G 231 G 271	G 31 G 32	FR
II _{2ELL3B/P}	G 20, G 25, G 30	G 21, G 30	G 222, G 32	G 231 G 271	G 30	DE
II _{2S3B/P}	G 25.1, G 30	G 26.1, G 30	G 32	G 27.1 G 31	G 26.1, G 30	HU ^a
II _{2S3P}	G25.1, G 31	G 26.1, G 30	G 32	G 27.1, G 31	G 26.1, G 31, G 32	HU ^a
II _{2S3B}	G 25.1, G 30	G 26.1, G 30	G 32	G 27.1, G 31	G 26.1, G 30	HU ^a
II _{2HS3B/P}	G 20, G 25.1 G 30	G 21, G 26.1, G 30	G 222 G 32	G 23, G 27.1, G 31	G 21, G 26.1, G 30	HU ^a
II _{2HS3P}	G 20, G 25.1 G 31	G 21, G 26.1, G 30	G 222 G 32	G 23, G 271, G 31	G 21, G 26.1, G 31, G 32	HU ^a
II _{2HS3B}	G 20, G 25.1 G 30	G 21, G 26.1, G 30	G 222 G 32	G 23, G 271, G 31	G 21, G 26.1, G 30	HU ^a
II _{1Lm2E}	G1.250, G 20	G 21	G 1,252, G 222	G 1,252	G 21	PL
II _{1Lm2ELwLsLn}	G.1250, G 20, G 27, G 2.350, G 2.300	G 21	G 1,252, G 222	G 1,252	G 21	PL
II _{2E3B/P}	G 20, G 30	G 21	G 222, G 32	G 231, G31	G 30	PL
II _{2E3P}	G 20, G 31	G 21	G 222, G 32	G 231, G31	-	PL

Table A.4 (continued)

Category	Reference gas	Incomplete combustion limit gas	Light back limit gas	Lift limit gas	Sooting limit gas	Country
II _{2E3P(B/P)} ^b	G 20, G30, G 31	G 21	G 222, G 32	G 231, G31	G 30	PL
II _{2EIs3B/P}	G 20, G 2.350, G 30	G 21	G 222, G 32	G 2.352 G 31	G 30	PL
II _{2EIs3P}	G 20, G 2.350, G 31	G 21	G 222, G 32	G 2.352 G 31	-	PL
II _{2ELwLs3B/P}	G 20, G 27, G 2.350, G 30	G 21	G 222, G 32	G 2.352 G 31	G 30	PL
II _{2ELwLs3P}	G 20, G 27, G 2.350, G 31	G 21	G 222, G 32	G 2.352 G 31	-	PL
II _{2ELwLs3P(B/P)} ^b	G 20, G 27, G 2.350, G 31, G 30	G 21	G 222, G 32	G 2.352 G 31	G 30	PL
II _{2ELwLsLn3P(B/P)} ^b	G 20, G 27, G 2.350, G 2.300 G 31, G 30	G 21	G 222, G 32	G 2.302 G 31	G 30	PL
III _{1a2H3B/P}	G 110, G 20 G 30	G 21	G 112 G 222, G 32	G 23 G 31	G 30	DK, IT
III _{1c2H3B/P}	G 130, G 20 G 30	G 21	G 132 G 222, G 32	G 23 G 31	G 30	CH
III _{1c2H3+}	G 130, G 20 G 30	G 21	G 132 G 222, G 32	G 23 G 31	G 30	CH
III _{1c2H3P}	G 130, G 20, G 30	G 21	G 132 G 222, G 32	G 23 G 31 G 32	G 31 G 32	CH
III _{1c2E+3+}	G 130, G 20, G 30	G 21	G 132 G 222, G 32	G 231 G 31	G 30	FR
III _{1c2E+3P}	G 130, G 20 G 31	G 21	G 132 G 222, G 32	G 231 G 31	G 32	FR
III _{1c2Esi3+} III _{1c2Er3+}	G 130, G 20 G 25, G 30	G 21	G 132 G 222, G 32	G 231 G 31	G 30	FR
III _{1c2Esi3P} III _{1c2Er3P}	G 130, G 20 G 25, G 31	G 21	G 132 G 222, G 32	G 231 G 31	G 32	FR
III _{1ab2H3B/P}	G 110, G 120 G 20, G 30	G 21	G 112 G 222, G 32	G 23 G 31	G 30	SE
III _{1c2E3B/P}	G 130, G 20, G 30	G 21	G 132, G 222, G 32	G 31	G 30	PL
III _{1Lm2ELwLsLn3B/P}	G 1.250, G20, G 27, G 2.350, G 2.300, G 30	G 21	G 1.252, G 222, G 32	G 1.252 G 31	G 30	PL
^a	Hungary to confirm selection.					
^b	Only used on appliances less than 12kW and at normal pressure of 37 mbar for both butane and propane					

A.4.2 Definition of special categories

The definitions of the special categories given in Table A.4 are derived in the same way as those categories listed in 4.2. The characteristics of the gases distributed regionally are given in A.5.

A.4.2.1 Category I

A.4.2.1.1 Appliances designed for the use of gases linked to the first family

Category I_{1b}: appliances using only gases of Group b linked to the first family, at a fixed supply pressure (this category is not used).

Category I_{1c}: appliances using only gases of Group c linked to the first family, at a fixed supply pressure (this category is not used).

Adjustment of the gas rate is optional for the replacement of a gas of one group to a gas of another group within the first family and of the gases which are linked to it.

Category I_{1Lm}: appliances using only of group Lm gases linked to the first family at the prescribed supply pressure (this category is not used).

A.4.2.1.2 Appliances designed for the use of gases of the second family and the gases linked to it

Category I_{2Esi}: appliances capable of using only gases of Group E of the second family, and operating under the appropriate pressure of a pressure couple. The replacement of a gas in the range Es of Group E (Wobbe index between 44,8 MJ/m³ and 54,7 MJ/m³) by a gas in the range Ei of Group E (Wobbe index in the range 40,9 MJ/m³ and 44,8 MJ/m³) or vice versa necessitates a modification to the burner setting and possibly a change of injectors, of calibrated orifices and of the atmosphere control device.

Category I_{2Er}: appliances capable of using only gases of Group E of the second family and being able to operate with a pressure couple without adjustment on the appliance. However, specific adjustment of the burner gas rate is optional for the replacement of a gas of the range Es of Group E (Wobbe index between 44,8 MJ/m³ and 54,7 MJ/m³) by a gas of the range Ei of Group E (Wobbe index between 40,9 MJ/m³ and 44,8 MJ/m³). If this adjustment has been carried out, a re-adjustment to the previous setting is then necessary in order to return to the use of a gas in the range Es of Group E.

Category I_{2LL}: appliances using only gases of Group LL linked to the second family, at a fixed supply pressure. On condition that the Wobbe index of the second family gas distributed does not exceed the upper limit of 43,7 MJ/m³, the appliance may be adjusted according to a lower nominal value (this category is not used).

Category I_{2ELL}: appliances capable of using gases of Group E of the second family, and gases of Group LL linked to the second family. The gases of Group E of the second family are used under the same conditions as for Category I_{2E}. The gases of Group LL of the second family are used under the same conditions as for Category I_{2LL}.

Category I_{2S}: appliances using only gases of Group S linked to the second family, at the defined supply pressure.

Category I_{2HS}: appliances using only gases of Group H of the second family and gases of Group S linked to the second family. The Group H second family gases are used under the same conditions as for Category I_{2H}. The Group S second family gases are used under the same conditions as for Category I_{2S}.

Category I_{2Lw}: appliances using only of group Lw gases linked to the second family at the prescribed supply pressure (this category is not used).

Category I_{2Ls}: appliances using only of group Ls gases linked to the second family at the prescribed supply pressure (this category is not used).

Category I_{2Ln}: appliances using only of group Ln gases linked to the second family at the prescribed supply pressure (this category is not used).

Category I_{2ELWLS}: appliances capable of using gases of group E second family and gases group Lw and Ls linked to the second family. The gases of group E are used under the same conditions as for category I_{2E}. The gases group Lw and Ls are used accordingly under the same conditions as for category I_{2Lw} and category I_{2Ls}.

Category I_{2ELWLSLn}: appliances capable of using gases of group E second family and gases group Lw, Ls and Ln linked to the second family. The gases of group E are used under the same conditions as for category I_{2E}. The gases group Lw, Ls and Ln are used accordingly under the same conditions as for category I_{2Lw}, category I_{2Ls} and category I_{2Ln}.

A.4.2.1.3 Appliances designed for the use of gases of the third family and the gases linked to it

Category I_{3P(B/P)}: appliances capable of using gases of group P and B/P third family. The gases of group P are used under the same conditions as for category I_{3P}. The gases group B/P are used under the same conditions as for category I_{3B/P}.

A.4.2.2 Category II

A.4.2.2.1 Appliances designed to use gases of the first family or that are linked to it and gases of the second family or that are linked to it

Category II_{1Lm2ELWLSLn}: appliances capable of using of group Lm gases linked to the first family and gases of group E, Lw, Ls, Ln of the second family or linked to the second family. The gases linked to the first family are used under the same conditions as for category I_{1Lm}. The second family gases are used under the same conditions as for category I_{2ELWLSLn}.

A.4.2.2.2 Appliances designed to use of gases of the second family or that are linked to it and gases of the third family

Category II_{2Esi3+}: appliances capable of using gases of Group E of the second family and gases of the third family. The second family gases are used under the same conditions as for Category I_{2Esi}. The third family gases are used under the same conditions as for Category I₃₊.

Category II_{2Esi3P}: appliances capable of using gases of Group E of the second family and gases of Group P of the third family. The second family gases are used under the same conditions as for Category I_{2Esi}. The gases of the third family are used under the same conditions as for Category I_{3P}.

Category II_{2Er3+}: appliances capable of using gases of Group E of the second family and gases of the third family. The second family gases are used under the same conditions as for Category I_{2Er}. The gases of the third family are used under the same conditions as for Category I₃₊.

Category II_{2Er3P}: appliances capable of using gases of Group E of the second family and gases of Group P of the third family. The second family gases are used under the same conditions as for Category I_{2Er}. The gases of the third family are used under the same conditions as for Category I_{3P}.

Category II_{2ELL3B/P}: appliances capable of using gases of Group E of the second family, gases of Group LL linked to the second family and gases of the third family. The second family gases or the gases that are linked to it are used under the same conditions as for Category I_{2ELL}. Gases of the third family are used under the same conditions as for Category I_{3B/P}.

Category II_{2S3B/P}: appliances capable of using gases of Group S linked to the second family and gases of the third family. The gases linked to the second family are used under the same conditions as for Category I_{2S}. The third family gases are used under the same conditions as for Category I_{3B/P}.

Category II_{2S3P}: appliances capable of using gases of Group S linked to the second family and gases of Group P of the third family. The gases linked to the second family are used under the same conditions as for Category I_{2S}. The third family gases are used under the same conditions as for Category I_{3P}.

Category II_{2S3B}: appliances capable of using gases of Group S linked to the second family and gases of Group B of the third family. The gases linked to the second family are used under the same conditions as for Category I_{2S}. The third family gases are used under the same conditions as for Category I_{3B}.

Category II_{2HS3B/P}: appliances capable of using gases of Group H of the second family, gases of Group S linked to the second family and gases of the third family. Gases of the second family or gases linked to it are used under the same conditions as for Category I_{2HS}. The third family gases are used under the same conditions as for Category I_{3B/P}.

Category II_{2HS3P}: appliances capable of using gases of Group H of the second family, gases of Group S linked to the second family and gases of Group P of the third family. Gases of the second family or gases linked to it are used under the same conditions as for Category I_{2HS}. The third family gases are used under the same conditions as for Category I_{3P}.

Category II_{2HS3B}: appliances capable of using gases of Group H of the second family, gases of Group S linked to the second family and gases of Group B of the third family. Gases of the second family or gases linked to it are used under the same conditions as for Category I_{2HS}. The third family gases are used under the same conditions as for Category I_{3B}.

Category II_{2E3P(B/P)}: appliances capable of using gases of group E of the second family and gases of groups P and B/P of the third family. The second family gases are used under the same conditions as for category I_{2E}. The gases of the third family are used under the same conditions as for category I_{3P(B/P)}.

Category II_{2ELwLsLn3B/P}: appliances capable of using gases of group E of the second family, gases groups Lw, Ls, Ln linked to the second family and gases of group B/P of the third family. The second family gases are used under the same conditions as for category I_{2ELwLsLn}. The gases of the third family are used under the same conditions as for category I_{3B/P}.

Category II_{2ELwLsLn3P}: appliances capable of using gases of group E of the second family, gases groups Lw, Ls, Ln linked to the second family and gases of group P of the third family. The second family gases are used under the same conditions as for category I_{2ELwLsLn}. The gases of the third family are used under the same conditions as for category I_{3P}.

Category II_{2ELwLsLn3P(B/P)}: appliances capable of using gases of group E of the second family, gases groups Lw, Ls, Ln linked to the second family and gases of group P and B/P of the third family. The second family gases are used under the same conditions as for category I_{2ELwLsLn}. The gases of the third family are used under the same conditions as for category I_{3P(B/P)}.

A.4.2.3 Category III

Category III_{1a2H3B/P}: appliances capable of using gases of Group a of the first family, gases of Group H of the second family and gases of the third family. The first family gases are used under the same conditions as for Category I_{1a}. The second family gases are used under the same conditions as for Category I_{2H}. The third family gases are used under the same conditions as for Category I_{3B/P}.

Category III_{1c2E+3+}: appliances capable of using gases of Group c linked to the first family, gases of Group E of the second family and gases of the third family. The gases linked to the first family are used under the

same conditions as for Category I_{1c}. The second family gases are used under the same conditions as for Category I_{2E+}. The third family gases are used under the same conditions as for Category I₃₊.

Category III_{1c2E+3P}: appliances capable of using gases of Group c linked to the first family, gases of Group E of the second family and gases of Group P of the third family. The gases linked to the first family are used under the same conditions as for Category I_{1c}. The second family gases are used under the same conditions as for Category I_{2E+}. The third family gases are used under the same conditions as for Category I_{3P}.

Category III_{1c2Esi3+}: appliances capable of using gases of Group c linked to the first family, gases of Group E of the second family and gases of the third family. The gases linked to the first family are used under the same conditions as for Category I_{1c}. The second family gases are used under the same conditions as for Category I_{2Esi}. The third family gases are used under the same conditions as for Category I₃₊.

Category III_{1c2Esi3P}: appliances capable of using gases of Group c linked to the first family, gases of Group E of the second family and gases of the third family. The gases linked to the first family are used under the same conditions as for Category I_{1c}. The second family gases are used under the same conditions as for Category I_{2Esi}. The third family gases are used under the same conditions as for Category I_{3P}.

Category III_{1c2Er3+}: appliances capable of using gases of Group c linked to the first family, gases of Group E of the second family and gases of the third family. The gases linked to the first family are used under the same conditions as for Category I_{1c}. The second family gases are used under the same conditions as for Category I_{2Er}. The third family gases are used under the same conditions as for Category I₃₊.

Category III_{1c2Er3P}: appliances capable of using gases of Group c linked to the first family, gases of Group E of the second family and gases of Group P of the third family. The gases linked to the first family are used under the same conditions as for Category I_{1c}. The second family gases are used under the same conditions as for Category I_{2Er}. The third family gases are used under the same conditions as for Category I_{3P}.

Category III_{1ab2H3B/P}: appliances capable of using gases of Group a of the first family, gases of Group b linked to the first family, gases of Group H of the second family and gases of the third family. The first family gases or the gases linked to it are used under the same conditions as for categories I_{1a} and I_{1b}. The second family gases are used under the same conditions as for Category I_{2H}. The third family gases are used under the same conditions as for Category I_{3B/P}.

Category III_{1Lm2ELwLsLn3B/P}: appliances capable of using gases of group Lm linked to the first family, gases of group E of the second family, gases groups Lw,Ls,Ln linked to the second family and gases of group B/P of the third family. The first family gases are used under the same conditions as for category I_{1Lm}. The second family gases are used under the same conditions as for category I_{2ELwLsLn}. The third family gases are used under the same conditions as for category I_{3B/P}.

A.4.3 Gas rate adjusters, aeration adjusters and regulators

This clause has been included to enable CEN members to provide information equivalent to that given in 5.2.2, 5.2.3, 5.2.4 and 5.2.6 in relation to the special categories they have requested, detailed in A.4.1.

A.4.4 Conversion to different gases

This clause has been included to enable certain member states to provide information equivalent to that given in 5.1.1.1 in relation to the special appliance categories listed in A.4.1.

A.5 Test gases corresponding to the special categories given in A.4

The characteristics of the test gases corresponding to the gases distributed nationally or locally and the corresponding test pressures are given in Table A.5 (reference conditions only).

Mixtures of gases of Group a with gases of Groups c or e, where the Wobbe index is between 21,1 MJ/m³ and 24,8 MJ/m³ are also linked to Group a of the first family.

These mixtures may only be used without supplementary tests in appliances in multiple categories including Group a of the first family.

Table A.5 — Test gases corresponding to local situations

Gas family and group		Nature of gas	Designation	Composition Volume %	Wl MJ/m ³	HI MJ/m ³	Ws MJ/m ³	Hs MJ/m ³	d	Test Pressure mbar	Country
Gases linked to the first family	Group b	Reference Incomplete combustion Sooting	G 120	H ₂ = 47 CH ₄ = 32 N ₂ = 21	24,40	15,68	27,64	17,77	0,4 13	p _n = 8 p _{min} = 6 p _{max} = 15	SE
		Light back	G 112	H ₂ = 59 CH ₄ = 17 N ₂ = 24	19,48	11,81	22,36	13,56	0,3 67		
	Group c	Reference (Propane-air)	G 130	C ₃ H ₈ = 26,9 Air = 73,1 ^{a)}	22,14	23,66	24,07	25,72	1,1 42	FR: p _n = 8 p _{min} = 6 p _{max} = 15 PL: p _n = 20 p _{min} = 16 p _{max} = 23	FR PL
		Light back	G 132	C ₃ H ₈ = 13,8 C ₃ H ₆ = 13,8 Air ^{a)} = 72,4	22,10	23,56	23,84	25,41	1,1 36		
	Group Lm	Reference	G 1.250	CH ₄ = 54 N ₂ = 46	21,27	18,36	23,64	20,40	0,7 45	PL: p _n = 8 p _{min} = 6 p _{max} = 11	PL
		Incomplete combustion	G 1.251 ^{c)}	CH ₄ = 58 N ₂ = 42	23,12	19,73	25,68	21,31	0,7 28		
Light back limit Flame lift limit		G 1.252	CH ₄ = 50 N ₂ = 50	19,48	17,00	21,65	18,89	0,7 61			
Gases Linked to the second family	Group Lw	Reference	G 27	CH ₄ = 82 N ₂ = 18	35,17	27,89	39,06	30,98	0,6 29	p _n = 20 p _{min} = 16 p _{max} = 23	PL
		Incomplete combustion	G 2.411	CH ₄ = 89 N ₂ = 11	39,09	30,28	43,40	33,62	0,6 00		
		Light back limit Flame lift limit	G 2.412	CH ₄ = 76 N ₂ = 24	31,96	25,85	35,50	28,71	0,6 54		
	Group Ls	Reference	G 2.350	CH ₄ = 72 N ₂ = 28	29,67	24,49	33,22	27,20	0,6 70	p _n = 13 p _{min} = 10 p _{max} = 16	
		Incomplete combustion	G 2.351	CH ₄ = 77 N ₂ = 23	32,48	26,19	36,09	29,09	0,6 50		
		Light back limit Flame lift limit	G 2.352	CH ₄ = 67 N ₂ = 33	27,42	22,79	30,15	25,31	0,6 91		
	Group Ln	Reference	G 2.300	CH ₄ = 63 N ₂ = 37	25,49	21,43	28,30	23,80	0,7 07	p _n = 13 p _{min} = 10 p _{max} = 16	
		Incomplete combustion	G 2.301	CH ₄ = 68 N ₂ = 32	27,91	23,13	31,00	25,69	0,6 87		
		Light back limit Flame lift limit	G 2.302 ^{c)}	CH ₄ = 58 N ₂ = 42	23,12	19,73	25,68	21,31	0,7 28		

Table A.5 (continued)

Gas family and group		Nature of gas	Designation	Composition Volume %	W_i MJ/m ³	H_i MJ/m ³	W_s MJ/m ³	H_s MJ/m ³	d	Test Pressure mbar	Country
Gases Linked to the second family	Group LL	Reference	G 25 ^{a)}	CH ₄ = 86 N ₂ = 14	37,38	29,25	41,52	32,49	0,6 12	p_n = 20 p_{min} = 18 p_{max} = 25	DE
		Incomplete combustion Sooting	G 26	CH ₄ = 80 C ₃ H ₈ = 7 N ₂ = 13	40,52	33,36	44,83	36,91	0,6 78		
		Flame lift	G 271	CH ₄ = 74 N ₂ = 26	30,94	25,17	34,36	27,96	0,6 62		
	Group S	Reference	G 25.1	CH ₄ = 86 CO ₂ = 14	35,25	29,30	39,11	32,51	0,6 91	p_n = 25	HU
		Incomplete combustion Sooting	G 26.1	CH ₄ = 80 C ₃ H ₈ = 6 CO ₂ = 14	37,61	32,60	41,58	36,04	0,7 51	p_{min} = 20 p_{max} = 33	
		Lift limit	G 27.1	CH ₄ = 82 CO ₂ = 18	32,70	27,94	36,29	31,00	0,7 30	02 p_n = 85 p_{min} = 73 p_{max} = 100	
Gases of the second family	Range Es of Group E	Reference	G 20 ^{a)}	CH ₄ = 100	45,67	34,02	50,72	37,78	0,5 55	p_n = 20 p_{min} = 17 p_{max} = 25	FR
		Incomplete combustion Sooting	G 21	CH ₄ = 87 C ₃ H ₈ = 13	49,60	41,01	54,76	45,28	0,6 84		
		Light back	G 222	CH ₄ = 77 H ₂ = 23	42,87	28,53	47,87	31,86	0,4 43		
	Range Ei of Group E	Lift limit	G 26	CH ₄ = 80 C ₃ H ₈ = 7 N ₂ = 13	40,52	33,36	44,83	36,91	0,6 78	p_n = 25 p_{min} = 20 p_{max} = 30	
		Reference Light back	G 25 ^{b)}	CH ₄ = 86 N ₂ = 14	37,38	29,25	41,52	32,49	0,6 12		
		Incomplete combustion Sooting	G 26	CH ₄ = 80 C ₃ H ₈ = 7 N ₂ = 13	40,52	33,36	44,83	36,91	0,6 78		
		Lift limit	G 231	CH ₄ = 85 N ₂ = 15	36,82	28,91	40,90	32,11	0,6 17		

a) Composition of the air (%): O₂ = 20,95; N₂ = 79,05.
b) For the characteristics of the reference gases G 20 and G 25, see Table 4.
c) Gases G 2.302 and G 1.251 have the same composition but different pressure.

A.6 Gas connections in the various countries

Table A.6 shows the national situations concerning the various types of gas connection specified in 5.1.6.

Table A.6 — Permitted inlet connections

Country	Category I ₃₊ , I _{3P} , I _{3B} , I _{3B/P}			Other categories		
	Threaded connections		Other connections	Threaded connections		Other connections
	EN 10226-1:2004 EN 10226-2:2005	EN ISO 228-1:2003		EN 10226-1:2004 EN 10226-2:2005	EN ISO 228-1:2003	
AT	Yes	—	Yes	Yes	—	—
BE	Yes	Yes	Yes	—	Yes	—
BG	—	—	—	—	—	—
CH	Yes	Yes	Yes	Yes	Yes	—
CY	—	—	—	—	—	—
CZ	—	—	—	—	—	—
DE	Yes	—	Yes	Yes	—	—
DK	Yes	Yes	Yes	—	Yes	—
EE	—	—	—	—	—	—
ES	—	—	—	—	—	—
FI	Yes	Yes	Yes	Yes	Yes	—
FR	—	Yes	Yes	—	Yes	—
GB	Yes ^{a)b)}	—	Yes	Yes ^{a)b)}	—	Yes
GR	Yes	—	Yes	Yes	—	—
HU	—	—	—	—	—	—
IE	Yes	—	Yes	Yes	—	Yes
IS	—	—	—	—	—	—
IT	Yes	—	Yes	Yes	—	—
LT	—	—	—	—	—	—
LU	—	—	—	—	—	—
LV	—	—	—	—	—	—
MT	—	—	—	—	—	—
NL	Yes	—	—	Yes	—	—
NO	Yes	Yes	Yes	—	—	—
PL	Yes ^{b)}	Yes	Yes	Yes ^{b)}	Yes	—
PT	Yes	Yes	Yes	Yes	Yes	Yes
RO	—	—	—	—	—	—
SE	—	—	—	—	—	—
SI	Yes	Yes	Yes	Yes	Yes	Yes
SK	—	—	—	—	—	—
a)	taper- taper threads					
b)	taper – parallel threads					

A.7 Flue connections in the various countries

Table A.7 shows the national situations concerning the diameters of standard flue pipes.

Table A.7 — Standard flue pipe diameters

Country	Standard flue pipe diameters (external) in mm																
AT	60	70	80	90	100	110	120	130	140	150	160	180	200				
BE	All diameters acceptable																
BG																	
CH	60	70	80	90	100	110	120	130	150	160	170	180	200				
CY																	
CZ																	
DE	60	70	80	90	100	110	120	130	150	200							
DK	Diameters not standardized																
EE																	
ES																	
FI	90	100	110	130	150	180	200										
FR	66	83	97	111	125	139	153	167	180								
GB	76	102	127	153	metal pipes (all 0, -1 tolerance)												
GR	60	70	80	90	100	110	120	130	150	180	200						
IE	76	102	127	153	metal pipes (all 0, -1 tolerance)												
	84	109	137	162	fibrous cement pipes (all ± 3 tolerance)												
IS																	
IT	60	80	100	110	120	150											
LT																	
LU																	
LV																	
MT																	
NL	60	70	80	90	100	110	130	150	180	200							
NO																	
PL	60	70	80	90	100	110	120	130	140	150	160	170	180	200	250	250	
PT	60	85	90	95	105	110	115	120	125	130	135	145	155	205	255	305	355
RO																	
SE																	
SI	60	70	80	90	100	110	120	130	140	150	160	180	200				
SK																	

Annex B (informative)

Equivalence rules⁹⁾

B.1 Conversion to categories within a restricted Wobbe index range

Any appliance belonging to one category may be categorized as an appliance belonging to another category covering a more restricted range of Wobbe index provided that the requirements 5.1.1, 5.2.2.2, 5.2.2.3 and 5.2.5 are satisfied, that its state of conversion corresponds to that of the country (or countries) of destination and that the information provided on the appliance corresponds to its adjustment.

In principle, this equivalence is recognized without the appliance having to be submitted to new tests.

However, supplementary tests may be necessary using the pressures and the test gases currently in force in the intended country (or countries) of destination:

- a) when the supply pressures are different in the country (or countries) for which the appliance has been tested from those in the intended country of destination; or
- b) when an appliance fitted with adjusters¹⁰⁾, even though sealed, has been tested under the conditions of the original category with test gases different from those of the country where it is to be sold; or
- c) when the requirements for regulators (see 5.2.5) with respect to the existing category differ from those of the new category.

In all cases these supplementary tests are at most those stated in 7.1.5.1.

EXAMPLE 1 An appliance in category I_{2E} for G 20 at 20 mbar may be categorized as an appliance in category I_{2H} for G 20 at 20 mbar without additional tests. If, however, the pressures are different, the tests specified in 6.1.5.1 shall be carried out, after changing the injectors, if necessary.

EXAMPLE 2 An appliance in category I_{2E+} for G 20 at 20 mbar may be categorized as an appliance in category I_{2H} for G 20 at 20 bar provided that it satisfies the corresponding tests specified in 7.1.5.1 after changing the injectors, if necessary, and after adjusting the regulator in accordance with 5.2.5.

B.2 Conversion to categories within an identical Wobbe index range

Any appliance belonging to one category may be categorized as an appliance belonging to another category covering an identical range of Wobbe index provided that the requirements 5.1.1, 5.2.2.2, 5.2.2.3 and 5.2.5 are satisfied, that its state of conversion corresponds to that of the country (or countries) of destination and that the information provided on the appliance corresponds to its adjustment.

In principle, this equivalence is recognized without the appliance having to be submitted to new tests.

⁹⁾ This annex does not apply to the POCEDS(chimneys).

¹⁰⁾ Throughout Annex B the word "adjuster" refers to gas rate adjusters and to fixed primary aeration adjusters as appropriate.

However, supplementary tests may be necessary using the pressures and the test gases currently in force in the intended country (or countries) of destination:

- a) when the supply pressures are different in the country (or countries) for which the appliance has been tested from those in the intended country of destination; or
- b) when an appliance fitted with adjusters, even though sealed, has been tested under the conditions of the original category with test gases different from those of the country where it is to be sold; or
- c) when the requirements for regulators (see 5.2.5) with respect to the existing category differ from those of the new category.

In all cases, these supplementary tests are at most those stated in 7.1.5.1.

EXAMPLE 1 An appliance in category I_{2E+} may be categorized as an appliance in category I_{2Esi} or I_{2Er} provided that it satisfies the tests specified in 7.1.5.1 for the test pressures and the test gases relating to category I_{2Esi} or I_{2Er} and with the corresponding injectors and adjustments. These adjustments shall take into account the requirements of 5.2.5.

EXAMPLE 2 An appliance in category I_{2Esi} or I_{2Er} may be categorized as an appliance in category I_{2E+} provided that it satisfies the tests specified in 7.1.5.1 for the test pressures corresponding to category I_{2E+} . In addition, any adjusters shall be locked and sealed in the appropriate positions, taking account the requirements of 5.2.5.

NOTE Where the intended country of destination is Belgium, account should be taken of the Special Conditions given in Annex D.

B.3 Conversion to categories within a wider Wobbe index range

An appliance belonging to one category may be categorized as an appliance in another category covering a wider range of Wobbe index if it complies with all the constructional requirements of the proposed new category.

In addition, the appliance shall be submitted to the tests specified in 7.1.5.1 using the test gases and test pressures for the proposed new category. Where appropriate, account shall be taken of the Special Conditions given in Annex D.

Annex C (informative)

A-deviations¹¹⁾

C.1 General

A-deviation: National deviation due to regulations, the alteration of which is for the time being outside the competence of the CEN/CENELEC member.

This European Standard falls under Directive 90/396/EEC on the approximation of the laws of Member States concerning gas appliances.

A-deviations in an EFTA country are **valid instead** of the relevant provisions of the European Standard in that country until they have been removed.

C.2 Switzerland

The Swiss law (Luftreinhalte-Verordnung, LRV) of 1985-12-16 (state on 1993-01-01) is applicable instead of the requirements of 5.1.5 and 5.2 regarding energy efficiency (chimney losses, standby losses) and emissions of CO and NO_x.

¹¹⁾ This annex does not apply to the POCEDS(chimneys).

Annex D (normative)

Special national conditions¹²⁾

D.1 Special national conditions

Special national conditions are National characteristics or practice that cannot be changed even over a long period (e.g. climatic conditions, electrical earthing conditions). If it affects harmonization, it forms part of the European Standard or Harmonization Document.

For the countries in which the relevant special national conditions apply these provisions are normative, for other countries they are informative.

D.2 Belgium

Appliances of categories I_{2E+}, I_{2E(R)B} and I_{2E(S)B} marketed in Belgium have to undergo a test for ignition, crosslighting and flame stability with the limit gas G 231 at the minimum pressure of 15 mbar.

D.3 Italy

Appliances of categories I_{3B/P}, II_{2H3B/P} and III_{1a2H3B/P} without pressure regulators marketed in Italy shall have successfully undergone a test for flame stability with the limit gas G 31 at the pressure of 45 mbar.

D.4 Poland

Appliances of categories with index 3B/P shall be tested with the test gases for 3B/P given in Table 7 but with the following pressures: $p_n = 37$ mbar, $p_{min} = 25$ mbar and $p_{max} = 45$ mbar.

Additional information for gases used in Poland for Table 9 - Percentage by volume of CO₂ (dry products of neutral combustion)

Designation of gas	G27	G 2.411	G 2.412	G 2.350	G 2.351	G 2.352	G 2.300	G 2.301	G 2.302 G 1.251	G 1.250	G 1.252
% (CO ₂) _N (neutral combustion)	11,5	11,6	11,3	11,2	11,3	11,1	11,0	11,1	10,8	10,7	10,5

¹²⁾ This annex does not apply to the POCEDS(chimneys)

Annex E (informative)

Identification of gas types in use in various countries¹³⁾

Table E.1 — Means of identification of gas types in use in various countries

Type of gas	G 110	G 120	G 130	G 150	G 20	G 25	G 30	G 31
Country code ^{b)}								
AT					Erdgas		Flüssiggas	
BE					Aardgas, Gaz naturel	Aardgas, Gaz naturel	Butaan, Butane	Propaan, Propane
BG								
CH			Propan-Luft Butan-Luft		Erdgas H		Butan	Propan
CY								
CZ								
DE					Erdgas E W _o (12,0 – 15,7) kWh/m ³ 0 °C	Erdgas LL W _o (10,0 – 13,1) kWh/m ³ 0 °C	Flüssiggas B/P Butan	Propan
DK	Bygas				Naturgas		F-Gas	F-Gas
EE								
ES	Gas manufacturado		Aire propanado	Aire metanado	Gas natural		Butano	Propano
FI					Maakaasu, Naturgas		Butaani, Butan	Propaani, Propan
Fr ^{a)}			Air propané/ Air butané		Gaz naturel Lacq	Gaz naturel Groningue	Butane	Propane
GB					Natural Gas		Butane	Propane
GR					Φυσικό Αέριο		Υγραέριο Μείγμα	Προπανιο
HU								
IE					Natural Gas		Butane	Propane
IS								
IT	Gas di Città				Gas naturale/ Gas metano		GPL	
LT								
LU								
LV								
MT								
NL						Aardgas	Butaan	Propaan
NO							Butan	Propan
PL								
PT					Gás Natural		Butano	Propano
SE								
SI					Zemeljski plin		Utekočinjeni naftni plin (UNP)	Butan Propan
SK								

a) The meaning of the symbol corresponding to the type of gas should be explained in detail in the technical instructions. Concerning the system and its packaging, if an additional marking is intended by the manufacturer to explain the symbol, this text should be in conformity with the description given in this table. In the case of pressure couples, the two descriptions of the family should be mentioned

b) See 8.1.5.4 for codes.

¹³⁾ This annex does not apply to the POCEDS(chimneys)

Annex F (informative)

National solutions for countries whose national bodies are Affiliate Members of CEN¹⁴⁾

- F.1 Categories listed in the body of the standard and marketed in different countries**
- F.2 Appliance supply pressures corresponding to the categories given in F.1**
- F.3 Special categories marketed nationally or locally**
- F.4 Gases and test pressures corresponding to the special categories given in F.3**

¹⁴⁾ This annex does not apply to the POCEDS(chimneys)

Annex G (informative)

Calculation of conversions of NO_x¹⁵⁾

Table G.1 — Conversion of the emission value of NO_x for first family gases

1x10 ⁻⁶ = 2,054 mg/m ³ (1x10 ⁻⁶ = 1cm ³ /m ³)		G 110	
		mg/kWh	mg/MJ
O ₂ = 0%	1x10 ⁻⁶ =	1,714	0,476
	1 mg/m ³ =	0,834	0,232
O ₂ = 3%	1x10 ⁻⁶ =	2,000	0,556
	1 mg/m ³ =	0,974	0,270

Table G.2 — Conversion of the emission value of NO_x for second family gases

1x10 ⁻⁶ = 2,054 mg/m ³ (1x10 ⁻⁶ = 1cm ³ /m ³)		G 20		G 25	
		mg/kWh	mg/MJ	mg/kWh	mg/MJ
O ₂ = 0%	1x10 ⁻⁶ =	1,764	0,490	1,797	0,499
	1 mg/m ³ =	0,859	0,239	0,875	0,243
O ₂ = 3%	1x10 ⁻⁶ =	2,059	0,572	2,098	0,583
	1 mg/m ³ =	1,002	0,278	1,021	0,284

Table G.3 — Conversion of the emission value of NO_x for third family gases

1x10 ⁻⁶ = 2,054 mg/m ³ (1x10 ⁻⁶ = 1cm ³ /m ³)		G 30		G 31	
		mg/kWh	mg/MJ	mg/kWh	mg/MJ
O ₂ = 0%	1x10 ⁻⁶ =	1,792	0,498	1,778	0,494
	1 mg/m ³ =	0,872	0,242	0,866	0,240
O ₂ = 3%	1x10 ⁻⁶ =	2,091	0,581	2,075	0,576
	1 mg/m ³ =	1,018	0,283	1,010	0,281

¹⁵⁾ This annex does not apply to the POCEDS(chimneys)

Annex H (informative)

An example of sampling plans

H.1 Sampling plans

H.1.1 General

In this example, sampling plans are selected from the tables published in ISO 2859-1.

H.1.2 Acceptable Quality Level (AQL)

In this example, the AQL is decided in relation to the nature of the inspection feature being controlled. For defects classed as Major, the sampling plan is based on an AQL of 4.0.

NOTE Classification of defects should be the responsibility of the person responsible for the manufacturing process.

H.1.3 The inspection level

The inspection level defines the relationship between the batch size and the sample size. In this example, all incoming goods are subjected to inspection level II.

H.1.4 Normal, tightened or reduced inspection

In this example, the normal inspection is used initially on all incoming materials, after which, the following rules apply:

- a) when ten successive batches have been accepted on original there can be a switch to reduced inspection. This should remain in operation until one batch is rejected, at which point normal inspection is resumed;
- b) when two out of any five successive batches have been rejected on original inspection, there can be a switch to tightened inspection. This should remain in operation until five successive batches have been accepted, at which point normal inspection is resumed.

H.1.5 Single, double, multiple or sequential sampling

Unless otherwise specified, all incoming material should be subjected to single sampling plans.

H.1.6 Batch quality

Once the first four variables have been decided, the sampling plan tables should indicate the amount of samples to be inspected for any given batch quantity.

All information regarding levels of inspection should be indicated where appropriate on the inspection records.

H.2 Inspection levels and procedures

H.2.1 Incoming material

In this example sample inspected to ISO 2859-1 using an AQL = 2,5, general inspection level II, single sampling plan for normal inspection incorporating the switching rules to tighten or reduce inspection if necessary. All mill certification should be checked against the relevant technical specification.

H.2.2 In-process aspects

For all dimensional aspects, an inspection feature should be introduced each time the material changes form during the process.

A first inspection should be implemented and verified by the setter or supervisor at each machine operation and from then on the operators should carry out each required dimensional check at a rate of four per batch – unrecorded, using go-no go gauges.

For the purposes of this example, this is supplemented by a beginning and end of shift full dimensional check by the line supervisor using measuring equipment. This is a record check, a register of all results being maintained.

H.2.3 Finished goods checks

At the end of the manufacturing process, each unit should be visually inspected for damage.

At the warehouse, once a week, the goods inwards inspector should randomly select four samples from a particular product range and subject each item to full dimensional checks. This should also be carried out to a formalised programme.

Annex ZA (informative)

Clauses of this European Standard addressing requirements or provisions of EU Directives

This European Standard has been prepared under a mandate given to CEN by the European Commission and the European Free Trade Association, and supports Essential Requirements of EU Directive 90/396/EEC on the approximation of the laws of Member States concerning gas appliances.

WARNING — Other requirements and other EU Directives may be applicable to the products falling within the scope of this standard.

The following clauses in Table ZA.1 of this standard are likely to support requirements of EU Directive 90/396/EEC.

Table ZA.1 — Identification form on the compliance of EN 778 with the essential requirements of the EU Directive 90/396/EEC on the approximation of the laws of Member States concerning gas appliances

Essential Requirement	Subject	Relevant Clauses in EN 778
1.	General conditions	↓
1.1	Safe design and construction	Whole standard
1.2	Instructions -installer -user Warning notices -appliance -packaging Official language	7.4.2 7.4.3 7.1, 7.3 7.2, 7.3 7.4.1
1.2.1	Installer's instructions contain: -Type of gas used -Gas supply pressure -Fresh air for combustion -Products dispersal -Forced draught burners	7.1.2, 7.2, 7.4.2 7.1.2, 7.2, 7.4.2 7.1.2, 7.2, 7.4.2 7.4.2 Not applicable
1.2.2	User instructions contain: -all instructions -restrictions on use	7.4.1, 7.4.3 7.4.2
1.2.3	Warning notices state: -type of gas -gas supply pressure -restrictions on use	7.1, 7.2, 7.4 7.1, 7.2, 7.4 7.1.3
1.3	Fittings -manual valves -regulators -multifunctional control -flame supervision device -automatic valves -automatic burner control systems -thermostats Instructions	4.2.4.2 4.2.5 4.2.6 4.4 4.2.7 4.2.8 4.9 Not applicable

Table ZA.1 (continued)

Essential Requirement	Subject	Relevant Clauses in EN 778
2.1	Fitness for purpose	4.1.2, 5.2.7
2.2	Properties of materials	Foreword, 1
3.1.1	Durability	4.1.2, 4.1.4, 5.2.7
3.1.2	Condensation	4.1.2
3.1.3	Explosion risk	4
3.1.4	Air/water penetration	Not applicable
3.1.5	Normal auxiliary energy fluctuation -appliance -controls	4.1.11, 5.2.5.1, 6.3.5.3 4.2.6, 4.2.7, 4.2.8, 4.4
3.1.6	Abnormal auxiliary energy fluctuation -appliance -controls	4.1.11, 5.2.5.1, 6.3.5.3 4.2.6, 4.2.7, 4.2.8, 4.4
3.1.7	Electrical hazards	4.1.10
3.1.8	Deformation	Not applicable
3.1.9	Safety/control device failure -gas circuit -regulators -multifunctional controls -automatic burner control systems -flame supervision device -automatic shut-off valves -thermostats/cut-off device -atmosphere sensing device -combustion products discharge safety s.	4.2.1 4.2.5 4.2.6 4.2.8 4.4 4.2.7 4.9 5.2.8 5.2.9
3.1.10	Overruling of safety devices	4.2.1
3.1.11	Pre-set adjuster protection	4.2.2.1
3.1.12	Levers and setting devices	4.2.4.2, 4.2.6
3.2.1	Gas leakage	4.1.6, 5.2.1.1
3.2.2	Gas release during ignition, re-ignition and extinction	4.4, 4.5, 4.6
3.2.3	Unburned gas accumulation	Not applicable
3.3	Ignition: ignition, re-ignition and cross-lighting	5.2.4.1.1, 6.2.2
3.4.1	Flame stability Harmful substances	5.2.4.2 5.2.5.1
3.4.2	Combustion products release	5.2.1.2
3.4.3	Combustion products release	4.1.7.3, 5.2.8, 5.2.9
3.4.4	Flueless domestic appliances	Not applicable
3.5	Rational use of energy	5.3
3.6.1	Floor etc. temperatures	5.2.3.2
3.6.2	Temperature of knobs/levers	5.2.3.1, 5.2.3.3
3.6.3	External parts	5.2.3.2
3.7	Foodstuffs and water	Not applicable
Annex II	Certification	Foreword, 1
Annex III	Data plate	7.1.2

Compliance with this standard provides one means of conforming with the specific essential requirements of the Directive concerned and associated EFTA regulations.

Annex ZB (normative)

Clauses of this European Standard addressing the provisions of the EU Construction Products Directive

ZB.1 Scope and relevant characteristics

This European Standard has been prepared under Mandate M105 “Chimneys, flues and specific products” given to CEN by the European Commission and the European Free Trade Association.

The clauses of this European Standard shown in this Annex meet the requirements of the mandate given under the EU Construction Products Directive (89/106/EEC).

Compliance with these clauses confers a presumption of fitness of the chimneys covered by this Annex for the intended uses indicated herein; reference shall be made to the information accompanying the CE marking.

WARNING — Other requirements and other EU Directives, not affecting the fitness for intended uses, can be applicable to the chimneys falling within the scope of this European Standard.

NOTE 1 In addition to any specific clauses relating to dangerous substances contained in this standard, there may be other requirements applicable to the products falling within its scope (e.g. transposed European legislation and national laws, regulations and administrative provisions). In order to meet the provisions of the EU Construction Products Directive, these requirements need also to be complied with, when and where they apply.

NOTE 2 An informative database of European and national provisions on dangerous substances is available at the Construction web site on EUROPA (accessed through http://ec.europa.eu/enterprise/construction/internal/dangsub/dangmain_en.htm).

This Annex establishes the conditions for the CE marking of the chimneys intended for the uses indicated in Table ZB.1 and shows the relevant clauses applicable:

This Annex has the same scope as Clause 1 of this standard and is defined by Tables ZB.1 and ZB.2

Table ZB.1 — Scope and relevant requirement clauses

Product: Metal system POCEDs as covered in clause 1 of this standard, except terminals and supports. Intended use: Single- and multi-wall POCEDs			
Essential Characteristics	Requirement clauses in this European Standard(s)	Levels and/or classes	Notes
Compressive strength	8.4.2	None	Manufacturer's declaration
Fire reaction	None	None	Not applicable ^a
Resistance to fire Soot fire resistance, integrity E and insulation I	None	None	Not applicable ^{b) c)}
Classification O and declaration of distance to combustible material	8.4.2	Oxx	Manufacturer's declaration of minimum distance to combustible material
	6.1.3.6	None	Pass/fail criteria
Gas tightness /leakage	6.1.1.2	None	Pass/fail criteria
Flow resistance	8.4.2	None	Manufacturer's declaration of minimum and maximum equivalent resistance
Thermal resistance/	None	None	Not applicable ^d
Dimensioning	8.4.2	None	Manufacturer's declaration
Thermal shock resistance	None	None	Not applicable ^b
Flexural tensile strength	5.1.7.2 8.4.2	None	Pass/ fail criteria. Manufacturer's declared value
Durability against chemicals	5.1.2 6.1.7	None	Pass-fail criteria
Durability against corrosion	5.1.2 6.1.7	None	Pass-fail criteria
Resistance to Freeze - thaw	None	None	Not applicable ^e
^a Fire reaction- No requirements for metal POCEDs. ^b Soot fire resistance G - is not applicable to gas-fired appliances. ^c Insulation I - is not required for metal POCEDs. Integrity E - is not required for metal POCEDs. ^d This characteristic is only relevant when it is required to match the chimney with the appliance. The Performance of the POCED is verified as part of the performance testing of the appliance. ^e This characteristic is only relevant to construction materials that absorb water. This standard only applies to appliances with metal POCEDs.			

Table ZB.2 — Scope and relevant requirement clauses

Product: Terminals as covered in Clause 1 of this standard			
Intended use: Single- and multi-wall POCEDs			
Essential Characteristics	Requirement clauses in this European Standard(s)	Levels and/or classes	Notes
Flow resistance	8.4.2	None	Manufacturers declaration.

The requirement on a certain characteristic is not applicable in those Member States (MSs) where there are no regulatory requirements on that characteristic for the intended use of the product. In this case, manufacturers placing their products on the market of these MSs are not obliged to determine nor declare the performance of their products with regard to this characteristic and the option “No performance determined” (NPD) in the information accompanying the CE marking (see ZB.3) may be used. The NPD option may not be used, however, where the characteristic is subject to a threshold level.

ZB.2 Procedure(s) for attestation of conformity of [construction products]

ZB.2.1 System(s) of attestation of conformity

The system(s) of attestation of conformity of the POCEDs indicated in Tables ZB.1 and ZB.2 in accordance with the Decision of the Commission 95/467/EC of 27-09-95 amended by the decisions 01/596/EC of 8th January 2001 and 2002/592/EC of 15th July 2002 and as given in Annex III of the mandate for “Chimneys, flues and specific products”, is shown in Table ZB.3 for the indicated intended use(s) and relevant level(s) or class(es).

Table ZB.3 — System(s) of attestation of conformity

Product(s)	Intended use(s)	Level(s) or class(es)	Attestation of conformity system(s)
Metal system chimney products	Chimneys	Any	2+
Terminals			4
System 2+: See Directive 89/106/EEC (CPD) Annex III.2.(ii), First possibility, including certification of the factory production control by an approved body on the basis of initial inspection of factory and of factory production control as well as of continuous surveillance, assessment and approval of factory production control.			
System 4: See Directive 89/106/EEC (CPD) Annex III.2.(ii), Third possibility			

The attestation of conformity of the POCEDs in Tables ZB.1 and ZB.1.2 shall be based on the evaluation of conformity procedures indicated in Tables ZB.4 and ZB.5 respectively resulting from application of the clauses of this or other European standard indicated therein.

Table ZB.4 — Assignment of evaluation of conformity tasks for chimneys under system 2+ in Table ZB.1

Tasks		Content of the task	Evaluation of conformity clauses to apply
Tasks under the responsibility of the manufacturer	Factory production control (FPC)	Parameters related to all relevant characteristics of Table ZB.1	9.3
	Initial type testing by the manufacturer	All relevant characteristics of Table ZB.1	9.2
	Possibly testing of samples taken at the factory	All relevant characteristics of Table ZB.1	9.3
Tasks of the Approved body	Certification of the FPC by the FPC certification body on the basis of :-	Initial inspection of factory and of FPC	9.3
		Continuous surveillance, assessment and approval of FPC	9.3

Table ZB.5 — Assignment of evaluation of conformity tasks for terminals under system 4 in Table ZB.2

Tasks		Content of the task	Evaluation of conformity clauses to apply
Tasks for the manufacturer	Factory production control (F.P.C)	Parameters related to all relevant characteristics of Table ZB.2	9.3
	Initial type testing	All relevant characteristics of Table ZB.2	9.2

ZB.2.2 EC Certificate and Declaration of conformity

When, in the case of products under system of conformity 2+, compliance with the conditions of this annex is achieved, and once the notified body has drawn up the certificate mentioned below, the manufacturer or his agent established in the EEA shall prepare and retain a declaration of conformity, which entitles the manufacturer to affix the CE marking. This declaration shall include:

- a) name and address of the manufacturer, or his authorised representative established in the EEA, and the place of production;

NOTE 1 The manufacturer may also be the person responsible for placing the product onto the EEA market, if he takes responsibility for CE marking.

- b) description of the product (type, identification, use, ...), and a copy of the information accompanying the CE marking;

NOTE 2 Where some information required for the declaration is already given in the CE marking information, it does not need to be repeated.

- c) provisions to which the product conforms (i.e. Annex ZB of this EN);
- d) particular conditions applicable to the use of the product (e.g. provisions for use under certain conditions);
- e) number of the accompanying factory production control certificate;
- f) name of, and position held by, the person empowered to sign the declaration on behalf of the manufacturer or his authorised representative.

The declaration shall be accompanied by a factory production control certificate, drawn up by the notified body, which shall contain, in addition to the information above:

- g) name and address of the notified body;
- h) number of the factory production control certificate;
- i) conditions and period of validity of the certificate, where applicable;
- j) name of, and position held by, the person empowered to sign the certificate.

The above mentioned declaration and certificate shall be presented in the official language or languages of the Member State in which the product is to be used.

When, in the case of products under system of conformity 4, compliance with the conditions of this Annex is achieved, the manufacturer or his agent established in the EEA shall prepare and retain a declaration of conformity (EC Declaration of conformity), which entitles the manufacturer to affix the CE marking. This declaration shall include:

- k) name and address of the manufacturer, or his authorised representative established in the EEA, and the place of production;

NOTE 3 The manufacturer may also be the person responsible for placing the product onto the EEA market, if he takes responsibility for CE marking.

- l) description of the product (type, identification, use, ...), and a copy of the information accompanying the CE marking;

NOTE 4 Where some information required for the declaration is already given in the CE marking information, it does not need to be repeated.

- m) provisions to which the product conforms (i.e. Annex ZB of this EN), and a reference to the ITT report(s) and factory production control records (if appropriate);
- n) particular conditions applicable to the use of the product (e.g. provisions for use under certain conditions);
- o) name of, and position held by, the person empowered to sign the declaration on behalf of the manufacturer or his authorised representative.

ZB.3 CE marking and labelling

The manufacturer or his authorised representative established within the EEA is responsible for the affixing of the CE marking.

The CE marking symbol to affix shall be in accordance with Directive 93/68/EC and shall be shown on the appliance Data Badge. The following information shall accompany the CE marking symbol and may be on the Data Badge, the packaging, in the appliance Installation instructions or as a separate insert with the appliance

instruction pack. Where it is not possible for this information to appear with the CE marking symbol on the appliance Data Badge, the CE marking symbol will be repeated at the head of the information (see Figure ZB.1):

- a) identification number of the certification body (only for products under systems 2+);

NOTE 1 The certification body is the “Notified Body” (notified under the CPD) responsible for the Factory Production Control Certificate (FPC certificate).

- b) name or identifying mark and registered address of the appliance manufacturer;
- c) the last two digits of the year in which the marking is affixed;
- d) number of the factory production control certificate (if relevant);
- e) reference to this European Standard.

Figure ZB.1 gives an example of the information to be given on the product, label, packaging and/or commercial documents.

 01234	<p><i>CE conformity marking, consisting of the “CE”-symbol given in directive 93/68/EEC.</i></p> <p><i>Identification number of the notified body</i></p>
AnyCo Ltd, PO Box 21, B-1050 05 01234-CPD-00234	<p><i>Name or identifying mark and registered address of the manufacturer</i></p> <p><i>Last two digits of the year in which the marking was affixed</i></p> <p><i>Certificate number</i></p>
EN 778 Metal POCED Distance to combustible materials: O25	<p><i>Number of European standard</i></p> <p><i>Definition of the product</i></p> <p><i>Information on mandated characteristics not included in the designation or threshold values to be given (see Table Zb.1)</i></p>

Figure ZB.1 — Example of CE marking information of a POCED

In addition to any specific information relating to dangerous substances shown above, the product should also be accompanied, when and where required and in the appropriate form, by documentation listing any other legislation on dangerous substances for which compliance is claimed, together with any information required by that legislation.

NOTE 2 European legislation without national derogations need not be mentioned.

NOTE 3 Affixing the CE marking symbol to a product means that it complies with all applicable directives.

Bibliography

- [1] ISO 2859-1, *Sampling procedures for inspection by attributes — Part 1: Sampling schemes indexed by acceptance quality limit (AQL) for lot-by-lot inspection*
- [2] EN 61558-2-6:1997, *Safety of power transformers, power supply units and similar — Part 2-6: Particular requirements for safety isolating transformers for general use (IEC 61558-2-6:1997)*

BSI - British Standards Institution

BSI is the independent national body responsible for preparing British Standards. It presents the UK view on standards in Europe and at the international level. It is incorporated by Royal Charter.

Revisions

British Standards are updated by amendment or revision. Users of British Standards should make sure that they possess the latest amendments or editions.

It is the constant aim of BSI to improve the quality of our products and services. We would be grateful if anyone finding an inaccuracy or ambiguity while using this British Standard would inform the Secretary of the technical committee responsible, the identity of which can be found on the inside front cover. Tel: +44 (0)20 8996 9000. Fax: +44 (0)20 8996 7400.

BSI offers members an individual updating service called PLUS which ensures that subscribers automatically receive the latest editions of standards.

Buying standards

Orders for all BSI, international and foreign standards publications should be addressed to Customer Services. Tel: +44 (0)20 8996 9001. Fax: +44 (0)20 8996 7001 Email: orders@bsigroup.com You may also buy directly using a debit/credit card from the BSI Shop on the Website <http://www.bsigroup.com/shop>

In response to orders for international standards, it is BSI policy to supply the BSI implementation of those that have been published as British Standards, unless otherwise requested.

Information on standards

BSI provides a wide range of information on national, European and international standards through its Library and its Technical Help to Exporters Service. Various BSI electronic information services are also available which give details on all its products and services. Contact Information Centre. Tel: +44 (0)20 8996 7111 Fax: +44 (0)20 8996 7048 Email: info@bsigroup.com

Subscribing members of BSI are kept up to date with standards developments and receive substantial discounts on the purchase price of standards. For details of these and other benefits contact Membership Administration. Tel: +44 (0)20 8996 7002 Fax: +44 (0)20 8996 7001 Email: membership@bsigroup.com

Information regarding online access to British Standards via British Standards Online can be found at <http://www.bsigroup.com/BSOL>

Further information about BSI is available on the BSI website at <http://www.bsigroup.com>.

Copyright

Copyright subsists in all BSI publications. BSI also holds the copyright, in the UK, of the publications of the international standardization bodies. Except as permitted under the Copyright, Designs and Patents Act 1988 no extract may be reproduced, stored in a retrieval system or transmitted in any form or by any means – electronic, photocopying, recording or otherwise – without prior written permission from BSI.

This does not preclude the free use, in the course of implementing the standard, of necessary details such as symbols, and size, type or grade designations. If these details are to be used for any other purpose than implementation then the prior written permission of BSI must be obtained.

Details and advice can be obtained from the Copyright and Licensing Manager. Tel: +44 (0)20 8996 7070 Email: copyright@bsigroup.com