

Multi-burner gas-fired overhead radiant tube heater systems for non- domestic use

Part 1: System D — Safety

ICS 97.100.20

National foreword

This British Standard is the UK implementation of EN 777-1:2009. It supersedes BS EN 777-1:1999 which is withdrawn.

The UK participation in its preparation was entrusted to Technical Committee GSE/20, Non-domestic space heaters (gas).

A list of organizations represented on this committee can be obtained on request to its secretary.

This publication does not purport to include all the necessary provisions of a contract. Users are responsible for its correct application.

Compliance with a British Standard cannot confer immunity from legal obligations.

This British Standard was published under the authority of the Standards Policy and Strategy Committee on 30 April 2009

© BSI 2009

ISBN 978 0 580 55843 6

Amendments/corrigenda issued since publication

Date	Comments

EUROPEAN STANDARD

EN 777-1

NORME EUROPÉENNE

EUROPÄISCHE NORM

March 2009

ICS 91.140.40

Supersedes EN 777-1:1999

English Version

Multi-burner gas-fired overhead radiant tube heater systems for non-domestic use - Part 1: System D - Safety

Tubes radiants suspendus à multi-brûleurs utilisant les
combustibles gazeux à usage non-domestique - Partie 1 :
Système D - Sécurité

Dunkelstrahlersysteme mit mehreren Brennern mit Gebläse
für gewerbliche und industrielle Anwendung - Teil 1:
System D - Sicherheit

This European Standard was approved by CEN on 24 January 2009.

CEN members are bound to comply with the CEN/CENELEC Internal Regulations which stipulate the conditions for giving this European Standard the status of a national standard without any alteration. Up-to-date lists and bibliographical references concerning such national standards may be obtained on application to the CEN Management Centre or to any CEN member.

This European Standard exists in three official versions (English, French, German). A version in any other language made by translation under the responsibility of a CEN member into its own language and notified to the CEN Management Centre has the same status as the official versions.

CEN members are the national standards bodies of Austria, Belgium, Bulgaria, Cyprus, Czech Republic, Denmark, Estonia, Finland, France, Germany, Greece, Hungary, Iceland, Ireland, Italy, Latvia, Lithuania, Luxembourg, Malta, Netherlands, Norway, Poland, Portugal, Romania, Slovakia, Slovenia, Spain, Sweden, Switzerland and United Kingdom.



EUROPEAN COMMITTEE FOR STANDARDIZATION
COMITÉ EUROPÉEN DE NORMALISATION
EUROPÄISCHES KOMITEE FÜR NORMUNG

Management Centre: Avenue Marnix 17, B-1000 Brussels

Contents

Page

Foreword.....	4
1 Scope.....	5
2 Normative references	5
3 Terms and definitions.....	6
3.1 System and its constituent parts	6
3.2 Adjusting, control and safety devices	9
3.3 System operation	10
3.4 Gases.....	13
3.5 Conditions of operation and measurement.....	14
3.6 Country of destination.....	15
4 Classification of systems	15
4.1 Classification according to the nature of the gases used (categories)	15
4.2 Classification according to the gases capable of being used	15
4.3 Classification according to the mode of evacuation of the combustion products.....	17
5 Constructional requirements	17
5.1 General.....	17
5.2 Requirements for adjusting, control and safety devices.....	22
5.3 Ignition devices	26
5.4 Main burners.....	27
5.5 Pressure test points.....	27
5.6 Injectors	27
6 Operational requirements	28
6.1 Soundness	28
6.2 Heat inputs.....	28
6.3 Limiting temperatures	28
6.4 Ignition, cross-lighting and flame stability.....	29
6.5 Pressure regulator	29
6.6 Combustion	29
6.7 Prolonged performance.....	30
6.8 Measurement of oxides of Nitrogen, NO _x	31
7 Test methods.....	31
7.1 General.....	31
7.2 Construction and design.....	38
7.3 Safety of operation.....	38
7.4 Other pollutants	50
8 Marking and instructions	53
8.1 Marking of the system and the packaging	53
8.2 Instructions.....	57
8.3 Presentation	61
9 Evaluation of conformity of POCEs and their associated terminals	61
9.1 General.....	61
9.2 Type testing	61
9.3 Factory production control (FPC)	62
Annex A (informative) National situations	64
A.1 General.....	64
A.2 Categories listed in the body of the standard and marketed in different countries	64
A.3 Appliance supply pressures corresponding to the categories given in A.2	66

A.4	Special categories marketed nationally or locally.....	68
A.5	Test gases corresponding to the special categories given in A.4.....	72
A.6	Gas connections in the various countries	73
A.7	Flue connections in the various countries.....	75
Annex B (informative)	System D	76
B.1	Type D systems.....	76
Annex C (informative)	Equivalence rules	78
C.1	Conversion to categories within a restricted Wobbe Index range	78
C.2	Conversion to categories within an identical Wobbe Index range	78
C.3	Conversion to categories within a wider Wobbe Index range.....	79
Annex D (informative)	Calculation of the mass flow rate of flue gases	80
D.1	Flue gas mass flow rate.....	80
D.2	Quantity of air in the flue gas	80
D.3	Flue gas excess air ratio (λ).....	81
D.4	Quantity of water vapour in the flue gas	81
D.5	Quantity of Nitrogen in the flue gas	81
D.6	Quantity of Oxygen in the flue gas.....	81
D.7	Dry quantity of flue gas	82
D.8	Quantity of carbon dioxide in the flue gas	82
Annex E (informative)	Identification of gas types in use in various countries	84
Annex F (normative)	Special national conditions	85
F.1	General.....	85
Annex G (informative)	Calculation example of the weighting factors for a system with several rates	86
G.1	Appliance rates	86
G.2	Weighting of $Q_{pi,\%} = 20$	86
G.3	Weighting of $Q_{pi,\%} = 40$	86
G.4	Weighting of $Q_{pi,\%} = 60$	86
G.5	Weighting of $Q_{pi,\%} = 70$	87
G.6	Total weighting.....	87
Annex H (informative)	Calculation of conversions of NO_x	88
H.1	NO_x emission conversion factors.....	88
H.2	NO_x Conversion — Calculation.....	89
Annex I (informative)	National situations of countries whose national bodies are CEN associate members.....	91
Annex J (informative)	An example of sampling plans	92
J.1	Sampling plans.....	92
J.2	Inspection levels and procedures	93
Annex K (informative)	Flue determination	94
K.1	General conditions of test.....	94
K.2	Test conditions.....	94
K.3	Test procedure	94
K.4	Accuracy of measurement	96
K.5	Calculation of Flue Loss.....	96
Annex ZA (informative)	Clauses of this European Standard addressing essential requirements or other provisions of EU Directives.....	99
Annex ZB (informative)	Clauses of this European Standard addressing the provisions of the EU Construction Products Directive	102
ZB.1	Scope and relevant characteristics.....	102
ZB.2	Procedure(s) for attestation of conformity of [construction products]	104
ZB.3	CE marking and labelling	107
Bibliography	109

Foreword

This document (EN 777-1:2009) has been prepared by Technical Committee CEN/TC 180 “Domestic and non-domestic gas fired air heaters and non-domestic gas fired overhead radiant heaters”, the secretariat of which is held by AFNOR.

This European Standard shall be given the status of a national standard, either by publication of an identical text or by endorsement, at the latest by September 2009, and conflicting national standards shall be withdrawn at the latest by September 2009.

Attention is drawn to the possibility that some of the elements of this document may be the subject of patent rights. CEN [and/or CENELEC] shall not be held responsible for identifying any or all such patent rights.

This document supersedes EN 777-1:1999.

This revision modifies EN 777-1:1999. It has been prepared to incorporate requirements for combustion products evacuation ducts, POCEs, supplied as an integral part of the system to support the EU Directive 89/106/EEC on construction products under mandate M/105. To this end the systems within the scope of this standard are now defined as Type B₅₂ rather than Type B₂₂.

Furthermore, the opportunity presented by this revision has been taken to update the standard in respect to EN 437:2003.

This document has been prepared under a mandate given to CEN by the European Commission and the European Free Trade Association, and supports essential requirements of EC Directive(s).

For relationship with EC Directive(s), see informative Annexes ZA and ZB, which are integral parts of this document.

According to the CEN/CENELEC Internal Regulations, the national standards organizations of the following countries are bound to implement this European Standard: Austria, Belgium, Bulgaria, Cyprus, Czech Republic, Denmark, Estonia, Finland, France, Germany, Greece, Hungary, Iceland, Ireland, Italy, Latvia, Lithuania, Luxembourg, Malta, Netherlands, Norway, Poland, Portugal, Romania, Slovakia, Slovenia, Spain, Sweden, Switzerland and the United Kingdom.

1 Scope

This European Standard specifies the requirements and test methods for the construction, safety, classification and marking of non-domestic gas-fired overhead radiant tube heaters incorporated into a multi-burner system (called system D and referred to in the body of the text as the "system") with each burner unit under the control of an automatic burner control system.

This standard is applicable to Type B₅₂ systems (see 4.3) intended for use in other than domestic dwellings, in which the supply of combustion air and/or the evacuation of the products of combustion is achieved by mechanical means.

This standard is not applicable to:

- a) systems designed for use in domestic dwelling;
- b) outdoor systems;
- c) systems of heat input in excess of 120 kW (based on the net calorific value of the appropriate reference test gas);
- d) systems having a draught diverter;
- e) systems having fully pre-mixed gas and air burners in which:
 - 1) either the gas and all the combustion air are brought together just before the level of the combustion zone; or
 - 2) the pre-mixing of the gas and all combustion air is carried out in a part of the burner upstream of the combustion zone;
- f) systems that are designed for continuous condensation within the flue system under normal operating conditions;
- g) systems having combustion products evacuation ducts that are non-metallic.

This standard is applicable to systems which are intended to be type tested. It also includes requirements concerning the evaluation of conformity, including factory production control, but these requirements only apply to POCEs and their associated terminals.

NOTE Requirements for systems which are not intended to be type tested would need to be subject to further consideration.

Requirements concerning the rational use of energy have not been included in this European Standard.

2 Normative references

The following referenced documents are indispensable for the application of this document. For dated references, only the editions cited applies. For undated references, the latest edition of the referenced document (including any amendments) applies.

EN 88-1:2007, *Pressure regulators and associated safety devices for gas appliances - Part 1: Pressure regulators for inlet pressures up to and including 500 mbar*

EN 126:2004, *Multifunctional controls for gas burning appliances*

EN 161:2007, *Automatic shut-off valves for gas burners and gas appliances*

EN 257, *Mechanical thermostats for gas-burning appliances*

EN 298:2003, *Automatic gas burner control systems gas burners and gas burning appliances with or without fans*

EN 437:2003, *Test gases - Test pressures - Appliance categories*

EN 10226-1:2004, *Pipe threads where pressure-tight joints are made on the threads – Part 1: Taper external threads and parallel internal threads - Dimensions, tolerances and designation*

EN 10226-2:2005, *Pipe threads where pressure tight joints are made on the threads – Part 2: Taper external threads and taper internal threads - Dimensions, tolerances and designation*

EN 60335-1:2002, *Household and similar electrical appliances – Safety - Part 1: General requirements*

EN 60335-2-102:2006, *Household and similar electrical appliances – Safety - Part 2-102: Particular requirements for gas, oil and solid-fuel burning having electrical connections*

EN 60529:1992, *Degrees of protection provided by enclosures (IP code)*

EN 60584-1:1995, *Thermocouples — Part 1: Reference tables*

EN 60584-2:1993, *Thermocouples — Part 2: Tolerances*

EN ISO 228-1:2003, *Pipe threads where pressure-tight joints are not made on the threads - Part 1: Dimensions, tolerances and designation (ISO 228-1:2000)*

EN ISO 3166-1:2006, *Codes for the representation of names of countries and their subdivisions – Part 1: Country codes (ISO 3166-1:2006)*

EN ISO 6976:2005, *Natural gas - Calculation of the calorific value, density, relative density and Wobbe index from composition (ISO 6976:1995 including Corrigendum 1:1997, Corrigendum 2:1997 and Corrigendum 3:1999)*

ISO 7005-1:1992, *Metallic flanges - Part 1: Steel flanges*

ISO 7005-2:1988, *Metallic flanges - Part 2: Cast iron flanges*

ISO 7005-3:1988, *Metallic flanges - Part 3: Copper flanges and composite flanges*

CR 1404:1994, *Determination of emissions from appliances burning gaseous fuels during type testing.*

3 Terms and definitions

For the purposes of this standard the following terms and definitions apply:

3.1 System and its constituent parts

3.1.1

overhead radiant tube heater

gas-fired appliance intended for installation above head level which is designed to heat the space beneath by radiation by means of a tube or tubes, heated by the internal passage of combustion products

3.1.2 multi-burner systems

those radiant tube heater systems which employ two or more burner units with each unit incorporating independent flame monitoring.

NOTE The units may be located in one or more sections of tubing. One or more fans may be used to assist in the evacuation of products of combustion or the supply of combustion air

System D: system in which individual units without fans are connected to a common duct with a fan. Only one burner unit is situated in each branch tube (see Annex B).

Two arrangements of system D are recognized:

- a) system D₁: having branched tubes which may be of such short length that the flame produced at the burner may extend into the common duct
- b) system D₂: having branched tubes of sufficient length that the flame produced at the burner cannot extend into the common duct

3.1.3 branch tube

for the purposes of this part, a tube in which only one burner unit is situated and which only contains the products of combustion generated by this burner

3.1.4 common duct

duct which receives products of combustion from two or more branch tubes for the purposes of evacuation to the outside

3.1.5 individual burner unit

unit comprising a main burner and, if appropriate, an ignition burner. In addition, such components as are necessary to ignite the burner(s), monitor the flame and control the gas supply to the burner(s) are included in the unit

3.1.6 inlet connection

part of the system intended to be connected to the gas supply

3.1.7 mechanical joint (mechanical means of obtaining soundness)

means of ensuring the soundness of an assembly of several (generally metallic) parts without the use of liquids, pastes, tapes, etc.

NOTE For example the following:

- a) metal to metal joints;
- b) conical joints;
- c) toroidal sealing rings ("O" rings);
- d) flat joints.

3.1.8 gas circuit

part of the burner unit that conveys or contains the gas between the burner unit gas inlet connection and the burner(s)

3.1.9

restrictor

device with an orifice, which is placed in the gas circuit so as to create a pressure drop and thus reduce the gas pressure at the burner to a predetermined value for a given supply pressure and rate

3.1.10

gas rate adjuster

component allowing an authorized person to set the gas rate of the burner to a predetermined value according to the supply conditions

NOTE 1 Adjustment can be progressive (screw adjuster) or in discrete steps (by changing restrictors).

NOTE 2 The adjusting screw of an adjustable regulator is regarded as a gas rate adjuster.

NOTE 3 The action of adjusting this device is called "adjusting the gas rate".

NOTE 4 A factory sealed gas rate adjuster is considered to be non-existent.

3.1.11

setting an adjuster

immobilizing a gas rate adjuster by such means as e.g. a screw after the gas rate has been adjusted by the manufacturer or installer

3.1.12

sealing an adjuster

term applied to any arrangement in respect of the adjuster such that any attempt to change the adjustment breaks the sealing device or sealing material and makes this interference apparent

NOTE A factory sealed adjuster, i.e. an adjuster sealed by the system manufacturer, is considered to be non-existent.

A regulator is considered to be non-existent if it has been factory sealed, i.e. by the system manufacturer in a position such that it is not operational in the range of the normal supply pressure corresponding to the system category.

3.1.13

putting an adjuster or a control out of service

adjuster or a control (of temperature, pressure, etc.) is said to be "put out of service" if it is put out of action and sealed in this position. The burner unit then functions as if this device has been removed

3.1.14

injector

component that admits the gas into a burner

3.1.15

main burner

burner that is intended to ensure the thermal function of the system and is generally called the burner

3.1.16

ignition device

means (e.g. flame, electrical ignition device or other device) used to ignite the gas at the ignition burner or at the main burner

NOTE This device can operate intermittently or permanently.

3.1.17

ignition burner

burner whose flame is intended to ignite another burner

3.1.18

primary aeration adjuster

device enabling the primary air to be set at the desired value according to the supply conditions

3.1.19

combustion products circuit

circuit consisting of:

3.1.19.1

combustion chamber

enclosure inside which combustion of the air-gas mixture takes place

3.1.19.2

flue outlet

part of a Type B system that connects with a flue to evacuate the products of combustion

3.1.19.3

draught diverter

device placed in the combustion products circuit to reduce the influence of flue-pull and that of down-draught on the burner performance and combustion

3.1.19.4

POCED

combustion products evacuation duct that is intended to be used only with a specific appliance/system; this duct being either supplied with the appliance/system or specified in the manufacturer's instructions

3.1.20

range-rating device

component on the burner unit intended to be used by the installer to adjust the heat input of the burner unit, within a range of heat inputs stated by the manufacturer, to suit the actual heat requirements of the installation

This adjustment may be progressive (e.g. by use of a screw adjuster) or in discrete steps (e.g. by changing restrictors).

3.1.21

zero regulator

device which maintains a specified downstream pressure between it and a gas orifice at zero pressure within fixed limits independent of variation within a given range of upstream pressure and negative pressure downstream of the gas orifice

3.2 Adjusting, control and safety devices

3.2.1

automatic burner control system

system comprising at least a programming unit and all the elements of a flame detector device

The various functions of an automatic burner control system may be in one or more housings.

3.2.2

programming unit

device which reacts to signals from control and safety devices, gives control commands, controls the start-up sequence, supervises the burner operation and causes controlled shut-down, and if necessary safety shut-down and lock-out.

NOTE The programming unit follows a predetermined sequence of actions and always operates in conjunction with a flame detector device

3.2.3

programme

sequence of control operations determined by the programming unit involving switching on, starting up, supervising and switching off the burner

3.2.4

flame detector

device by which the presence of a flame is detected and signalled

NOTE It can consist of a flame sensor, an amplifier and a relay for signal transmission. These parts, with the possible exception of the actual flame sensor, may be assembled in a single housing for use in conjunction with a programming unit.

3.2.5

flame signal

signal given by the flame detector device, normally when the flame sensor senses a flame

3.2.6

flame simulation

condition which occurs when the flame signal indicates the presence of a flame when in reality no flame is present

3.2.7

pressure regulator¹

device which maintains the outlet pressure constant independent of the variations in inlet pressure within defined limits

3.2.8

adjustable pressure regulator

regulator provided with means for changing the outlet pressure setting

3.2.9

flame supervision device

device that, in response to a signal from the flame detector, keeps the gas supply open and shuts it off in the absence of the supervised flame

3.2.10

automatic shut-off valve

device that automatically opens, closes or varies the gas rate on a signal from the control circuit and/or the safety circuit

3.3 System operation

3.3.1

heat input

Q

quantity of energy used in unit time corresponding to the volumetric or mass flow rates: the calorific value used being the net or gross calorific value

NOTE The heat input is expressed in kilowatts (kW) [EN 437:2003].

3.3.2

nominal heat input

Q_n

value of the heat input (kW) declared by the manufacturer

¹ The term "regulator" is used in this case and for a volume regulator.

3.3.3
volume flow rate (V)

V

volume of gas consumed by the appliance in unit time during continuous operation

NOTE The volume flow rate is expressed in m³/h, l/min, dm³/h or dm³/s [EN 437:2003].

3.3.4
mass flow rate

M

mass of gas consumed by the appliance in unit time during continuous operation

NOTE The mass flow rate is expressed in kg/h or g/h [EN 437:2003].

3.3.5
flame stability

characteristic of flames which remain on the burner ports or in the flame reception zone intended by the construction

3.3.6
flame lift

total or partial lifting of the base of the flame away from the burner port or the flame reception zone provided by the design

Flame lift may cause the flame to blow out, i.e. extinction of the air-gas mixture.

3.3.7
light-back

entry of a flame into the body of the burner

3.3.8
light-back at the injector

ignition of the gas at the injector, either as a result of light-back into the burner or by the propagation of a flame outside the burner

3.3.9
sooting

phenomenon appearing during incomplete combustion and characterized by deposits of soot on the surfaces or parts in contact with the combustion products or with the flame

3.3.10
yellow tipping

yellowing of the tip of the blue cone of an aerated flame

3.3.11
purge

forced introduction of air through the combustion chamber and flue passages in order to displace any remaining fuel/air mixture and/or products of combustion

- a) pre-purge: the purge which takes place between the start signal and the energizing of the ignition device
- b) post-purge: the purge which takes place immediately following shut-down

3.3.12

first safety time²

interval between the ignition burner valve, start gas valve or main gas valve, as applicable, being energized and the ignition burner valve, start gas valve or main gas valve, as applicable, being de-energized if the flame detector signals the absence of a flame at the end of this interval

3.3.13

second safety time

where there is a first safety time applicable to either an ignition burner or start gas flame only, the second safety time is the interval between the main gas valve being energized and the main gas valve being de-energized if the flame detector signals the absence of a flame at the end of this interval

3.3.14

extinction safety time

time which elapses between the moment when the supervised flame is extinguished and the moment when the automatic burner control system initiates shut-down of the burner by removing power to the automatic gas shut-off valves

3.3.15

start-gas flame

flame established at the start-gas rate either at the main burner or at a separate ignition burner

3.3.16

running condition of the system

condition in which the burner is in normal operation under the supervision of the programming unit and its flame detector device

3.3.17

controlled shut-down

process by which the power to the gas shut-off valve(s) is removed immediately, e.g. as a result of the action of a controlling function

3.3.18

safety shut-down

process which is effected immediately following the response of a safety control or sensor or the detection of a fault in the burner control system and which puts the burner unit out of operation by immediately removing the power to the gas shut-off valve(s) and the ignition device

3.3.19

non-volatile lock-out

safety shut-down condition of the burner unit, such that a restart can only be accomplished by a manual reset of the burner unit and by no other means

3.3.20

volatile lock-out

safety shut-down condition of the burner unit, such that a restart can only be accomplished by either the manual reset of the burner unit, or a failure of the mains electrical supply and its subsequent restoration

3.3.21

spark restoration

process by which, following the loss of the flame signal, the ignition device will be switched on again without the total interruption of the gas supply

² Where there is no second safety time, this is called the safety time.

NOTE This process ends with the restoration of the running condition or, if there is no flame signal at the end of the safety time, with volatile or non-volatile lockout.

3.3.22

automatic recycling

process by which, after a safety shut-down, a full start up sequence is automatically repeated

NOTE This process ends with the restoration of the running condition or, if there is no flame signal at the end of the safety time, or if the cause of the accidental interruption has not disappeared, with volatile or non-volatile lock out.

3.4 Gases

3.4.1

calorific value

quantity of heat produced by the complete combustion, at a constant pressure equal to 1 013,25 mbar, of a unit volume or mass of gas, the constituents of the combustible mixture being taken at reference conditions and the products of combustion being brought back to the same conditions

A distinction is made between:

- a) the gross calorific value H_s in which the water produced by combustion is assumed to be condensed
- b) the net calorific value H_i in which the water produced by combustion is assumed to be in the vapour state

NOTE The calorific value is expressed:

- 1) either in MJ/m³ of dry gas at the reference conditions; or
- 2) in MJ/kg of dry gas [EN 437:2003].

3.4.2

relative density

d

ratio of the masses of equal volumes of dry gas and dry air at the same conditions of temperature and pressure

3.4.3

Wobbe index

gross Wobbe index: W_s and net Wobbe index: W_i .

ratio of the calorific value of a gas per unit volume and the square root of its relative density under the same reference conditions. The Wobbe index is said to be gross or net according to whether the calorific value used is the gross or net calorific value

NOTE The Wobbe index is expressed either in MJ/m³ of dry gas at the reference conditions or in MJ/kg of dry gas [EN437:2003].

3.4.4

test pressure

gas pressures used to verify the operational characteristics of appliances using combustible gases. They consist of normal and limit pressures

NOTE Test pressures are expressed in mbar). 1 mbar = 10² Pa [EN 437:2003].

**3.4.5
normal pressure**

p_n

pressure under which the appliances operate in nominal conditions when they are supplied with the corresponding reference gas

[EN 437:2003]

**3.4.6
limit pressure**

maximum limit pressure p_{max} and minimum limit pressure p_{min}

pressures representative of the extreme variations in the appliance supply conditions

[EN 437:2003]

**3.4.7
pressure couple**

combination of two distinct gas distribution pressures applied by reason of the significant difference existing between the Wobbe indices within a single family or group in which :

- a) the higher pressure corresponds only to gases of low Wobbe index
- b) the lower pressure corresponds to gases of high Wobbe index

3.5 Conditions of operation and measurement

**3.5.1
reference conditions**

in this standard the following reference conditions apply:

- a) for calorific values, temperature: 15 °C;
- b) for gas and air volumes dry, brought to 15 °C and to an absolute pressure of 1 013,25 mbar.

**3.5.2
cold condition**

condition of the installation required for some tests and obtained by allowing the unlit burner unit to attain thermal equilibrium at room temperature

**3.5.3
hot condition**

condition of the installation required for some tests and obtained by heating to thermal equilibrium at the nominal heat input

**3.5.4
equivalent resistance**

resistance to flow in millibar, measured at the outlet of the system, which is equivalent to that of the actual flue

**3.5.5
thermal equilibrium**

operating state of the system corresponding to a particular setting of the input in which the flue gas temperature does not change by more than ± 2 % (in °C) over a period of 10 min

3.6 Country of destination

3.6.1

direct country of destination

country for which the system has been certified and which is specified by the manufacturer as the intended country of destination. At the time of putting the system on the market and/or installation, the system shall be capable of operating, without adjustment or modification, with one of the gases distributed in the country concerned, at the appropriate supply pressure

More than one country can be specified if the system, in its current state of adjustment, can be used in each of these countries.

3.6.2

indirect country of destination

country for which the system has been certified, but for which, in its present state of adjustment, it is not suitable. Subsequent modification or adjustment shall be made in order that it can be utilized safely and correctly in this country

4 Classification of systems

4.1 Classification according to the nature of the gases used (categories)

Gases are classified into three families, possibly divided into groups according to the value of the Wobbe index. Table 1 specifies the families and groups of gas used in this standard.

Table 1 — Gas classification

Gas family	Gas Group	Gross Wobbe index (MJ/m ³) at 15 °C and 1 013, 25 mbar	
		Minimum	Maximum
First	A	22,4	24,8
Second		39,1	54,7
	H	45,7	54,7
	L	39,1	44,8
	E	40,9	54,7
Third		72,9	87,3
	B/P	72,9	87,3
	P	72,9	76,8
	B	81,8	87,3

4.2 Classification according to the gases capable of being used

4.2.1 Category I: systems of category I are designed exclusively for the use of gases of a single family or of a single group.

- a) Systems designed for use on first family gases only:

Category I_{1a}: systems using only gases of Group A of the first family at the prescribed pressure (this category is not used).

- b) Systems designed for use on second family gases only:

Category I_{2H}: systems using only gases of Group H of the second family at the prescribed supply pressures.

Category I_{2L}: systems using only gases of Group L of the second family at the prescribed pressures.

Category I_{2E}: systems using only gases of Group E of the second family at the prescribed pressures.

Category I_{2E+}: systems using only gases of Group E of the second family, and operating with a pressure couple without adjustment on the system. The system gas regulator, if it exists, is not operative in the range of the two normal pressures of the pressure couple.

c) Systems designed for use on third family gases only:

Category I_{3B/P}: systems capable of using the third family gases (propane and butane) at the prescribed supply pressure.

Category I₃₊: systems capable of using the third family gases (propane and butane) and operating with a pressure couple without adjustment of the system. However, for certain types of system specified in the particular standards adjustment of the primary combustion air may be permitted when changing from propane to butane and vice versa. No gas pressure regulating device is permitted on the system.

Category I_{3P}: systems using only gases of Group P of the third family (propane) at the prescribed pressure.

4.2.2 Category II: systems of category II are designed for use on gases of two families.

a) Systems designed for use on gases of the first and second families:

Category II_{1a2H}: systems capable of using gases of Group a of the first family and gases of Group H of the second family. The first family gases are used under the same conditions as for category I_{1a}. The second family gases are used under the same conditions as for category I_{2H}.

b) Systems designed for use on gases of the second and third families:

Category II_{2H3B/P}: systems capable of using gases of Group H of the second family and gases of the third family. The second family gases are used under the same conditions as for category I_{2H}. The third family gases are used under the same conditions as for category I_{3B/P}.

Category II_{2H3+}: systems capable of using gases of Group H of the second family and gases of the third family. The second family gases are used under the same conditions as for category I_{2H}. The third family gases are used under the same conditions as for category I₃₊.

Category II_{2H3P}: systems capable of using gases of Group H of the second family and gases of Group P of the third family. The second family gases are used under the same conditions as for category I_{2H}. The third family gases are used under the same conditions as for category I_{3P}.

Category II_{2L3B/P}: systems capable of using gases of Group L of the second family and gases of the third family. The second family gases are used under the same conditions as for category I_{2L}. The third family gases are used under the same conditions as for category I_{3B/P}.

Category II_{2L3P}: systems capable of using gases of Group L of the second family and gases of Group P of the third family. The second family gases are used under the same conditions as for category I_{2L}. The third family gases are used under the same conditions as for category I_{3P}.

Category II_{2E3B/P}: systems capable of using gases of Group E of the second family and gases of the third family. The second family gases are used under the same conditions as for category I_{2E}. The third family gases are used under the same conditions as for category I_{3B/P}.

Category II_{2E+3+}: systems capable of using gases of Group E of the second family and gases of the third family. The second family gases are used under the same conditions as for category I_{2E+}. The third family gases are used under the same conditions as for category I₃₊.

Category II_{2E+3P}: systems capable of using gases of Group E of the second family and gases of the third family. The second family gases are used under the same conditions as for category I_{2E+}. The third family gases are used under the same conditions as for category I_{3P}.

4.2.3 Category III: systems of Category III are designed for use on gases of the three families.

This category is not in general use.

Categories III Systems which are in use in certain countries are given in Annex A (see A.3).

4.3 Classification according to the mode of evacuation of the combustion products

4.3.1 General

Systems are classified into several types according to the method of evacuation of the combustion products and admission of the combustion air.

4.3.2 Type B

A system intended for connection to a flue which evacuates the products of combustion to the outside of the room containing the system. The combustion air is drawn directly from the room.

This standard applies to:

- a) Type B₅: a Type B appliance, without a draught diverter, that is designed for connection via its flue duct to its flue terminal.

For systems in which the combustion air is supplied and/or in which the products of combustion are evacuated by mechanical means, two types are identified:

- b) Type B₅₂: a Type B₅ system incorporating a fan downstream of the combustion chamber/heat exchanger (this type is covered by this standard);
- c) Type B₅₃: a Type B₅ system incorporating a fan upstream of the combustion chamber/heat exchanger (this type is not covered by this standard).

5 Constructional requirements

5.1 General

5.1.1 Conversion to different gases

The only acceptable operations when converting from a gas of one group or family to a gas of another group or family and/or to adapt to different gas distribution pressures are given below for each category.

It is recommended that these operations should be possible without disconnecting the system.

5.1.1.1 Category I

- a) Categories I_{2H}, I_{2L}, I_{2E}, I_{2E+}: no modification to the system;

- b) Category I_{3B/P}: no modification to the system;
- c) Category I₃₊: replacement of injectors or calibrated orifices but only in order to convert from one pressure couple to another (e.g. 28–30/37 mbar to 50/67 mbar);
- d) Category I_{3P}: no modification to the system relative to a change of gas. For changing pressure, replacement of injectors and adjustment of gas rates.

5.1.1.2 Category II

5.1.1.2.1 Categories of systems designed for use with gases of the first and second families

Adjustment of the gas rate with, if necessary, a change of injector, restrictor or regulator.

Adjustment of the gas rate of the ignition burner, either by using an adjuster or by a change of injector or restrictor and, if necessary, a change of the complete ignition burner or of some of its parts.

Putting the regulator out of service under the conditions of 5.2.6.

Putting the gas rate adjuster(s) out of service under the conditions given in 5.2.1 and 5.2.2 if applicable.

The adjustments or component changes are only acceptable when converting from a gas of the first family to a gas of the second family or vice versa.

5.1.1.2.2 Categories of systems designed for use with gases of the second and third families

Adjustment of the gas rate with, if necessary, a change of injector, restrictor or regulator.

Adjustment of the gas rate of the ignition burner, either by using an adjuster or by a change of injector or restrictor and if necessary, a change of the complete ignition burner or of some of its parts.

Putting the regulator out of service under the conditions of 5.2.6.

Putting the gas rate adjuster(s) out of service under the conditions given in 5.2.1 and 5.2.2 if applicable.

The adjustments or component changes are only acceptable when:

- a) converting from a gas of the second family to a gas of the third family or vice versa;
- b) converting from one butane/propane pressure couple to another (e.g. 28–30/37 mbar to 50/67 mbar).

5.1.1.3 Category III

Category III systems which are in use in certain countries are given in Annex A (see A.3.2.3).

5.1.2 Materials and method of construction

The quality and thickness of materials used in the construction of a system including its POCED shall be:

- a) such that the construction and performance characteristics are not altered so as to affect the safe operation of the system in normal conditions of use and of maintenance by the user;
- b) such as to ensure a reasonable operating life.

In particular, when the system is installed according to the manufacturer's instructions, all the components shall withstand the mechanical, chemical and thermal conditions to which they may be subjected when used in a manner which can be reasonably foreseen.

Copper shall not be used for gas carrying parts where the temperature is likely to exceed 100 °C.

Asbestos or materials containing asbestos shall not be used.

Solder that has a melting point below 450 °C after application shall not be used for gas-carrying parts.

5.1.3 Accessibility for maintenance and use

Components and controls shall be arranged such that any adjustment, maintenance or exchange is easy without removing the radiant tube from the installed position. Where necessary, access doors or removable panels shall be provided.

Parts that are intended to be removable for maintenance or cleaning shall be readily accessible, shall be simple to assemble correctly and difficult to assemble incorrectly. Such parts shall be difficult to assemble incorrectly where incorrect assembly would create a hazardous condition or result in damage to the system and its controls.

Parts of the system which are not intended to be removed by the user and for which removal would affect safety shall be capable of removal only with the aid of tools.

5.1.4 Means of sealing

5.1.4.1 Soundness of the gas circuit

Holes for screws, studs, etc. intended for the assembly of components shall not open into the gasways. The wall thickness between holes (including threads) and gasways shall be not less than 1 mm.

The soundness of components and assemblies connected to the gas circuit and likely to be dismantled for routine maintenance at the consumer's premises shall be assured by means of mechanical joints, (e.g. metal to metal joints, O-ring joints or packing) but excluding the use of any sealing compound such as tape, mastic or paste. The soundness shall be maintained after dismantling and re-assembly.

Sealing compounds may be used for permanent threaded assemblies. The sealing material shall remain effective under normal conditions of system use.

5.1.4.2 Soundness of the combustion circuit

The soundness of the combustion circuit of the system shall be effected by mechanical means only, with the exception of those parts which do not require to be disconnected for routine maintenance, and which may be joined with mastic or paste in such a way that permanent soundness is assured under normal conditions of use (see 8.2.2.1 c).

5.1.5 Supply of combustion air and evacuation of combustion products

5.1.5.1 Air inlets

All openings for the supply of air into the system shall be adequately protected against inadvertent blockage. In addition, such openings shall not permit the entry of a ball of 16 mm diameter applied with a force of 5 N. The cross-section of the air passageway(s) shall not be adjustable.

5.1.5.2 Combustion circuit

The cross section of the combustion circuit shall be adjustable by means of one or more dampers to permit individual sections of the system to be adjusted within prescribed limits of suction in the combustion circuit, as declared by the manufacturer for the correct operation of the system.

Each damper shall be supplied by the manufacturer and once adjusted shall be capable of being locked and sealed in position.

With the damper in its fully closed position, there shall be at least 2 % of the cross-sectional area of the tube open to permit the venting of any gas build up.

5.1.5.3 Flue outlet

The POCED shall either be supplied with the appliance by the manufacturer or specified in the manufacturer's instructions. The specification shall include a description of the duct including any bends, its materials of construction and any critical tolerances (e.g. in length, diameter, thickness, insertion depth).

The manufacturer shall state the minimum and maximum equivalent resistance. The manufacturer's instructions shall give details for calculating the equivalent resistance (e.g. the allowance to be made for bends).

Where the appliance is intended to be fitted to a flue having a wall termination, the manufacturer shall either supply a flue terminal or state the type of termination which shall be used. The design of this shall be such that it will not allow entry of a ball of 16 mm diameter applied with a force of 5 N.

If the POCED is capable of being installed in accordance with the manufacturer's instructions such that its outlet, when fitted with any terminal supplied with the appliance, or specified in the manufacturer's instructions, extends beyond the external surface of a building by more than 1,5 m, this duct shall not undergo any permanent distortion when subjected to the wind load test specified in 4.3.2 of EN 1859:2000.

5.1.6 Inlet connections

The burner unit inlet connection shall be one of the following types:

- a) a thread conforming to EN ISO 228-1:2003. In this case the end of the gas inlet connection shall have a flat annular surface at least 3 mm wide for thread sizes 1/2 and 3/8 and at least 2,5 mm wide for thread size 1/4, to allow the interposition of a sealing washer. Moreover, when the end of the gas inlet connection has a thread of nominal size 1/2, it shall be possible to insert a gauge of 12,3 mm diameter to a depth of at least 4 mm;
- b) thread conforming to EN 10226-1:2004 or EN 10226-2:2005;
- c) a compression fitting suitable for copper tube;
- d) a straight tube at least 30 mm long, the end of which is cylindrical, smooth and clean, to allow connection by means of a compression fitting as specified in 5.1.6 c);
- e) a flange to ISO 7005-1:1992, ISO 7005-2:1988 or ISO 7005-3:1988.

NOTE The conditions of inlet connections prevailing in the various countries are given in A.5.

The gas inlet connection shall be so secured that connections to the gas supply can be made without disturbing any controls or gas-carrying components of the system.

5.1.7 Confirmation of operation

On each burner unit means shall be provided to allow observation of any ignition burner flame during commissioning and servicing. If the means of observation is a viewing port, it shall, when located in an area of high temperature, be covered with heat resistant glass or equivalent material and sealed with a suitable heat resistant sealant.

It shall at all times be possible for the user to ascertain visually whether a burner unit is in operation or has gone to volatile or non-volatile lock-out where:

- a) mirrors or windows are used, their optical properties shall not have deteriorated at the completion of all the tests specified in this standard;
- b) indicator lights are used their purpose shall be clearly and permanently identified on the system, or on the plate or label required by 8.1.2. The indicator lighting circuitry shall be so designed and arranged that:
 - 1) it indicates when a supervised flame is present and, in the case of a supervised ignition burner, it also indicates when the main burner is in operation;
 - 2) any failure arising in the indicator lighting circuitry shall either not affect the operation of any safety device or prevent the operation of the system.

5.1.8 Electrical equipment

The electrical equipment of the system shall be so designed and constructed as to obviate hazards of electrical origin and shall comply with the requirements of EN 60335-2-102:2006 which cover such hazards.

If the system is fitted with electronic components or electronic systems providing a safety function, these shall comply with the relevant requirements of EN 298:2003 with regard to electromagnetic compatibility immunity levels.

If the manufacturer specifies the nature of the electrical protection of the system on the data plate, this specification shall comply with EN 60529:1992:

- a) to give the degree of personal protection against contact with dangerous electrical components inside the system case;
- b) to give the degree of electrical protection, inside the system case, against harmful actions due to water penetration.

5.1.9 Operational safety in the event of fluctuation, interruption and restoration of the auxiliary energy

Interruption and subsequent restoration of the electricity supply at any time during the starting up or operation of the system shall result in the continued safe operation, volatile lock-out, non-volatile lock-out, or safety shut-down followed by automatic recycling.

Interruption and subsequent restoration of the electricity supply shall not override any "lock-out" condition except where the system is intended to be reset by means of switching off and on the electricity supply to the system, e.g. volatile lock-out. Such re-setting shall only be possible if any interruption and subsequent restoration of the electricity supply cannot give rise to a hazardous system condition.

NOTE Requirements relating to the continued and safe operation of the system in the event of normal and abnormal fluctuation of auxiliary energy is specified in 6.6.1 d).

5.1.10 Motors and fans

The direction of rotation of motors and fans shall be clearly marked.

Belt drives, where used, shall be so designed or positioned as to afford protection to the operator.

Means shall be provided to facilitate adjustment of belt tension. Access to such means shall be possible only with the use of commonly available tools.

Motors and fans shall be mounted in such a way as to minimize noise and vibration.

Lubrication points, if provided, shall be readily accessible.

5.2 Requirements for adjusting, control and safety devices

5.2.1 General

The functioning of any safety device shall not be overruled by that of any control device.

The system shall not incorporate any controls which need to be manipulated by the user when the system is in normal operation.

5.2.2 Gas rate adjusters

Systems in categories I_{2H}, I_{2L}, I_{2E}, I_{2E+}, I_{3B/P}, I_{3P}, II_{2H3B/P}, II_{2H3+}, II_{2H3P}, II_{2L3B/P}, II_{2E3B/P}, II_{2E+3+}, and II_{2E+3P} shall not be fitted with a gas rate adjuster. However, regulated systems in all of these categories except II_{2E+3+} may have a gas rate adjuster consisting of an adjusting screw on the gas regulator.

Systems in category II_{1a2H} shall have a gas rate adjuster for first family gases.

For systems in category II_{2H3+} having a gas rate adjuster, it shall be possible to put these devices out of service when these systems are supplied with a third family gas. This also applies to systems in category II_{1a2H} when they are supplied with a second family gas. For systems in category II_{2E+3P} having a gas rate adjuster, it shall be possible to put these devices out of service fully or partially (see 5.2.6) when these systems are supplied with a second family gas.

The adjusters shall be adjustable only with a tool and they shall be capable of being set in the operating position.

5.2.3 Range-rating devices

A range-rating device on a system is optional.

For systems in category II_{1a2H} the gas rate adjuster and the range-rating device may be one and the same. However, if the gas rate adjuster has to be sealed, either completely or partially, when the system is supplied with a second family gas, the gas rate adjuster or its sealed part shall no longer be used by the installer as a range-rating device.

5.2.4 Aeration adjusters

Aeration adjusters are not permitted.

5.2.5 Manual controls

5.2.5.1 Application

Manual valves, push buttons or electrical switches that are essential for normal operation and commissioning of the system shall either be provided with the system or specified in the manufacturer's installation instructions.

5.2.5.2 Manual valves

Manual valves shall be of the 90° turn type.

Manual valves shall be so designed or positioned as to prevent inadvertent operation but shall be easy to operate when required. They shall be so designed that in operation the OPEN and CLOSED positions are readily distinguishable.

When a system isolating valve is provided as an integral part of the system, it shall be capable of operating at a pressure equal to 1,5 times the maximum supply pressure and shall be readily accessible.

Manual valves used solely for OPEN/CLOSED operation shall be provided with positive stops at the OPEN and CLOSED positions.

5.2.6 Regulators

Regulators shall comply with EN 88-1:2007.

Unless a zero regulator is fitted, for a system burning first or second family gases, the gas supply to the burner and any ignition burner shall be under the control of an integral regulator fitted upstream of the automatic shut-off valves unless it is incorporated in a multifunctional control.

For a system burning third family gases, the fitting of a regulator is optional.

The design and accessibility of the regulator shall be such that it can be easily adjusted or put out of service for use with another gas, but precautions shall be taken to make unauthorized interference with the adjustment difficult.

However, for systems in categories I_{2E+}, II_{2E+3+} and II_{2E+3P} the gas regulator shall not be operational in the range of the two normal pressures of the second family pressure couple, i.e. 20 mbar to 25 mbar. For systems in categories II_{2E+3+} and II_{2E+3P}, it shall be possible to put the regulator partially out of service when they are supplied with second family gases, such that the regulator is not operational in the range of the two normal pressures of the second family pressure couple, i.e. 20 mbar to 25 mbar.

5.2.7 Multifunctional controls

Multifunctional controls shall comply with EN 126:2004.

5.2.8 Automatic shut-off valves

Automatic shut-off valves shall comply with EN 161:2007.

The gas supply to the main burner shall be under the control of two automatic shut-off valves connected in the gas line in series; one being of Class A or Class B, the other being of Class A, Class B, Class C or Class J. If a valve of Class J is utilized, a strainer shall be used such that it does not pass a 0,2 mm pin gauge. This strainer shall be fitted upstream of the Class J valve.

The start gas supply shall be under the control of one automatic shut-off valve of either Class A or Class B.

This valve may be the upstream valve in the gas supply to the main burner where it is of Class B and the start gas supply is taken from immediately downstream of this valve. Where the start gas supply is under the control of a single automatic shut-off valve, the heat input at the time of ignition shall not exceed 1 kW or 5 % of the main burner heat input, whichever is the smaller.

The arrangements shown in Figure 1 are given as examples. Any other arrangement giving at least equivalent level of safety is permissible.

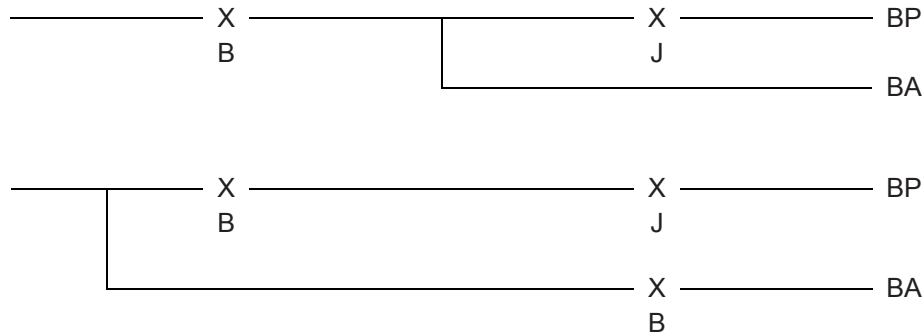

a) Systems with an ignition burner of heat input not exceeding 1 kW or 5 % of the main burner heat input

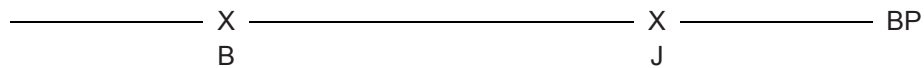

b) Systems with direct ignition of the main burner

Key
 BA Ignition burner
 BP Main burner

Figure 1 — Automatic shut-off valve configuration

5.2.9 Gas strainers

A strainer shall be fitted at the inlet of any burner unit incorporating an automatic shut-off valve(s) to prevent the ingress of foreign matter. The strainer may be integral with the upstream automatic shut-off valve. The maximum strainer hole dimension shall not be greater than 1,5 mm and the mesh shall not permit a 1 mm pin gauge to pass through it.

In gas circuits incorporating more than one automatic shut-off valve, only one strainer need be fitted, provided it gives adequate protection to all valves.

For valves incorporating a shearing action (self-cleaning), and for valves of size ½ (or DN15) and below, the strainer may be omitted.

Where a regulator is fitted upstream of the automatic shut-off valve(s), the strainer may be fitted upstream of the regulator.

5.2.10 Thermostats

Integral mechanical thermostats shall comply with EN 257.

5.2.11 Air proving device

Each burner unit shall be fitted with a suitable device for proving adequate air flow during the pre-purge, ignition and operation of the unit (see 6.6.1 e and 6.6.2).

The sensor shall be located at each burner unit.

The air proving device shall be proved in the no air-flow state prior to start up of the system. Failure to prove the device in the no air-flow state shall prevent start up of the system.

Air-flow failure at any time during the pre-purge, ignition and operation of the burner shall cause non-volatile lock-out, volatile lock-out or safety shut-down such that re-start may only take place following automatic recycling.

The system control shall be designed such that there is at least one check of the pressure switch in the "no air-flow" state every 24 h.

5.2.12 Automatic burner control system

5.2.12.1 General

Each burner unit shall be fitted with an automatic burner control system complying with EN 298:2003.

5.2.12.2 Manually operated devices

The operation of push buttons, switches, etc., incorrectly or out of sequence shall not adversely affect the safety of the automatic burner control system.

Under the test conditions described in 7.2.1, the rapid (on and off) operation of any start switch shall not set up a hazardous condition.

5.2.12.3 Pre-purging

Immediately before any attempt at ignition or the opening of automatic shut-off valves, the system shall be purged.

Under the test conditions described in 7.2.2, the purge period shall be at least 10 s.

5.2.12.4 Flame detector

On each burner unit, the flame detector system shall incorporate a means to prevent the energization of any gas valve and of the ignition device if a flame or flame simulating condition is present during the start-up period.

Upon flame failure in the running condition the flame detector shall cause one of the following:

- a) volatile lock-out; or
- b) non-volatile lock-out; or
- c) one of the following provided that such attempts cannot give rise to a hazardous condition:
 - 1) safety shut-down followed by automatic recycling; or
 - 2) spark restoration.

The time for the flame detector system to de-energize the burner automatic shut-off valves upon flame failure shall not exceed 2 s. This shall be verified under the test conditions described in 7.2.4. Notwithstanding this requirement, where a spark restoration system is used, this time may be extended to allow for the re-ignition attempt but shall not exceed the first safety time.

5.2.12.5 Start-gas flame establishment

The start-gas flame shall be established either at the main burner or at a separate ignition burner.

The first safety time shall be not more than 20 s. The safety time shall be specified by the system manufacturer and verified under the test conditions described in 7.2.3.

The ignition spark (or other means of ignition) shall not be energized before the completion of the pre-purge period and shall be de-energized at or before the end of the first safety time.

The start-gas automatic shut-off valve(s) shall not be energized before the ignition spark (or other means of ignition) is energized.

If the start-gas flame is not detected by the end of the first safety time, volatile or non-volatile lock-out shall result.

The main gas automatic shut-off valves shall not be energized to admit the main gas flow to the burner until after the start-gas flame has been detected.

The upstream automatic shut-off valve in the main gas supply may be opened to permit start-gas flow where the start-gas supply is taken from downstream of the first main gas automatic shut-off valve.

5.2.12.6 Direct main burner flame establishment

The safety time shall be not more than 10 s. The safety time shall be specified by the system manufacturer and verified under the test conditions described in 7.2.3.

The ignition spark (or other means of ignition) shall not be energized before the completion of the pre-purge period and shall be de-energized at or before the end of the safety time.

Where a hot surface ignition device is used, the ignition device shall be so energized that the ignition source is capable of igniting incoming gas before the gas valves are opened.

The main gas valves shall not be energized before the ignition spark (or other means of ignition) is energized. If the main flame is not detected by the end of the main flame ignition period, volatile or non-volatile lock-out shall result.

5.2.12.7 Shut-down

The flame detector device and the air proving device shall affect closure of all automatic shut-off valves in the burner unit concerned. On shut-down the fan shall not be de-energized before the automatic shut-off valves. Post-purging is optional.

5.2.12.8 Facility for remote control

Where the system is capable of being controlled remotely by means of thermostats or a time control, electrical connection of these controls shall be possible without disturbing any internal connection in the system.

5.3 Ignition devices

5.3.1 General

When installed in accordance with manufacturer's instructions, it shall be possible to light the system from an easily accessible position by means of an electrical or other convenient ignition device incorporated in the system.

Ignition burners and ignition devices shall be protected by design and position against diminution or extinction resulting from e.g. draughts, products of combustion, overheating, condensation, corrosion or matter falling from above.

Ignition burners, ignition devices and their mountings shall be so designed that they can only be located rigidly and correctly in relation to every component and burner with which they are designed to operate.

5.3.2 Ignition device for the main burner

Each main burner shall be fitted with an ignition burner or other ignition device for direct ignition.

5.3.3 Ignition burners

If different ignition burners are used when the system is converted from one gas to another, they shall be marked, easy to substitute for one another and easy to fit. The same applies to injectors where only they have to be changed. Injectors shall carry an indelible means of identification and shall only be removable with the aid of a tool.

Ignition burners shall be protected against blockage by gas-borne particulate matter.

5.4 Main burners

The cross-sectional area of the flame ports shall not be adjustable.

The burners shall be so located and arranged that misalignment cannot occur. It shall not be possible to remove the burner assembly without the use of tools.

5.5 Pressure test points

5.5.1 Gas pressure test-point

Each burner unit shall be fitted with at least two pressure test points. One shall be fitted upstream of the first control and safety device and the other downstream of the last gas flow rate control and in a position carefully selected so as to permit measurements to be made.

The test points shall have an external diameter of $(9_{-0,5}^0)$ mm and a useful length of at least 10 mm to enable a tube to be fitted. The minimum diameter of the bore shall not exceed 1 mm.

5.5.2 Air pressure test-point

In addition, a pressure test point shall be fitted for the measurement of suction in each branch tube (see 8.2.2.1n).

5.6 Injectors

Every injector and removable restrictor shall carry an indelible means of identification. It shall be possible to change injectors and restrictors without having to move the tube assembly from its installed position. However, injectors shall only be removable with the aid of a tool.

6 Operational requirements

6.1 Soundness

6.1.1 Soundness of the gas circuit

The gas circuit shall be sound. It is deemed to be sound if, under the conditions described in 7.3.1.1, the leakage of air does not exceed 100 cm³/h irrespective of the number of components, whether mounted in series or parallel on the burner unit.

6.1.2 Soundness of the combustion circuit

The soundness of the combustion circuit upstream of the fan shall be verified in accordance with the requirements in 6.7.

When tested under the conditions of 7.3.1.2, the air leakage rate from any part of the combustion circuit, including its POCED, that is downstream of the fan shall not exceed 0,10 m³/h per kW of the nominal heat input.

6.2 Heat inputs

6.2.1 Nominal heat input

When measured under the conditions described in 7.3.2.2, the heat input obtained at the normal pressure shall be within $\pm 5\%$ of the nominal heat input.

6.2.2 Start gas heat input

When measured under the conditions described in 7.3.2.3 the heat input obtained at normal pressure shall be within $\pm 5\%$ of the start gas heat input declared by the manufacturer.

However, this tolerance is extended to within $\pm 10\%$ where the injector has a diameter of 0,5 mm or less.

6.2.3 Effectiveness of the range-rating device

For burner units fitted with a range-rating device distinct from a gas rate adjuster, it shall be checked under the conditions described in 7.3.2.4 that:

- a) with the range-rating device in the position giving the maximum rate, the nominal heat input is obtained to within $\pm 5\%$; and
- b) with the range-rating device in the position giving the minimum rate, the heat input is within $\pm 5\%$ of the minimum heat input stated by the manufacturer.

6.3 Limiting temperatures

6.3.1 Wall and ceiling temperatures

When the system is tested under the conditions described in 7.3.3.1, the wall and ceiling temperatures shall not exceed the ambient temperature by more than 50 K.

6.3.2 Component temperatures

When the system is tested under the conditions described in 7.3.3.2 the maximum temperature of the system components shall not exceed the maximum temperature specified by the individual component manufacturer.

6.3.3 POCED

When the appliance is tested under the conditions of 7.3.3.3.1, the external temperature of any part of the POCED, which when installed in accordance with the manufacturer's instructions is capable of being less than 25 mm from combustible parts of the fabric of a building, shall not exceed the ambient temperature by more than 50 K.

If, in accordance with the manufacturer's installation instructions, the POCED is required to be enclosed within another duct, a sleeve or insulation when it passes through a combustible wall or ceiling, the external temperatures of this duct, sleeve or insulation shall not exceed the ambient temperature by more than 50 K under the conditions of 7.3.3.3.2.

6.4 Ignition, cross-lighting and flame stability

6.4.1 Ignition and cross-lighting

Under the test conditions described in 7.3.4.1.1, correct and smooth ignition and cross-lighting shall be assured.

When the gas rate of any ignition burner is reduced under the test conditions described in 7.3.4.1.2 to the minimum required to hold open the gas supply to the main burner, correct and smooth ignition of the main burner shall be assured and without undue noise.

Where the gas line is designed such that the gas supply to the ignition burner is taken from between the main burner gas valves, it shall be verified that ignition of the ignition burner under the test conditions described in 7.3.4.1.3 does not give rise to a hazardous situation.

Under the test conditions described in 7.3.4.1.4 ignition of any ignition burner, or the main burner where this is ignited directly, shall be safe and without undue noise when ignition is delayed by up to 50 % longer than the safety time declared by the manufacturer.

6.4.2 Flame stability

Under the test conditions described in 7.3.4.2 the flames shall be stable. A slight tendency to lift at the moment of ignition is acceptable but the flames shall be stable in normal operation.

6.5 Pressure regulator

When tested in accordance with the conditions given in 7.3.5 the rate shall not differ by more than +7,5 % and -10 % for first family gases, and by more than ± 5 % for second and third family gases, from the initial rate obtained under those conditions.

6.6 Combustion

6.6.1 All systems (still air conditions)

When supplied with reference gas under the conditions described in 7.3.6.2:

- a) for Test No. 1, the CO concentration in the dry, air-free products of combustion shall not exceed 0,1 %;

- b) for Test No. 2, the CO concentration in the dry, air-free products of combustion shall not exceed 0,2 %;
- c) for Test No. 3, the CO concentration in the dry, air-free products of combustion shall not exceed 0,2 %.

In addition, when supplied with the sooting limit gas under the same conditions and the system is operated for 3 cycles of 30 min on and 30 min off, there shall be no significant deposit of soot on the inside of the radiant tube and fan.

When supplied with reference gas at normal pressure and the supply voltage is varied under the conditions described in 7.3.6.2:

- d) for Test No. 4, the CO concentration in the dry, air-free products of combustion shall not exceed 0,2 %.

Under these conditions, it shall be verified that the system ignites and continues to operate.

When supplied with reference gas at the normal pressure and the fan voltage is reduced under the conditions described in 7.3.6.2:

- e) for Test No. 5, the CO concentration in the dry, air-free products of combustion shall not exceed 0,2 %.

6.6.2 Supplementary tests under special conditions

When supplied with reference gas under the conditions described in 7.3.6.3, the CO concentration in the dry air-free products of combustion shall not exceed 0,2 %.

In addition, under the conditions described in 7.3.6.3 a) and 7.3.6.3 1 at the point of shut-off, the increase in pressure at the outlet of the installation shall not be less than 0,75 mbar for systems having a wall termination, and 0,5 mbar for systems having a vertical flue.

6.7 Prolonged performance

After the system has been tested under the conditions described in 7.3.7, the following requirements shall be met :

- a) the requirements of 6.6.1 a);
- b) whilst the requirements in 6.7 a) are being verified, there shall be no significant deposition of soot or any appreciable distortion or disturbance of the flames;
- c) there shall be no sign of leakage of combustion products from the combustion chamber, flue connections etc;
- d) there shall be no breakdown or distortion in any part of the system that could affect its safety;
- e) there shall be no significant deterioration in the external surface of the radiant tube for example flaking or excessive oxidation;
- f) there shall be no signs of other corrosion that will adversely affect the life of the system;
- g) following inspection at the end of the test there shall be no evidence of corrosion at the outlet bend and within any POCED.

6.8 Measurement of oxides of Nitrogen, NO_x

The manufacturer shall declare the NO_x class in Table 2 that is applicable to the system.

When measured in accordance with the method of test in 7.4.1, the NO_x concentration(s) in the dry, air-free products of combustion shall be such that the weighted NO_x value, determined as appropriate in accordance with 7.4.2, does not exceed the maximum NO_x concentration of the NO_x class declared by the manufacturer.

Table 2 — NO_x classes

NO _x Class	Maximum NO _x concentration mg/kWh
1	260
2	200
3	150
4	100

7 Test methods

7.1 General

7.1.1 Characteristics of test gases (Reference and limit gases)

Systems are intended for use with gases of different qualities. One of the aims of this standard is to check that the performance of a system is satisfactory for each family or group of gases for which it is designed and for the pressure for which it is designed, if necessary using the adjusting devices.

The test gases, test pressures and system categories given here are in accordance with those specified in EN 437:2003.

The characteristics of the reference and limit gases are given in Tables 4 and 5. The values in Table 4, measured and expressed at 15 °C, are derived from ISO 6976:1995.

7.1.2 Conditions for preparation of the test gases

The composition of gases used for the tests shall be as close as possible to those given in Table 4. For the constitution of these gases, the following rules shall be observed:

- a) the Wobbe index of the gas used shall be within $\pm 2\%$ of the value in Table 4 for the corresponding test gas (this tolerance includes the errors due to measuring instruments);
- b) the constituents used for the preparation of the mixtures shall have at least the purity shown in Table 3.

Table 3 — Test gas purity

Gas	Purity %
Nitrogen (N ₂)	99
Hydrogen (H ₂)	99
Methane (CH ₄)	95 ^{a)}
Propene (C ₃ H ₆)	95 ^{a)}
Propane (C ₃ H ₈)	95 ^{a)}
Butane ³ (C ₄ H ₁₀)	95 ^{a)}
a) With a total concentration of H ₂ , CO and O ₂ below 1 % and a total concentration of N ₂ and CO ₂ below 2 %.	

However, these requirements are not obligatory for each of the components if the final mixture has a composition identical to that of a mixture which would have been made from components satisfying the conditions of Table 3. One can therefore, in order to make up a mixture, start with a gas already containing, in suitable proportions, several constituents of the final mixture.

For gases of the second family:

- c) for the tests carried out with reference gases G 20 or G 25, a gas belonging respectively to either Group H or Group L or Group E, may be used even if its composition does not satisfy the above conditions, provided that after the addition of either propane or nitrogen as appropriate, the final mixture has a Wobbe index within ± 2 % of the value given in Table 4 for the corresponding reference gas;
- d) for preparation of the limit gases another may be used as the base gas instead of methane:
 - 1) for limit gases G 21, G 222 and G 23 a natural gas of Group H may be used;
 - 2) for limit gases G 27 and G 231 a natural gas of Group H or of Group L or of Group E may be used;
 - 3) for the limit gas G 26 a natural gas of Group L may be used.

In all cases the final mixture obtained by adding propane or nitrogen shall have a Wobbe index within ± 2 % of the value given in Table 4 for the corresponding limit gas and the hydrogen content of the final mixture, where appropriate, shall be as given in Table 4.

³ Any mixture of iso/n butane can be used.

Table 4 — Test gas characteristics ^{a)} (gas dry at 15 °C and 1 013,25 mbar)

Gas Family and Group	Test Gases	Designation	Compositi- on volume	W_i	H_i	W_s	H_s	d
			%	MJ/m ³	MJ/m ³	MJ/m ³	MJ/m ³	
Gases of the first family ^{b)}								
Group A	Reference gas incomplete combustion flame lift and	G 110	CH ₄ = 26					
	Sooting limit gases		H ₂ = 50	21,76	13,95	24,75	15,87	0,411
	Light back limit gas	G 112	N ₂ = 24					
			CH ₄ = 17					
			H ₂ = 59	19,48	11,81	22,36	13,56	0,367
			N ₂ = 24					
Gases of the second family								
Group H	Reference gas	G 20	CH ₄ = 100	45,67	34,02	50,72	37,78	0,555
	Incomplete combustion	G 21	CH ₄ = 87					
	Sooting limit gas		C ₃ H ₈ = 13	49,60	41,01	54,76	45,28	0,684
	Light back limit gas	G 222	CH ₄ = 77	42,87	28,53	47,87	31,86	0,443
	Flame lift limit gas	G 23	H ₂ = 23					
CH ₄ = 92,5			41,11	31,46	45,66	34,95	0,586	
			N ₂ = 7,5					
Group L	Reference gas and light back limit gas	G 25	CH ₄ = 86	37,38	29,25	41,52	32,49	0,612
	Incomplete combustion and Sooting limit gas	G 26	N ₂ = 14					
			CH ₄ = 80					
	Flame lift limit gas	G 27	C ₃ H ₈ = 7	40,52	33,36	44,83	36,91	0,678
			N ₂ = 13					
			CH ₄ = 82	35,17	27,89	39,06	30,98	0,629
			N ₂ = 18					
Group E	Reference gas	G 20	CH ₄ = 100	45,67	34,02	50,72	37,78	0,555
	Incomplete combustion	G 21	CH ₄ = 87	49,60	41,01	54,76	45,28	0,684
	Sooting limit gas		C ₃ H ₈ = 13					
	Light back limit gas	G 222	CH ₄ = 77	42,87	28,53	47,87	31,86	0,443
	Flame lift limit gas	G 231	H ₂ = 23					
CH ₄ = 85			36,82	28,91	40,90	32,11	0,617	
			N ₂ = 15					
Gases of the third family ^{c)}								
Third Family and Groups 3B/P and 3B	Reference gas, incomplete combustion and sooting limit gas	G 30	nC ₄ H ₁₀ = 50	80,58	116,09	87,33	125,81	2,075
			iC ₄ H ₁₀ = 50					
	Flame lift limit gas	G 31	C ₃ H ₈ = 100	70,69	88,00	76,84	95,65	1,550
	Light back limit gas	G 32	C ₃ H ₆ = 100	68,14	82,78	72,86	88,52	1,476
Group 3P	Reference gas, Incomplete combustion Sooting and flame lift limit gas	G 31	C ₃ H ₈ = 100	70,69	88,00	76,84	95,65	1,550
	Light back and Sooting limit gas ^{d)}	G 32	C ₃ H ₆ = 100	68,14	82,78	72,86	88,52	1,476

^{a)} For gases used nationally or locally, see Annex B.4.

^{b)} For other groups, see Annex B.4.

^{c)} See also Table 5.

^{d)} See 7.1.2 footnote ³⁾.

Table 5 — Calorific values of the test gases of the third family

Test gas designation	H_i	H_s
	MJ/kg	MJ/kg
G 30	45,65	49,47
G 31	46,34	50,37
G 32	45,77	48,94

7.1.3 Practical application of test gases

7.1.3.1 Choice of test gases

Gases required for the tests described in 7.3.2, 7.3.3, 7.3.4 and 7.3.6 shall be as specified in 7.1.1 and made up in accordance with 7.1.2.

For those tests described in other clauses, it is permissible, in order to facilitate testing, to replace the reference gas by a gas actually distributed, provided that its Wobbe index is within $\pm 5\%$ of that of the reference gas.

When a system can use gases of several groups or families, test gases selected from those listed in Table 2 and in accordance with 7.1.5.1 are used. The selected gases, for each system category, are listed in Table 4.

7.1.3.2 Conditions of supply and adjustment of the burner unit

7.1.3.2.1 Initial adjustment of burner units

Before all the required tests are carried out, the burner unit shall be fitted with the appropriate equipment (injector(s)) corresponding to the gas family or gas group to which the specified test gas belongs (see Table 2). Any gas rate adjuster(s) are set in accordance with the manufacturer's instructions using the appropriate reference gas(es) (see 7.1.5.1) and the corresponding normal pressure(s) given in 7.1.4.

This initial adjustment of the burner unit is subject to the limitations given in 5.1.1.

7.1.3.2.2 Supply pressures

Except where an adjustment of the supply pressure is necessary (as described in 7.1.3.2.3 and 7.1.3.2.4) the normal, minimum and maximum supply pressures to be used for testing purposes shall be in accordance with 7.1.4.

Unless otherwise specified, the initial adjustment of the burner unit shall not be altered.

7.1.3.2.3 Adjustment of heat inputs

For tests requiring adjustment of the burner to the nominal heat input and/or any other heat input specified by the manufacturer, it shall be ensured that the pressure upstream of the injector(s) is such that the heat input obtained is within $\pm 2\%$ of that specified (by altering the pre-set adjuster(s) or the burner unit regulator, if adjustable, or the burner unit supply pressure).

The specified heat input shall be determined in accordance with 7.3.2 and with the burner unit supplied with the appropriate reference gas(es).

7.1.3.2.4 Corrected pressures

Where, in order to obtain the nominal heat input within $\pm 2\%$, it is necessary to use a burner unit inlet pressure, p , different from the normal pressure p_n , then those tests normally carried out at the minimum or maximum test pressures p_{\min} and p_{\max} shall be carried out at the corrected test pressures p'_{\min} and p'_{\max} .

Table 6 — Test gases corresponding to the system categories

Category	Reference gas	Incomplete combustion limit gas	Light back limit gas	Lift limit gas	Sooting limit gas
I _{2H}	G 20	G 21	G 222	G 23	G 21
I _{2L}	G 25	G 26	G 25	G 27	G 26
I _{2E} , I _{2E+}	G 20	G 21	G 222	G 231	G 21
I _{3B/P} , I ₃₊	G 30	G 30	G 32	G 31	G 30
I _{3P}	G 31	G 31	G 32	G 31	G 31, G 32
I _{3B}	G 30	G 30	G 32	G 31	G 30
II _{1a2H}	G 110, G 20	G 21	G 112	G 23	G 21
II _{2H3B/P}					
II _{2H3+}	G 20, G 30	G 21	G 222, G 32	G 23, G 31	G 30
II _{2H3P}	G 20, G 31	G 21	G 222, G 32	G 23, G 31	G 31, G 32
II _{2L3B/P}	G 25, G 30	G 26	G 32	G 27, G 31	G 30
II _{2L3P}	G 25, G 31	G 26	G 32	G 27, G 31	G 31, G 32
II _{2E3B/P}					
II _{2E+3B/P}	G 20, G 30	G 21	G 222, G 32	G 231, G 31	G 30
II _{2E+3+}					
II _{2E+3P}	G 20, G 31	G 21	G 222, G 32	G 231, G 31	G 31, G 32

NOTE Tests with the limit gases are carried out with the injector and adjustment corresponding to the reference gas of the group to which the limit gas used for the test belongs.

The corrected test pressures are calculated using Equation (1).

$$\frac{p'_{\min}}{p_{\min}} = \frac{p'_{\max}}{p_{\max}} = \frac{p}{p_n} \quad (1)$$

where:

- p_n is the normal test pressure;
- p_{\min} is the minimum test pressure;
- p_{\max} is the maximum test pressure;
- p is the burner unit inlet pressure;
- p'_{\min} is the corrected minimum test pressure;
- p'_{\max} is the corrected maximum test pressure.

7.1.4 Test pressures

The test pressures (i.e. the pressures required at the gas inlet connection of the burner unit) are given in Tables 7 and 8.

These pressures and the corresponding injectors are used in accordance with special conditions given in Annex B, for the country in which the system is to be installed (see Annex F and Annex I for national conditions).

In certain circumstances the system manufacturer may specify a normal pressure at the system inlet other than that given in Tables 7 and 8. In these cases the alternative pressure and corresponding injector(s) are used for testing the system and the values of p_{\min} and p_{\max} are determined in accordance with 7.1.3.2.4.

Table 7 — Test pressures where no pressure couple exists^{a)}

System categories having as index	Test gas	p_n	p_{\min}	p_{\max}
		mbar	mbar	mbar
first family: 1A	G 110, G 112	8	6	15
second family: 2H	G 20, G 21, G 222, G 23	20	17	25
second family: 2L	G 25, G 26, G 27	25	20	30
second family: 2E	G 20, G 21, G 222, G 231	20	17	25
third family: 3B/P	G 30, G 31, G 32	29 ^{b)}	25	35
	G 30, G 31, G 32	50	42,5	57,5
third family: 3P	G 31, G 32	37	25	45
	G 31, G 32	50	42,5	57,5
third family: 3B ^{c)}	G 30, G 31, G 32	29	20	35

^{a)} For test pressures corresponding to gases distributed nationally or locally, refer to Table B.4.
^{b)} Systems of this category may be used, without adjustment, at the specified supply pressures of 28 mbar to 30 mbar.
^{c)} The tests with G 31 and G 32 are carried out at the normal pressure only ($p_n = 29$ mbar), these test gases being more severe than any gas of Group 3B. This condition covers the normal variations in the gas supply.

Table 8 — Test pressures where a pressure couple exists

System categories having as index	Test gas	p_n	p_{\min}	p_{\max}
		mbar	mbar	mbar
Second family: 2E+	G 20, G 21, G 222	20	17 ^{b)}	25
	G 231	25 ^{a)}	17	30
Third family: 3+	G 30	29 ^{c)}	20	35
(28-30/37 couple)	G 31, G 32	37	25	45
Third family: 3+	G 30	50	42,5	57,5
(50/67 couple)	G 31, G 32	67	50	80
Third family: 3+	G 30	112	60	140
(112/148 couple)	G 31, G 32	148	100	180

^{a)} This pressure corresponds to the use of low Wobbe index gas but in principle no test is carried out at this pressure.
^{b)} See Annex F.
^{c)} Systems of this category may be used without adjustment at the specified supply pressures of 28 mbar to 30 mbar.

7.1.5 Test procedures

7.1.5.1 Tests requiring the use of reference gas

The tests described in Clauses 7.3.2, 7.3.4 and 7.3.6 shall be carried out with each of the reference gases appropriate to the country in which the system is to be installed, according to the information given in Annex A.

The other tests are carried out with only one of the reference gases of the system category (see 7.1.1) at one of the normal test pressures required in 7.1.4 for the selected reference gas, hereafter referred to as “the reference gas”.

However, the test pressure shall be one of those stated by the manufacturer and the burner unit shall be fitted with the appropriate injector(s).

7.1.5.2 Tests requiring the use of limit gases

These tests shall be carried out with the limit gases appropriate to the system category (see Table 6) and with the injector(s) and adjustment(s) corresponding to the reference gas of the group, or family, to which each limit gas belongs.

7.1.6 General test conditions

7.1.6.1 Test room

The system is installed in a well-ventilated, draught-free room which has an ambient temperature of $(20 \pm 5) ^\circ\text{C}$. A wider temperature range is permitted provided that the test results are not affected.

7.1.6.2 Evacuation of the products of combustion

Systems intended to be fitted with a flue having a wall termination shall be tested with a flue having the same diameter as the flue outlet and of the manufacturer’s maximum equivalent resistance.

Systems intended to be fitted to a vertical flue shall be tested as follows:

- a) systems with a vertical flue outlet shall be tested with a vertical secondary flue as supplied or specified by the appliance manufacturer, having the minimum equivalent resistance specified in the manufacturer’s instructions;
- b) systems with a horizontal flue outlet shall be fitted in accordance with the manufacturer’s instructions; these shall include the maximum length of horizontal run and the method of adaptation to a vertical flue; thereafter, the vertical flue shall be fitted as described in 7.1.6.2a).

Unless otherwise stated the flue shall be uninsulated.

7.1.6.3 Test installation

One burner unit shall be installed on a suitable length of radiant tube, of the material and dimension specified by the manufacturer for the system, and fitted with a damper to enable the suction within the tube to be adjusted within the limits declared by the manufacturer.

The assembly is connected to a fan which, when used on the test installation, has characteristics equivalent to that of a fan specified by the system manufacturer when used on the system.

If necessary, additional tubing with a damper may be introduced into the installation to simulate the effects of other parts of the system on the single burner unit assembly under test.

For the convenience of carrying out tests, the installation may be made at a height above the floor which is other than that specified in the manufacturer's instructions, provided that this does not affect the performance of the system.

7.1.6.4 Influence of thermostats

Precautions shall be taken to prevent thermostats or other controls from operating and affecting the gas rate, unless this is necessary for the test.

7.1.6.5 Electrical supply

The installation is connected to an electrical supply at the nominal voltage, except where otherwise stated.

7.1.6.6 Range rated burner units

For burner units that are designed to be range rated, all tests are carried out at their maximum and minimum nominal heat inputs.

7.2 Construction and design

7.2.1 Manually operated devices (automatic burner control systems)

The system is installed as described in 7.1.6 and supplied with an appropriate reference gas (see Table 4) at the nominal heat input in accordance with 7.1.3.2.3. The start device is manually operated 10 times, once every 5 s.

7.2.2 Pre-purging

Ignite the burner unit in accordance with the manufacturer's instructions, and measure the time between when the full combustion air flow is signalled and the moment when the ignition system is energized.

7.2.3 Safety time

Isolate the gas supply to the burner unit. Attempt to ignite the burner in accordance with the manufacturer's instructions, and measure the time between the signals for valve opening and closure. Compare this time with the manufacturer's specified safety time.

7.2.4 Extinction time

With the burner unit in the running condition, isolate the gas supply to the main burner. Measure the time between the moment when the main burner is extinguished and the signal for valve closure is given.

7.3 Safety of operation

7.3.1 Soundness

7.3.1.1 Soundness of the gas circuit

For burner units using first and/or second family gases only, the tests are carried out with an air inlet pressure of 50 mbar; the inlet valve is however tested with an air pressure of 150 mbar. For burner units using third family gases, all the tests are carried out with an air pressure of 150 mbar. However, if the burner unit is designed to use third family gases at the 112/148 mbar pressure couple, the tests are carried out at a pressure of 220 mbar. Any regulator may be locked in its maximum open position to avoid damage.

Check compliance with 6.1.1 when:

- a) each valve in the main gas supply is tested in turn for soundness in its closed position, all other valves being open;
- b) all gas valves are open and the injectors for any ignition burner and main burner are sealed.

If the gas outlet of the ignition burner cannot be sealed, the test is carried out with the gasway to the ignition burner sealed at a convenient place. In this case an additional test is also carried out, using soap solution, to verify that there is no leakage from the ignition burner when it is operating at its normal working pressure.

For the determination of the leakage rate a volumetric method is used which is of such accuracy that the error in its determination does not exceed 0,01 dm³/h.

These tests are carried out first when the burner unit is delivered and again, on completion of all tests given in this standard, and after any assembly in the gas circuit that has a gas-tight joint whose removal is provided for in the manufacturer's instructions has been removed and replaced 5 times.

7.3.1.2 Soundness of the combustion circuit

The test is carried out using the POCED having the maximum equivalent resistance as specified in the manufacturer's instructions. Seal the inlet and outlet of the duct. Pass air into the duct and note the air flow rate when the pressure within the duct is equivalent to the maximum equivalent resistance.

Check that the leakage rate given in 6.1.2 is not exceeded.

7.3.2 Heat inputs

7.3.2.1 General

For the purposes of this standard all heat inputs are determined from the volumetric flow rate (V_o) or mass flow rate (M_o) which relate to the rate obtained with reference gas under reference test conditions (dry gas, 15 °C, 1 013,25 mbar). The heat input (Q_o) in kilowatt (kW) is based on the net and gross calorific value and is given by Equation (2) or (3).

$$Q_o = 0,278 M_o \times H_i \text{ (or } H_s) \quad (2)$$

or

$$Q_o = 0,278 V_o \times H_i \text{ (or } H_s) \quad (3)$$

where:

M_o is the mass flow rate (kg/h), obtained under reference conditions;

V_o is the volumetric flow rate (m³/h), obtained under reference conditions;

H_i is the net calorific value of the reference gas (MJ/kg) in Equation 2, or MJ/m³ (dry gas, 15 °C, 1 013,25 mbar) in Equation 3;

H_s is the gross calorific value of the reference gas, in MJ/kg) in Equation 2, or in MJ/m³ (dry gas, 15 °C, 1 013,25 mbar) in Equation 3.

The mass and volumetric flow rates correspond to a measurement and to a flow of reference gas, under reference conditions, in other words assuming the gas to be dry, at 15 °C and under a pressure of 1 013,25 mbar. In practice, the values obtained during the tests do not correspond to these reference conditions so they shall then be corrected so as to bring them to the values that would actually have been obtained if these reference conditions had existed at the injector outlet during the test.

If the corrected mass flow rate (M_0) is determined using the mass flow rate (M), Equation (4) is used:

$$M_0 = M \sqrt{\frac{1013,25 + p}{p_a + p} \times \frac{273 + t_g}{288} \times \frac{d_r}{d}} \quad (4)$$

where:

M_0 is the corrected mass flow rate (kg/h), obtained under test conditions;

M is the mass flow rate (kg/h), obtained under test conditions;

p_a is the atmospheric pressure (mbar);

p is the gas supply pressure (mbar);

t_g is the temperature of the gas at the measuring point (°C);

d is the density of dry gas relative to dry air;

d_r is the density of the reference gas relative to dry air.

If the corrected volumetric flow rate (V_0) is determined using the volumetric flow rate (V), Equation (5) is used:

$$V_0 = V \sqrt{\frac{1013,25 + p}{1013,25} \times \frac{p_a + p}{1013,25} \times \frac{288}{273 + t_g} \times \frac{d}{d_r}} \quad (5)$$

where:

V_0 is the corrected volumetric flow rate (m³/h), under reference conditions;

V is the volumetric flow rate (m³/h), obtained under test conditions;

p_a is the atmospheric pressure (mbar);

p is the gas supply pressure (mbar);

t_g is the temperature of the gas at the measuring point (°C);

d is the density of dry gas relative to dry air;

d_r is the density of the reference gas relative to dry air.

The corrected mass flow rate (M_0), under reference conditions is calculated using Equation (6).

$$M_0 = 1,226 V_0 \times d \quad (6)$$

where:

M_0 is the corrected mass flow rate (kg/h), obtained under test conditions;

V_0 is the corrected volumetric flow rate (m³/h), under reference conditions;

d is the density of dry gas relative to dry air.

These formulae are used to calculate, from the mass flow rate, M , or volumetric flow rate, V , measured during the test, the corresponding flow rates M_o or V_o which would have been obtained under the reference conditions.

These formulae are applicable if the test gas used is dry.

If a wet meter is used or if the gas used is saturated, the value d (density of dry gas in relation to dry air) is replaced by the value of the density of the wet gas d_h given by Equation (7).

$$d_h = \frac{d(p_a + p - p_w) + 0,622 p_w}{p_a + p} \quad (7)$$

where:

p_w is the saturation vapour pressure of the test gas expressed in millibar (mbar) at the temperature t_g .

7.3.2.2 Nominal heat input

The tests are carried out at the normal pressure p_n specified by the manufacturer in accordance with 7.1.4.

The burner unit is fitted successively with each of the prescribed injectors and adjusted in accordance with 7.1.3.2.1. The heat input is determined as described in 7.3.2.1 for each reference gas.

The measurements are taken with the installation at thermal equilibrium and with any thermostat put out of action.

The heat input Q_o , obtained, is compared with the nominal heat input Q_n in order to verify compliance with 6.2.1.

7.3.2.3 Start gas heat input

The tests are carried out at the normal pressure p_n specified by the manufacturer in accordance with 7.1.4, using an arrangement which allows operation of the start gas flame on its own.

The burner unit is fitted successively with each of the prescribed injectors and adjusted in accordance with 7.1.3.2.1. The heat input is determined as described in 7.3.2.1 for each reference gas.

The measurements are taken immediately after ignition of the start gas flame.

The heat input obtained is compared with the start gas heat input declared by the manufacturer in order to verify compliance with 6.2.2.

7.3.2.4 Effectiveness of the range-rating device

The tests are carried out as described in 7.3.2.2 for the two extreme positions of the range rating device.

7.3.3 Limiting temperatures

7.3.3.1 Wall and ceiling temperatures

7.3.3.1.1 Apparatus

The apparatus consists of a vertical wooden wall and horizontal ceiling board. The vertical wall is at least 1 200 mm in height and at least 1 200 mm in width. The ceiling board is 1 200 mm in depth and of a similar width to that of the wall. The wall and ceiling are both 25 mm thick wood painted dull black.

For wall mounted systems the ceiling board is arranged such that one edge is against the face of the wall (see Figure 2 a).

This arrangement may not be suitable for other installations (for example ceiling suspension) if a large horizontal clearance is specified by the manufacturer. In this case a 25 mm thick wooden panel may be required to fill the gap between the ceiling board and the wall (see Figure 2 b).

Thermocouples are embedded in each board at 100 mm centres. The thermocouples enter the board on the side remote from the installation, the junctions being fixed 3 mm from the surface of the wood adjacent to the burner unit.

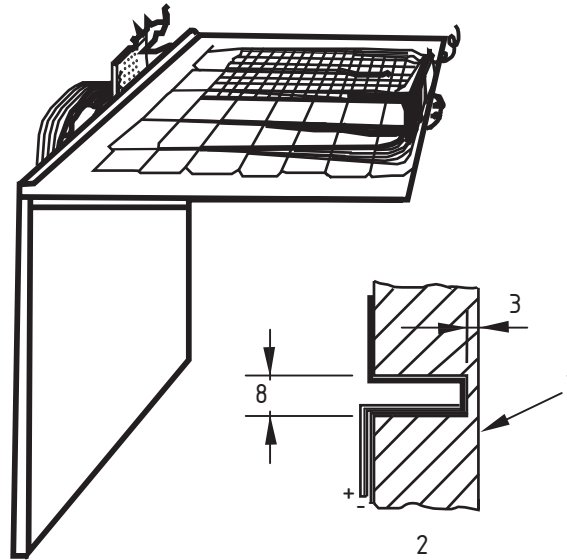

a) Arrangement for wall mounted systems



b) Arrangement for installations with large horizontal clearances

Key

- 1 Face of wall
- 2 Section at thermocouple

Figure 2 — Arrangement for measuring wall and ceiling temperatures

7.3.3.1.2 Procedure

Fit the burner unit and assembly (see 7.1.6.3) to the apparatus in accordance with the manufacturer's instructions regarding clearances (see 8.2).

The test is carried out with the test apparatus positioned adjacent to the part(s) of the installation producing the maximum heating effect.

If the manufacturer specifies a large horizontal clearance the ceiling board shall be positioned centrally over the part(s) of the installation producing the maximum heating effect. Any gap between the ceiling board and the wall shall be filled in as shown in Figure 2 b).

Where the manufacturer's instructions specify alternative installation arrangements (for example wall mounting, ceiling suspension, etc.) repeat the test with the installation fitted to the apparatus accordingly.

The burner unit is supplied with one of the reference gases given in 7.1.1 according to its category and adjusted in accordance with 7.1.3.2.1.

The test is carried out with the burner unit operating at its nominal heat input. All the measurements are taken when thermal equilibrium has been reached. The damper on the burner unit assembly is adjusted to give the minimum suction declared by the manufacturer. It is recommended that for this test the system should be placed in a room where the ambient temperature is approximately 20 °C.

7.3.3.2 Component temperatures

Component temperatures are measured when thermal equilibrium has been reached in the test described in 7.3.3.1 and after the burner unit has been turned off at the end of the test.

The component temperatures are measured by means of attached thermocouples having thermoelectric junctions. Thermocouples shall be used in accordance with EN 60584-1:1995 with the limits of accuracy of the thermoelectric voltage used in accordance with Class 2 of EN 60584-2:1993.

However, if an electrical component is itself likely to cause a rise in temperature (e.g. automatic shut-off valves) the temperature of the component is not measured.

In this case, thermocouples are placed so as to measure the air temperature around the device.

The temperature measurements of the components are deemed to be satisfactory if the requirements of Equation (8) are met.

$$t_{\text{measured}} \leq t_{\text{max}} + t_{\text{ambient}} - 25 \text{ °C} \quad (8)$$

where:

t_{measured} is the maximum temperature (°C) measured in the test;

t_{max} is the maximum temperature (°C), specified by the component manufacturer;

t_{ambient} is the ambient room temperature (°C).

7.3.3.3 POCED

7.3.3.3.1 Test 1

This test is carried out if, when the appliance is installed in accordance with the manufacturer's instructions, any part of the POCED is capable of being less than 25 mm from combustible parts of the fabric of the building.

Install the appliance in accordance with 7.1.6.3 and attach thermocouples junctions to the external surface of those parts of the POCED that are capable of being less than 25 mm from combustible parts of the fabric of the building. Thermocouples shall be used in accordance with EN 60584-1:1995 with the limits of accuracy of the thermoelectric voltage used in accordance with Class 2 of EN 60584-2:1993.

The appliance is supplied with one of the reference gases indicated in 7.1.1 according to its category and adjusted in accordance with 7.1.3.2.1.

The test is carried out with the appliance operating at its nominal heat input. All measurements are taken when thermal equilibrium has been reached. It is recommended that for this test the appliance should be placed in a room where the ambient temperature is approximately 20 °C.

At the end of the test, check that the maximum temperature rise of the POCED does not exceed the limit specified in 6.3.3.

7.3.3.3.2 Test 2

This test is carried out if, in accordance with the manufacturer's installation instructions, the POCED is required to be enclosed within another duct, a sleeve or insulation when it passes through a combustible wall or ceiling.

Install the appliance in accordance with 7.1.6.3. The duct, sleeve or insulation enclosing the POCED shall be fitted in accordance with the manufacturer's instructions. This duct, sleeve or insulation shall be so dimensioned and arranged that it encloses a section of the POCED that is 350 mm in length, as close to the appliance as the manufacturer's instructions allow.

Attach thermocouples junctions to the external surface of the duct, sleeve or insulation and then enclose the duct, sleeve or insulation with a 25 mm thick layer of insulation. Thermocouples shall be used in accordance with EN 60584-1:1995 with the limits of accuracy of the thermoelectric voltage used in accordance with Class 2 of EN 60584-2:1993.

The appliance is supplied with one of the reference gases indicated in 7.1.1 according to its category and adjusted in accordance with 7.1.3.2.1.

The test is carried out with the appliance operating at its nominal heat input. All measurements are taken when thermal equilibrium has been reached. It is recommended that for this test the appliance should be placed in a room where the ambient temperature is approximately 20 °C.

At the end of the test, check that the maximum temperature rise at the external surface of the duct, sleeve or insulation enclosing the POCED does not exceed the limit specified in 6.3.3.

7.3.4 Ignition, cross-lighting and flame stability

7.3.4.1 Ignition and cross-lighting

7.3.4.1.1 Tests with all gases

These tests are carried out both with the installation cold and with the installation at thermal equilibrium under still air conditions.

The installation is made as follows:

- a) for an installation intended to be fitted to a flue having a wall termination shall be connected in turn to a flue of the manufacturer's minimum and maximum equivalent resistance;

- b) for an installation intended to be fitted to a vertical flue having a termination above roof level shall be connected in turn to a vertical flue of the manufacturer's minimum and maximum equivalent resistance.

The burner unit is initially adjusted in accordance with 7.1.3.2.1 and the tests described in 7.3.4.1.1 c) to e) are carried out with the damper on the burner unit assembly adjusted to give alternately the maximum and minimum operating suctions in the assembly declared by the manufacturer.

- c) Test 1

The burner unit is supplied with the appropriate reference and limit gases (see Table 6) at the normal pressure in accordance with 7.1.4.

Under these supply conditions it is checked that ignition of the main burner or the ignition burner occurs correctly and that ignition of the main burner by the ignition burner as well as cross-lighting of the various parts of the burner occurs correctly.

- d) Test 2

For this test the initial burner and ignition burner adjustments are not altered and the burner unit is supplied with reference gas with the pressure at the burner unit inlet reduced to 70 % of the normal pressure or the minimum pressure given in 7.1.4, whichever is the lower.

Under these supply conditions it is checked that ignition of the main burner or the ignition burner occurs correctly and that ignition of the main burner by the ignition burner as well as cross-lighting of the various parts of the burner occurs correctly.

- e) Test 3

Without altering the initial burner or ignition burner adjustment, the appropriate flame lift and light-back limit gases are substituted successively for the reference gas and the pressure is reduced at the burner unit inlet to the minimum pressure given in 7.1.4.

Under these supply conditions it is checked that ignition of the main burner or the ignition burner occurs correctly and that ignition of the main burner by the ignition burner as well as cross-lighting of the various parts of the burner occurs correctly.

7.3.4.1.2 Ignition burner flame reduction

This test is carried out both with the installation cold and with the installation at thermal equilibrium under still air conditions, in accordance with 7.1.6.2.

The burner unit is initially adjusted in accordance with 7.1.3.2.1 and supplied with the appropriate reference gases (see Table 6) at nominal heat input.

The ignition burner gas rate is then reduced to the minimum required to hold open the gas supply to the main burner.

The necessary reduction in the ignition burner gas rate may be achieved either:

- a) by the adjustment of the ignition burner rate adjuster, if this exists; or, if this is not possible,
- b) by means of an adjuster inserted into the ignition burner gas supply for this purpose.

The correct ignition of the main burner by the ignition burner is then checked.

Where an ignition burner has several ports that are likely to become blocked, the test is carried out with all the ignition burner orifices blocked except for the one that is detected by the flame sensor.

7.3.4.1.3 Defective closure of the downstream main burner gas valve

This test is carried out both with the installation cold and with the installation at thermal equilibrium under still air conditions in accordance with 7.1.6.2. The burner unit is initially adjusted in accordance with 7.1.3.2.1 and supplied with the appropriate reference gases (see Table 6) at the nominal heat input with the downstream automatic gas valve in the main gas line kept open. Correct ignition of the system is checked.

7.3.4.1.4 Delayed ignition test

The test is carried out both with the installation cold and with the installation at thermal equilibrium under still air conditions in accordance with 7.1.6.2 at the minimum suction specified by the manufacturer.

The burner unit is initially adjusted in accordance with 7.1.3.2.1 and supplied with the appropriate reference gases (see Table 6) at the nominal heat input.

Ignition of the ignition burner or the main burner, if this is ignited directly, is then checked. The test is repeated, progressively delaying the ignition by up to a maximum of 50 % longer than the safety time declared by the manufacturer.

In order to delay the ignition it will generally be necessary to provide independent control of the main gas or start gas automatic shut-off valves and the operation of the ignition device. A suitable arrangement is to provide a voltage supply, independent of the automatic burner control system, to the relevant gas valve(s) and to the ignition device. For safety reasons the ignition delay should be increased in stages.

The burner unit shall not sustain any damage likely to affect its safe operation.

7.3.4.2 Flame stability

The installation is made as follows:

- a) an installation intended to be fitted to a flue having a wall termination shall be connected in turn to a flue of the manufacturer's minimum and maximum equivalent resistance;
- b) an installation intended to be fitted to a vertical flue having a termination above roof level shall be connected in turn to a vertical flue of the manufacturer's minimum and maximum equivalent resistance.

The burner unit is initially adjusted in accordance with 7.1.3.2.1 and the tests described in 7.3.4.2c) and d) are carried out with the damper on the burner unit assembly adjusted to give alternately the maximum and minimum operating suctions in the assembly declared by the manufacturer.

c) Test 1

Without altering the initial main burner or ignition burner adjustment, the appropriate light-back gases are substituted successively for the reference gas and the pressure is reduced at the burner unit inlet to the minimum pressure given in 7.1.4.

Under these conditions it is checked that the flames are stable.

d) Test 2

Without altering the initial main burner or ignition burner adjustment, the appropriate flame lift and light-back limit gases are substituted successively for the reference gas and the pressure is increased at the burner unit inlet to the maximum given in 7.1.4.

Under these conditions it is checked that the flames are stable.

7.3.5 Pressure regulator

If the burner unit has an adjustable regulator, this is adjusted if necessary to give the nominal heat input with reference gas at the normal pressure given in 7.1.4. Keeping the initial adjustment, the supply pressure is varied between the corresponding minimum and maximum values. This test is carried out for all the reference gases for which the regulator is not put out of action.

7.3.6 Combustion

7.3.6.1 General

The installation is made as follows:

- a) for an installation intended to be fitted to a flue having a wall termination shall be connected in turn to a flue of the manufacturer's minimum and maximum equivalent resistance;
- b) for an installation intended to be fitted to a vertical flue having a termination above roof level shall be connected in turn to a vertical flue of the manufacturer's minimum and maximum equivalent resistance.

The burner unit is initially adjusted to the nominal heat input in accordance with 7.1.3.2.3.

The products of combustion are collected in such a manner as to ensure a representative sample without affecting the performance and the carbon monoxide and carbon dioxide concentrations shall be determined.

The carbon monoxide, CO, concentration is measured by an instrument capable of determining carbon monoxide concentrations between 5×10^{-5} parts by volume and 100×10^{-5} parts by volume.

The carbon monoxide, CO, and carbon dioxide, CO₂, concentrations are measured by a method accurate to within ± 6 %.

For all tests the sample is taken when the installation has reached thermal equilibrium whilst operating under the specified conditions.

The carbon monoxide CO concentration of the dry, air-free products of combustion (neutral combustion) is given by Equation (9).

$$V_{\text{CO,N}} = V_{\text{CO}_2,\text{N}} \times \frac{V_{\text{CO,M}}}{V_{\text{CO}_2,\text{M}}} \quad (9)$$

where:

$V_{\text{CO,N}}$ is the CO concentration of the dry, air-free products of combustion expressed as a percentage;

$V_{\text{CO}_2,\text{N}}$ is the calculated CO₂ content in the dry, air-free products of combustion expressed as a percentage;

$V_{\text{CO,M}}$ and $V_{\text{CO}_2,\text{M}}$ are the carbon monoxide and carbon dioxide concentrations respectively measured in the sample during the combustion test, both expressed as a percentage.

The values of $V_{\text{CO}_2,\text{N}}$ (neutral combustion) are given for the test gases in Table 9.

Table 9 — $V_{\text{CO}_2,\text{N}}$ values (see 7.2.6)

Designation of gas	G 110	G 20	G 21	G 25	G 26	G 30	G 31
$V_{\text{CO}_2,\text{N}}$	7,6	11,7	12,2	11,5	11,8	14,0	13,7

The CO concentration of the dry, air-free products of combustion may also be calculated using Equation (10).

$$V_{\text{CO},\text{N}} = \frac{21}{21 - V_{\text{O}_2,\text{M}}} \times V_{\text{CO},\text{M}} \quad (10)$$

where:

$V_{\text{O}_2,\text{M}}$ and $V_{\text{CO},\text{M}}$ are the oxygen and carbon monoxide concentrations respectively measured in the sample, both expressed as a percentage.

The use of this formula is recommended where it gives greater accuracy than the formula based on the CO₂ concentration.

7.3.6.2 Still air conditions

The tests described in 7.3.6.2 a) to 7.3.6.2 e) are carried out under still air conditions with the damper of the burner unit assembly adjusted to give alternately the maximum and minimum suctions declared by the manufacturer, unless otherwise stated.

a) Test No. 1

Without altering the initial burner adjustment the burner unit is supplied with the appropriate reference gases (see Table 6) according to its category and the pressure at the burner unit inlet increased to the maximum pressure given in 7.1.4.

b) Test No. 2

Without altering the initial burner adjustment, the burner unit is supplied with the appropriate reference gases (see Table 4) according to its category with the pressure at the burner unit inlet reduced to the minimum pressure given in 7.1.4.

c) Test No. 3

Without altering the initial burner adjustment, the appropriate incomplete combustion limit gases are substituted successively for the reference gas and the pressure at the burner unit inlet increased to the maximum pressure given in 7.1.4.

Where necessary, the appropriate sooting limit gases are substituted successively for the incomplete combustion limit gases and the burner unit is operated for 3 cycles of 30 min on and 30 min off. Following the test the installation is inspected for soot deposition within the radiant tube and fan.

d) Test No. 4

Without altering the initial burner adjustment, the burner unit is supplied with the appropriate reference gases (see Table 6) according to its category and operated at the nominal heat input.

The test is carried out with the installation supplied with electricity at a voltage of 85 % of the minimum and then at a voltage of 110 % of the maximum of the voltage range stated by the manufacturer.

e) Test No. 5

Without altering the initial burner adjustment, the burner unit is supplied with the appropriate reference gases (see Table 6) according to its category and operated at the nominal heat input.

For the purposes of this test the fan only shall be supplied with electricity by means of a suitable device which permits variation in voltage.

With the installation operating at thermal equilibrium, gradually reduce the voltage supply to the fan until the gas is shut-off by the air proving device. Sample the products of combustion until the moment when the gas supply is shut off.

For the purposes of this test, the burner assembly damper is adjusted to give only the minimum suction declared by the manufacturer.

7.3.6.3 Supplementary tests under special conditions

Without altering the initial adjustment, the burner unit is supplied with the appropriate reference gases (see Table 6) according to its category and operated at the nominal heat input.

A system intended to be used with a flue having a wall termination shall be tested under the following conditions:

- a) with the installation connected to a flue of the manufacturer's maximum equivalent resistance, the flue outlet is progressively restricted until the gas is shut off by the air proving device.

The test is carried out with the damper in the burner unit assembly adjusted to give the minimum suction (i.e. equivalent to minimum flow) declared by the manufacturer.

- b) with a suction applied to the outlet of the flue so as to reduce the pressure at the outlet of the installation to 0,5 mbar below that produced by a flue of the manufacturer's minimum equivalent resistance.

The test is carried out with the damper in the burner unit assembly adjusted to give the maximum suction (i.e. equivalent to maximum flow) declared by the manufacturer.

A system intended to be used with a vertical flue having a termination above roof level shall be tested under the following conditions:

- c) with the installation connected to a flue of the manufacturer's maximum equivalent resistance, the flue outlet is progressively restricted until the gas is shut off by the air proving device.

The test is carried out with the damper in the burner unit assembly adjusted to give the minimum suction (i.e. equivalent to minimum flow) declared by the manufacturer.

With a suction applied to the outlet of the flue so as to reduce the pressure at the outlet of the installation to 0,5 mbar below that produced by a flue of the manufacturer's minimum equivalent resistance.

The test is carried out with the damper in the burner unit assembly adjusted to give the maximum suction (i.e. equivalent to maximum flow) declared by the manufacturer.

7.3.7 Prolonged performance

The test is carried out after all other tests given in 7.3 have been carried out.

The installation is made in accordance with 7.1.6.2 and initially adjusted as described in 7.1.3.2.1. The damper in the burner unit assembly is adjusted to give the minimum suction (i.e. to give the minimum flow) declared by the manufacturer.

The test is carried out with the burner unit supplied with one of the appropriate reference gases (see Table 6) according to its category. The pressure at the burner unit inlet is then increased to the maximum pressure given in 7.1.4.

The installation is operated continuously for 20 h under these adjustment conditions and then compliance with 6.7 is verified.

7.4 Other pollutants

7.4.1 General

The system shall be installed as specified in 7.1.6 and connected to a flue as described in 7.1.6.2.

For systems intended to use second family gases, the tests are carried out using test gas G 20, if the system category is such that this test gas is used as a reference gas. If G 20 is not used as a reference gas, the tests are carried out using G 25 exclusively.

For systems intended to use all gases of the third family, the tests are carried out with reference gas G 30 and the maximum NO_x concentration (see Table 2) is multiplied by a factor of 1,30.

For systems intended to use propane only, the tests are carried out with reference gas G 31 and the maximum NO_x concentration is multiplied by a factor of 1,20.

The system is adjusted to its nominal heat input.

The NO_x measurements are carried out when the system is at thermal equilibrium, conforming to details given in CR 1404:1994.

No wet meters are used.

The reference conditions for the combustion air are:

- a) temperature: 20 °C;
- b) relative humidity H_o : 10 g(H₂O)/kg(air).

If the test conditions are different to these reference conditions, it is necessary to correct the NO_x values using Equation (11).

$$NO_{x,reference} = NO_{x,m} + \frac{0,02 NO_{x,m} - 0,34}{1 - 0,02 (h_m - 10)} (h_m - 10) + 0,85(20 - T_m) \quad (11)$$

where:

NO_{x,reference} is the value of NO_x corrected to the reference conditions (mg/kWh);

NO_{x,m} is the NO_x measured at h_m and T_m (mg/kWh) in the range 50 mg/kWh to 300 mg/kWh;

NOTE Where NO_x is measured in ppm, convert it to mg/kWh in accordance with Annex H.

h_m is the humidity during the measurement of NO_{x,m} (g/kg) in the range 5 g/kg to 15 g/kg;

T_m is the ambient temperature (°C) during the measurement of NO_{x,m} in the range 15 °C to 25 °C.

The measured NO_x values are weighted in accordance with 7.4.2.

It is checked that the weighted NO_x values comply with the values of Table 10, depending on the NO_x class chosen.

7.4.2 Weighting

7.4.2.1 General

The weighting of the NO_x measured values shall be calculated as described in 7.4.2.2 to 7.4.2.5, on the basis of the values in Table 10.

Table 10 — Weighting factors

Partial heat input $Q_{pi,\%}$ as % of Q_n	Weighting factor F_{pi}
70	0,15
60	0,25
40	0,30
20	0,30

For range rated systems Q_n is replaced by Q_a , the arithmetic mean of the maximum and the minimum heat input of the range, as stated by the manufacturer.

7.4.2.2 On/off systems

The NO_x concentration is measured (and possibly corrected as specified in 7.4.1) at the nominal heat input, Q_n .

7.4.2.3 Systems with several rates

The NO_x concentration is measured (and possibly corrected as specified in 7.4.1) at the partial heat input corresponding to each of the rates and weighted in accordance with Table 10.

If necessary, the weighting factor specified in Table 10 is recalculated for each rate as specified below.

If the heat inputs of two rates are between the partial heat inputs specified in Table 10, it is necessary to apportion the weighting factor between the heat inputs of the higher rate using Equation (12):

$$F_{p,high\ rate} = F_{pi} \times \frac{Q_{pi,\%} - Q_{low\ rate,\%}}{Q_{high\ rate,\%} - Q_{low\ rate,\%}} \times \frac{Q_{high\ rate,\%}}{Q_{pi,\%}} \quad (12)$$

where:

$F_{p,high\ rate}$ is the apportioned weighting factor, high rate;

F_{pi} is the weighting factor corresponding to the partial heat input $Q_{pi,\%}$;

$Q_{pi,\%}$ is the partial heat input for weighting, expressed in percent of Q_n ;

$Q_{low\ rate,\%}$ is the heat input rate less than $Q_{pi,\%}$;

$Q_{\text{high rate, \%}}$ is the heat input rate greater than $Q_{\text{pi, \%}}$;

and the lower rate using Equation (13).

$$F_{\text{p, low rate}} = F_{\text{pi}} - F_{\text{p, high rate}} \quad (13)$$

where :

F_{pi} is the weighting factor corresponding to the partial heat input $Q_{\text{pi, \%}}$;

$F_{\text{p, low rate}}$ is the apportioned weighting factor, low rate;

$F_{\text{p, high rate}}$ is the apportioned weighting factor, high rate.

If the heat inputs of two rates cover more than one partial heat input specified in Table 10, then it is necessary to apportion each weighting factor between the heat inputs of the higher and lower rate as indicated above.

The weighted NO_x value ($\text{NO}_{x, \text{pond}}$) is then equal to the sum of the products of the measured NO_x values at the different rates, multiplied by their weighting factor as given by Equation (14).

$$\text{NO}_{x, \text{pond}} = \sum (\text{NO}_{x, \text{mes high}} \times F_{\text{p, high rate}}) \quad (14)$$

where:

$\text{NO}_{x, \text{pond}}$ is the weighted NO_x value (mg/kWh);

$\text{NO}_{x, \text{mes high}}$ is the measured (and possibly corrected) NO_x value (mg/kWh), high rate;

$F_{\text{p, high rate}}$ is the apportioned weighting factor, high rate.

(See Annex G and Annex H.)

7.4.2.4 Modulating systems in which the minimum modulating heat input is no greater than 0,20 Q_n

The NO_x concentration is measured (and possibly corrected as specified in 7.4.1) at the partial heat inputs specified in Table 10.

The weighted NO_x value ($\text{NO}_{x, \text{pond}}$) is determined using Equation (15).

$$\text{NO}_{x, \text{pond}} = 0,15 \times \text{NO}_{x, \text{mes}(70)} + 0,25 \times \text{NO}_{x, \text{mes}(60)} + 0,3 \times \text{NO}_{x, \text{mes}(40)} + 0,3 \times \text{NO}_{x, \text{mes}(20)} \quad (15)$$

where:

$\text{NO}_{x, \text{pond}}$ is the weighted NO_x value (mg/kWh);

$\text{NO}_{x, \text{mes}(70)}$ the measured (and possibly corrected) NO_x value (mg/kWh), 70 % heat input;

$NO_{x,mes(60)}$ the measured (and possibly corrected) NO_x value (mg/kWh), 60 % heat input;

$NO_{x,mes(40)}$ the measured (and possibly corrected) NO_x value (mg/kWh), 40 % heat input;

$NO_{x,mes(20)}$ the measured (and possibly corrected) NO_x value (mg/kWh), 20 % heat input.

7.4.2.5 Modulating systems in which the minimum modulating heat input is greater than 0,20 Q_n

The NO_x concentration is measured (and possibly corrected as specified in 7.4.1) at the minimum modulating rate and at the partial heat inputs $Q_{pi,\%}$, specified in Table 10, which are greater than the minimum modulation rate.

The weighting factors for the partial heat inputs in Table 10, which are no greater than the minimum modulation rate are added and multiplied by $NO_{x,mes,Qmin}$.

The weighted NO_x value, $NO_{x,pond}$, is determined using Equation (16).

$$NO_{x,pond} = NO_{x,mes,Qmin} \sum F_{pi} (Q_{pi\%} \leq Q_{min\%}) + \sum (NO_{x,mes} \times F_{pi} [Q_{pi\%} > Q_{min\%}]) \quad (16)$$

where:

$NO_{x,pond}$ is the weighted NO_x value (mg/kWh);

$NO_{x,mes}$ is the measured (and possibly corrected) NO_x value (mg/kWh) at the partial heat input(s), $Q_{pi,\%}$, greater than the minimum modulating rate, $Q_{min\%}$;

$NO_{x,mes,Qmin}$ is the measured (and possibly corrected) NO_x value (mg/kWh) at the minimum heat input (modulating appliances) :

$Q_{min\%}$ is the minimum modulating rate, expressed as a percentage of Q_n ;

F_{pi} is the weighting factor corresponding to the partial heat input $Q_{pi,\%}$.

8 Marking and instructions

8.1 Marking of the system and the packaging

8.1.1 Designation

Systems are designated by their:

- category;
- nominal input, or range of adjustable input;
- flue type.

8.1.2 Data plate

Each burner unit shall carry one or more data plates and/or labels that are firmly and durably attached to the unit such that the information given is visible to, and can be read by, the installer. The data plate(s) and/or label(s) shall give at least the following information in indelible characters:

- a) the manufacturer's⁴ name or identification symbol;

NOTE The PIN-number is acceptable as identification symbol of the manufacturer.

- b) the nominal heat input and, where necessary, the range of input for the system with an adjustable input, expressed in kW, stating whether it is based on net or gross calorific value;
- c) the trade name of the system;
- d) the serial number;
- e) the commercial identification symbol of the system;
- f) the type of gas in relation to the pressure and/or the pressure couple, for which each burner unit has been adjusted; any pressure indication identified in relation to the corresponding category index. If an intervention is necessary on the system in order to change from one pressure to the other within a pressure couple of the third family, only the pressure corresponding to the current adjustment of the system shall be indicated;
- g) the direct country or countries of destination of the system;
- h) the system category or categories. If more than one system category is specified, each of these categories shall be identified in relation to the appropriate direct country or countries of destination;
- i) the setting pressure for regulated systems;
- j) the nature and voltage of the current used and the maximum electrical power used, in volts, amperes, frequency and kilowatts for all intended electrical supply conditions;
- k) the NO_x class of the system.

No other information shall be included on the system burner unit if this could lead to confusion with regard to the current state of adjustment of system, the corresponding system category (or categories) and the direct country (or countries) of destination.

For a system with an adjustable nominal input, there shall be room for the installer to durably mark the input value for which it has been adjusted on commissioning.

The indelibility of the marking shall be checked by a test carried out in accordance with 7.14 of EN 60335-1:2002.

8.1.3 Other marking

The system burner unit shall be marked with the following text:

“This system must be installed in accordance with the rules in force, and used only in a sufficiently ventilated space. Consult instructions before installation and use of this system.”

The manufacturer shall also provide a suitable plate or durable label for attachment on, or adjacent to, any low level⁵⁾ user control. This plate or label shall be indelibly marked with the instructions for the safe operation of the system including its lighting and shut-down procedures.

⁴ “Manufacturer” means the organization or company which assumes responsibility for the product.

⁵⁾ Low level means accessible to the user standing on the ground.

Permanent warning notices shall be provided in a readily visible position on the burner unit requiring the system to be switched off and the gas isolated before carrying out any service operation.

8.1.4 Marking on the packaging containing the burner

The packaging shall carry at least the following information:

- a) the type of gas in relation to the pressure and/or pressure couple for which the burner unit has been adjusted; any pressure indication identified in relation to the corresponding category index. If an intervention is necessary on the burner unit in order to change from one pressure to the other within a pressure couple of the third family, only the pressure corresponding to the current adjustment of the burner unit shall be indicated;
- b) the direct country or countries of destination of the system;
- c) the system category or categories. If more than one system category is specified, each of these categories shall be identified in relation to the appropriate direct country or countries of destination.

In addition, it shall be marked with the following text:

“This system must be installed in accordance with the rules in force, and used only in a sufficiently ventilated space. Consult instructions before installation and use of this system.”

No other information shall be included on the packaging if this could lead to confusion with regard to the current state of adjustment of the system, the corresponding system category (or categories) and the direct country (or countries) of destination.

8.1.5 Utilization of symbols on the system and packaging

8.1.5.1 Electrical supply

The marking concerning electrical values shall be in conformity with EN 60335-1:2002.

8.1.5.2 Type of gas

In order to represent all of the category indices corresponding to the adjustment of a system, the symbol of the reference gas shall be used which is common to all of these indices, in accordance with Table 8.

Table 11 — Gas type symbol

Gas type symbol		Corresponding category index
First family ^{a)}	G 110	1A
	G 120	1B
	G 130	1C
	G 150	1E
Second family	G 20	2H, 2E, 2E+, 2Esi ^{b)} , 2Er ^{b)} , 2ELL ^{b)}
	G 25	2L, 2ESi ^{c)} , 2Er ^{c)} , 2ELL ^{c)}
Third family	G 30	3B/P, 3+ ^{d)} , 3B
	G 31	3+ ^{e)} , 3P
<p>^{a)} If, in its current state of adjustment, the system can use gases from different groups, all the reference gases corresponding to these groups shall be indicated.</p> <p>^{b)} When the system is adjusted for G 20.</p> <p>^{c)} When the system is adjusted for G 25.</p> <p>^{d)} Only applies to systems which do not need any adjustment between G 30 and G 31, or to systems which need an adjustment and which are adjusted for G 30.</p> <p>^{e)} Only applies to systems which need an adjustment between G 30 and G 31, and which are adjusted for G 31.</p> <p>^{f)} For the systems which need an adjustment between G 30 and G 31, the label concerning the adjustment to the other gas and the other pressure of the pressure couple shall be supplied with the technical instructions.</p>		

In order to satisfy the needs expressed by CEN Members it is permitted that their countries declared means of identification may be included in addition to the symbol. These additional means are given in Annex E.

8.1.5.3 Gas supply pressure

The gas supply pressure can be expressed uniquely by the numerical value using the unit (mbar). Nevertheless, if it is necessary to explain this value, the symbol “*p*” shall be used.

8.1.5.4 Country of destination

In accordance with EN ISO 3166-1:2006, the names of countries shall be represented by the codes shown in Table 12:

Table 12 – Country codes

AT	Austria	IE	Ireland
BE	Belgium	IS	Iceland
BG	Bulgaria	IT	Italy
CH	Switzerland	LT	Lithuania
CY	Cyprus	LU	Luxembourg
CZ	Czech Republic	LV	Latvia
DE	Germany	MT	Malta
DK	Denmark	NL	Netherlands
EE	Estonia	NO	Norway
ES	Spain	PL	Poland
FI	Finland	PT	Portugal
FR	France	RO	Romania
GB	United Kingdom	SE	Sweden
GR	Greece	SI	Slovenia
HU	Hungary	SK	Slovakia

8.1.5.5 Category

The category can be expressed uniquely by its designation in accordance with EN 437:2003. Nevertheless, if it is necessary to explain it, the term “category” shall be symbolized by “cat”.

8.1.5.6 Other information

The symbols given below are not obligatory, but are recommended under the title “preferential”, and to the exclusion of any other symbol, to avoid the use of many and different markings.

8.1.5.6.1 Nominal heat input of a burner Q_n

8.1.5.6.2 Nominal heat input of all system burners ΣQ_n

8.2 Instructions

8.2.1 General

They shall be written in the official language(s) of the country or countries of destination stated on the system and shall be valid for that or those countries.

If the instructions are written in an official language that is used by more than one country, the country or countries for which they are valid shall be identified by the codes given in 8.1.5.4.

Instructions for countries other than those stated on the system may be supplied with the system, on condition that each set of instructions has the following initial statement:

“These instructions are only valid if the following country code is on the system. If this code is not present on the system, it is necessary to refer to the technical instructions which will provide the necessary information concerning the modification of the system to the conditions of use for the country.”

8.2.2 Technical instructions

8.2.2.1 Technical instructions for installation and adjustment

In addition to the information given in 8.1.2, the technical instructions may include information indicating, where appropriate, that the system has been certified for use in countries other than those stated on the system⁶ If such information is given, the instructions shall include a warning that modification of the system and its method of installation are essential in order to use the system safely and correctly in any of these additional countries. This warning shall be repeated in the official language(s) of each of these countries. Furthermore, the instructions shall indicate how to obtain the information, instructions and parts necessary for safe and correct use in the countries concerned.

The technical instructions for installation and adjustment, intended for the installer, shall be supplied with the system. The instructions shall be clear and simple and the terms shall be those in common usage. Wherever necessary, diagrams and/or photographs shall augment the text.

The technical instructions shall include the following statement:

“Before installation, check that the local distribution conditions, nature of gas and pressure, and adjustment of the system are compatible.”

The technical instructions shall refer to:

- a) the method of connection of the flue and the installation regulations in the country where the system is to be installed (if such regulations exist); also the flue dimensions shall be given for the purposes of installation in those countries where there are no appropriate regulations;
- b) the construction of the flue;
- c) the method of assembly and, in particular, the method of connecting the tube section(s), together with any sealing material to be used where these are necessary to ensure soundness;
- d) the use and siting of thermostats and other controls;
- e) the siting of the system, including the minimum clearances around the system and its POCED, any insulation or sleeve required, and the minimum fixing height above the floor which shall be in accordance with National Installation Regulations;
- f) the method of installing the POCED, including any necessary supporting elements, the method of attachment to the building and a statement confirming that the POCED is capable of withstanding its own weight;

⁶ Indirect country of destination.

- g) fluing, including its maximum and minimum equivalent resistance of the POCED after any fan⁷;
- h) the heat loss via the flue, if required (see Annex K);
- i) the combustion and ventilation air requirements;
- j) the gas and electricity supply and connections;
- k) the procedure to be followed for commissioning the system;
- l) the means by which the “no air-flow” state of the pressure switch can be checked at least once every 24 h;
- m) the maximum number of burner and burner branches in the system;
- n) a minimum specification for the radiant tubes to be used in the system;
- o) a specification for the fan in the system;
- p) details of the means of determining the suction in each branch tube, and where necessary, the installation of a pressure test point(s) for this purpose;
- q) a wiring diagram for the system;
- r) the method of disposing of any condensate built up during the operation of the system;
- s) the range of operating suctions over which each burner unit can operate.

In particular, the instructions shall give details of the adjustment of any dampers in the branch tubes of the system. This procedure shall include the means of checking that the burner units operate within the manufacturer's specified range of operating suctions.

The instructions shall include a statement that the system shall not be altered without consulting the system manufacturer.

The system manufacturer shall supply all necessary information for planning the system in order to guarantee safe operation of the system in all normal configurations of operation.

The instructions shall specify that, following installation, the installer must check that, under all possible configurations of normal operation, the system functions in accordance with the manufacturer's instructions.

In addition, the installation instructions shall include a complete wiring diagram for the burner unit and a technical data table. The technical data table shall include:

- t) the burner unit heat input;
- u) the rating of any ignition burner;
- v) the nature of the gas used (e.g. Wobbe index);

⁷ The minimum and maximum equivalent resistance corresponds to the POCED supplied or specified by the manufacture with the minimum and maximum resistance to flow. Due account shall be taken of the resistance to flow of any terminal supplied or specified by the manufacturer.

- w) the burner pressure, and for a burner unit with an adjustable regulator, the setting pressure as measured upstream of the burner but downstream of any adjuster, in relation to the nature of the gas used;
- x) injector sizes;
- y) number of injectors;
- z) gas connection size;
- aa) flue size;
- bb) physical dimensions;
- cc) weight;
- dd) electric motor details;
- ee) any other technical data as may be required by the installer and commissioning engineer;
- ff) the maximum and minimum suctions over which the burner units are intended to operate.

The installation instructions shall state that an isolation valve, or valves, has to be fitted immediately adjacent to each burner unit which, when closed, allow(s) the complete burner and control assembly to be disconnected for maintenance or repair.

8.2.2.2 Conversion instructions

The manufacturer's conversion instructions are to be sent, on request, to all qualified installers. They may form part of the installation instructions.

The components required for conversion to another type of gas or another pressure, shall be supplied with clear and adequate instructions regarding the change of components, and the cleaning, adjustment and checking of the system.

In addition, a self-adhesive label shall be supplied to be placed on the burner unit, indicating the nature and pressure of the gas for which it has been adjusted and also, where appropriate, the heat input set during commissioning.

8.2.3 Instructions for use and maintenance

Instructions for use and maintenance shall be supplied with every system.

These instructions, which are intended for the user, shall provide all the necessary information for the safe and sensible use of the system.

The instructions shall be clear and simple and the terms shall be acceptable in common usage. Wherever necessary, diagrams and/or photographs shall augment the text. The instructions shall contain notes on the care and safe operation of the system including its lighting and shut-down procedures.

They shall also stress that a qualified installer is required to install the system and, if the need arises, to convert it for use with other gases. They shall state the recommended frequency of periodic servicing and draw particular attention to the need for periodic sweeping of the flue according to the regulations in the country where the system is to be installed. Finally, they shall deal briefly with the installation regulations (connection, ventilation) in the country where the system is to be installed.

8.3 Presentation

All the information specified in 8.1.1, 8.1.2, 8.1.3, 8.1.4, 8.1.5, 8.2.1, 8.2.2 and 8.2.3 shall be given in the language(s) of the country in which the system is to be installed. Calorific values shall be net or gross according to the custom of that country.

9 Evaluation of conformity of POCEDs and their associated terminals

9.1 General

The compliance of a POCED and its associated terminal with the requirements of this standard shall be demonstrated by:

- a) initial type testing;
- b) factory production control by the manufacturer, including product assessment.

NOTE The requirements are given in the relevant tables ZB.1 or ZB.2.

9.2 Type testing

9.2.1 Initial type testing

Initial type testing shall be performed to show conformity the requirements of this standard. Tests previously performed in accordance with the provisions of this standard (same product, same characteristic(s), test method, sampling procedure, system of attestation of conformity, etc.) may be taken into account. In addition, initial type testing shall be performed at the beginning of the production of a new POCED and/or its associated terminal, or at the beginning of a new method of production (where this may affect the stated properties).

NOTE The requirements are given in the relevant tables ZB.1 or ZB.2.

Where characteristics are determined on the basis of conformity with other product standards (for metals including coatings, seals and sealants), these characteristics do not need to be reassessed provided that the designer ensures the validity of the results. Products CE marked in accordance with appropriate harmonised European specifications may be presumed to have the performances stated of them, although this does not replace the responsibility of the manufacturer to ensure that the POCED and any associated terminal as a whole is correctly designed and its component products have the necessary performance values.

9.2.2 Further type testing

Whenever a change occurs in the POCED, any associated terminal, the raw material or supplier of the components, or the production process, which would change the tolerances or one or more of the characteristics that are assessed by the requirements of this standard, the type tests shall be repeated for the appropriate characteristic(s).

9.2.3 Sampling for type testing

Unless otherwise stated in the particular test method given in Clause 7 of this standard, type testing is carried out utilising a POCED, and any associated terminal, having the minimum and maximum equivalent resistance.

The results of all type tests shall be recorded and held by the manufacturer, until superseded.

9.3 Factory production control (FPC)

9.3.1 General

NOTE 1 A FPC system conforming with the following requirements of the relevant part(s) of EN ISO 9001:2000, and made specific to the requirements of this standard, is considered to satisfy the above requirements.

The manufacturer shall establish, document and maintain a FPC system to ensure that the manufactured products conform to the stated performance characteristics. The FPC system shall consist of procedures, regular inspections and tests and/or assessments and the use of the results to e.g. control raw and other incoming materials or components, equipment, the production process and the product.

The manufacturer is responsible for organising the effective implementation of the factory production control system. Tasks and responsibilities in the production control organisation should be documented and this documentation should be kept up-to-date. In each factory the manufacturer may delegate the action to a person having the necessary authority to:

- a) identify procedures to demonstrate conformity of the product at appropriate stages;
- b) identify and record any instance of non-conformity;
- c) identify procedures to correct instances of non conformity.

The manufacturer should draw up and keep up-to-date documents defining the factory production control which he applies. The manufacturer's documentation and procedures should be appropriate to the product and manufacturing process. All FPC systems should achieve an appropriate level of confidence in the conformity of the product. This involves:

- d) the preparation of documented procedures and instructions relating to factory production control operations, in accordance with the requirements of the reference technical specification;
- e) the effective implementation of these procedures and instructions;
- f) the recording of these operations and their results;
- g) the use of these results to correct any deviations, repair the effects of such deviations, treat any resulting instances of non-conformity and, if necessary, revise the FPC to rectify the cause of non-conformity.

The production control operations shall include some or all of the following operations:

- h) the specification and verification of raw materials and constituents;
- i) the controls and tests to be carried out during manufacture according to a frequency laid down;
- j) the verifications and tests to be carried out on finished products according to a frequency which may be laid down in the technical specifications and adapted to the product and its conditions of manufacture.

NOTE 2 Depending on the specific case, it may be necessary to carry out:

- 1) the operations referred to under i) and j),
- 2) only the operations under i), or

- 3) only those under j).

The operations under i) centre as much on the intermediate states of the product as on manufacturing machines and their adjustment, and equipment, etc. These controls and tests and their frequency are chosen based on product type and composition, the manufacturing process and its complexity, the sensitivity of product features to variations in manufacturing parameters, etc.

The manufacturer shall have or have available the installations, equipment and personnel which enable him to carry out the necessary verifications and tests. He may, as may his agent, meet this requirement by concluding a sub-contracting agreement with one or more organisations or persons having the necessary skills and equipment.

The manufacturer has responsibility to calibrate or verify and maintain the control, measuring or test equipment in good operating condition, whether or not it belongs to him, with a view to demonstrating conformity of the product with its technical specification. The equipment shall be used in conformity with the specification or the test reference system to which the specification refers.

If necessary, monitoring is carried out of the conformity of intermediate states of the product and at the main stages of its production.

This monitoring of conformity focuses where necessary on the product throughout the process of manufacture, so that only products having passed the scheduled intermediate controls and tests are dispatched.

The results of inspections, tests or assessments requiring action shall be recorded, as any action taken. The action to be taken when control values or criteria are not met shall be recorded.

9.3.2 Equipment

All weighing, measuring and testing equipment shall be calibrated and regularly inspected according to documented procedures, frequencies and criteria.

9.3.3 Raw materials and components

The specifications of all incoming raw materials and components shall be documented, as the inspection scheme for ensuring their conformity.

9.3.4 Product testing and evaluation

The manufacturer shall establish procedures to ensure that the stated values of the characteristics are maintained. An example of a sampling plan for FPC is given in Annex J.

9.3.5 Non-conforming products

The manufacturer shall establish procedures for dealing with non-conforming products.

Annex A **(informative)**

National situations

NOTE This Annex does not apply to POCEDs (chimneys).

A.1 General

In each country in which this standard applies, appliances can only be installed if the category corresponds to the national situations of that country. Categories corresponding to the national situations of the EU countries are listed in Tables A.1 and A.2.

In order to permit, both at the time of testing the system and at the time of its sale, the correct choice to be made from all the situations covered, the various national situations are summarized in A.2, A.3, A.4, A.5, A.6 and A.7.

A.2 Categories listed in the body of the standard and marketed in different countries

Tables A.1 and A.2 give the national situations concerning the marketing in the various countries of the system categories listed in the body of the standard.

The information given in the table indicates only that these categories may be sold throughout the whole of the country concerned and A.3 should be consulted for confirmation.

In all cases of doubt the local gas supplier should be consulted in order to identify the precise category applicable.

Table A.1 — Category I (single) categories marketed

Country	I _{2H}	I _{2L}	I _{2E}	I _{2E+}	I _{2N}	I _{2R}	I _{3B/P}	I ₃₊	I _{3P}	I _{3B}	I _{3R}
AT	X						X				
BE				X				X	X		
BG											
CH	X						X	X	X		
CY ^a											
CZ	X						X		X		
DE			X				X		X		
DK	X						X				
EE ^a											
ES	X							X	X		
FI	X						X				
FR				X				X	X		
GB	X							X	X		
GR	X							X	X		
HU	X						X		X	X	
IE	X							X	X		
IS											
IT	X							X			
LT ^a											
LU			X								
LV ^a											
MT ^a											
NL	X ^b	X					X		X		
NO							X				
PL ^a											
PT	X							X	X		
RO											
SE	X						X				
SI	X				X	X	X	X	X		X
SK ^a											

^{a)} Information on categories to be supplied by new CEN member.
^{b)} Categories applicable only to certain types of appliance, submitted to on site EC verification procedure, Annex II, article 6 of the Gas Appliance Directive (90/396/EEC) (Netherlands to clarify if applicable here).

Table A.2 — Category II (double) categories marketed

Country	II _{1a2H}	II _{2H3B/P}	II _{2H3+}	II _{2H3P}	II _{2H3B}	II _{2L3B/P}	II _{2L3P}	II _{2E3B/P}	II _{2E3+B/P}	II _{2E+3+}	II _{2E+3P}	II _{2R3R}
AT		X										
BE												
BG												
CH		X	X	X								
CY ^a												
CZ		X		X								
DE								X				
DK	X	X										
EE ^a												
ES			X ^b	X								
FI		X										
FR										X	X	
GB			X	X								
GR		X	X	X								
HU		X		X	X							
IE			X	X								
IS												
IT	X		X									
LT ^a												
LU												
LV ^a												
MT ^a												
NL						X	X					
NO												
PL ^a												
PT			X	X								
RO												
SE	X	X										
SI		X	X	X								X
SK ^a												

^{a)} Information on categories to be supplied by new CEN member.

^{b)} Appliances of this category set for Group H gases of the second family may use air and commercial propane gas mixtures where the gross Wobbe index (at 15 °C and 1 013,25 mbar) is between 46 MJ/m³ and 51,5 MJ/m³, at the same supply pressure, without additional tests.

A.1 Appliance supply pressures corresponding to the categories given in A.2

Table A.3 gives the conditions in the various countries concerning the supply pressures to appliances in the categories given in A.2.

Other, higher supply pressures may be necessary and such pressures may be provided after consultation with the appropriate gas supplier(s) in the country(ies) concerned.

Table A.3 — Normal supply pressures

Gas Pressure (mbar)	G 110		G 20		G 25		G 20 + G 25		G 30		G 31			G 30 + G 31	
	8	20	20	25	Couple 20/25		30 28-30	50	30	37	50	Couple 28-30/37		Couple 50/67	
Country															
AT		X						X			X				
BE						X					x	X	X		
BG															
CH		X						X			X	X			
CY ^{a)}															
CZ		X ^{b)}						X ^{c)}	X	X	X ^{d)}				
DE		X	X				x	X			X				
DK	X	X							X						
EE ^{a)}															
ES		X					x			X	x	X			
FI		X					X		X						
FR						X	x	x		x	x	X			
GB		X ^{e)}					X			X	x	X			
GR		X					X		X	X	X	x			
HU		X ^{f)}					x	x	x		x				
IE		X					x			X		X			
IS															
IT	X	X											X		
LT ^{a)}															
LU		x													
LV ^{a)}															
MT ^{a)}															
NL				X					X		X				
NO							X		X						
PL ^{a)}															
PT		X					X			X		X			
RO															
SE	X	X					X		X						
SI		X					X			X		X			
SK ^{a)}															

- a) Information on supply pressures to be supplied by new CEN member.
b) Currently 18 mbar.
c) For certain types of industrial appliances (CZ to clarify).
d) For certain types of appliances (CZ to clarify).
e) Normal supply pressure for this appliance: 17,5 mbar.
f) Pressures of 25 mbar and 85 mbar.

A.2 Special categories marketed nationally or locally

A.2.1 General

The national or local conditions of gas distribution (gas composition and supply pressures) lead to the definition of special categories which are marketed nationally or locally in certain countries, as shown in Table A.4.

Table A.4 — Test gases corresponding to categories marketed nationally or locally

Category	Reference gas	Incomplete combustion limit gas	Light back limit gas	Lift limit gas	Sooting limit gas	Country
I _{2Esi} , I _{2Er}	G 20, G 25	G 21	G 222	G 231	G 21	FR
I _{2E(S)B}	G 20, G 25	G 21	G 222	G 231	G 21	BE
I _{2E(R)B}	G 20, G 25	G 21	G 222	G 231	G 21	BE
I _{2ELL}	G 20, G 25	G 21	G 222	G 231, G 271	G 21	DE
I _{2S}	G 25.1	G 26.1	G 222	G 27.1	G 26.1	HU ^a
I _{2HS}	G 20, G 25.1	G 21 G 26.1	G 222	G 27.1	G 21, G 26.1	HU ^a
II _{2Esi3+} II _{2Er3+}	G 20, G 25 G 30	G 21	G 222 G 32	G 231 G 31	G 30	FR
II _{2Esi3P} II _{2Er3P}	G 20, G 25 G 31	G 21	G 222 G 32	G 231 G 271	G 31 G 32	FR
II _{2ELL3B/P}	G 20, G 25, G 30	G 21, G30	G 222, G 32	G 231 G 271	G 30	DE
II _{2S3B/P}	G 25.1, G 30	G 26.1, G 30	G 32	G 27.1 G31	G 26.1, G 30	HU ^a
II _{2S3P}	G25.1, G 31	G 26.1, G 30	G 32	G 27.1, G 31	G 26.1, G 31, G32	HU ^a
II _{2S3B}	G 25.1, G30	G 26.1, G30	G 32	G 27.1, G31	G 26.1, G 30	HU ^a
II _{2HS3B/P}	G 20, G 25.1 G 30	G 21, G26.1, G 30	G 222 G 32	G 23, G27.1, G 31	G 21, G 26.1, G 30	HU ^a
II _{2HS3P}	G 20, G 25.1 G 31	G 21, G 26.1, G 30	G 222 G 32	G 23, G 271, G 31	G 21, G 26.1, G 31, G 32	HU ^a
II _{2HS3B}	G 20, G 25.1 G 30	G 21, G 26.1, G 30	G 222 G 32	G 23, G 271, G 31	G 21, G 26.1, G 30	HU ^a
III _{1a2H3B/P}	G 110, G 20 G 30	G 21	G 112 G 222, G 32	G 23 G 31	G 30	DK, IT

Table A.4 (concluded)

Category	Reference gas	Incomplete combustion limit gas	Light back limit gas	Lift limit gas	Sooting limit gas	Country
III _{1c2E+3+}	G 130, G 20 G 30	G 21	G 132 G 222, G 32	G 231 G 31	G 30	FR
III _{1c2E+3P}	G 130, G 20 G 31	G 21	G 132 G 222, G 32	G 231 G 31	G 32	FR
III _{1c2Esi3+} III _{1c2Er3+}	G 130, G 20 G 25, G 30	G 21	G 132 G 222, G 32	G 231 G 31	G 30	FR
III _{1c2Esi3P} III _{1c2Er3P}	G 130, G 20 G 25, G 31	G 21	G 132 G 222, G 32	G 231 G 31	G 32	FR
III _{1ab2H3B/P}	G 110, G 120 G 20, G 30	G 21	G 112 G 222, G 32	G 23 G 31	G 30	SE
^a Hungary to confirm selection.						

A.2.2 Definition of special categories

The definitions of the special categories given in Table A.4 are derived in the same way as those categories listed in 4.2. The characteristics of the gases distributed regionally are given in A.5.

A.2.2.1 Category I

A.2.2.1.1 Systems designed for the use of gases linked to the first family

Category I_{1b}: systems using only gases of Group B linked to the first family, at a fixed supply pressure (this category is not used).

Category I_{1c}: systems using only gases of Group C linked to the first family, at a fixed supply pressure (this category is not used).

Adjustment of the gas rate is optional for the replacement of a gas of one group to a gas of another group within the first family and of the gases which are linked to it.

A.2.2.1.2 Systems designed for the use of gases of the second family and the gases linked to it

Category I_{2Esi}: systems capable of using only gases of Group E of the second family, and operating under the appropriate pressure of a pressure couple. The replacement of a gas in the range Es of Group E (Wobbe index between 44,8 MJ/m³ and 54,7 MJ/m³) by a gas in the range Ei of Group E (Wobbe index in the range 40,9 MJ/m³ and 44,8 MJ/m³) or vice versa necessitates a modification to the burner setting and possibly a change of injectors, of calibrated orifices and of the atmosphere control device.

Category I_{2Er}: systems capable of using only gases of Group E of the second family and being able to operate with a pressure couple without adjustment on the system. However, specific adjustment of the burner gas rate is optional for the replacement of a gas of the range Es of Group E (Wobbe index between 44,8 MJ/m³ and 54,7 MJ/m³) by a gas of the range Ei of Group E (Wobbe index between 40,9 MJ/m³ and 44,8 MJ/m³). If this adjustment has been carried out, a re-adjustment to the previous setting is then necessary in order to return to the use of a gas in the range Es of Group E.

Category I_{2LL}: systems using only gases of Group LL linked to the second family, at a fixed supply pressure. On condition that the Wobbe index of the second family gas distributed does not exceed the

upper limit of 43,7 MJ/m³, the system may be adjusted according to a lower nominal value (this category is not used).

Category I_{2ELL}: systems capable of using gases of Group E of the second family, and gases of Group LL linked to the second family. The gases of Group E of the second family are used under the same conditions as for category I_{2E}. The gases of Group LL of the second family are used under the same conditions as for category I_{2LL}.

Category I_{2S}: systems using only gases of Group S linked to the second family, at the defined supply pressure.

Category I_{2HS}: systems using only gases of Group H of the second family and gases of Group S linked to the second family. The Group H second family gases are used under the same conditions as for category I_{2H}. The Group S second family gases are used under the same conditions as for category I_{2S}.

A.2.2.2 Category II

A.2.2.2.1 Systems designed to use gases of the first family or that are linked to it and gases of the second family or that are linked to it

Category II_{1c2H}: systems capable of using gases of Group C linked to the first family and gases of Group H of the second family. The gases linked to the first family are used under the same conditions as for category I_{1c}. The second family gases are used under the same conditions as for category I_{2H}.

A.2.2.2.2 Systems designed to use of gases of the second family or that are linked to it and gases of the third family

Category II_{2Esi3+}: systems capable of using gases of Group E of the second family and gases of the third family. The second family gases are used under the same conditions as for category I_{2Esi}. The third family gases are used under the same conditions as for category I₃₊.

Category II_{2Esi3P}: systems capable of using gases of Group E of the second family and gases of Group P of the third family. The second family gases are used under the same conditions as for category I_{2Esi}. The gases of the third family are used under the same conditions as for category I_{3P}.

Category II_{2Er3+}: systems capable of using gases of Group E of the second family and gases of the third family. The second family gases are used under the same conditions as for category I_{2Er}. The gases of the third family are used under the same conditions as for category I₃₊.

Category II_{2Er3P}: systems capable of using gases of Group E of the second family and gases of Group P of the third family. The second family gases are used under the same conditions as for category I_{2Er}. The gases of the third family are used under the same conditions as for category I_{3P}.

Category II_{2ELL3B/P}: systems capable of using gases of Group E of the second family, gases of Group LL linked to the second family and gases of the third family. The second family gases or the gases that are linked to it are used under the same conditions as for category I_{2ELL}. Gases of the third family are used under the same conditions as for category I_{3B/P}.

Category II_{2S3B/P}: systems capable of using gases of Group S linked to the second family and gases of the third family. The gases linked to the second family are used under the same conditions as for category I_{2S}. The third family gases are used under the same conditions as for category I_{3B/P}.

Category II_{2S3P}: systems capable of using gases of Group S linked to the second family and gases of Group P of the third family. The gases linked to the second family are used under the same conditions as for category I_{2S}. The third family gases are used under the same conditions as for category I_{3P}.

Category II_{2S3B}: systems capable of using gases of Group S linked to the second family and gases of Group B of the third family. The gases linked to the second family are used under the same conditions as for category I_{2S}. The third family gases are used under the same conditions as for category I_{3B}.

Category II_{2HS3B/P}: systems capable of using gases of Group H of the second family, gases of Group S linked to the second family and gases of the third family. Gases of the second family or gases linked to it are used under the same conditions as for category I_{2HS}. The third family gases are used under the same conditions as for category I_{3B/P}.

Category II_{2HS3P}: systems capable of using gases of Group H of the second family, gases of Group S linked to the second family and gases of Group P of the third family. Gases of the second family or gases linked to it are used under the same conditions as for category I_{2HS}. The third family gases are used under the same conditions as for category I_{3P}.

Category II_{2HS3B}: systems capable of using gases of Group H of the second family, gases of Group S linked to the second family and gases of Group B of the third family. Gases of the second family or gases linked to it are used under the same conditions as for category I_{2HS}. The third family gases are used under the same conditions as for category I_{3B}.

A.2.2.3 Category III

Category III_{1a2H3B/P}: systems capable of using gases of Group A of the first family, gases of Group H of the second family and gases of the third family. The first family gases are used under the same conditions as for category I_{1a}. The second family gases are used under the same conditions as for category I_{2H}. The third family gases are used under the same conditions as for category I_{3B/P}.

Category III_{1c2H3B/P}: systems capable of using gases of Group C linked to the first family, gases of Group H of the second family and gases of the third family. The first family gases are used under the same conditions as for category I_{1c}. The second family gases are used under the same conditions as for category I_{2H}. The third family gases are used under the same conditions as for category I_{3B/P}.

Category III_{1c2H3+}: systems capable of using gases of Group C linked to the first family, gases of Group H of the second family and gases of the third family. The first family gases are used under the same conditions as for category I_{1c}. The second family gases are used under the same conditions as for category I_{2H}. The third family gases are used under the same conditions as for category I₃₊.

Category III_{1c2H3P}: systems capable of using gases of Group C linked to the first family, gases of Group H of the second family and gases of the third family. The first family gases are used under the same conditions as for category I_{1c}. The second family gases are used under the same conditions as for category I_{2H}. The third family gases are used under the same conditions as for category I_{3P}.

Category III_{1c2E+3+}: systems capable of using gases of Group C linked to the first family, gases of Group E of the second family and gases of the third family. The gases linked to the first family are used under the same conditions as for category I_{1c}. The second family gases are used under the same conditions as for category I_{2E+}. The third family gases are used under the same conditions as for category I₃₊.

Category III_{1c2E+3P}: systems capable of using gases of Group C linked to the first family, gases of Group E of the second family and gases of Group P of the third family. The gases linked to the first family are used under the same conditions as for category I_{1c}. The second family gases are used under the same conditions as for category I_{2E+}. The third family gases are used under the same conditions as for category I_{3P}.

Category III_{1c2Esi3+}: systems capable of using gases of Group C linked to the first family, gases of Group E of the second family and gases of the third family. The gases linked to the first family are used under the same conditions as for category I_{1c}. The second family gases are used under the same conditions as for category I_{2Esi}. The third family gases are used under the same conditions as for category I₃₊.

Category III_{1c2Esi3P}: systems capable of using gases of Group C linked to the first family, gases of Group E of the second family and gases of the third family. The gases linked to the first family are used under the same conditions as for category I_{1c}. The second family gases are used under the same conditions as for category I_{2Esi}. The third family gases are used under the same conditions as for category I_{3P}.

Category III_{1c2Er3+}: systems capable of using gases of Group C linked to the first family, gases of Group E of the second family and gases of the third family. The gases linked to the first family are used under the same conditions as for category I_{1c}. The second family gases are used under the same conditions as for category I_{2Er}. The third family gases are used under the same conditions as for category I₃₊.

Category III_{1c2Er3P}: systems capable of using gases of Group C linked to the first family, gases of Group E of the second family and gases of Group P of the third family. The gases linked to the first family are used under the same conditions as for category I_{1c}. The second family gases are used under the same conditions as for category I_{2Er}. The third family gases are used under the same conditions as for category I_{3P}.

Category III_{1ab2H3B/P}: systems capable of using gases of Group A of the first family, gases of Group B linked to the first family, gases of Group H of the second family and gases of the third family. The first family gases or the gases linked to it are used under the same conditions as for categories I_{1a} and I_{1b}. The second family gases are used under the same conditions as for category I_{2H}. The third family gases are used under the same conditions as for category I_{3B/P}.

A.2.3 Gas rate adjusters, aeration adjusters and regulators

This clause has been included to enable CEN members to provide information equivalent to that given in 5.2.2, 5.2.3, 5.2.4 and 5.2.6 in relation to the special categories they have requested, detailed in A.4.1.

A.2.4 Conversion to different gases

This clause has been included to enable certain member states to provide information equivalent to that given in 5.1.1.1 in relation to the special appliance categories listed in A.4.1.

A.3 Test gases corresponding to the special categories given in A.4

The characteristics of the test gases corresponding to the gases distributed nationally or locally and the corresponding test pressures are given in Table A.5 (reference conditions only).

Mixtures of gases of Group A with gases of Groups C or E, where the Wobbe index is between 21,1 MJ/m³ and 24,8 MJ/m³ are also linked to Group A of the first family.

These mixtures may only be used without supplementary tests in appliances in multiple categories including Group A of the first family.

Table A.5 — Test gases corresponding to local situations

Gas family and group		Nature of gas	Designation	Composition Volume %	WI MJ/m ³	HI MJ/m ³	Ws MJ/m ³	Hs MJ/m ³	d	Test Pressure mbar	Country
Gases linked to the first family	Group B	Reference Incomplete combustion Sooting	G 120	H ₂ = 47 CH ₄ = 32 N ₂ = 21	24,40	15,68	27,64	17,77	0,413	$\rho_n = 8$ $\rho_{min} = 6$	SE
		Light back	G 112	H ₂ = 59 CH ₄ = 17 N ₂ = 24	19,48	11,81	22,36	13,56	0,367	$\rho_{max} = 15$	
	Group C	Reference (Propane-air)	G 130	C ₃ H ₈ = 26,9 Air = 73,1 ^{a)}	22,14	23,66	24,07	25,72	1,142	$\rho_n = 8$ $\rho_{min} = 6$ $\rho_{max} = 15$	FR
		Light back	G 132	C ₃ H ₈ = 13,8 C ₃ H ₆ = 13,8 Air ^{b)} = 72,4	22,10	23,56	23,84	25,41	1,136		
Gases linked to the second family	Group LL	Reference	G 25 ²⁾	CH ₄ = 86 N ₂ = 14	37,38	29,25	41,52	32,49	0,612	$\rho_n = 20$	DE
		Incomplete combustion Sooting	G 26	CH ₄ = 80 C ₃ H ₈ = 7 N ₂ = 13	40,52	33,36	44,83	36,91	0,678	$\rho_{min} = 18$	
		Flame lift	G 271	CH ₄ = 74 N ₂ = 26	30,94	25,17	34,36	27,96	0,662	$\rho_{max} = 25$	
	Group S	Reference	G 25.1	CH ₄ = 86 CO ₂ = 14	35,25	29,30	39,11	32,51	0,691	$\rho_n = 25$ $\rho_{min} = 20$	HU
		Incomplete combustion Sooting	G 26.1	CH ₄ = 80 C ₃ H ₈ = 6 CO ₂ = 14	37,61	32,60	41,58	36,04	0,751	$\rho_{max} = 33$	
		Lift limit	G 27.1	CH ₄ = 82 CO ₂ = 18	32,70	27,94	36,29	31,00	0,730	$\rho_n = 85$ $\rho_{min} = 73$ $\rho_{max} = 100$	
Gases of the second family	Range of Es of Group E	Reference	G 20 ^{b)}	CH ₄ = 100	45,67	34,02	50,72	37,78	0,555	$\rho_n = 20$	FR
		Incomplete combustion Sooting	G 21	CH ₄ = 87 C ₃ H ₈ = 13	49,60	41,01	54,76	45,28	0,684	$\rho_{min} = 17$	
		Light back	G 222	CH ₄ = 77 H ₂ = 23	42,87	28,53	47,87	31,86	0,443		
	Group E	Lift limit	G 26	CH ₄ = 80 C ₃ H ₈ = 7 N ₂ = 13	40,52	33,36	44,83	36,91	0,678	$\rho_{max} = 25$	
		Reference	G 25 ²⁾	CH ₄ = 86 N ₂ = 14	37,38	29,25	41,52	32,49	0,612	$\rho_n = 25$	
	Range of Ei of Group E	Incomplete combustion Sooting	G 26	CH ₄ = 80 C ₃ H ₈ = 7 N ₂ = 13	40,52	33,36	44,83	36,91	0,678	$\rho_{min} = 20$	
		Lift limit	G 231	CH ₄ = 85 N ₂ = 15	36,82	28,91	40,90	32,11	0,617	$\rho_{max} = 30$	

^{a)} Composition of the air (%): O₂ = 20,95; N₂ = 79,05.

^{b)} For the characteristics of the reference gases G 20 and G 25, see Table 4.

A.4 Gas connections in the various countries

Table A.6 shows the national situations concerning the various types of gas connection specified in 5.1.6.

Table A.6 — Permitted inlet connections

Country	Category I ₃₊ , I _{3P} , I _{3B} , I _{3B/P}			Other categories		
	Threaded connections		Other connections	Threaded connections		Other connections
	EN 10226-1 :2004 and EN 10226-2 :1995	EN ISO 228-1: 2003		EN 10226-1 :2004 and EN 10226-2 :1995	EN ISO 228-1: 2003	
AT	Yes	—	Yes	Yes	—	—
BE	Yes	Yes	Yes	—	Yes	—
BG	—	—	—	—	—	—
CH	Yes	Yes	Yes	Yes	Yes	—
CY	—	—	—	—	—	—
CZ	—	—	—	—	—	—
DE	Yes	—	Yes	Yes	—	—
DK	Yes	Yes	Yes	—	Yes	—
EE	—	—	—	—	—	—
ES	—	—	—	—	—	—
FI	Yes	Yes	Yes	Yes	Yes	—
FR	—	Yes	Yes	—	Yes	—
GB	Yes	—	Yes	Yes	—	Yes
GR	Yes	—	Yes	Yes	—	—
HU	—	—	—	—	—	—
IE	Yes	—	Yes	Yes	—	Yes
IS	—	—	—	—	—	—
IT	Yes	—	Yes	Yes	—	—
LU	—	—	—	—	—	—
LV	—	—	—	—	—	—
MT	—	—	—	—	—	—

NL	Yes	—	—	Yes	—	—
NO	Yes	Yes	Yes	—	—	—
PL	—	—	—	—	—	—
PT	Yes	Yes	Yes	Yes	Yes	Yes
RO	—	—	—	—	—	—
SE	—	—	—	—	—	—
SI	Yes	Yes	Yes	Yes	Yes	Yes
SK	Yes	Yes	—	Yes	Yes	—

A.5 Flue connections in the various countries

Table A.7 shows the national situations concerning the diameters of standard flue pipes.

Table A.7 — Standard flue pipe diameters

Country	Standard flue pipe diameters (external) in mm																
AT	60	70	80	90	100	110	120	130	140	150	160	180	200				
BE	All diameters acceptable																
BG																	
CH	60	70	80	90	100	110	120	130	150	160	170	180	200				
CY																	
CZ																	
DE	60	70	80	90	100	110	120	130	150	200							
DK	Diameters not standardized																
EE																	
ES																	
FI	90	100	110	130	150	180	200										
FR	66	83	97	111	125	139	153	167	180								
GB	76	102	127	153	metal pipes (all 0, - 1 tolerance)												
GR	60	70	80	90	100	110	120	130	150	180	200						
HU																	
IE	76	102	127	153	metal pipes (all 0, - 1 tolerance)												
	84	109	137	162	fibrous cement pipes (all ± 3 tolerance)												
IS																	
IT	60	80	100	110	120	150											
LT																	
LU																	
LV																	
MT																	
NL	60	70	80	90	100	110	130	150	180	200							
NO																	
PL																	
PT	60	85	90	95	105	110	115	120	125	130	135	145	155	205	255	305	355
SE																	
SI	60	70	80	90	100	110	120	130	140	150	160	180	200				
SK																	

Annex B
(informative)

System D

B.1 Type D systems

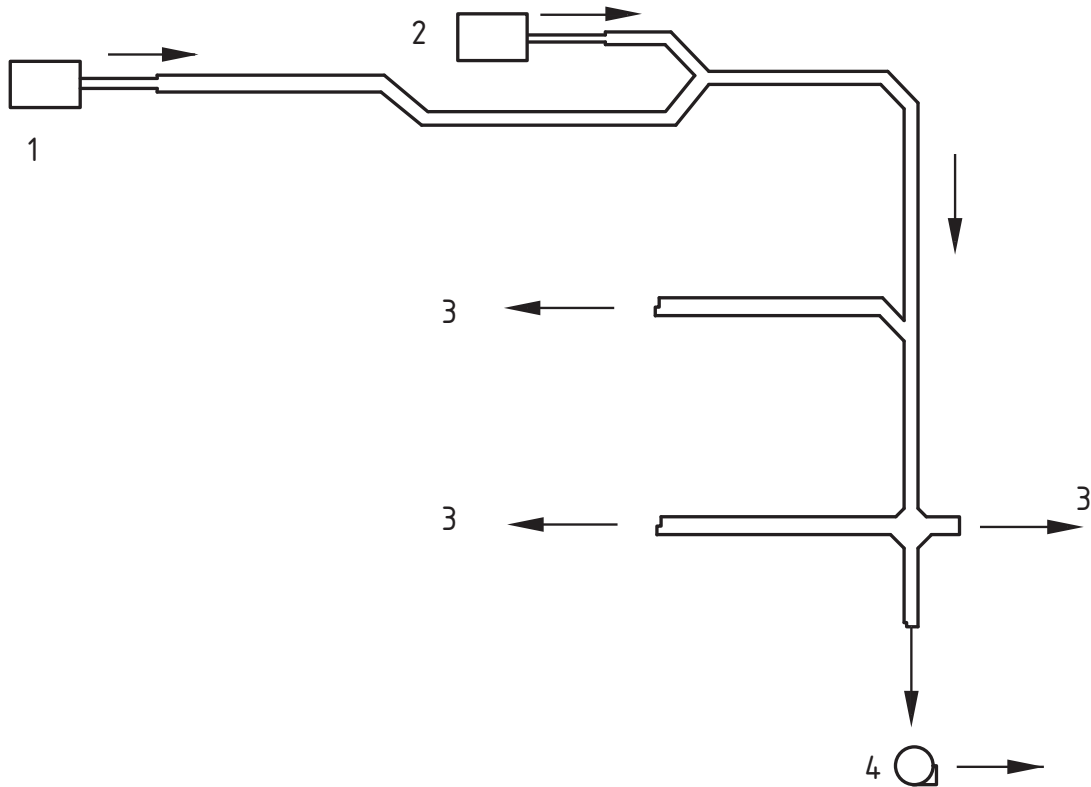

- Key**
- 1 Burner 1
 - 2 Burner 2
 - 3 Branch tube
 - 4 Fan

a) Typical system D₁

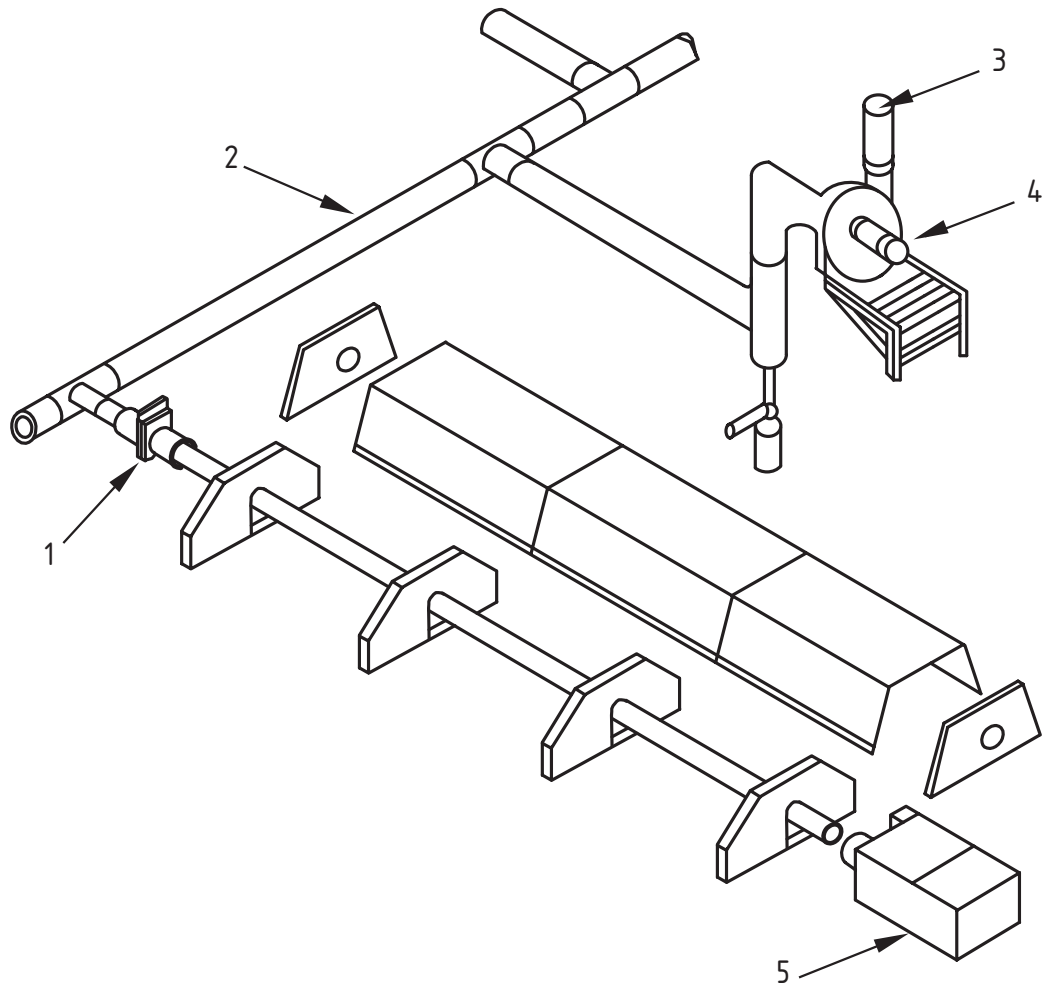

- Key**
- 1 Damper
 - 2 Common duct
 - 3 Flue
 - 4 Fan
 - 5 Burner

b) Typical system D₂

Figure B.1 — Type D Systems

Annex C (informative)

Equivalence rules

C.1 Conversion to categories within a restricted Wobbe Index range

Any system belonging to one category may be categorized as a system belonging to another category covering a more restricted range of Wobbe Index provided that the requirements of 5.1.1, 5.2.2, 5.2.3 and 5.2.6 are satisfied, that its state of conversion corresponds to that of the country (or countries) of destination and that the information provided on the system corresponds to its adjustment.

In principle, this equivalence is recognized without the system having to be submitted to new tests. However, supplementary tests may be necessary using the pressures and the test gases currently in force in the intended country (or countries) of destination:

- a) when the supply pressures are different in the country (or countries) for which the system has been tested from those in the intended country of destination; or
- b) when a system fitted with adjusters⁸, even though sealed, has been tested under the conditions of the original category with test gases different from those of the country where it is to be sold; or
- c) when the requirements for regulators (see 5.2.6) with respect to the existing category differ from those of the new category.

In all cases these supplementary tests are at most those stated in 7.1.5.1.

EXAMPLE 1: A system in category I_{2E} for G 20 at 20 mbar may be categorized as a system in category I_{2H} for G 20 at 20 mbar without additional tests.

If, however, the pressures are different, the tests specified in 7.1.5.1 are carried out, after changing the injectors, if necessary.

EXAMPLE 2: A system in category I_{2E+} for G 20 at 20 mbar may be categorized as a system in category I_{2H} for G 20 at 20 mbar provided that it satisfies the corresponding tests given in 7.1.5.1 after changing the injectors, if necessary, and after adjusting the regulator in accordance with 5.2.6.

C.2 Conversion to categories within an identical Wobbe Index range

Any system belonging to one category may be categorized as a system belonging to another category covering a more restricted range of Wobbe Index provided that the requirements of 5.1.1, 5.2.2, 5.2.3 and 5.2.6 are satisfied, that its state of conversion corresponds to that of the country (or countries) of destination and that the information provided on the system corresponds to its adjustment.

In principle, this equivalence is recognized without the system having to be submitted to new tests. However, supplementary tests may be necessary using the pressures and the test gases currently in force in the intended country (or countries) of destination:

⁸ Throughout Annex C the word "adjuster" refers to gas rate adjusters and to fixed primary aeration adjusters as appropriate.

- a) when the supply pressures are different in the country (or countries) for which the system has been tested from those in the intended country of destination; or
- b) when a system fitted with adjusters⁹⁾ even though sealed, has been tested under the conditions of the original category with test gases different from those of the country where it is to be sold; or
- c) when the requirements for regulators (see 5.2.6) with respect to the existing category differ from those of the new category.

In all cases these supplementary tests are at most those stated in 7.1.5.1.

EXAMPLE 1: A system in category I_{2E+} may be categorized as a system in category I_{2Esi} or I_{2Er} provided that it satisfies the tests specified in 7.1.5.1 for the test pressures and the test gases relating to category I_{2Esi} or I_{2Er} ⁹⁾ and with the corresponding injectors and adjustments. These adjustments take into account the requirements of 5.2.6.

EXAMPLE 2: A system in category I_{Esi} or I_{2Er} may be categorized as a system in category I_{2E+} provided that it satisfies the tests specified in 7.1.5.1 for the test pressures corresponding to category I_{2E+} ⁹⁾. In addition, any adjusters are locked and sealed in the appropriate positions, taking account of the requirements of 5.2.6.

C.3 Conversion to categories within a wider Wobbe Index range

A system belonging to one category may be categorized as a system in another category covering a wider range of Wobbe Index if it complies with all the constructional requirements of the proposed new category.

In addition, the system is submitted to the tests specified in 7.1.5.1 using the test gases and test pressures for the proposed new category. Where appropriate, account should be taken of the special conditions given in Annex G.

⁹⁾ Where the intended country of destination is Belgium, account should be taken of the special national conditions given in Annex G.

Annex D (informative)

Calculation of the mass flow rate of flue gases

D.1 Flue gas mass flow rate

The mass flow rate (M_{fg}) of flue gas is calculated using Equation D.1 (also see Table D.1).

$$M_{fg} = (m_{H_2O} + m_{N_2} + m_{O_2} + m_{CO_2}) \times \frac{Q}{3600H_i} \quad (D.1)$$

where:

- M_{fg} is the flue gas mass flow rate (kg/s);
- m_{H_2O} is the quantity of water vapour, H_2O (kg/m³);
- m_{N_2} is the quantity of nitrogen, N_2 (kg/m³);
- m_{O_2} is the quantity of oxygen, O_2 (kg/m³);
- m_{CO_2} is the quantity of carbon dioxide, CO_2 (kg/m³);
- Q is the measured heat input (kW);
- H_i is the net calorific value (kWh/m³).

D.2 Quantity of air in the flue gas

The quantity of air in the flue gas (L) is calculated using Equation D.2.

$$L = L_{min} + V_{at} \left(\frac{V_{CO_2N}}{V_{CO_2M}} - 1 \right) \quad (D.2)$$

where:

- L is the quantity of air in the flue gas (m³/m³);
- L_{min} is the air requirement (m³/m³);
- V_{at} is the quantity of dry flue gas (m³/m³);
- V_{CO_2N} is the calculated carbon dioxide content (%) of the dry, air-free products of combustion;
- V_{CO_2M} is the carbon dioxide concentration (%) measured in the sample during the combustion test.

D.3 Flue gas excess air ratio (λ)

The excess air ratio (λ) in the flue gas is calculated using Equation D.3.

$$\lambda = \frac{L}{L_{\min}} \quad (\text{D.3})$$

where:

λ is the excess air ratio in the flue gas;

L is the quantity of air in the flue gas (m^3/m^3);

L_{\min} is the air requirement (m^3/m^3).

D.4 Quantity of water vapour in the flue gas

The quantity of water vapour ($m_{\text{H}_2\text{O}}$) in the flue gas is calculated using Equation D.4.

$$m_{\text{H}_2\text{O}} = 0,854 (V_{\text{af}} - V_{\text{at}}) \quad (\text{D.4})$$

where:

$m_{\text{H}_2\text{O}}$ is the quantity of water vapour in the flue gas (kg/m^3);

V_{at} is the quantity of dry flue gas (m^3/m^3);

V_{af} is the quantity of wet flue gas (m^3/m^3).

D.5 Quantity of Nitrogen in the flue gas

The quantity of nitrogen (m_{N_2}) in the flue gas is calculated using Equation D.5.

$$m_{\text{N}_2} = 0,79 \times 1,25 \lambda \times L_{\min} \quad (\text{D.5})$$

where:

m_{N_2} is the quantity of nitrogen in the flue gas (kg/m^3);

λ the excess air ratio in the flue gases is 1;

L_{\min} is the air requirement (m^3/m^3).

D.6 Quantity of Oxygen in the flue gas

The quantity of oxygen (m_{O_2}) in the flue gas is calculated using Equation D.6.

$$m_{\text{O}_2} = 0,21 \times 1,429 (\lambda - 1) L_{\min} \quad (\text{D.6})$$

where:

- m_{O_2} is the quantity of oxygen in the flue gas (kg/m^3);
- λ the excess air ratio in the flue gases is 1;
- L_{\min} is the air requirement (m^3/m^3).

D.7 Dry quantity of flue gas

The dry quantity of flue gases with excess air ratio (V_t) is calculated using Equation D.7.

$$V_t = V_{\text{at}} + (\lambda - 1) L_{\min} \quad (\text{D.7})$$

where:

- V_t is the dry quantity of flue gas (kg/m^3);
- V_{at} is the quantity of dry flue gas (m^3/m^3);
- λ the excess air ratio in the flue gases is 1;
- L_{\min} is the air requirement (m^3/m^3).

D.8 Quantity of carbon dioxide in the flue gas

The quantity of carbon dioxide (m_{CO_2}) in the flue gas is calculated using Equation D.8.

$$m_{CO_2} = 1,977 \left(V_t - \left(\frac{m_{N_2}}{1,25} + \frac{m_{O_2}}{1,429} \right) \right) \quad (\text{D.8})$$

where:

- m_{CO_2} is the quantity of carbon dioxide in the flue gas (kg/m^3);
- m_{N_2} is the quantity of nitrogen in the flue gas (kg/m^3);
- m_{O_2} is the quantity of oxygen in the flue gas (kg/m^3);
- V_t is the dry quantity of flue gas (kg/m^3).

Table D.1 — Characteristic values for flue gas mass flow rate calculations

Gas		Quantity of flue gases ($\lambda - 1$) m ³ /m ³		V _{CO2N} %	Air requirement ($\lambda = 1$)	Net calorific value
		dry V _{at}	wet V _{af}		L _{min} m ³ /m ³	H _i kWh/m ³
First family	Group A (G 110)	3,40	4,42	7,66	3,66	4,09
	Group b (G 120)	3,82	4,93	8,37	4,16	5,59
Second family	Group L/LL (G 25)	7,46	9,18	11,51	8,19	8,57
	Group H/E (G 20)	8,52	10,52	11,73	9,52	9,97
Third family	Group B/P (G 30)	28,45	33,45	14,06	30,95	34,39
	G 31	21,8	25,8	13,8	23,8	25,9

Annex E (informative)

Identification of the types of gas in use in various countries

Table E.1 — Means of identification of gas types in use in various countries

Type of gas	G 110	G 120	G 130	G 150	G 20	G 25	G 30	G 31
Country code ²⁾								
AT					Erdgas		Flüssiggas	
BE					Aardgas, naturel	Gaz Aardgas, Gaz naturel	Butaan, Butane	Propaan, Propane
CH			Propan- Luft Butan-Luft		Erdgas H		Butan	Propan
CY								
CZ								
DE					Erdgas E W _o (12,0 – 15,7) kWh/m ³ 0 °C	Erdgas LL W _o (10,0 – 13,1) kWh/m ³ 0 °C	Flüssiggas B/P Butan	Propan
DK	Bygas				Naturgas		F-Gas	F-Gas
EE								
ES	Gas manufacturado		Aire propanado	Aire metanado	Gas natural		Butano	Propano
FI					Maakaasu, Naturgas		Butaani, Butan	Propaani, Propan
FR ¹⁾			Air propané/ Air butané		Gaz naturel Lacq	Gaz naturel Groningue	Butane	Propane
GB					Natural Gas		Butane	Propane
GR					Φυσικό Αέριο		Υγραέριο Μείγμα	Προπάνιο
HU								
IE					Natural Gas		Butane	Propane
IS								
IT	Gas di Città				Gas naturale/ Gas metano		GPL	
LT								
LU								
LV								
MT								
NL						Aardgas	Butaan	Propaan
NO							Butan	Propan
PL								
PT					Gás Natural		Butano	Propano
SE								
SI					Zemeljski plin		Utekočinjeni naftni plin (UNP) Butan	Propan
SK								

¹⁾ The meaning of the symbol corresponding to the type of gas shall be explained in detail in the technical instructions. Concerning the system and its packaging, if an additional marking is intended by the manufacturer to explain the symbol, this text shall be in conformity with the description given in this table. In the case of pressure couples, the two descriptions of the family shall be mentioned.

²⁾ See E.1.4 for codes.

Annex F (normative)

Special national conditions

F.1 General

Special national conditions are national characteristics or practice that cannot be changed even over a long period (e.g. climatic conditions, electrical earthing conditions). If it affects harmonization, it forms part of the European Standard or Harmonization Document.

For the countries in which the relevant special national conditions apply these provisions are normative, for other countries they are informative.

F.1.1 Belgium

Appliances of categories I_{2E+}, I_{2E(R)B} and I_{2E(S)B} marketed in Belgium have to undergo a test for ignition, crosslighting and flame stability with the limit gas G 231 at the minimum pressure of 15 mbar.

F.1.2 Italy

Appliances of categories I_{3B/P}, II_{2H3B/P} and III_{1a2H3B/P} without pressure regulators marketed in Italy shall have successfully undergone a test for flame stability with the limit gas G 31 at the pressure of 45 mbar.

Annex G (informative)

Calculation example of the weighting factors for a system with several rates

G.1 Appliance rates

The appliance rates used are 100 %, 50 % and 30 %.

Table G.1 — Weighting $Q_{pi,\%}$ and F_{pi}

$Q_{pi,\%}$ (%)	70	60	40	20
F_{pi}	0,15	0,25	0,3	0,3

G.2 Weighting of $Q_{pi,\%} = 20$

Q_{min} is 30 %, which is larger than 20 %, so the F_{pi} of 20 % is added to the F_{pi} of 30 %.

$$F_{pi}(30\%) = 0,3$$

G.3 Weighting of $Q_{pi,\%} = 40$

$Q_{pi,\%} = 40$ has to be apportioned between $Q_{pi,\%} = 30$ (low rate) and $Q_{pi,\%} = 50$ (high rate).

$$\text{High rate : } F_{pi}(50\%) = F_{pi}(40\%) \times \frac{Q_{pi,\%} 40 - Q_{pi,\%} 30}{Q_{pi,\%} 50 - Q_{pi,\%} 30} \times \frac{Q_{pi,\%} 50}{Q_{pi,\%} 40}$$

$$F_{pi}(50\%) = 0,3 \times \frac{40 - 30}{50 - 30} \times \frac{50}{40} = 0,1875$$

$$\text{Low rate : } F_{pi}(30\%) = F_{pi}(40\%) - F_{pi}(50\%) = 0,3 - 0,1875 = 0,1125$$

G.4 Weighting of $Q_{pi,\%} = 60$

$Q_{pi,\%} = 60$ has to be apportioned between $Q_{pi,\%} = 50$ (low rate) and $Q_{pi,\%} = 100$ (high rate).

$$\text{High rate : } F_{\text{pi}}(100\%) = F_{\text{pi}}(60\%) \cdot \frac{Q_{\text{pi},\%} 60 - Q_{\text{pi},\%} 50}{Q_{\text{pi},\%} 100 - Q_{\text{pi},\%} 50} \cdot \frac{Q_{\text{pi},\%} 100}{Q_{\text{pi},\%} 60}$$

$$F_{\text{pi}}(100\%) = 0,25 \times \frac{60 - 50}{100 - 50} \times \frac{100}{60} = 0,0833$$

$$\text{Low rate : } F_{\text{pi}}(50\%) = F_{\text{pi}}(60\%) - F_{\text{pi}}(100\%) = 0,25 - 0,0833 = 0,1667$$

G.5 Weighting of $Q_{\text{pi},\%} = 70$

$Q_{\text{pi},\%} = 70$ has to be apportioned between $Q_{\text{pi},\%} = 50$ (low rate) and $Q_{\text{pi},\%} = 100$ (high rate).

$$\text{High rate : } F_{\text{pi}}(100\%) = F_{\text{pi}}(70\%) \times \frac{Q_{\text{pi},\%} 70 - Q_{\text{pi},\%} 50}{Q_{\text{pi},\%} 100 - Q_{\text{pi},\%} 50} \times \frac{Q_{\text{pi},\%} 100}{Q_{\text{pi},\%} 70}$$

$$F_{\text{pi}}(100\%) = 0,15 \times \frac{70 - 50}{100 - 50} \times \frac{100}{70} = 0,0857$$

$$\text{Low rate : } F_{\text{pi}}(50\%) = F_{\text{pi}}(70\%) - F_{\text{pi}}(100\%) = 0,15 - 0,0857 = 0,0643$$

G.6 Total weighting

Table G.2 — Total weighting

Rate	20 %	40 %	60 %	70 %	Total
30 %	0,30	0,112 5	—	—	0,412 5
50 %	—	0,187 5	0,166 7	0,064 3	0,418 5
100 %	—	—	0,083 3	0,085 7	0,169 0
Total	0,30	0,30	0,25	0,15	1

The ponderation is given by Equation G.1.

$$\text{NO}_{\text{x,pond}} = 0,4125 \times \text{NO}_{\text{x,mes}(30\%)} + 0,4185 \times \text{NO}_{\text{x,mes}(50\%)} + 0,169 \times \text{NO}_{\text{x,mes}(100\%)} \quad (\text{G.1})$$

Annex H (informative)

Calculation of conversions of NO_x

H.1 NO_x emission conversion factors

Table H.1 — NO_x emission value conversion for first family gases

		G 110	
		mg/kWh	mg/MJ
O ₂ = 0 %	1 ppm ^{a)}	1,714	0,476
	1 mg/m ^{3 a)}	0,834	0,232
O ₂ = 3 %	1 ppm	2,000	0,556
	1 mg/m ³	0,974	0,270
a) 1 ppm = 2,054 mg/m ³ and 1 ppm = 1 cm ³ /m ³			

Table H.2 — NO_x emission value conversion for second family gases

		G 20		G 25	
		mg/kWh	mg/MJ	mg/kWh	mg/MJ
O ₂ = 0 %	1 ppm ^{a)}	1,764	0,490	1,797	0,499
	1 mg/m ^{3 a)a}	0,859	0,239	0,875	0,243
O ₂ = 3 %	1 ppm	2,059	0,572	2,098	0,583
	1 mg/m ³	1,002	0,278	1,021	0,284
a) 1 ppm = 2,054 mg/m ³ and 1 ppm = 1 cm ³ /m ³					

Table H.3 — NO_x emission value conversion for third family gases

		G 30		G 31	
		mg/kWh	mg/MJ	mg/kWh	mg/MJ
O ₂ = 0 %	1 ppm ^{a)}	1,792	0,498	1,778	0,494
	1 mg/m ^{3 a)a}	0,872	0,242	0,866	0,240
O ₂ = 3 %	1 ppm	2,091	0,581	2,075	0,576
	1 mg/m ³	1,018	0,283	1,010	0,281
a) 1 ppm = 2,054 mg/m ³ and 1 ppm = 1 cm ³ /m ³					

H.2 NO_x Conversion — Calculation

Flowchart for the calculation of the NO_x emission to the reference conditions mg/MJ, mg/kWh and ppm; dry, with a certain amount of O₂.

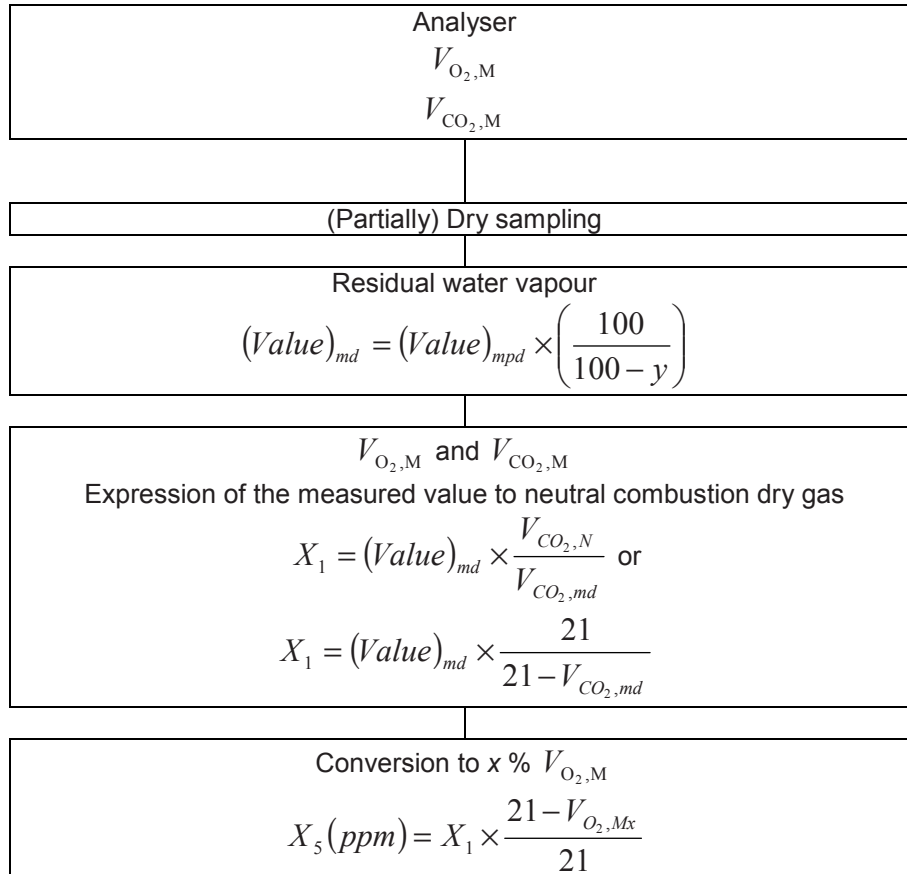

Table H.4 — Relationship of symbols in EN 777-1:2008 and CR 1404:1994

EN 777-1:2008	CR 1404:1994	Explanation
$V_{CO,M}$ $V_{NO_x,M}$ $V_{NO,M}$ $V_{NO_2,M}$	$(CO)_m$ $(NO_x)_m$ $(NO)_m$ $(NO_2)_m$	are measured concentrations in the sample taken during the combustion test (ppm, V/V): $V_{NO_x,M} = V_{NO,M} + V_{NO_2,M}$
$V_{CO_2,M}$ $V_{O_2,M}$	(CO_2) (O_2)	are measured concentrations in the sample taken during the combustion test (% , V/V)
$V_{CO_2,N}$	$(CO_2)_n$	is the maximum carbon dioxide content of the dry, air-free combustion products (% , V/V)
$V_{O_2,md}$ $V_{CO_2,md}$	$(O_2)_{md}$ $(CO_2)_{md}$	is the correction of measured value at partially dry (mpd) sample gas to dry (md) sample gas
y	y	is the content of water vapour in dried sample gas (% , V/V)
x	x	is the reference level of O ₂ dry gas (%) (e.g. 3% O ₂)
X_1	X_1	is the NO _x value at neutral combustion conditions dry gas at 0% O ₂ (ppm, mg/MJ or mg/kWh)
X_5	X_5	is the NO _x value at x % O ₂ dry gas converted from neutral combustion conditions (ppm, mg/MJ or mg/kWh)

Annex I (informative)

National situations of countries whose national bodies are CEN associate members

NOTE This Annex has been retained to enable the current associate members of CEN to provide information concerning any national situations. At present no information has been received from any associate member state of CEN.

Annex J (informative)

An example of sampling plans

J.1 Sampling plans

J.1.1 General

In this example sampling plans are selected from the tables published in ISO 2859-1.

J.1.2 Acceptable quality level (AQL)

In this example the AQL is decided in relation to the nature of the inspection feature being controlled. For defects classed as Major, the sampling plan is based on an AQL of 4,0.

NOTE Classification of defects should be the responsibility of the person responsible for the manufacturing process.

J.1.3 The inspection level

The inspection level defines the relationship between the batch size and the sample size. In this example all incoming goods are subjected to inspection level II.

J.1.4 Normal, tightened or reduced inspection

In this example the normal inspection is used initially on all incoming materials, after which, the following rules apply:

- a) when ten successive batches have been accepted on original there can be a switch to reduced inspection. This should remain in operation until one batch is rejected, at which point normal inspection is resumed;
- b) when two out of any five successive batches have been rejected on original inspection, there can be a switch to tightened inspection. This should remain in operation until five successive batches have been accepted, at which point normal inspection is resumed.

J.1.5 Single, double, multiple or sequential sampling

Unless otherwise specified, all incoming material should be subjected to single sampling plans.

J.1.6 Batch quality

Once the first four variables have been decided, the sampling plan tables should indicate the amount of samples to be inspected for any given batch quantity.

All information regarding levels of inspection should be indicated where appropriate on the inspection records.

J.2 Inspection levels and procedures

J.2.1 Incoming material

In this example sample inspected to ISO 2859-1 using an AQL = 2,5, general inspection level II, single sampling plan for normal inspection incorporating the switching rules to tighten or reduce inspection if necessary. All mill certification should be checked against the relevant technical specification.

J.2.2 In-process aspects

For all dimensional aspects an inspection feature should be introduced each time the material changes form during the process.

A first inspection should be implemented and verified by the setter or supervisor at each machine operation and from then on the operators should carry out each required dimensional check at a rate of four per batch – unrecorded, using go-no go gauges.

For the purposes of this example this is supplemented by a beginning and end of shift full dimensional check by the line supervisor using measuring equipment. This is a record check, a register of all results being maintained.

J.2.3 Finished goods checks

- a) At the end of the manufacturing process, each unit should be visually inspected for damage.
- b) At the warehouse, once a week, the goods inwards inspector should randomly select four samples from a particular product range and subject each item to full dimensional checks. This should also be carried out to a formalised programme.

Annex K (informative)

Flue loss determination

K.1 General conditions of test

K.1.1 Principle of method

The heat loss from a building via the flue system is determined from measurements of CO₂ concentration and the temperature of the products of combustion.

K.1.2 Test room

The room shall be adequately ventilated but free from draughts likely to affect the performance of the system. The room temperature shall be maintained at 20 °C ± 5 °C and, during the course of a test, it shall not vary by more than 2 K.

K.1.3 Preparation of system

The system is installed in accordance with 7.1.6 and operated, in accordance with the manufacturer's instructions, with reference gas (see Table 5) except that system is installed with a combustion products evacuation duct of the maximum equivalent resistance declared by the manufacturer.

K.2 Test conditions

The system is supplied with the reference test gas(es) corresponding to its category and operated within ± 2 % of the nominal heat input.

The CO₂ concentration and the temperature of the combustion products are measured by means of a suitable probe, incorporating a temperature-measuring device, located in the flue system after the draught diverter or in the combustion products outlet duct, as appropriate. The sampling rate of combustion products for the measurement of temperature is approximately 100 l/h.

The test probe to be used is as shown in Figure K.1 and is positioned at least 800 mm above the flue outlet connection on the system in accordance with the manufacturer's instructions.

K.3 Test procedure

With the system installed and adjusted as described in K.1.3, the system is operated for a sufficient time to reach thermal equilibrium. Measurements are then made of the temperature and the CO₂ concentration of the combustion products and of the combustion air.

The gas rate is measured by timing an integral number of revolutions of the gas meter over a period of at least 100 s.

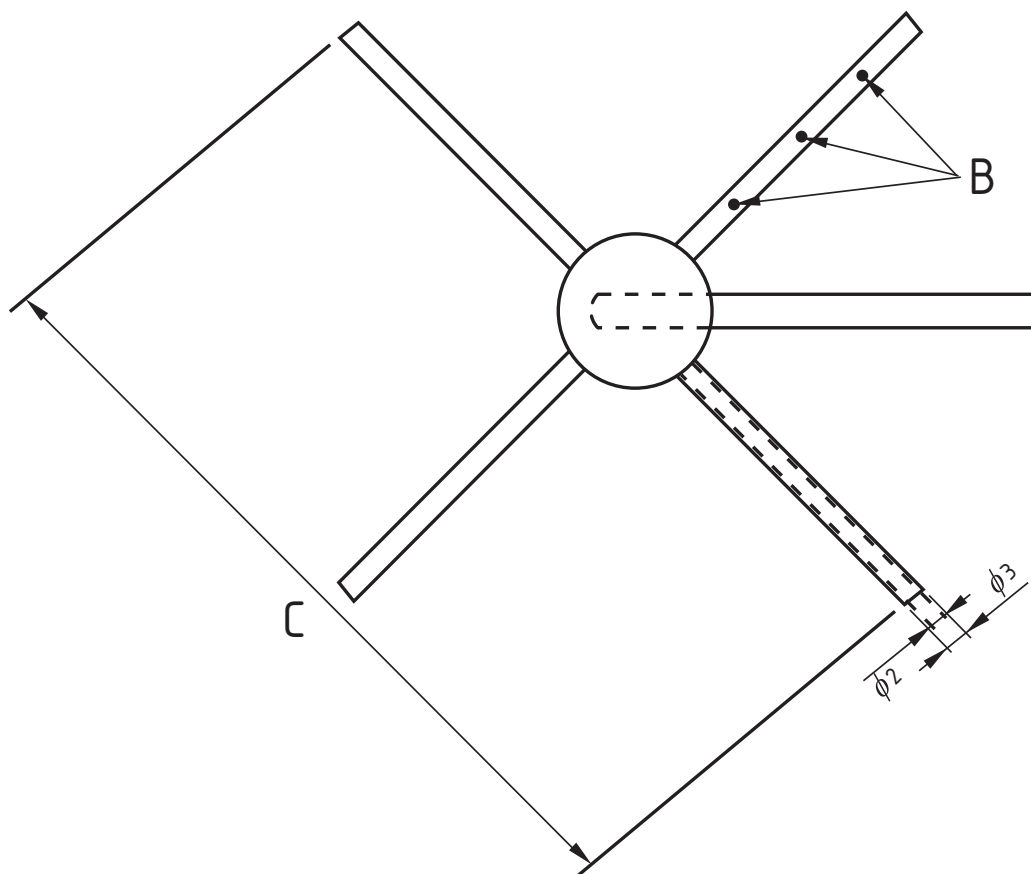
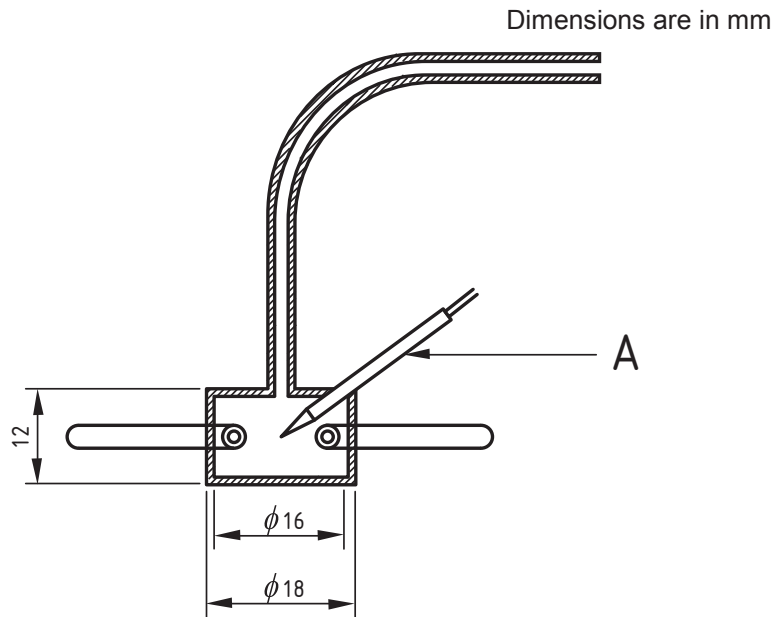

NOTE Sampling probe material is stainless steel with a polished finish.

Key

- A Steatite tube with two holes into which the thermocouple wires are sealed
- B Three equally spaced $\text{Ø } 1$ mm holes in each of three limbs
- C $0,97D$ where D is the internal diameter of the flue

Figure K.1 — Sampling probe

K.4 Accuracy of measurement

Measurements are made to the following accuracy.

Table K.1 — Accuracy of measurement

Quantity measured	Measurement accuracy
Combustion air temperature	$\pm 0,5 \text{ }^{\circ}\text{C}$
Combustion products temperature	$\pm 2 \text{ }^{\circ}\text{C}$
CO ₂ concentration of the combustion air and the combustion products	$\pm 6 \%$ of the sample concentration
Calorific value	$\pm 0,5 \%$

K.5 Calculation of Flue Loss

The symbols used in the determination are defined as follows:

q_1 is the heat of the dry products of combustion (percentage of heat released per unit volume of gas);

q_2 is the heat of the water vapour contained in the products of combustion (percentage of heat released per unit volume of gas);

C_1 is the mean specific heat of the dry products of combustion in MJ/(m³·K) (see Figure K.2);

t_1 is the average combustion air temperature in °C;

t_2 is the average temperature of the products of combustion in °C;

H_i is the net calorific value of the gas at 1 013,25 mbar and 15 °C, dry in MJ/m³;

H_s is the gross calorific value of the gas at 1 013,25 mbar and 15 °C, dry in MJ/m³;

V_f is the volume of dry products of combustion per unit volume of gas in m³.

V_f is calculated from the volume of CO₂ (V_{CO_2}) produced by the combustion of one cubic metre of gas (see Table K.2), and from the CO₂ concentration of the products of combustion ($V_{\text{CO}_2, \text{M}}$).

Table K.2 — V_{CO_2} values

Gas designation	V_{CO_2}
G 110	0,26
G 120	0,32
G 20	1
G 25	0,86
G 30	4
G 31	3

The flue loss, q , (in %) is given by:

$$q_L = q_1 + q_2$$

where:

q_1 is the heat of the dry products of combustion (percentage of heat released per unit volume of gas);

and:

q_2 is the heat of the water vapour contained in the products of combustion (percentage of heat released per unit volume of gas).

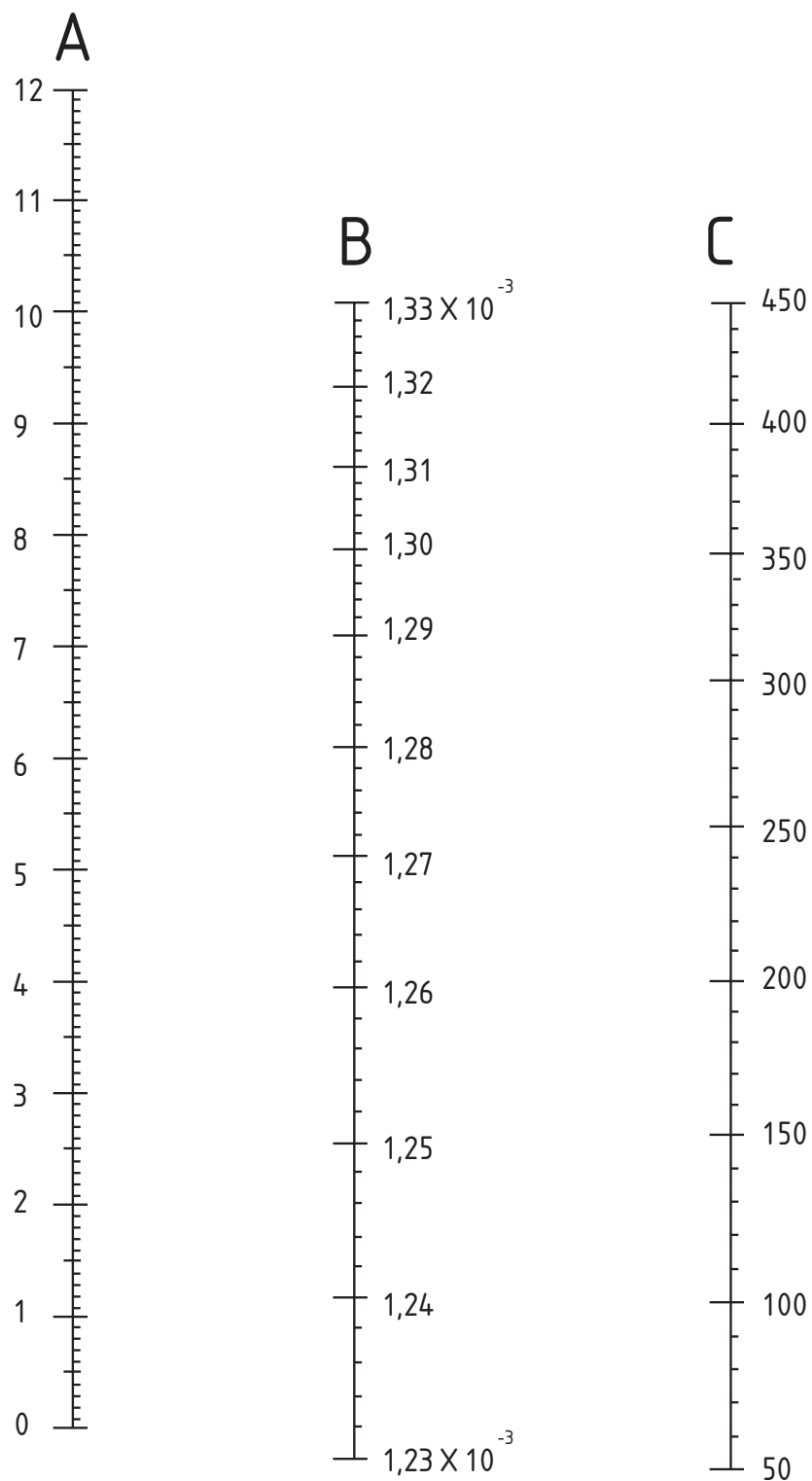

Key

- 1 % CO₂ in combustion products minus % CO₂ in air
- 2 Mean specific heat of dry products of combustion in MJ/m³K
- 3 Temperature of combustion products in °C

Figure K.2 —Mean specific heat of dry products of combustion

Annex ZA (informative)

Clauses of this European Standard addressing essential requirements or other provisions of EU Directives

This European Standard has been prepared under a mandate given to CEN by the European Commission and the European Free Trade Association and supports essential requirements of EU Directive 90/396/EEC "The approximation of the laws of Member States concerning gas appliances".

WARNING: Other requirements and other EU Directives may be applicable to the products falling within the scope of this standard.

The following clauses of this standard are likely to support requirements of Directive 90/396/EEC.

Compliance with these clauses of this standard provides one means of conforming with the specific essential requirements of the Directive concerned and associated EFTA regulations.

Table ZA.1 —

Essential requirement	Subject	Relevant clauses in EN 777-1
1.1	Safe design and construction	Whole standard
1.2	Instructions and warning notices	
1.2.1	Installation instructions Type of gas used Gas supply pressure Fresh air - for combustion - products dispersal Forced draught burners	8.2.2.1 8.1.2 8.1.2, 8.1.4 8.1.3, 8.1.4 8.1.4, 8.2.2.1 Not applicable
1.2.2	Instructions for use and servicing	8.2.1, 8.2.3
1.2.3	Warning notices on system and packaging	8.1.3, 8.1.4
1.3	Fittings Instructions	5.2 Not applicable
2.1	Characteristic of material	5.1.2, 6.7
2.2	Properties of materials	1
3.1.1	Durability	5.1.2
3.1.2	Condensation	6.7f
3.1.3	Explosion risk	5.1.2, 5.1.4.1
3.1.4	Air/water penetration	6.1.1
3.1.5	Normal auxiliary energy fluctuation	5.1.9, 6.6.1 d)
3.1.6	Abnormal auxiliary energy fluctuation	5.1.9, 6.6.1 d)
3.1.7	Electrical hazards	5.1.8
3.1.8	Parts under pressure	Not applicable
3.1.9	Safety/control device failure - automatic burner control systems - multifunctional control - automatic shut-off valves - thermostats/cut-off device - regulators - air proving device	5.2.12.1 5.2.7 5.2.8, 5.2.12.6 5.2.10, 5.2.12.7 5.2.6 5.2.11, 6.6.1e), 6.6.2
3.1.10	Overruling of safety devices	5.2.1
3.1.11	Pre-set adjuster protection	5.2.2
3.1.12	Levers and setting devices	5.2.5.2
3.2.1	Gas leakage	5.1.4, 6.1
3.2.2	Gas release during ignition, extinction, re-ignition	5.2.7, 5.2.8 5.2.12

Table Z.A 1 (concluded)

Essential requirement	Subject	Relevant clauses in EN 777-1
3.2.3	Unburned gas accumulation	5.2.11
3.3	Ignition - ignition, re-ignition - cross-lighting	5.2.12.5, 5.2.12.6, 5.3, 6.4 5.2.12.5, 5.2.12.6 5.3.3, 6.4
3.4.1	Flame stability Harmful substances	6.4 6.6
3.4.2	Combustion products release - normal use	5.1.4.2, 8.2.2.1c
3.4.3	Combustion products release - abnormal draught condition	6.6.2
3.4.4	Flueless domestic systems	Not applicable
3.5	Rational use of energy	Not covered by this standard (see scope)
3.6.1	Floor etc. temperatures	6.3.1
3.6.2	Temperature of knobs/levers	Not applicable (see 5.2.1)
3.6.3	External parts	Not applicable
3.7	Foodstuffs and water	Not applicable

Annex ZB (informative)

Clauses of this European Standard addressing the provisions of the EU Construction Products Directive

ZB.1 Scope and relevant characteristics

This European Standard has been prepared under Mandate M105 “Chimneys, flues and specific products” given to CEN by the European Commission and the European Free Trade Association.

The clauses of this European Standard shown in this annex meet the requirements of the mandate given under the EU Construction Products Directive (89/106/EEC).

Compliance with these clauses confers a presumption of fitness of the chimneys covered by this Annex for the intended uses indicated herein; reference shall be made to the information accompanying the CE marking.

WARNING: Other requirements and other EU Directives, not affecting the fitness for intended uses, can be applicable to the chimneys falling within the scope of this European Standard.

NOTE 1 In addition to any specific clauses relating to dangerous substances contained in this standard, there may be other requirements applicable to the products falling within its scope (e.g. transposed European legislation and national laws, regulations and administrative provisions). In order to meet the provisions of the EU Construction Products Directive, these requirements need also to be complied with, when and where they apply.

NOTE 2 An informative database of European and national provisions on dangerous substances is available at the Construction web site on EUROPA (accessed through <http://europa.eu.int/comm/enterprise/construction/internal/dangsub/dangmain.htm>).

This Annex establishes the conditions for the CE marking of the chimneys intended for the uses indicated in Table ZB.1 and shows the relevant clauses applicable:

This Annex has the same scope as Clause 1 of this standard and is defined by Tables ZB.1 and ZB.2

Table ZB.1 — Scope and relevant requirement clauses

Product: Metal system POCEs as covered in Clause 1 of this standard, except terminals and supports.			
Intended use: Single- and multi-wall POCEs			
Essential Characteristics	Requirement clauses in this European Standard(s)	Levels and/or classes	Notes
Compressive strength	8.2.2.1 f)	None	Manufacturer's declaration
Fire reaction	None	None	Not applicable ^a
Resistance to fire	None	None	Not applicable ^{b c}
Gas tightness /leakage	6.1.2	None	Pass/fail criteria
Flow resistance	8.2.2.1 g)	None	Manufacturer's declaration of minimum and maximum equivalent resistance
Thermal resistance/ Dimensioning	None 8.2.2.1	None None	Not applicable ^d Manufacturer's declaration
Thermal shock resistance	None	None	Not applicable ^b
Flexural tensile strength	5.1.5 8.2.2.1	None	Pass/ fail criteria. Manufacturer's declared value
Durability against chemicals	5.1.2 6.7	None	Pass-fail criteria
Durability against corrosion	5.1.2 6.7	None	Pass-fail criteria
Resistance to Freeze - thaw	None	None	Not applicable ^e

^a Fire reaction- No requirements for metal POCEs.
^b Soot fire resistance G - is not applicable to gas-fired appliances.
^c Insulation I - is not required for metal POCEs.
Integrity E - is not required for metal POCEs.
^d This characteristic is only relevant when it is required to match the chimney with the appliance.
The Performance of the POCE is verified as part of the performance testing of the appliance.
^e This characteristic is only relevant to construction materials that absorb water. This standard only applies to appliances with metal POCEs.

Table ZB.2 — Scope and relevant requirement clauses

Product: Terminals as covered in Clause 1 of this standard			
Intended use: Single- and multi-wall POCEDs			
Essential Characteristics	Requirement clauses in this European Standard(s)	Levels and/or classes	Notes
Flow resistance	8.2.2.1 g)	None	Manufacturer's declaration.

The requirement on a certain characteristic is not applicable in those Member States (MSs) where there are no regulatory requirements on that characteristic for the intended use of the product. In this case, manufacturers placing their products on the market of these MSs are not obliged to determine nor declare the performance of their products with regard to this characteristic and the option "No performance determined" (NPD) in the information accompanying the CE marking (see ZB.3) may be used. The NPD option may not be used, however, where the characteristic is subject to a threshold level.

ZB.2 Procedure(s) for attestation of conformity of [construction products]

ZB.2.1 System(s) of attestation of conformity

The system(s) of attestation of conformity of the POCEDs indicated in Tables ZB.1 and ZB.2 in accordance with the Decision of the Commission 95/467/EC of 27-09-95 as given in Annex III of the mandate for "Chimneys, flues and specific products", is shown in Table ZB.3 for the indicated intended use(s) and relevant level(s) or class(es).

Table ZB.3 — System(s) of attestation of conformity

Product(s)	Intended use(s)	Level(s) class(es)	or	Attestation of conformity system(s)
Metal system chimney products	Chimneys	Any		2+
Terminals				4
<p>System 2+: See Directive 89/106/EEC (CPD) Annex III.2.(ii), First possibility, including certification of the factory production control by an approved body on the basis of initial inspection of factory and of factory production control as well as of continuous surveillance, assessment and approval of factory production control.</p> <p>System 4: See Directive 89/106/EEC (CPD) Annex III.2.(ii), Third possibility.</p>				

The attestation of conformity of the POCEDs in Tables ZB.1 and ZB.1.2 shall be based on the evaluation of conformity procedures indicated in Tables ZB.4 and ZB.5 respectively resulting from application of the clauses of this or other European standard indicated therein.

Table ZB.4 — Assignment of evaluation of conformity tasks for chimneys under system 2+ in Table ZB.1

Tasks		Content of the task	Evaluation of conformity clauses to apply
Tasks under the responsibility of the manufacturer	Factory production control (FPC)	Parameters related to all relevant characteristics of Table ZB.1	9.3
	Initial type testing by the manufacturer	All relevant characteristics of Table ZB.1	9.2
	Possibly testing of samples taken at the factory	All relevant characteristics of Table ZB.1	9.3
Tasks of the Approved body	Certification of the FPC by the FPC certification body on the basis of :-	Initial inspection of factory and of FPC	9.3
		Continuous surveillance, assessment and approval of FPC	9.3

Table ZB.5 — Assignment of evaluation of conformity tasks for terminals in Table ZB.2

Tasks		Content of the task	Evaluation of conformity clauses to apply
Tasks for the manufacturer	Factory production control (F.P.C)	Parameters related to all relevant characteristics of Table ZB.2	9.3
	Initial type testing	All relevant characteristics of Table ZB.2	9.2

ZB.2.2 EC Certificate and Declaration of conformity

When, in the case of products under system of conformity 2+, compliance with the conditions of this Annex is achieved, and once the notified body has drawn up the certificate mentioned below, the manufacturer or his agent established in the EEA shall prepare and retain a declaration of conformity, which entitles the manufacturer to affix the CE marking. This declaration shall include:

- name and address of the manufacturer, or his authorised representative established in the EEA, and the place of production;

NOTE 1 The manufacturer may also be the person responsible for placing the product onto the EEA market, if he takes responsibility for CE marking.

- description of the product (type, identification, use, etc.), and a copy of the information accompanying the CE marking;

NOTE 2 Where some information required for the declaration is already given in the CE marking information, it does not need to be repeated.

- provisions to which the product conforms (i.e. Annex ZB of this EN);
- particular conditions applicable to the use of the product (e.g. provisions for use under certain conditions);
- the number of the accompanying factory production control certificate;
- name of, and position held by, the person empowered to sign the declaration on behalf of the manufacturer or his authorised representative.

The declaration shall be accompanied by a factory production control certificate, drawn up by the notified body, which shall contain, in addition to the information above, the following:

- name and address of the notified body;
- the number of the factory production control certificate;
- conditions and period of validity of the certificate, where applicable;
- name of, and position held by, the person empowered to sign the certificate.

The above mentioned declaration and certificate shall be presented in the official language or languages of the Member State in which the product is to be used.

When, in the case of products under system of conformity 4, compliance with the conditions of this Annex is achieved, the manufacturer or his agent established in the EEA shall prepare and retain a declaration of conformity (EC Declaration of conformity), which entitles the manufacturer to affix the CE marking. This declaration shall include:

- name and address of the manufacturer, or his authorised representative established in the EEA, and the place of production;

NOTE 3 The manufacturer may also be the person responsible for placing the product onto the EEA market, if he takes responsibility for CE marking.

- description of the product (type, identification, use, etc.), and a copy of the information accompanying the CE marking;

NOTE 4 Where some information required for the declaration is already given in the CE marking information, it does not need to be repeated.

- provisions to which the product conforms (i.e. Annex ZB of this EN), and a reference to the ITT report(s) and factory production control records (if appropriate);
- particular conditions applicable to the use of the product (e.g. provisions for use under certain conditions);
- name of, and position held by, the person empowered to sign the declaration on behalf of the manufacturer or his authorised representative.

ZB.3 CE marking and labelling

The manufacturer or his authorised representative established within the EEA is responsible for the affixing of the CE marking.

The CE marking symbol to affix shall be in accordance with Directive 93/68/EC and shall be shown on the appliance Data Badge. The following information shall accompany the CE marking symbol and may be on the Data Badge, the packaging, in the appliance Installation instructions or as a separate insert with the appliance instruction pack. Where it is not possible for this information to appear with the CE marking symbol on the appliance Data Badge, the CE marking symbol will be repeated at the head of the information, see Figure ZB.1:

- identification number of the certification body (only for products under systems 2+);

NOTE The certification body is the “Notified Body” (notified under the CPD) responsible for the Factory Production Control Certificate (FPC certificate).

- name or identifying mark and registered address of the appliance manufacturer;
- the last two digits of the year in which the marking is affixed;
- number of the factory production control certificate (if relevant);
- reference to this European Standard;

Figure ZB.1 gives an example of the information to be given on the product, label, packaging and/or commercial documents.

 01234
AnyCo Ltd, PO Box 21, B-1050 05 01234-CPD-00234
EN 777-1:2009 Metal POCED

CE conformity marking, consisting of the “CE”-symbol given in directive 93/68/EEC.

Identification number of the notified body

Name or identifying mark and registered address of the manufacturer

Last two digits of the year in which the marking was affixed

Certificate number

Number of European standard

Definition of the product

Information on mandated characteristics not included in the designation or threshold values to be given (see Table ZB.1)

In addition to any specific information relating to dangerous substances shown above, the product should also be accompanied, when and where required and in the appropriate form, by documentation listing any other legislation on dangerous substances for which compliance is claimed, together with any information required by that legislation.

NOTE 1 European legislation without national derogations need not be mentioned.

NOTE 2 Affixing the CE marking symbol to a product means that it complies with all applicable directives.

Figure ZB.1 — Example of CE marking information of a POCED

Bibliography

- [1] EN 416-1, *Single burner gas-fired overhead radiant tube heaters for non-domestic use - Part 1: Safety*
- [2] EN 125:1991, *Flame supervision devices for gas burning appliances - Thermo-electric flame supervision devices*
- [3] EN 60730-1:2001, *Automatic electrical controls for household and similar use - Part 1: General requirements*
- [4] EN 60730-2-1:1997, *Automatic electrical controls for household and similar use - Part 2-1: Particular requirements for electrical controls for electrical household appliances*
- [5] EN 60730-2-9:2002, *Automatic electrical controls for household and similar use - Part 2-9: Particular requirements for temperature sensing controls*
- [6] CEN/TR 1749:2005, *European scheme for the classification of gas appliances according to the method of evacuation of the combustion products (types)*
- [7] ISO 274:1975, *Copper tubes of circular section — Dimensions*

BSI - British Standards Institution

BSI is the independent national body responsible for preparing British Standards. It presents the UK view on standards in Europe and at the international level. It is incorporated by Royal Charter.

Revisions

British Standards are updated by amendment or revision. Users of British Standards should make sure that they possess the latest amendments or editions.

It is the constant aim of BSI to improve the quality of our products and services. We would be grateful if anyone finding an inaccuracy or ambiguity while using this British Standard would inform the Secretary of the technical committee responsible, the identity of which can be found on the inside front cover. Tel: +44 (0)20 8996 9000. Fax: +44 (0)20 8996 7400.

BSI offers members an individual updating service called PLUS which ensures that subscribers automatically receive the latest editions of standards.

Buying standards

Orders for all BSI, international and foreign standards publications should be addressed to Customer Services. Tel: +44 (0)20 8996 9001. Fax: +44 (0)20 8996 7001 Email: orders@bsigroup.com You may also buy directly using a debit/credit card from the BSI Shop on the Website <http://www.bsigroup.com/shop>

In response to orders for international standards, it is BSI policy to supply the BSI implementation of those that have been published as British Standards, unless otherwise requested.

Information on standards

BSI provides a wide range of information on national, European and international standards through its Library and its Technical Help to Exporters Service. Various BSI electronic information services are also available which give details on all its products and services. Contact Information Centre. Tel: +44 (0)20 8996 7111 Fax: +44 (0)20 8996 7048 Email: info@bsigroup.com

Subscribing members of BSI are kept up to date with standards developments and receive substantial discounts on the purchase price of standards. For details of these and other benefits contact Membership Administration. Tel: +44 (0)20 8996 7002 Fax: +44 (0)20 8996 7001 Email: membership@bsigroup.com

Information regarding online access to British Standards via British Standards Online can be found at <http://www.bsigroup.com/BSOL>

Further information about BSI is available on the BSI website at <http://www.bsigroup.com>.

Copyright

Copyright subsists in all BSI publications. BSI also holds the copyright, in the UK, of the publications of the international standardization bodies. Except as permitted under the Copyright, Designs and Patents Act 1988 no extract may be reproduced, stored in a retrieval system or transmitted in any form or by any means – electronic, photocopying, recording or otherwise – without prior written permission from BSI.

This does not preclude the free use, in the course of implementing the standard, of necessary details such as symbols, and size, type or grade designations. If these details are to be used for any other purpose than implementation then the prior written permission of BSI must be obtained.

Details and advice can be obtained from the Copyright and Licensing Manager. Tel: +44 (0)20 8996 7070 Email: copyright@bsigroup.com