

Leisure accommodation vehicles — Liquid fuel heating systems —

Part 1: Caravans and caravan holiday homes

The European Standard EN 722-1:2004 has the status of a
British Standard

ICS 43.100

National foreword

This British Standard is the official English language version of EN 722-1:2004. It supersedes BS EN 722-1:1996 which is withdrawn.

The UK participation in its preparation was entrusted to Technical Committee B/511, Buildings, mobile and temporary, which has the responsibility to:

- aid enquirers to understand the text;
- present to the responsible international/European committee any enquiries on the interpretation, or proposals for change, and keep the UK interests informed;
- monitor related international and European developments and promulgate them in the UK.

A list of organizations represented on this committee can be obtained on request to its secretary.

Cross-references

The British Standards which implement international or European publications referred to in this document may be found in the *BSI Catalogue* under the section entitled “International Standards Correspondence Index”, or by using the “Search” facility of the *BSI Electronic Catalogue* or of British Standards Online.

This publication does not purport to include all the necessary provisions of a contract. Users are responsible for its correct application.

Compliance with a British Standard does not of itself confer immunity from legal obligations.

Summary of pages

This document comprises a front cover, an inside front cover, the EN title page, pages 2 to 9 and a back cover.

The BSI copyright notice displayed in this document indicates when the document was last issued.

This British Standard was published under the authority of the Standards Policy and Strategy Committee on 23 June 2005

© BSI 23 June 2005

ISBN 0 580 46161 0

Amendments issued since publication

Amd. No.	Date	Comments

English version

Leisure accommodation vehicles - Liquid fuel heating systems - Part 1: Caravans and caravan holiday homes

Véhicules habitables de loisirs - Systèmes de chauffage à combustibles liquides - Partie 1 : Caravanes et résidences mobiles

Bewohnbare Freizeitfahrzeuge - Mit flüssigem Brennstoff betriebene Heizungssysteme - Teil 1: Caravans und Mobilheime

This European Standard was approved by CEN on 9 July 2004.

CEN members are bound to comply with the CEN/CENELEC Internal Regulations which stipulate the conditions for giving this European Standard the status of a national standard without any alteration. Up-to-date lists and bibliographical references concerning such national standards may be obtained on application to the Central Secretariat or to any CEN member.

This European Standard exists in three official versions (English, French, German). A version in any other language made by translation under the responsibility of a CEN member into its own language and notified to the Central Secretariat has the same status as the official versions.

CEN members are the national standards bodies of Austria, Belgium, Cyprus, Czech Republic, Denmark, Estonia, Finland, France, Germany, Greece, Hungary, Iceland, Ireland, Italy, Latvia, Lithuania, Luxembourg, Malta, Netherlands, Norway, Poland, Portugal, Slovakia, Slovenia, Spain, Sweden, Switzerland and United Kingdom.



EUROPEAN COMMITTEE FOR STANDARDIZATION
COMITÉ EUROPÉEN DE NORMALISATION
EUROPÄISCHES KOMITEE FÜR NORMUNG

Management Centre: rue de Stassart, 36 B-1050 Brussels

Contents

	Page
Foreword	3
1 Scope	4
2 Normative references	4
3 Terms and definitions	4
4 Requirements	4
4.1 General	4
4.2 Oil tanks	4
4.2.1 Location	4
4.2.2 Stopcock	4
4.2.3 Capacity	4
4.2.4 Spillage	5
4.3 Heating appliances	5
4.3.1 Types and installation	5
4.3.2 Products of combustion	5
4.3.3 Accessibility	7
4.4 Fuel pipes	7
4.4.1 General	7
4.4.2 Materials	7
4.4.3 Corrosion protection	7
4.4.4 Joints	7
4.4.5 Mechanical protection	7
4.5 Flues	7
4.5.1 Flue pipes	7
4.5.2 Weather protection	7
4.5.3 Draught diverters and dampers for caravan holiday homes	7
4.5.4 Accessibility	8
4.6 Fire valve	8
5 User's handbook	8
Bibliography	9

Foreword

This document (EN 722-1:2004) has been prepared by Technical Committee CEN/TC 245 "*Leisure accommodation vehicles*", the secretariat of which is held by BSI.

This European Standard shall be given the status of a national standard, either by publication of an identical text or by endorsement, at the latest by March 2005, and conflicting national standards shall be withdrawn at the latest by March 2005.

This document supersedes EN 722-1:1996.

According to the CEN/CENELEC Internal Regulations, the national standards organizations of the following countries are bound to implement this European Standard: Austria, Belgium, Cyprus, Czech Republic, Denmark, Estonia, Finland, France, Germany, Greece, Hungary, Iceland, Ireland, Italy, Latvia, Lithuania, Luxembourg, Malta, Netherlands, Norway, Poland, Portugal, Slovakia, Slovenia, Spain, Sweden, Switzerland and United Kingdom.

1 Scope

This document specifies safety requirements for installing oil-fired heating systems in caravans and caravan holiday homes. It applies to liquid fuel heating systems using oil fuels as defined in EN 13878.

NOTE Safety ventilation requirements for leisure accommodation vehicles are specified in EN 721.

2 Normative references

The following referenced documents are indispensable for the application of this document. For dated references, only the edition cited applies. For undated references, the latest edition of the referenced document (including any amendments) applies.

EN 13878:2003, *Leisure accommodation vehicles — Terms and definitions*

3 Terms and definitions

For the purposes of this document, the terms and definitions given in EN 13878:2003 apply.

4 Requirements

4.1 General

The installation of liquid fuel heating systems shall be carried out in accordance with the instructions of the manufacturers of the equipment and appliances.

The system shall not leak when installed and shall be operated in accordance with the instructions of the manufacturer.

The components of the system shall be of material suitable for use with liquid fuels.

4.2 Oil tanks

4.2.1 Location

Oil tanks shall be located so as to permit filling and draining from outside and if separate from the heating appliance shall be placed in a fuel storage compartment or fuel storage housing. This compartment or housing shall be ventilated to the outside of the leisure accommodation vehicle and an opening shall be provided at the bottom to permit the drainage of water to the outside of the leisure accommodation vehicle.

4.2.2 Stopcock

A stopcock shall be provided at the outlet of each tank. It shall be readily accessible.

4.2.3 Capacity

The capacity of the tank for the installation shall not exceed 50 l for caravans and 200 l for caravan holiday homes.

4.2.4 Spillage

Provision shall be made to ensure that, in the event of spillage when filling the tank, fuel shall not be dispersed inside or below the leisure accommodation vehicle, whether the tank is integral with an appliance or not.

4.3 Heating appliances

4.3.1 Types and installation

For caravans, only room-sealed appliances shall be used.

For caravan holiday homes, heating appliances which draw their combustion air from inside the leisure accommodation vehicle, are permitted.

All heating appliances shall be securely fixed. Provision shall be made to protect any combustible material adjacent to any heat-generating appliance in accordance with the heating appliance manufacturer's instructions.

4.3.2 Products of combustion

All heating appliances shall be installed in such a way that the products of combustion shall be ducted to the outside of the leisure accommodation vehicle. Combustion products shall not be evacuated under the leisure accommodation vehicle.

Flue terminals shall be sited in accordance with the heating appliance manufacturer's instructions, preferably on the roof or in the wall of the vehicle.

NOTE It is recommended that flue terminals be positioned so that wind turbulence will not affect proper operation.

Flue terminals shall not be positioned within 500 mm of a refuelling point of fuel tank breather outlet or any ventilator from a liquid fuel system(s).

Flue terminals positioned on a wall or a roof for heating appliances shall not be fitted within 300 mm of a ventilator for the habitation area (see Figure 1) or an opening part of a window (see Figure 2).

Where the flue terminal of a heating appliance is positioned vertically below an opening part of a window, the heating appliance shall be fitted with an automatic shut-off device to prevent operation when the window is open.

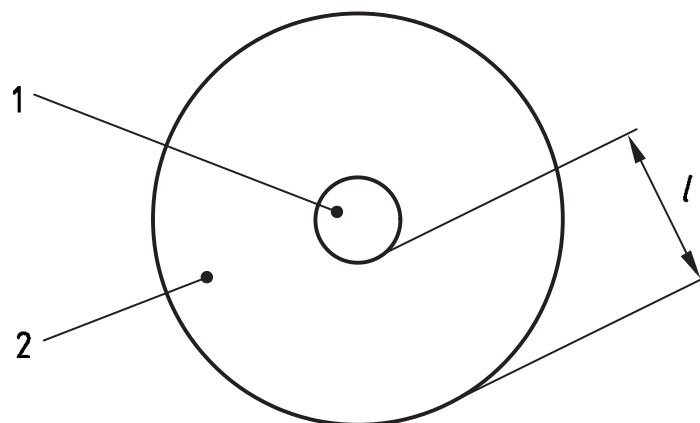

Key

- 1 Ventilator
- 2 Prohibited zone
- $l = 300 \text{ mm}$

Figure 1 — Prohibited zone for discharge openings for the products of combustion in relation to ventilators

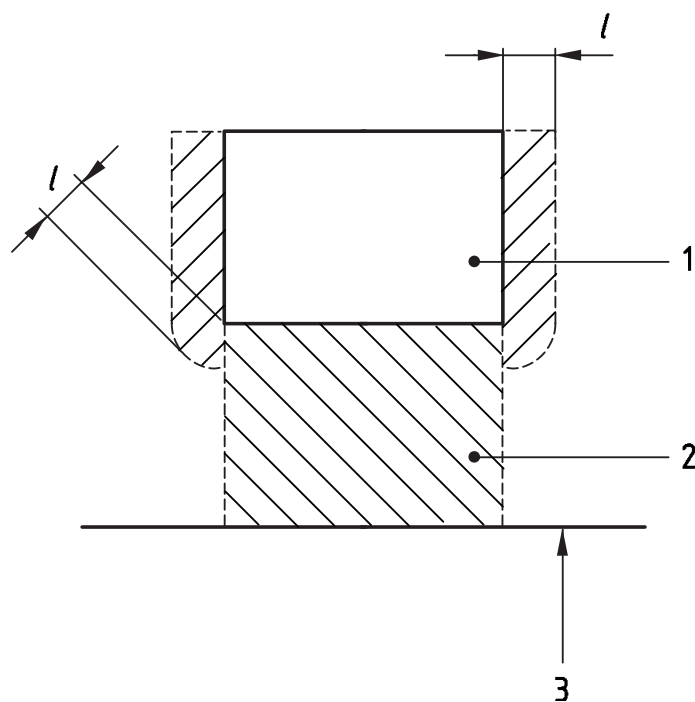

Key

- 1 Window
- 2 Prohibited zone
- 3 Floor
- $l = 300 \text{ mm}$

Figure 2 — Prohibited zone for discharge openings for the products of combustion in relation to windows

4.3.3 Accessibility

Every appliance shall be accessible for inspection, service, repair or replacement.

4.4 Fuel pipes

4.4.1 General

The bore of piping shall not be significantly restricted either through bending or cutting. There shall be no contact between the piping and electrical cables.

4.4.2 Materials

Pipework shall be of seam-welded steel or of seamless steel, stainless steel or copper or any materials recommended by the appliance manufacturer.

4.4.3 Corrosion protection

Pipes which are in contact with material likely to cause corrosion, shall be protected throughout the area of contact. In places exposed to corrosion, especially underneath the vehicle and in ducts, pipes shall be protected by anti-corrosion measures, e.g. plastic coating or bituminous paintwork, or be of corrosion resistant material.

4.4.4 Joints

Connections shall be made by flat-faced washered joints or compression joints. Soft soldered joints shall not be used. Joints shall be accessible and secured so that they are not affected by vibration.

4.4.5 Mechanical protection

Pipework shall be protected against mechanical damage, either by its location or by grommets or other means, where necessary.

4.5 Flues

4.5.1 Flue pipes

Flue pipes shall be sealed to prevent the products of combustion entering the leisure accommodation vehicle and shall be constructed of non-combustible material, which shall be compatible with the characteristics of the appliance and the manufacturer's installation instructions. Flue pipes shall remain firmly in position particularly in the case of leisure accommodation vehicles in motion.

4.5.2 Weather protection

Where a flue pipe passes through a wall or roof, measures shall be taken to prevent ingress of water. The flue terminal shall be fitted with a weather cap, so designed as not to obstruct the emission of flue gases.

4.5.3 Draught diverters and dampers for caravan holiday homes

When a draught diverter is fitted, it shall be integral with a heating appliance or immediately adjacent to it. No additional draught diverter or damper that restricts the area of a flue shall be fitted.

4.5.4 Accessibility

Means shall be provided to allow periodic inspection of the whole of the circumference and length of uninsulated flue pipes, the flue ends and attachments and the whole of the outside of the insulating sleeve of insulated flue pipes. Panels or structure shall be removable by means of a simple tool such as a screwdriver. It shall be permissible to carry out an inspection by the use of a hand-held mirror or by feel as an acceptable alternative to direct visual inspection.

4.6 Fire valve

A thermally operated fire valve shall be fitted as an integral part of the installation to shut off the fuel supply should overheating occur.

5 User's handbook

The leisure accommodation vehicle's manufacturer shall provide instructions for the correct operation and maintenance of the system, which shall be provided as part of the User's handbook, worded at least in the language of the country where the leisure accommodation vehicle is first sold. These instructions shall clearly state the specification of fuel for which the system has been designed and, where applicable, whether the system is suitable for use while the caravan is in motion.

Bibliography

- [1] EN 721, *Leisure accommodation vehicles — Safety ventilation requirements*

BSI — British Standards Institution

BSI is the independent national body responsible for preparing British Standards. It presents the UK view on standards in Europe and at the international level. It is incorporated by Royal Charter.

Revisions

British Standards are updated by amendment or revision. Users of British Standards should make sure that they possess the latest amendments or editions.

It is the constant aim of BSI to improve the quality of our products and services. We would be grateful if anyone finding an inaccuracy or ambiguity while using this British Standard would inform the Secretary of the technical committee responsible, the identity of which can be found on the inside front cover.
Tel: +44 (0)20 8996 9000. Fax: +44 (0)20 8996 7400.

BSI offers members an individual updating service called PLUS which ensures that subscribers automatically receive the latest editions of standards.

Buying standards

Orders for all BSI, international and foreign standards publications should be addressed to Customer Services. Tel: +44 (0)20 8996 9001.
Fax: +44 (0)20 8996 7001. Email: orders@bsi-global.com. Standards are also available from the BSI website at <http://www.bsi-global.com>.

In response to orders for international standards, it is BSI policy to supply the BSI implementation of those that have been published as British Standards, unless otherwise requested.

Information on standards

BSI provides a wide range of information on national, European and international standards through its Library and its Technical Help to Exporters Service. Various BSI electronic information services are also available which give details on all its products and services. Contact the Information Centre.
Tel: +44 (0)20 8996 7111. Fax: +44 (0)20 8996 7048. Email: info@bsi-global.com.

Subscribing members of BSI are kept up to date with standards developments and receive substantial discounts on the purchase price of standards. For details of these and other benefits contact Membership Administration.
Tel: +44 (0)20 8996 7002. Fax: +44 (0)20 8996 7001.
Email: membership@bsi-global.com.

Information regarding online access to British Standards via British Standards Online can be found at <http://www.bsi-global.com/bsonline>.

Further information about BSI is available on the BSI website at <http://www.bsi-global.com>.

Copyright

Copyright subsists in all BSI publications. BSI also holds the copyright, in the UK, of the publications of the international standardization bodies. Except as permitted under the Copyright, Designs and Patents Act 1988 no extract may be reproduced, stored in a retrieval system or transmitted in any form or by any means – electronic, photocopying, recording or otherwise – without prior written permission from BSI.

This does not preclude the free use, in the course of implementing the standard, of necessary details such as symbols, and size, type or grade designations. If these details are to be used for any other purpose than implementation then the prior written permission of BSI must be obtained.

Details and advice can be obtained from the Copyright & Licensing Manager.
Tel: +44 (0)20 8996 7070. Fax: +44 (0)20 8996 7553.
Email: copyright@bsi-global.com.