

**BS EN 690:2013**



**BSI Standards Publication**

# **Agricultural machinery — Manure spreaders — Safety**

**bsi.**

...making excellence a habit.™

### National foreword

This British Standard is the UK implementation of EN 690:2013. It supersedes BS EN 690:1994+A1:2009 which is withdrawn.

BSI, as a member of CEN, is obliged to publish EN 690 as a British Standard. However, attention is drawn to the fact that during the development of this European Standard, the UK committee voted against its approval as a European Standard. In the opinion of the UK committee, clause 5.3.2 is not applicable to machinery currently in use and it requires further review. It is subject to amendment by CEN/TC 144/WG 3, together with other technical issues.

The UK participation in its preparation was entrusted to Technical Committee AGE/32, Agricultural implements and trailers.

A list of organizations represented on this committee can be obtained on request to its secretary.

This publication does not purport to include all the necessary provisions of a contract. Users are responsible for its correct application.

© The British Standards Institution 2014. Published by BSI Standards Limited 2014

ISBN 978 0 580 77023 4

ICS 65.060.25

**Compliance with a British Standard cannot confer immunity from legal obligations.**

This British Standard was published under the authority of the Standards Policy and Strategy Committee on 31 May 2014.

### Amendments/corrigenda issued since publication

Date	Text affected
------	---------------

---

ICS 65.060.25

English Version

**Agricultural machinery - Manure spreaders - Safety**

Matériel agricole - Epandeurs de fumier - Sécurité

Landmaschinen - Stallungstreuer - Sicherheit

This European Standard was approved by CEN on 14 September 2013.

CEN members are bound to comply with the CEN/CENELEC Internal Regulations which stipulate the conditions for giving this European Standard the status of a national standard without any alteration. Up-to-date lists and bibliographical references concerning such national standards may be obtained on application to the CEN-CENELEC Management Centre or to any CEN member.

This European Standard exists in three official versions (English, French, German). A version in any other language made by translation under the responsibility of a CEN member into its own language and notified to the CEN-CENELEC Management Centre has the same status as the official versions.

CEN members are the national standards bodies of Austria, Belgium, Bulgaria, Croatia, Cyprus, Czech Republic, Denmark, Estonia, Finland, Former Yugoslav Republic of Macedonia, France, Germany, Greece, Hungary, Iceland, Ireland, Italy, Latvia, Lithuania, Luxembourg, Malta, Netherlands, Norway, Poland, Portugal, Romania, Slovakia, Slovenia, Spain, Sweden, Switzerland, Turkey and United Kingdom.

EUROPEAN COMMITTEE FOR STANDARDIZATION  
COMITÉ EUROPÉEN DE NORMALISATION  
EUROPÄISCHES KOMITEE FÜR NORMUNG**CEN-CENELEC Management Centre: Avenue Marnix 17, B-1000 Brussels**

## Contents

Page

Foreword.....	3
Introduction .....	4
1 Scope .....	5
2 Normative references .....	5
3 Terms and definitions .....	6
4 List of significant hazards .....	7
5 Safety requirements and/or protective measures .....	12
5.1 General.....	12
5.2 Location of the manual controls .....	13
5.3 Prevention of unintentional contact with the moving spreading device .....	13
5.3.1 Self-propelled machines .....	13
5.3.2 Mounted, semi-mounted and trailed machines .....	13
5.4 Protection against projectiles .....	13
5.5 Conveyor .....	14
5.5.1 Guarding .....	14
5.5.2 Adjustment of conveyor.....	19
5.6 Means of access .....	20
5.7 Removal of the spreading device.....	20
5.8 Transmission shafts.....	20
5.9 Cleaning .....	20
5.10 Special tools.....	20
5.11 Noise .....	20
5.11.1 Noise reduction by design.....	20
5.11.2 Noise reduction by information.....	21
5.11.3 Noise emission values .....	21
6 Verification of safety requirements or protective measures.....	21
7 Information for use .....	22
7.1 Operator's manual .....	22
7.2 Safety and instructional signs.....	24
7.3 Marking .....	25
Annex A (informative) Illustrations of manure spreaders .....	26
A.1 Examples of manure spreaders with rear spreading device dealt with in present EN 690.....	26
A.2 Examples of manure spreaders with lateral spreading – not dealt with in present EN 690 .....	29
Annex ZA (informative) Relationship between this European Standard and the Essential Requirements of EU Directive 2006/42/EC on machinery .....	30
Bibliography .....	31

## Foreword

This document (EN 690:2013) has been prepared by Technical Committee CEN/TC 144 "Tractors and machinery for agriculture and forestry", the secretariat of which is held by AFNOR.

This European Standard shall be given the status of a national standard, either by publication of an identical text or by endorsement, at the latest by April 2014, and conflicting national standards shall be withdrawn at the latest by April 2014.

Attention is drawn to the possibility that some of the elements of this document may be the subject of patent rights. CEN [and/or CENELEC] shall not be held responsible for identifying any or all such patent rights.

This document supersedes EN 690:1994+A1:2009.

This document has been prepared under a mandate given to CEN by the European Commission and the European Free Trade Association, and supports essential requirements of EU Directive(s).

For relationship with EU Directive(s), see informative Annex ZA, which is an integral part of this document.

The following main changes have been introduced during the revision of EN 690:1994+A1:2009:

- Scope: inclusion of self-propelled, mounted, semi-mounted and trailed manure spreaders, except spreaders with lateral spreading;
- update of Normative References;
- new requirements on prevention of unintentional contacts with moving spreading device;
- new requirements regarding design for cleaning and maintenance operations;
- new requirements regarding design and guarding of conveyor;
- means of access;
- noise.

According to the CEN-CENELEC Internal Regulations, the national standards organizations of the following countries are bound to implement this European Standard: Austria, Belgium, Bulgaria, Croatia, Cyprus, Czech Republic, Denmark, Estonia, Finland, Former Yugoslav Republic of Macedonia, France, Germany, Greece, Hungary, Iceland, Ireland, Italy, Latvia, Lithuania, Luxembourg, Malta, Netherlands, Norway, Poland, Portugal, Romania, Slovakia, Slovenia, Spain, Sweden, Switzerland, Turkey and the United Kingdom.

## **Introduction**

This document is a type-C standard as specified in EN ISO 12100.

The machinery concerned and the extent to which hazards, hazardous situations and hazardous events are covered are indicated in the Scope of this document. These hazards are specific to manure spreaders.

Significant hazards that are common to all the agricultural machines (self-propelled, mounted, semi-mounted and trailed) are dealt with in EN ISO 4254-1. When provisions of this type C standard are different from those which are stated in type A or B standards, the provisions of this type C standard take precedence over the provisions of the other standards, for machines that have been designed and built according to the provisions of this type C standard.

## 1 Scope

This European Standard, to be used together with EN ISO 4254-1, specifies the safety requirements and their verification for the design and construction of self-propelled, mounted, semi-mounted and trailed manure spreaders, provided with vertical or horizontal axes rotors rear spreader device or with vertical axes disc rear spreader device. In addition, it specifies the type of information on safe working practices to be provided by the manufacturer.

When requirements of this document are different from those which are stated in EN ISO 4254-1, the requirements of this document take precedence over the requirements of EN ISO 4254-1 for machines that have been designed and built according the provisions of this document.

This European Standard, taken together with EN ISO 4254-1, deals with all the significant hazards, hazardous situations and events relevant to manure spreaders, when they are used as intended and under the conditions of misuse which are reasonably foreseeable by the manufacturer (see Table 1), excepting the hazards arising from:

- vibrations of self-propelled machinery;
- travelling function of self-propelled machinery;
- overturning in regard to the protection of the operator at the driving station of a self-propelled machine;
- hazards related to conveying devices other than those defined in 3.3.1 and 3.3.2, for example load push/push-off device.

NOTE 1 Regarding roll-over protection for self-propelled agricultural machinery, see EN ISO 16231-1.

NOTE 2 This European Standard is neither applicable to environmental hazards nor to road safety. Environmental aspects are dealt with in EN 13080.

This European Standard does not apply to manure spreaders with laterally mounted spreading device as defined in 3.6.

This European Standard is not applicable to manure spreaders which are manufactured before the date of publication of this document by CEN.

## 2 Normative references

The following documents, in whole or in part, are normatively referenced in this document and are indispensable for its application. For dated references, only the edition cited applies. For undated references, the latest edition of the referenced document (including any amendments) applies.

EN 15811, *Agricultural machinery — Guards for moving parts of power transmission — Guard opening with tool (ISO/TS 28923)*

EN ISO 4254-1:2009, *Agricultural machinery — Safety — Part 1: General requirements (ISO 4254-1:2008)*

EN ISO 5353:1998, *Earth-moving machinery, and tractors and machinery for agriculture and forestry — Seat index point (ISO 5353:1995)*

EN ISO 11688-1, *Acoustics — Recommended practice for the design of low-noise machinery and equipment — Part 1: Planning (ISO/TR 11688-1)*

EN ISO 12100:2010, *Safety of machinery — General principles for design — Risk assessment and risk reduction (ISO 12100:2010)*

EN ISO 13857:2008, *Safety of machinery — Safety distances to prevent hazard zones being reached by upper and lower limbs (ISO 13857:2008)*

EN ISO 14982, *Agricultural and forestry machinery — Electromagnetic compatibility — Test methods and acceptance criteria (ISO 14982)*

ISO 3600, *Tractors, machinery for agriculture and forestry, powered lawn and garden equipment — Operator's manuals — Content and presentation*

### **3 Terms and definitions**

For the purposes of this document, the terms and definitions given in EN ISO 12100:2010 and the following apply.

**3.1 manure spreader**  
machine for transporting and spreading manure and/or other mainly non-liquid organic products or soil improvers (e.g. lime) on the field

Note 1 to entry: See examples in Annex A, Figures A.1, A.2 and A.3.

**3.2 load body**  
volume consisting of a platform with three walls and a spreading device at the rear able to contain the product for its transport and spreading

**3.3 conveyer device**  
device able to convey/move/carry the material in the load body to the spreading device, that are of three types: scraper floor, conveyer belt or load push/push-off device

**3.3.1 scraper floor**  
conveyor device made by two or more dragging chains and by a number of slats

**3.3.2 conveyer belt(s)**  
conveyor device made by belt(s)

**3.3.3 load push**  
push-off device  
conveyor device formed by a moveable wall for pushing the material in the load body to the spreading device

**3.4 rear spreading device**  
device made by rotary elements (e.g. rotors or discs) intended for spreading the product contained inside the load body

Note 1 to entry: See examples in Annex A, Figure A.4 and A.5.

**3.4.1 rear spreading device with rotor(s)**  
device formed by rotor(s) with vertical or horizontal rotation axe



### 3.4.2

#### rear spreading device with discs

device formed by two or more discs with vertical rotation axes

### 3.5

#### working tools of the spreading device

components (as teeth, saw-blades, etc.) fixed on spreading device for catching the product inside the load body, and spreading it

### 3.6

#### manure spreader with lateral spreading

manure spreader (3.1) that spreads laterally

Note 1 to entry: See examples in Annex A, Figure A.6.

### 3.7

#### entry point

point at which the conveyor chains enter the (chain) sprocket(s)

### 3.8

#### reverse movement of conveyor

movement of the conveyor opposite to the working direction for removal of disorders, such as blockages

## 4 List of significant hazards

Table 1 gives the significant hazard(s), the significant hazardous situation(s) and hazardous event(s) covered by this document that have been identified by risk assessment as being significant for this type of machine, and which require specific action by the designer or manufacturer to eliminate or reduce the risk.

Attention is drawn to the necessity to verify that the safety requirements specified in this document apply to each significant hazard presented by a given machine and to validate that the risk assessment is complete.

**Table 1 — List of significant hazards associated with manure spreaders**

No. <sup>a</sup>	Hazard, hazardous situation or hazardous event	Origin	Clause/subclause of EN ISO 4254-1:2009	Clause/subclause of this document
<b>A.1</b>	<b>Mechanical hazards</b>			
A.1.1	Crushing hazard	Controls	4.4.3; 5.1.3.2; 5.1.8; 6.1	5.2
		Access means	4.5.1.1.2; 4.5.1.2.5; 4.5.2.3; 4.6	—
		Working elements /conveyor/spreading devices	4.7	5.3; 5.5.1; 5.9; 7.1
		Service points, service and maintenance operations	4.8; 4.14.1; 4.14.3; 4.14.5; 4.14.6	5.5.2; 5.9; 7.1
		Roll-over	5.1.2.3	—
		Shearing and pinching points at the operator's work station	5.1.4	—
		Moving the machine	5.2	—
		Lack of stability	6.2	7.1
		Mounting of machines/coupling area	6.2.2; 6.2.3; 6.3	—

**Table 1** (continued)

No. <sup>a</sup>	Hazard, hazardous situation or hazardous event	Origin	Clause/subclause of EN ISO 4254-1:2009	Clause/subclause of this document
A.1.2	Shearing hazard	Controls	4.4.3; 5.1.3.1; 5.1.3.3; 5.1.8; 6.1	5.2
		Access means	4.5.1.1.2; 4.5.1.2.5; 4.5.2.3; 4.6	—
		Power transmission parts Working elements /conveyor/spreading devices	4.7	5.3; 5.5.1; 5.9; 7.1
		Service points, service and maintenance operations	4.8; 4.14.1; 4.14.3; 4.14.5; 4.14.6	5.5.2; 5.9; 7.1
		Shearing and pinching points at the operator's work station	5.1.4	—
		Moving the machine	5.2	—
		Lack of stability	6.2	7.1
		Mounting of machines	6.2.2; 6.2.3; 6.3	—
A.1.3	Cutting or severing hazard	Working elements /conveyor/spreading devices	4.7	5.2;; 5.3; 5.5.1; 5.5.2; 5.9; 7.1
A.1.4	Entanglement hazard	Power transmission parts Driving gear of spreading device	6.4	5.6; 5.8 5.7
		Working elements /conveyor/spreading devices	4.7	5.2; 5.3; 5.5.1; 5.5.2; 5.9; 7.1
		Starting/stopping the engine with engaged drive(s)	5.1.8	7.1; 7.2
A.1.5	Drawing-in or trapping hazard	Power transmission parts Driving gear	6.4	5.6; 5.8 5.7
		Working Elements/conveyor/spreading devices	4.7	5.2; 5.3; 5.5.1; 5.5.2; 5.9; 7.1
		Starting/stopping the engine with engaged drive(s)	5.1.8	7.1; 7.2
A.1.6	Impact hazard	Access means	4.5.1.2.5	—
		Steering system	5.1.3.1	—
A.1.7	Stabbing or puncture hazard	Spreading devices	4.7	5.9
		Projectiles		5.4
A.1.8	Friction or abrasion hazard	Controls	4.4.3; 5.1.3.2	
		Electrical equipment,	4.9.1	—
		Access means	4.5.1.1.2	—
A.1.9	High-pressure fluid injection or ejection hazard	Hydraulic components and fittings (e.g. rupture)	4.10; 6.5	—
<b>A.2</b>	<b>Electrical hazards</b>			
A.2.1	Contact of persons with live parts (direct contact)	Electrical equipment	4.9; 5.3, 6.5	—

Table 1 (continued)

No. <sup>a</sup>	Hazard, hazardous situation or hazardous event	Origin	Clause/subclause of EN ISO 4254-1:2009	Clause/subclause of this document
A.2.2	Contact of persons with parts which have become live under faulty conditions (indirect contact)	Electrical equipment	4.9.1	—
A.2.4	Thermal radiation or other phenomena such as the projection of molten particles and chemical effects from short circuits, overloads, etc.	Electrical equipment	4.9.2; 5.3.1	— —
<b>A.3</b>	<b>Thermal hazards</b>			
	Burns, scalds and other injuries by possible contact between persons and objects or materials with an extreme high or low temperature, by flames or explosions and also by the radiation of heat sources	Hydraulic system, operating fluids (e.g. fuel, hydraulic oil, engine coolant)	4.12	—
		Cab material	5.1.6	—
		Hot surfaces	5.5	—
<b>A.4</b>	<b>Hazards generated by noise</b>			
	Hearing loss (deafness), other physiological disorders (e.g. loss of balance, loss of awareness), accidents due to speech communication and acoustic warning signals	Noise	4.2	5.11
<b>A.5</b>	<b>Hazards generated by materials and substances</b>			
A.5.1	Hazards from contact with or inhalation of harmful fluids, gases, mists, fumes and dusts	Operating fluids (fuel tank, hydraulic systems, engine cooling system)	4.10; 5.4	—
		Cab material	5.1.6	—
		Battery	5.3.1	—
		Exhaust system	5.6	—
A.5.2	Fire or explosion hazard	Cab material	5.1.6	—
<b>A.6</b>	<b>Hazards generated by neglecting ergonomic principles in machinery design</b>			
A.6.1	Unhealthy postures or excessive effort	Controls	4.4	—
		Access means	4.5; 4.6	5.6
		Service and maintenance operations	4.14.2; 4.14.4	5.5.2; 5.9; 7.1
		operator's station	5.1.1; 5.1.2.1; 5.1.3;	—
A.6.2	Non- or inadequate consideration of hand–arm or foot–leg anatomy	Controls	4.4	5.2
		Access means	4.5; 4.6	5.6
		Operator's station	5.1	—
A.6.3	Neglected use of personal protective equipment	Operator's manual	8.1.3	7.1
A.6.4	Inadequate local lighting	Visibility	5.1.7.3	—
A.6.5	Mental overload and under load, stress	Controls	4.4	—
A.6.6	Human error, human behaviour	Controls	4.4	—
		Operator's manual	8.1	7.1
		Location and design of signs	8.2	7.2

**Table 1** (continued)

No. <sup>a</sup>	Hazard, hazardous situation or hazardous event	Origin	Clause/subclause of EN ISO 4254-1:2009	Clause/subclause of this document
A.6.7	Design, location or identification of manual controls	Design, location and identification of controls	4.4; 5.1.3; 6.1, 8.1.3.c)	—
<b>A.7</b>	<b>Combination of hazards</b>	Individual assemblies	4.13	5.7
		Operator's manual	8.1	7.1
<b>A.8</b>	<b>Unexpected start-up, unexpected overrun/overspeed</b>			
A.8.1	Failure/disorder of the control system	Service and maintenance	4.8	—
		Electrical equipment Connections	4.9 6.5	—
A.8.2	Restoration of energy supply after an interruption	Control	4.4; 6.1	—
A.8.3	External influences on electrical equipment	Cables Electrical/Electronic components	4.9.1 —	5.1.4
A.8.4	Other external influences (gravity, wind, etc.)	Stability	6.2.1.1; 6.2.1.2	7.1
A.8.6	Errors made by the operator (due to mismatch of machinery with human characteristics and abilities, see 8.6)	Design and location of controls	4.4; 6.1.2	—
		Access means	4.5, 4.6	—
		Operator's work station	5.1	—
		Moving the machine	5.2	—
		Service and maintenance systems	4.14	7.1
		Mounting system of machines	6.2; 6.3	7.1
		Missing or insufficient instructions in the operator's manual	8.1.3	7.1
<b>A.9</b>	<b>Impossibility of stopping the machine in the best possible conditions</b>	Control	4.4; 6.1	—
<b>A.11</b>	<b>Failure of energy supply</b>	Supports	4.8	7.1
		Electrical equipment Connections	4.9 6.5	—
<b>A.12</b>	<b>Failure of the control circuit</b>	Electrical equipment	4.9	—
<b>A.13</b>	<b>Errors of fitting</b>	Mounting of machines	6.2; 6.3	7.1
		Missing or insufficient instructions in the operator's manual	8.1.3	7.1
<b>A.14</b>	<b>Break-up (of parts) during operation</b>	Guards and barriers (strength)	4.7	—
		Supports	4.8	—
		Hydraulic components	4.10	—
		Pneumatic components	4.11	—
<b>A.15</b>	<b>Falling or ejected objects or fluids</b>	Supports	4.8	—
		Hydraulic components	4.10	—
		Projectiles		5.4

Table 1 (continued)

No. <sup>a</sup>	Hazard, hazardous situation or hazardous event	Origin	Clause/subclause of EN ISO 4254-1:2009	Clause/subclause of this document
A.16	Loss of stability/Overturning of the machine	Stability Roll over	6.2 5.1.2.3	7.1 —
A.17	Slip, trap and fall of persons (related to machinery)	Access means	4.5; 4.6	5.6
<b>Additional hazards, hazardous situations or hazardous events linked with mobility</b>				
<b>A.18</b>	<b>Related to the travelling function</b>			
A.18.1	Movement when starting the engine	Propulsion of the machine	5.1.2.3	—
		Starting/stopping the engine	5.1.8	—
A.18.2	Movement without a driver at the driving position	Propulsion of machine	5.1.2.3	—
		Starting/stopping the engine	5.1.8	—
A.18.4	Insufficient ability of machinery to be slowed down, stopped and immobilised	Propulsion of the machine	5.1.3.2	—
<b>A.19</b>	<b>Linked to the work position</b>			
A.19.1	Fall of persons during access to (or at/from) the work position	Access means	4.5; 4.6	5.6
A.19.2	Exhaust gases/lack of oxygen at the work position	Cabin	5.4.1; 5.6	—
A.19.3	Fire (flammability of the cab, lack of extinguishing means)	Cab material	5.1.6	—
A.19.4	Mechanical hazards at the working position: a) contact with wheels b) rollover c) break-up of parts rotating at high speed	Shearing /pinching points	4.4.3; 4.5.1.2.5; 5.1.4	5.5.1
		Wheels	4.5.1.2	5.5.2
		PTO drive shaft(s)	4.6.4	5.6
		Supports	4.8	—
		Roll over	5.1.2.3	—
		Projectiles		5.4
A.19.5	Insufficient visibility from the work positions	Visibility	5.1.7	—
A.19.6	Inadequate lighting	Provisions for installing of working lights	5.1.7	—
A.19.7	Inadequate seating	Operator's seat	5.1.2	—
A.19.8	Noise at work position	Working of the machine	4.2	5.11
A.19.9	Insufficient means of evacuation/emergency exit	Emergency exits	5.1.5	—
<b>A.20</b>	<b>Due to the control system</b>			
A.20.1	Inadequate location of manual controls	Controls	4.4; 4.8.1.2; 5.1.2.1; 6.1.1; 6.1.2	—
A.20.2	Inadequate design of manual controls and their mode of operation	Controls	4.4; 5.1.3; 5.1.8	—

**Table 1** (continued)

No. <sup>a</sup>	Hazard, hazardous situation or hazardous event	Origin	Clause/subclause of EN ISO 4254-1:2009	Clause/subclause of this document
<b>A.21</b>	<b>From handling the machine (lack of stability)</b>	Lack of stability of the machine when in operation Roll-over	6.2 5.1.2.3	5.7; 7.1
<b>A.22</b>	<b>Due to the power source and to the transmission of power</b>			
A.22.1	Hazards from the engine and the batteries	Starting/stopping the engine	5.1.8	—
		Battery	5.3	—
A.24.2	Hazards from transmission of power between machines	Power transmission	6.4 , 6.5	—
A.24.3	Hazards from coupling and towing	Mounting of machines Braking connection	6.2.2; 6.2.3; 6.3	— 7.1
		Missing or insufficient instructions in the operator's manual	8.1.3	7.1
<b>A.23</b>	<b>From/to third persons</b>			
A.23.1	Unauthorised start-up and use	Starting/stopping the engine Engagement of power transmission	5.1.8	7.1 5.3.1
A.23.2	Lack or inadequacy of visual or acoustic warning means	Visibility Warning	5.1.7	5.3.2; 7.1
<b>A.24</b>	<b>Insufficient instructions for the driver/operator</b>	Operator's manual	8.1	7.1

<sup>a</sup> With reference to EN ISO 4254-1:2009, Table A.1.

## 5 Safety requirements and/or protective measures

### 5.1 General

**5.1.1** Machinery shall comply with the safety requirements and/or protective measures of this clause.

In addition, the machine shall be designed according to the principles of EN ISO 12100 for relevant but not significant hazards which are not dealt with by this document.

**5.1.2** Unless otherwise specified in this document, the machine shall comply with the requirements of EN ISO 4254-1, EN 15811 and with requirements of appropriate Tables 1, 3, 4 and 6 of EN ISO 13857:2008.

**5.1.3** Openings in fixed guards and movable guards when closed shall comply with Table 4 of EN ISO 13857:2008.

Fixed guards that require routine removal for maintenance or adjustment shall be retained by fixings that are retained in the guard or machine.

**5.1.4** Machinery shall comply with EN ISO 14982 regarding electromagnetic compatibility.

**5.1.5** The compliance with the safety requirements and/or measures shall be verified in accordance with Clause 6.

## 5.2 Location of the manual controls

Manual controls, in particular those for speed adjustment of conveyor device, shall be located at a minimum distance of 850 mm from every unguarded movable element of the spreading device.

## 5.3 Prevention of unintentional contact with the moving spreading device

### 5.3.1 Self-propelled machines

For prevention of unintentional contact with the moving spreading device, self-propelled machines shall have a system that prevents engagement of the spreading device if the operator is not in the operator's work station and that automatically disengages the spreading device when the operator leaves the operator's work station.

The maximum delay time for triggering the disengagement shall be 3 s.

Spreading device starting shall require intentional reactivation by means other than the automatic spreading device disengagement control after stopping.

### 5.3.2 Mounted, semi-mounted and trailed machines

Technical measures shall be taken, at least, by means of an audible signal or flashing light located near the spreading device, to warn when the spreading device is running and the machine is not travelling.

Defect of signal shall be avoided, e.g. by associating its power to that of the spreading device.

Delay between stop of machine travel and signal emission shall be 6 s ( $\pm 2$  s).

Further investigations are to be carried out either to apply the requirement for self-propelled machines (see 5.3.1) to mounted, semi-mounted and trailed machines or establish other equally effective safety measures (e.g. moveable guard).

## 5.4 Protection against projectiles

Whatever type of rotor, manure spreaders that spread to the rear shall be fitted with a grid to protect the operator from projectiles.

The width of the grid shall be equal to that of the spreading device.

The grid shall have a minimum height of 2 600 mm from the ground level.

For self-propelled machines, the grid shall extend at least 1 000 mm above the SIP (as defined in Clause 3 of EN ISO 5353:1998) of the driver's seat, unless any other part of the machine provides equivalent protection.

The grid shall be at least 200 mm above the upper path of the spreading tools (independent of whether they are horizontal or vertical). This requirement does not apply if the height of the load body or of the grid is higher than 3 200 mm from the ground level.

The grid shall not allow penetration of a sphere with a diameter of 30 mm maximum and have the same level of safety to a steel grid having a wire diameter of 1,8 mm.

Fixed parts of the machines, e.g. load body can be considered as equivalent protection as the grid provided they comply with the above dimensioning requirements.

The maximum gap between the grid and the load body shall be 30 mm.

## **5.5 Conveyor**

### **5.5.1 Guarding**

#### **5.5.1.1 General**

For conveyor with slats, the access to shearing and crushing points shall be prevented by means of design or fixed guards.

If due to functional reasons, there is still access to shearing and crushing points, the following clauses shall be satisfied.

#### **5.5.1.2 Moving path of conveyor**

The moving path of the conveyor below the load body shall be covered at the front and at the sides over its entire length (see Figure 1).

Below the load body the distance between the conveyor slats and the fixed parts of the machine located in the transverse direction to the moving direction of the conveyor (e.g. frame components) except for guiding elements of the slat conveyor provided that they do not generate shearing or crushing hazards shall be at least 25 mm (see Figure 2).

Design of the lateral guard shall consider the possible slackening of the conveyor chains during use.

Remaining shearing and crushing points between the conveyor and fixed parts of the machine shall be identified. Such shearing and crushing points shall be identified by safety signs on the machine where foreseeable access could be gained to these shearing and crushing points. The safety signs and their position on the machine shall be indicated in the operator's manual. See also 7.1.w).



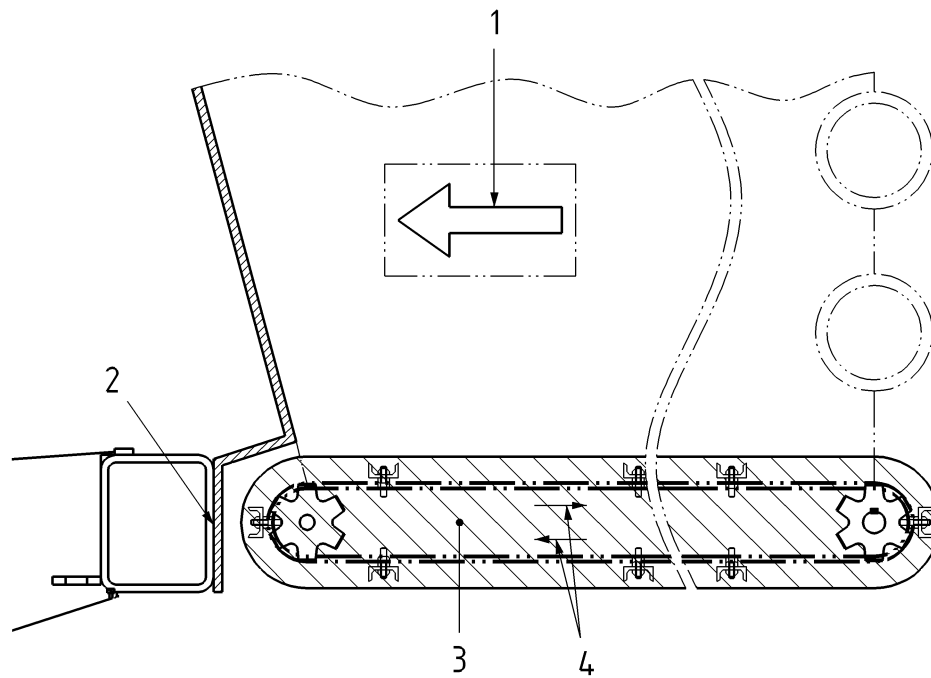

**Key**

- 1 direction of travel of machine
- 2 area to be guarded at the front
- 3 area to be guarded at the sides
- 4 moving direction of conveyor (upper and lower strand)

**Figure 1 — Guarding of moving path of conveyor**

Dimensions in millimetres

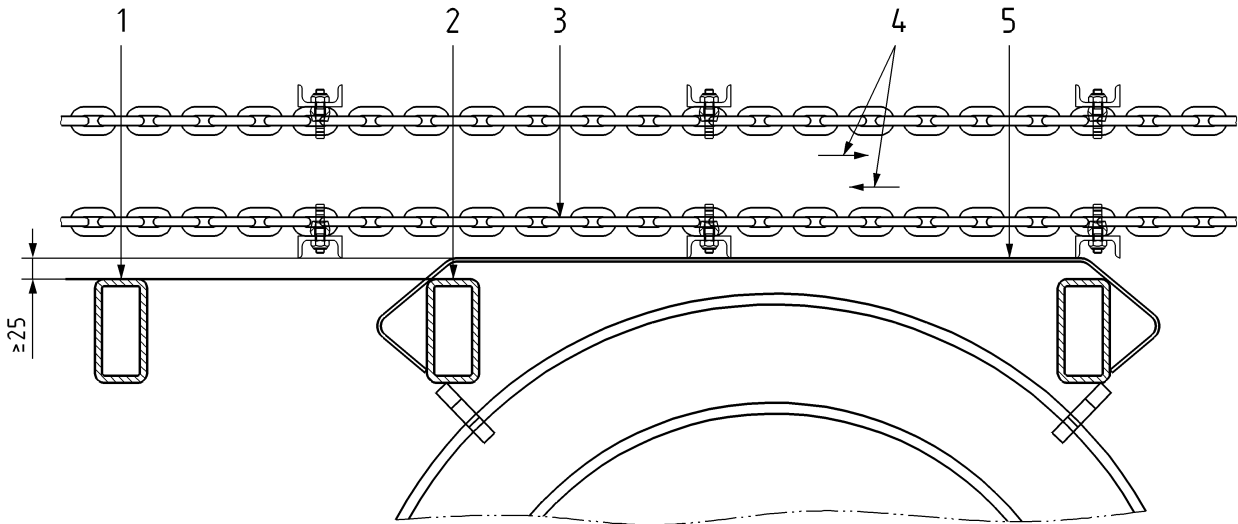

**a) side view**

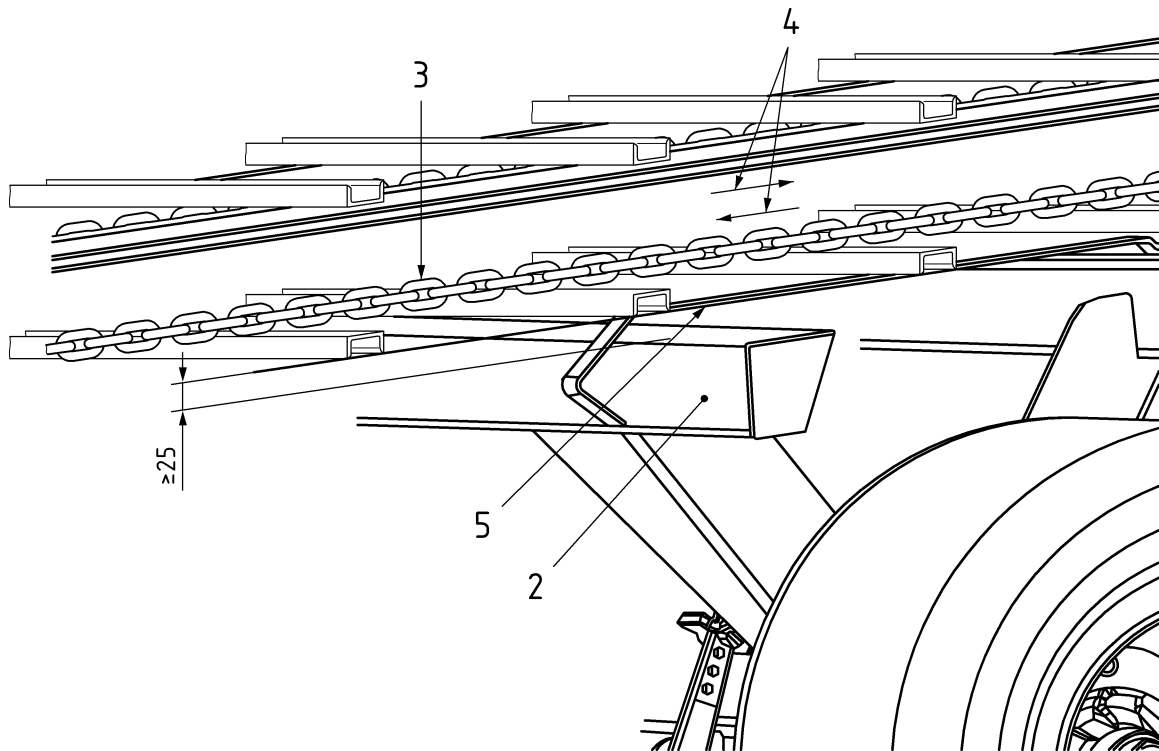

**b) perspective view**

**Key**

- 1 fixed part of the machine – component(s) of the frame
- 2 fixed part of the machine – chassis
- 3 lower strand of conveyor
- 4 moving direction of conveyor (upper and lower strand)
- 5 guiding elements for conveyor

**Figure 2 — Conveyor guarding below the load body**

### 5.5.1.3 Front turning points

Shearing and crushing points at a distance of less than 850 mm from the outer contour of the machine, which are directly accessible from the side of the machine, shall be guarded at the front turning points.

If direct access to the front turning points is possible, the horizontal distance between the foremost point of the front of the moving path of the conveyor and the fixed parts of the machine shall be at least 100 mm (see Figure 3 a)).

If access to the front turning points is only possible indirectly (e.g. by circumventing a guard), the horizontal distance between the foremost point of the moving path of the conveyor and the fixed parts of the machine may be minimized to 25 mm. In this case, the lower guard shall extend rearwards from the fixed parts at least to the vertical plane through the axle of the chain sprocket axle / deflection rolls. The distance between the moving path of the conveyor and the guard shall be at least 100 mm. The distance of 100 mm from the outer moving path of the conveyor to the guard shall at least be provided over a length of 130 mm from the rearward edge of the guard (see Figure 3 b)).

When operating in the spreading direction, the areas at the turning points of the conveyor where the chains run onto a sprocket or deflection roll shall be guarded. The guard shall prevent direct access to the crushing zones.

As far as a reverse movement of the conveyor is possible, the upper entry point of the conveyor inside the load body shall be guarded along its width. This does not apply if the machine is equipped with a hold-to-run control for the reverse operation of the conveyor.

Shearing and crushing hazards which may occur during contact of the conveyor slats with the loading platform or the guide plates at the turning points and which could not be avoided due to functional reasons, shall be identified by safety signs on the machines where foreseeable access could be gained to these shearing and crushing points. The safety signs and their position on the machine shall be indicated in the operator's manual. See also 7.1.w).

Dimensions in millimetres

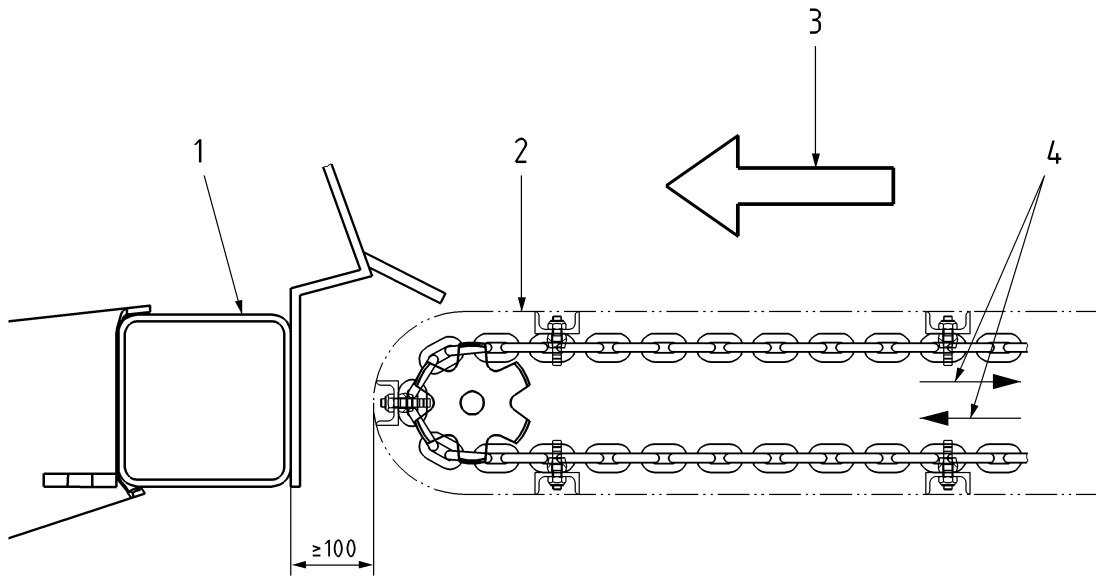

a) Guarding at direct access

Dimensions in millimetres

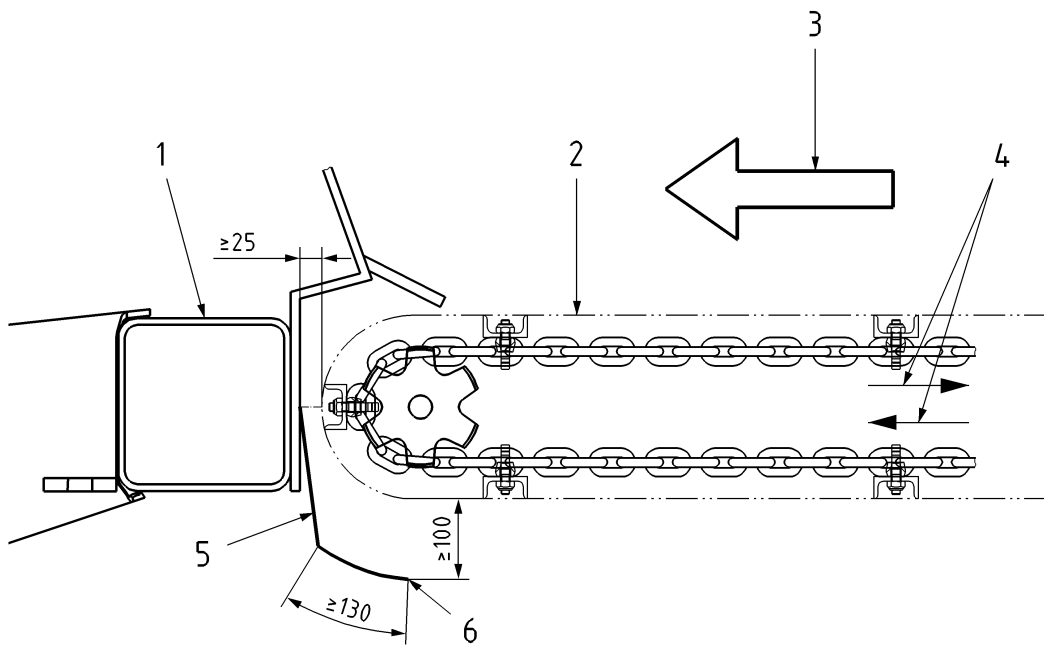

b) Guarding at indirect access

**Key**

- 1 fixed part of the machine (i.e. frame)
- 2 outer moving part of conveyor
- 3 direction of travel of machine
- 4 moving direction of conveyor (upper and lower strand)
- 5 guard
- 6 rearward edge of guard

**Figure 3 — Guarding of conveyor at front turning points**

#### 5.5.1.4 Rear turning points

Shearing and crushing points at a distance of less than 850 mm from the outer lateral edge of the machine which are directly accessible, shall be guarded at the rear turning points. This guarding can be achieved by guide plates that at the area of the turning leave a clearance between the guide plate and the slats of no more than 8 mm. The maximum clearance of 8 mm shall be maintained over the 180° to the rear of a vertical axis through the centre of the sprocket, see item 1 of key to Figure 4.

When operating in the spreading direction, the areas at the turning points of the conveyor where the chains run onto a sprocket or deflection roll shall be guarded. The guard shall prevent direct access to the crushing zones.

As far as a reverse movement of the conveyor is possible, the lower entry point of the conveyor below the load body shall be guarded along its width. This does not apply if the machine is equipped with a hold-to-run control for the reverse operation of the conveyor.

Shearing and crushing hazards which may occur during contact of the conveyor slats with the loading platform or the guide plates at the turning points and which could not be avoided due to functional reasons shall be identified by safety signs on the machines where foreseeable access could be gained to these shearing and crushing points. The safety signs and their position on the machine shall be indicated in the operator's manual. See also 7.1.w).

Dimensions in millimetres

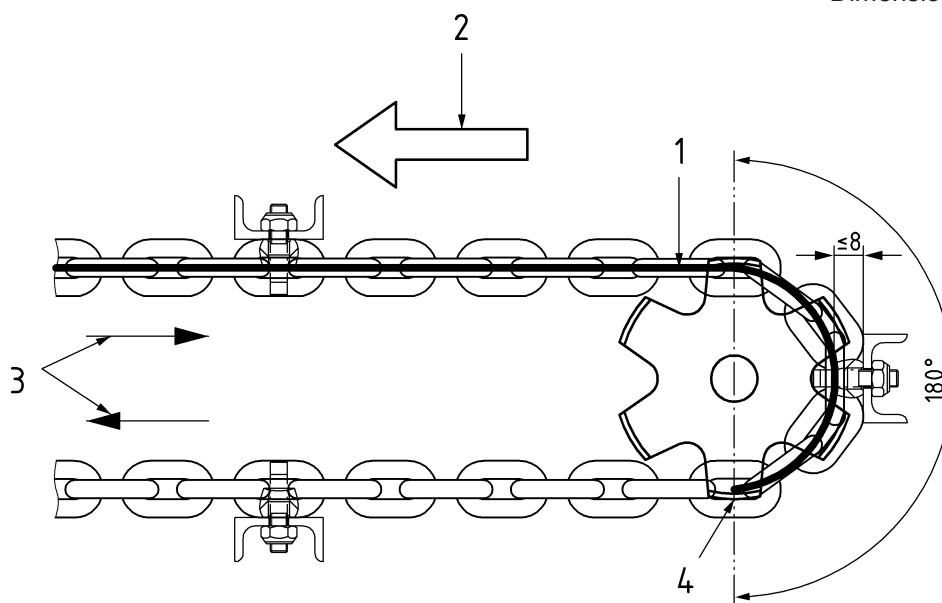

#### Key

- 1 guide plate
- 2 direction of travel of machine
- 3 moving direction of conveyor (upper and lower strand)
- 4 entry point during reverse movement

Figure 4 — Guarding of conveyor at rear turning points

#### 5.5.2 Adjustment of conveyor

The tension of the conveyor chains shall be adjustable without the operator having to get underneath the machine load body.

The requirements given in 5.5.1.3 shall be met in all adjustment positions of the device for adjusting the tension of the conveyor chains.

## **5.6 Means of access**

When the upper edge of the load body is at more than 1,60 m from the ground, access means shall be provided to enable the operator to check inside the load body. The vertical distance between the upper edge of the load body and the upper step of the access means shall be between 1 200 mm and 1 600 mm.

For machines with a power take-off (PTO) drive shaft above the drawbar, the means of access shall not be directly above the PTO drive shaft.

## **5.7 Removal of the spreading device**

A spreading device that can be removed shall be fitted with two clearly identifiable anchoring points for attachment of lifting appliances.

When the machine is designed so that it can be used without the spreading device, the driving gear of the spreading device which remains on the machine, shall be fitted with a guard. This guard shall be an integral part of the machine and shall provide guarding of the driving gear when the spreading device is removed.

## **5.8 Transmission shafts**

Transmission shafts beneath the machine load body shall be guarded against any contact.

## **5.9 Cleaning**

Cleaning shall be possible without the presence of the operator inside the load body. It shall be possible to operate the conveyor device while the spreading device is disengaged.

In order to clean easily and safely all spreading devices, the rotors shall be designed to allow their rotation without any external energy source, e.g. by a freewheel drive. See also 7.1.h).

The inside of the load body shall be designed such that the accumulation of residues, which need to be removed manually in order to retain the functionality of the machine, is minimized (e.g. by avoiding protruding parts, by providing a low friction lining to assist sliding of the material).

## **5.10 Special tools**

If special tools are necessary, e.g. for removing blockages, adjustment, maintenance, repair, they shall be supplied with the machine.

## **5.11 Noise**

### **5.11.1 Noise reduction by design**

Self-propelled machinery shall be designed so that the level of noise produced is reduced to the lowest level. The main sources that generate noise are:

- spreading devices;
- vibrating surfaces;
- the engine;
- transmission gears.

Machinery shall be designed and constructed considering available information and technical measurements to control noise on the projection phase, as described in EN ISO 11688-1.

NOTE EN ISO 11688-2 gives useful knowledge on processes that generate noise in the machines.

#### **5.11.2 Noise reduction by information**

If after taking all possible technical measures for reducing noise at the design stage a manufacturer considers that further protection of the operator is necessary, then adequate information shall be given in the operator's manual (see 7.1.u)).

#### **5.11.3 Noise emission values**

For sound power level determination and sound pressure level at the operator's station, the noise test code provided in EN ISO 4254-1:2009, Annex B shall be used.

## **6 Verification of safety requirements or protective measures**

See Table 2.

**Table 2 — List of safety requirements and/or protective measures and their verification**

Clause/subclause	Verification		
	Inspection <sup>a</sup>	Measurement <sup>b</sup>	Procedure/reference
<b>5.1.1</b>	X		
<b>5.1.2</b>	X	X	EN ISO 13857
<b>5.1.3</b>	X	X	EN ISO 13857
<b>5.1.4 EMC</b>		X	EN ISO 14982
<b>5.2 Location of the manual controls</b>		X	
<b>5.3 Prevention of unintentional contact with the moving spreading device</b>	X	X	
<b>5.4 Protection against projectiles</b>	X	X	
<b>5.5 Conveyor</b>	X	X	
<b>5.6 Means of access</b>	X	X	
<b>5.7 Removal of the spreading device</b>	X		
<b>5.8 Transmission shafts</b>	X		
<b>5.9 Cleaning</b>	X		
<b>5.10 Special tools</b>	X		
<b>5.11 Noise</b>		X	EN ISO 4254-1:2009, Annex B

<sup>a</sup> Inspection: visual check of the machine to see that everything is in place.  
<sup>b</sup> Measurement: determination of a value by using some form of device or instrument.

## **7 Information for use**

### **7.1 Operator's manual**

An operator's manual shall be provided by the manufacturer with each machine.

Comprehensive instructions and information on all aspects of maintenance and the safe use of the machine, including suitable clothing and personal protective equipment (PPE) requirements and the need for training, if necessary, shall be provided in the operator's manual.

The operator's manual shall comply with the requirements of this clause, 8.1 of EN ISO 4254-1:2009, 6.4 of EN ISO 12100:2010 and ISO 3600.

In particular, the following information and instructions shall be included:

- a) the machine shall be used by only one person. When the operator sees someone in the loading/spreading area, the operator shall stop the machine;



- b) a warning not to go near the spreading device and/or underneath the load body when the machine is working;
- c) necessity to use a drive shaft from the power take off that has a guard in good conditions;
- d) persons shall not enter the machine when the spreading device and/or conveyor is running;
- e) how to safely access the load body for maintenance and repair purposes;
- f) a requirement that the machine shall not be used to transport people or animals;
- g) no intervention shall be executed when the spreading devices are moving.

Maintenance and repair when manual intervention is required shall be carried out with the engine turned off, and:

- 1) the ignition key removed and retained; or
- 2) the power sources (e.g. PTO, hydraulic, electrical) disconnected.

For self-propelled spreaders, when manual intervention is required, the engine shall be stopped and the ignition key shall be removed and retained;

- h) procedures regarding cleaning (see 5.9). In particular:
  - 1) stating that no intervention is required inside the load body for cleaning the conveyor;
  - 2) stating that if rotating the spreading device is required for cleaning, this shall be done manually;
  - 3) explanation of the safe cleaning process of the load body including information about the operator position during this operation.
- i) application points for use with jacks when raising the machine shall be clearly indicated;
- j) instructions for removing blockages. When manual intervention is required see also g);
- k) when appropriate, instructions for the use of special tools supplied with the machine, e.g. for removing blockages, adjustment, maintenance, repair. When manual intervention is required see also g);
- l) use of devices for maintaining machine parts in a raised position during maintenance and servicing;
- m) warning about safety measures when the machine and its moving components are not in use and the use of supports to ensure stability when the machine is parked;
- n) risks associated with the removal and the assemblage of the spreading device and instructions for its correct handling;
- o) the nominal rotational frequency and the direction of rotation of the power input connection (PIC);
- p) admissible pressure and flow of the hydraulic circuit;
- q) the loading procedure of the manure spreader to be followed to ensure a sufficient stability during loading;
- r) warning that the manoeuvrability of the tractor is affected by the load, in particular when the load body is partially empty;

- s) how to change tools of the spreading device, with particular attention to pinching hazard between moving parts and fixed parts of the machine;
- t) verifying, before the use of the machine, the connection and correct operation of the braking system;
- u) concerning noise, for self-propelled machines:
  - 1) the A-weighted sound pressure level declared at the operator's station if it is over 70 dB(A); or that this level is lower or equal to 70 dB(A);
  - 2) the A-weighted sound power level declared of the machine; if the A-weighted sound pressure level at the operator's station is over 80 dB(A);
  - 3) the uncertainty of measurement;
  - 4) the reference to noise test code reported in Annex B of EN ISO 4254-1:2009;
  - 5) advices on the use of working condition in reduced noise mode and/or limited operating time, if necessary;
  - 6) the necessity to supply sound level declaration and to advise the use of earphones, if necessary.
- v) the need to avoid spreading manure in which there are ropes or wrapping material that could wrap around rotors, in order to reduce manual intervention for their removal;
- w) to not go underneath the machine when the conveyor is running;
- x) procedure for regular tensioning of the conveyor chains, if any;
- y) recommended safety distance during spreading in order to avoid projection hazards toward bystanders (e.g. stones, metallic parts).

## **7.2 Safety and instructional signs**

See 8.2 of EN ISO 4254-1:2009.

In particular, a safety sign shall be provided at the means of access or adjacent to it, to indicate that it is strictly forbidden to enter into the machine when it is working.

Clearly visible warnings, placed at the front of the machine, shall indicate that the engine shall be turned off and:

- the ignition key shall be removed and retained, or
- the power sources (e.g. PTO, hydraulic, or electrical) shall be disconnected

before any intervention (see 7.1 g)).

For self-propelled spreaders, a clearly visible warning placed in the cab shall indicate that the engine of the machine shall be turned off and the ignition key shall be removed and retained before any intervention (see 7.1 g)).

In accordance with 5.5.1.3 and 5.5.1.4, accessible remaining shearing and crushing points shall be identified by safety signs on the machine.

### 7.3 Marking

All machines shall be marked legibly and indelibly with at least the following minimum information:

- the business name and full address of the manufacturer and, where applicable, his authorized representative;
- year of construction;
- the designation of the machinery;
- designation of series or type;
- serial number, if any;
- unladen mass;
- spreading device mass;
- maximum mass allowed.

Application points for the use with lifting jacks shall be clearly marked on the machine, if not obvious, and additional information shall be provided in the operator's manual.

A sign on the machine shall be provided showing which measures are to be taken or how the machine is to be used to ensure stability.

## Annex A (informative)

### Illustrations of manure spreaders

#### A.1 Examples of manure spreaders with rear spreading device dealt with in present EN 690



Figure A.1 — Self-propelled manure spreader

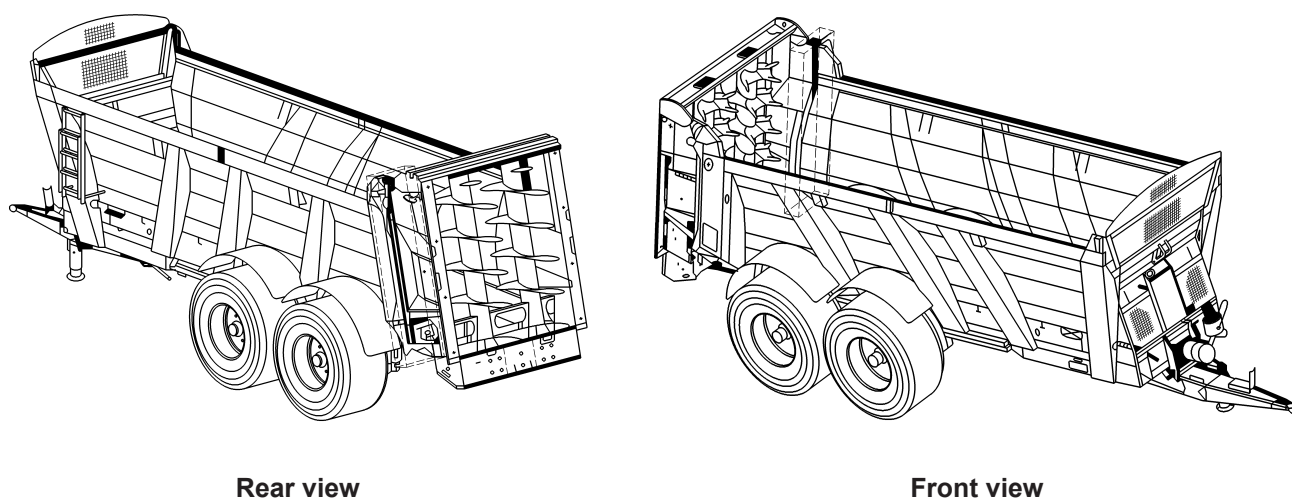

Rear view

Front view

Figure A.2 — Example of trailed manure spreader provided with a rear spreading device with vertical rotors

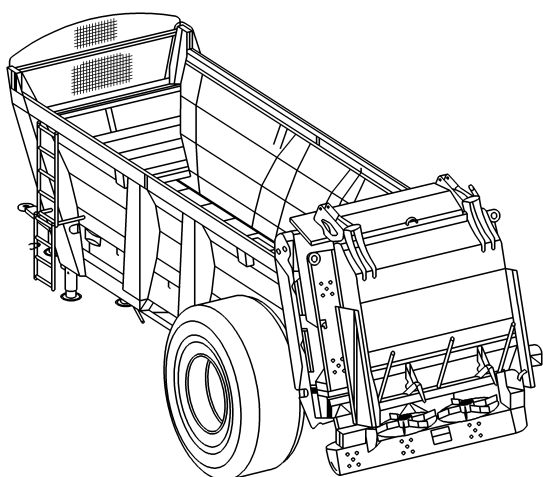

Rear view

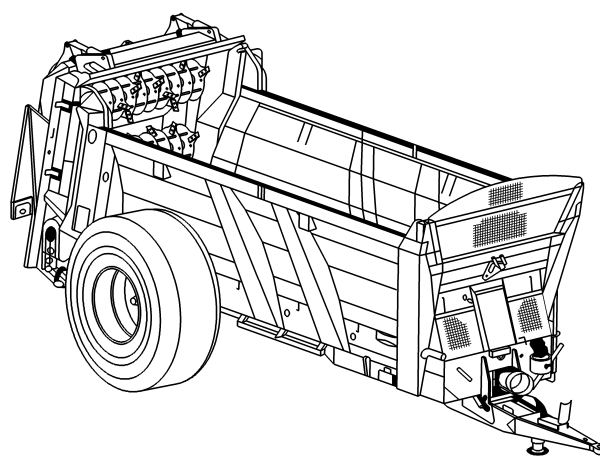

Front view

Figure A.3 — Example of trailed manure spreader provided with horizontal axes rotors combined with vertical axes disc

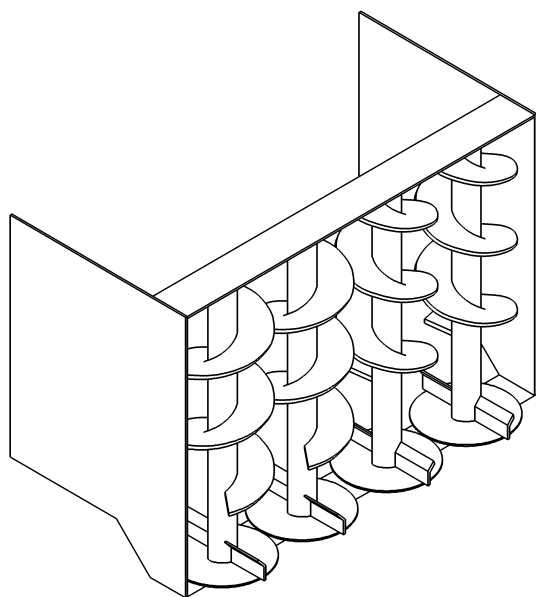

Four vertical axes rotors

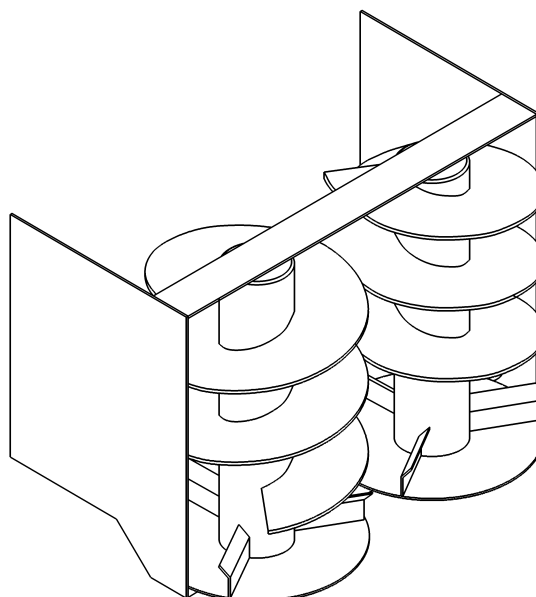

Two vertical axes rotors

Figure A.4 — Examples of vertical axes rotors and discs rear spreading devices

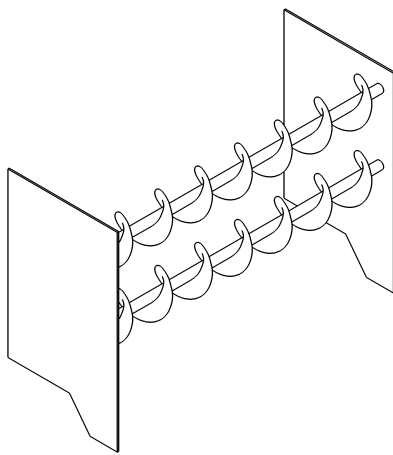

**Two horizontal axes rotors**

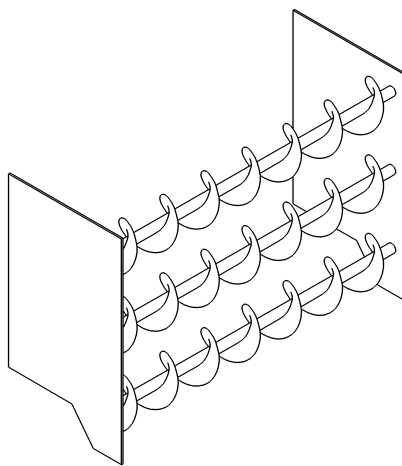

**Three horizontal axes rotors**

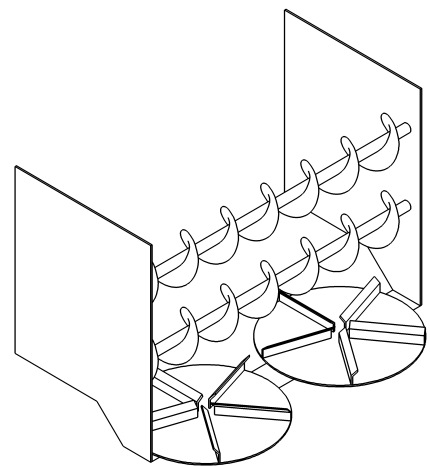

**Two horizontal axes rotors  
combined with vertical discs**

**Figure A.5 — Examples of horizontal axes rotors rear spreading devices**

**A.2 Examples of manure spreaders with lateral spreading – not dealt with in present EN 690**

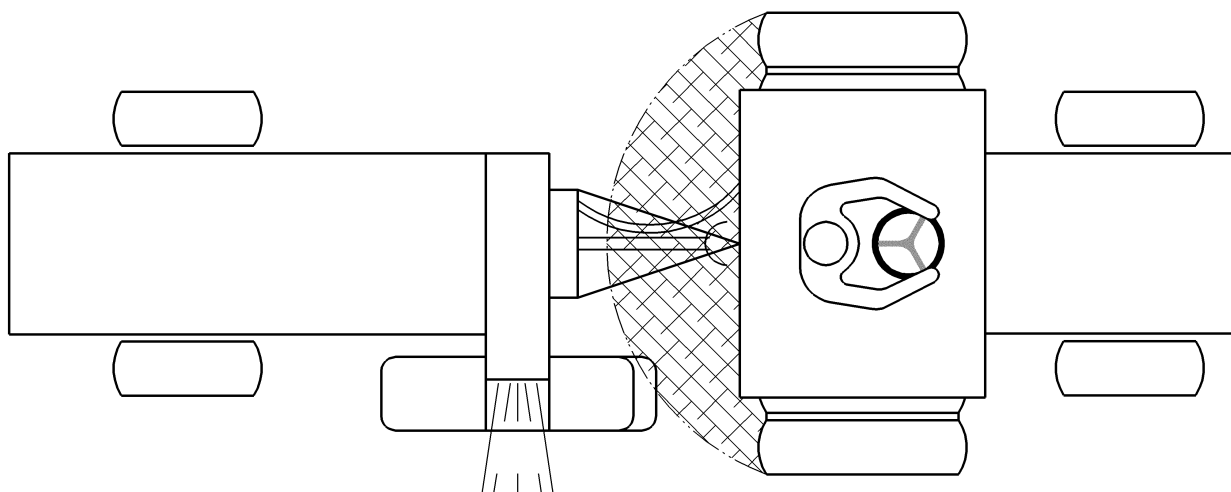

**a) Front lateral spreading**

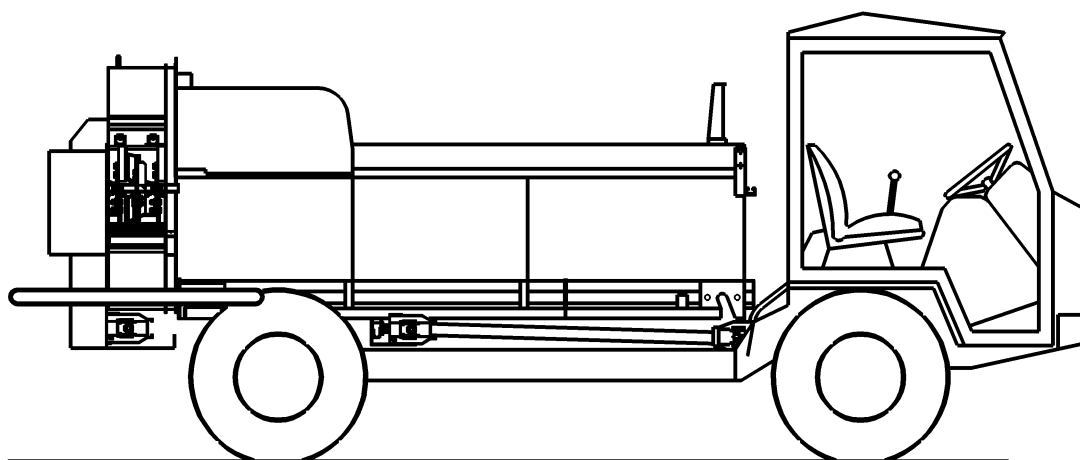

**b) Rear lateral spreading**

**Figure A.6 —Examples of manure spreader with lateral spreading**

## Annex ZA (informative)

### Relationship between this European Standard and the Essential Requirements of EU Directive 2006/42/EC on machinery

This European Standard has been prepared under a mandate given to CEN by the European Commission and the European Free Trade Association to provide one means to conform to Essential Requirements of the New Approach Machinery Directive 2006/42/EC.

Once this standard is cited in the Official Journal of the European Union under that Directive and has been implemented as a national standard in at least one Member State, compliance with the normative clauses of this standard confers, within the limits of the scope of this standard, a presumption of conformity with the relevant Essential Requirements, *except Essential Requirement(s) 1.5.9, 3.3.3; 3.4.3, 3.6.3.1 for self-propelled machines*, of that Directive *and associated EFTA regulations*.

**WARNING —** Other requirements and other EU Directives may be applicable to the product(s) falling within the scope of this standard.



## Bibliography

- [1] EN ISO 11688-2, *Acoustics — Recommended practice for the design of low-noise machinery and equipment — Part 2: Introduction to the physics of low-noise design (ISO/TR 11688-2)*
- [2] EN 13080, *Agricultural machinery — Manure spreaders — Environmental protection — Requirements and test methods*
- [3] EN ISO 16231-1, *Self-propelled agricultural machinery — Assessment of stability — Part 1: Principles (ISO 16231-1)*
- [4] ISO 11684, *Tractors, machinery for agriculture and forestry, powered lawn and garden equipment — Safety signs and hazard pictorials — General principles*





# British Standards Institution (BSI)

BSI is the national body responsible for preparing British Standards and other standards-related publications, information and services.

BSI is incorporated by Royal Charter. British Standards and other standardization products are published by BSI Standards Limited.

## About us

We bring together business, industry, government, consumers, innovators and others to shape their combined experience and expertise into standards-based solutions.

The knowledge embodied in our standards has been carefully assembled in a dependable format and refined through our open consultation process. Organizations of all sizes and across all sectors choose standards to help them achieve their goals.

## Information on standards

We can provide you with the knowledge that your organization needs to succeed. Find out more about British Standards by visiting our website at [bsigroup.com/standards](http://bsigroup.com/standards) or contacting our Customer Services team or Knowledge Centre.

## Buying standards

You can buy and download PDF versions of BSI publications, including British and adopted European and international standards, through our website at [bsigroup.com/shop](http://bsigroup.com/shop), where hard copies can also be purchased.

If you need international and foreign standards from other Standards Development Organizations, hard copies can be ordered from our Customer Services team.

## Subscriptions

Our range of subscription services are designed to make using standards easier for you. For further information on our subscription products go to [bsigroup.com/subscriptions](http://bsigroup.com/subscriptions).

With **British Standards Online (BSOL)** you'll have instant access to over 55,000 British and adopted European and international standards from your desktop. It's available 24/7 and is refreshed daily so you'll always be up to date.

You can keep in touch with standards developments and receive substantial discounts on the purchase price of standards, both in single copy and subscription format, by becoming a **BSI Subscribing Member**.

**PLUS** is an updating service exclusive to BSI Subscribing Members. You will automatically receive the latest hard copy of your standards when they're revised or replaced.

To find out more about becoming a BSI Subscribing Member and the benefits of membership, please visit [bsigroup.com/shop](http://bsigroup.com/shop).

With a **Multi-User Network Licence (MUNL)** you are able to host standards publications on your intranet. Licences can cover as few or as many users as you wish. With updates supplied as soon as they're available, you can be sure your documentation is current. For further information, email [bsmusales@bsigroup.com](mailto:bsmusales@bsigroup.com).

## BSI Group Headquarters

389 Chiswick High Road London W4 4AL UK

## Revisions

Our British Standards and other publications are updated by amendment or revision.

We continually improve the quality of our products and services to benefit your business. If you find an inaccuracy or ambiguity within a British Standard or other BSI publication please inform the Knowledge Centre.

## Copyright

All the data, software and documentation set out in all British Standards and other BSI publications are the property of and copyrighted by BSI, or some person or entity that owns copyright in the information used (such as the international standardization bodies) and has formally licensed such information to BSI for commercial publication and use. Except as permitted under the Copyright, Designs and Patents Act 1988 no extract may be reproduced, stored in a retrieval system or transmitted in any form or by any means – electronic, photocopying, recording or otherwise – without prior written permission from BSI. Details and advice can be obtained from the Copyright & Licensing Department.

## Useful Contacts:

### Customer Services

**Tel:** +44 845 086 9001

**Email (orders):** [orders@bsigroup.com](mailto:orders@bsigroup.com)

**Email (enquiries):** [cservices@bsigroup.com](mailto:cservices@bsigroup.com)

### Subscriptions

**Tel:** +44 845 086 9001

**Email:** [subscriptions@bsigroup.com](mailto:subscriptions@bsigroup.com)

### Knowledge Centre

**Tel:** +44 20 8996 7004

**Email:** [knowledgecentre@bsigroup.com](mailto:knowledgecentre@bsigroup.com)

### Copyright & Licensing

**Tel:** +44 20 8996 7070

**Email:** [copyright@bsigroup.com](mailto:copyright@bsigroup.com)



...making excellence a habit.™