

Non-destructive testing — Ultrasonic examination

Part 6 — Time-of-flight diffraction technique as a method for detection and sizing of discontinuities

ICS 19.100

National foreword

This British Standard is the UK implementation of EN 583-6:2008. It supersedes BS 7706:1993 and DD ENV 583-6:2000 which are withdrawn.

The UK participation in its preparation was entrusted to Technical Committee WEE/46, Non-destructive testing.

A list of organizations represented on this committee can be obtained on request to its secretary.

This publication does not purport to include all the necessary provisions of a contract. Users are responsible for its correct application.

Compliance with a British Standard cannot confer immunity from legal obligations.

This British Standard was published under the authority of the Standards Policy and Strategy Committee on 31 March 2009

© BSI 2009

ISBN 978 0 580 58071 0

Amendments/corrigenda issued since publication

Date	Comments

EUROPEAN STANDARD

EN 583-6

NORME EUROPÉENNE

EUROPÄISCHE NORM

December 2008

ICS 19.100

Supersedes ENV 583-6:2000

English Version

Non-destructive testing - Ultrasonic examination - Part 6: Time-of-flight diffraction technique as a method for detection and sizing of discontinuities

Essais non destructifs - Contrôle ultrasonore - Partie 6:
Technique de diffraction du temps de vol utilisée comme
méthode de détection et de dimensionnement des
discontinuités

Zerstörungsfreie Prüfung - Ultraschallprüfung - Teil 6:
Beugungslaufzeittechnik, eine Technik zum Auffinden und
Ausmessen von Inhomogenitäten

This European Standard was approved by CEN on 29 October 2008.

CEN members are bound to comply with the CEN/CENELEC Internal Regulations which stipulate the conditions for giving this European Standard the status of a national standard without any alteration. Up-to-date lists and bibliographical references concerning such national standards may be obtained on application to the CEN Management Centre or to any CEN member.

This European Standard exists in three official versions (English, French, German). A version in any other language made by translation under the responsibility of a CEN member into its own language and notified to the CEN Management Centre has the same status as the official versions.

CEN members are the national standards bodies of Austria, Belgium, Bulgaria, Cyprus, Czech Republic, Denmark, Estonia, Finland, France, Germany, Greece, Hungary, Iceland, Ireland, Italy, Latvia, Lithuania, Luxembourg, Malta, Netherlands, Norway, Poland, Portugal, Romania, Slovakia, Slovenia, Spain, Sweden, Switzerland and United Kingdom.



EUROPEAN COMMITTEE FOR STANDARDIZATION
COMITÉ EUROPÉEN DE NORMALISATION
EUROPÄISCHES KOMITEE FÜR NORMUNG

Management Centre: rue de Stassart, 36 B-1050 Brussels

Contents

	Page
Foreword.....	4
1 Scope	5
2 Normative references	5
3 Terms, definitions, symbols and abbreviations	6
3.1 Terms and definitions	6
3.2 Abbreviations	6
3.3 Symbols	6
4 General.....	7
4.1 Principle of the technique.....	7
4.2 Requirements for surface condition and couplant	9
4.3 Materials and process type.....	9
5 Qualification of personnel	9
6 Equipment requirements	9
6.1 Ultrasonic equipment and display	9
6.2 Ultrasonic probes	10
6.3 Scanning mechanisms	11
7 Equipment set-up procedures.....	11
7.1 General.....	11
7.2 Probe choice and probe separation.....	12
7.2.1 Probe selection	12
7.2.2 Probe separation.....	13
7.3 Time window setting	13
7.4 Sensitivity setting	13
7.5 Scan resolution setting	14
7.6 Setting of scanning speed	14
7.7 Checking system performance	14
8 Interpretation and analysis of data	14
8.1 Basic analysis of discontinuities	14
8.1.1 General.....	14
8.1.2 Characterisation of discontinuities.....	14
8.1.3 Estimation of discontinuity position.....	15
8.1.4 Estimation of discontinuity length.....	15
8.1.5 Estimation of discontinuity depth and height	16
8.2 Detailed analysis of discontinuities.....	16
8.2.1 General.....	16
8.2.2 Additional scans	17
8.2.3 Additional algorithms.....	18
9 Detection and sizing in complex geometries.....	18
10 Limitations of the technique.....	18
10.1 General.....	18
10.2 Accuracy and resolution.....	19
10.2.1 General.....	19
10.2.2 Errors in the lateral position.....	19
10.2.3 Timing errors.....	19
10.2.4 Errors in sound velocity.....	19
10.2.5 Errors in probe centre separation.....	19
10.2.6 Spatial resolution.....	20
10.3 Dead zones	20

11	TOFD examination without data recording.....	20
12	Test procedure.....	21
13	Test report.....	21
Annex A (normative) Reference blocks.....		22
Bibliography.....		23

Foreword

This document (EN 583-6:2008) has been prepared by Technical Committee CEN/TC 138 "Non-destructive testing", the secretariat of which is held by AFNOR.

This European Standard shall be given the status of a national standard, either by publication of an identical text or by endorsement, at the latest by June 2009, and conflicting national standards shall be withdrawn at the latest by June 2009.

Attention is drawn to the possibility that some of the elements of this document may be the subject of patent rights. CEN [and/or CENELEC] shall not be held responsible for identifying any or all such patent rights.

This document supersedes ENV 583-6:2000.

The relevant changes from the previous edition are as follows:

- the terminology was revised;
- the references were updated.

EN 583, *Non-destructive testing — Ultrasonic examination* consists of the following parts:

- EN 583-1, *Non-destructive testing — Ultrasonic examination — Part 1: General principles*
- EN 583-2, *Non-destructive testing — Ultrasonic examination — Part 2: Sensitivity and range setting*
- EN 583-3, *Non-destructive testing — Ultrasonic examination — Part 3: Transmission technique*
- EN 583-4, *Non-destructive testing — Ultrasonic examination — Part 4: Examination for discontinuities perpendicular to the surface*
- EN 583-5, *Non-destructive testing — Ultrasonic examination — Part 5: Characterization and sizing of discontinuities*
- EN 583-6, *Non-destructive testing — Ultrasonic examination — Part 6: Time-of-flight diffraction technique as a method for detection and sizing of discontinuities*

According to the CEN/CENELEC Internal Regulations, the national standards organizations of the following countries are bound to implement this European Standard: Austria, Belgium, Bulgaria, Cyprus, Czech Republic, Denmark, Estonia, Finland, France, Germany, Greece, Hungary, Iceland, Ireland, Italy, Latvia, Lithuania, Luxembourg, Malta, Netherlands, Norway, Poland, Portugal, Romania, Slovakia, Slovenia, Spain, Sweden, Switzerland and the United Kingdom.

1 Scope

This European Standard defines the general principles for the application of the Time-Of-Flight Diffraction (TOFD) technique for both detection and sizing of discontinuities in low alloyed carbon steel components. It could also be used for other types of materials, provided the application of the TOFD technique is performed with necessary consideration of geometry, acoustical properties of the materials and the sensitivity of the examination.

Although it is applicable, in general terms, to discontinuities in materials and applications covered by EN 583-1, it contains references to the application on welds. This approach has been chosen for reasons of clarity as to the ultrasonic probe positions and directions of scanning.

Unless otherwise specified in the referencing documents, the minimum requirements of this standard are applicable.

Unless explicitly stated otherwise, this standard is applicable to the following product classes as defined in EN 583-2:

- class 1, without restrictions;
- classes 2 and 3, restrictions will apply as stated in Clause 9.

The inspection of products of classes 4 and 5 will require special procedures. These are addressed in Clause 9 as well.

The techniques to use TOFD for weld inspection are described in CEN/TS 14751.

The related acceptance criteria are given in prEN 15617.

2 Normative references

The following referenced documents are indispensable for the application of this document. For dated references, only the edition cited applies. For undated references, the latest edition of the referenced document (including any amendments) applies.

EN 473, *Non-destructive testing — Qualification and certification of NDT personnel — General principles*

EN 583-1, *Non-destructive testing — Ultrasonic examination — Part 1: General principles*

EN 583-2, *Non-destructive testing — Ultrasonic examination — Part 2: Sensitivity and range setting*

EN 12668-1, *Non-destructive testing — Characterization and verification of ultrasonic examination equipment — Part 1: Instruments*

EN 12668-2, *Non-destructive testing — Characterization and verification of ultrasonic examination equipment — Part 2: Probes*

EN 12668-3, *Non-destructive testing — Characterization and verification of ultrasonic examination equipment — Part 3: Combined equipment*

3 Terms, definitions, symbols and abbreviations

3.1 Terms and definitions

For the purposes of this document, the following terms and definitions apply.

3.1.1

scanning surface dead zone

zone where indications may be obscured due to the interface echo (lateral wave)

3.1.2

back wall dead zone

dead zone where signals may be obscured by the presence of the back wall echo

3.1.3

A-scan

display of the ultrasonic signal amplitude as a function of time

3.1.4

B-scan

display of the time-of-flight of the ultrasonic signal as a function of probe displacement

3.1.5

non-parallel scan

scan perpendicular to the ultrasonic beam direction (see Figure 4)

3.1.6

parallel scan

scan parallel to the ultrasonic beam direction (see Figure 5)

3.2 Abbreviations

— TOFD: Time-Of-Flight Diffraction

3.3 Symbols

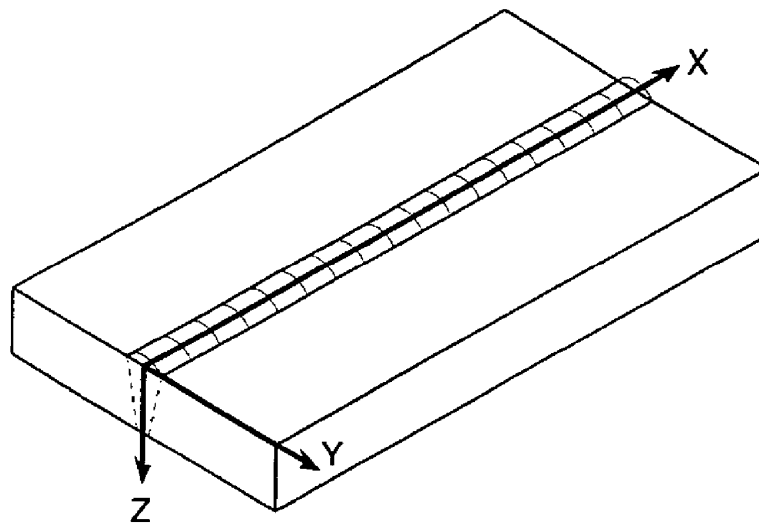

Figure 1 — Coordinate definition

x coordinate parallel to the scanning surface and parallel to a predetermined reference line. In case of weld inspection this reference line should coincide with the weld. The origin of the

axes may be defined as best suits the specimen under examination (see Figure 1);

Δx	discontinuity length;
y	coordinate parallel to the scanning surface, perpendicular to the predetermined reference line (see Figure 1);
δy	error in lateral position;
z	coordinate perpendicular to the scanning surface (see Figure 1);
Δz	discontinuity height;
d	depth of a discontinuity tip below the scanning surface;
δd	error in depth;
D_{ds}	scanning-surface dead zone;
D_{dw}	back wall dead zone;
c	sound velocity;
δc	error in sound velocity;
R	spatial resolution;
t	time-of-flight from the transmitter to the receiver;
Δt	time-of-flight difference between the lateral wave and a second ultrasonic signal;
δt	error in time-of-flight;
t_d	time-of-flight at depth d ;
t_p	duration of the ultrasonic pulse measured at 10 % of the peak amplitude;
t_w	time-of-flight of the back wall echo;
S	half the distance between the index points of two ultrasonic probes;
δS	error in half the probe separation;
W	wall thickness.

4 General

4.1 Principle of the technique

The TOFD technique relies on the interaction of ultrasonic waves with the tips of discontinuities. This interaction results in the emission of diffracted waves over a large angular range. Detection of the diffracted waves makes it possible to establish the presence of the discontinuity. The time-of-flight of the recorded signals is a measure for the height of the discontinuity, thus enabling sizing of the defect. The dimension of the discontinuity is always determined from the time-of-flight of the diffracted signals. The signal amplitude is not used in size estimation.

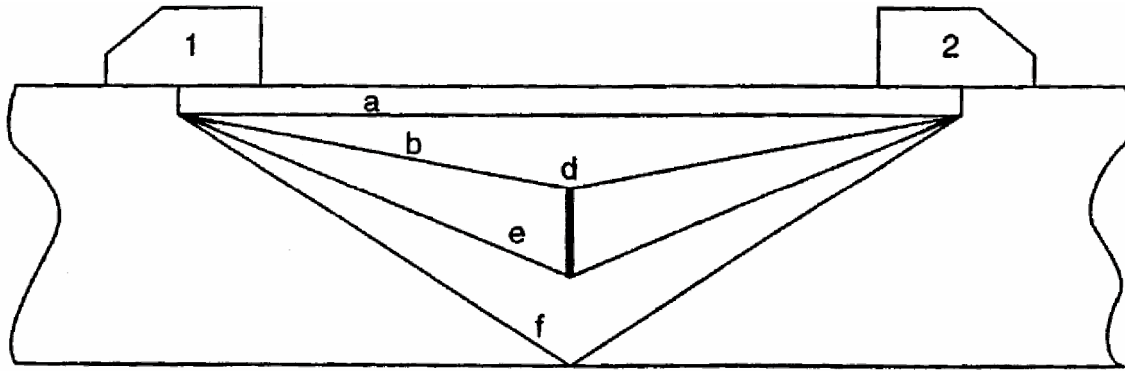

Key

- | | | | |
|---|--------------|---|----------------|
| 1 | transmitter | d | discontinuity |
| 2 | receiver | e | lower tip |
| a | lateral wave | f | back wall echo |
| b | upper tip | | |

Figure 2 — Basic TOFD configuration

The basic configuration for the TOFD technique consists of a separate ultrasonic transmitter and receiver (see Figure 2). Wide-angle beam compression wave probes are normally used since the diffraction of ultrasonic waves is only weakly dependent on the orientation of the discontinuity tip. This enables the inspection of a certain volume in one scan. However, restrictions apply to the size of the volume that can be inspected during a single scan (see 7.2).

The first signal to arrive at the receiver after emission of an ultrasonic pulse is usually the lateral wave which travels just beneath the upper surface of the test specimen.

In the absence of discontinuities, the second signal to arrive at the receiver is the back wall echo.

These two signals are normally used for reference purposes. If mode conversion is neglected, any signals generated by discontinuities in the material should arrive between the lateral wave and the back wall echo, since the latter two correspond, respectively, to the shortest and longest paths between transmitter and receiver. For similar reasons the diffracted signal generated at the upper tip of a discontinuity will arrive before the signal generated at the lower tip of the discontinuity. A typical pattern of indications (A-scan) is shown in Figure 3. The height of the discontinuity can be deduced from the difference in time-of-flight of the two diffracted signals (see 8.1.5). Note the phase reversal between the lateral wave and the back wall echo, and between echoes of the upper and lower tip of the discontinuity.

Where access to both surfaces of the specimen is possible and discontinuities are distributed throughout the specimen thickness, scanning from both surfaces will improve the overall precision, particularly in regard to discontinuities near the surfaces.

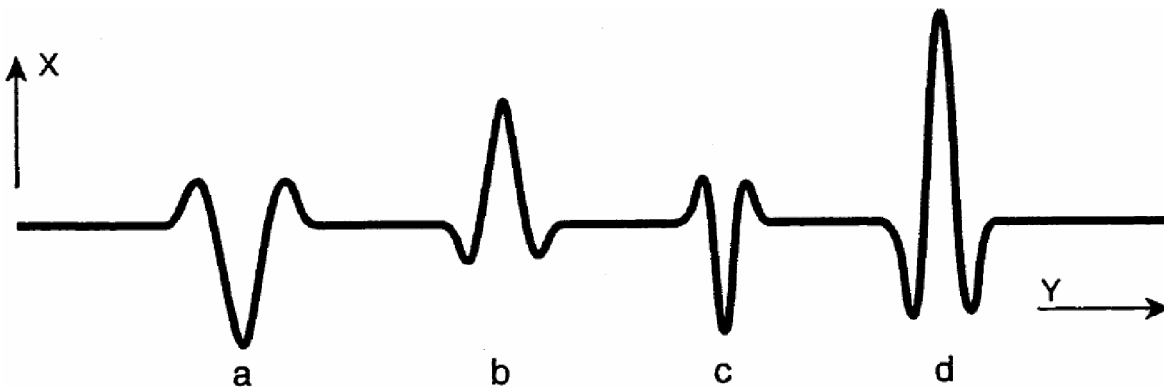

Key

X	amplitude	b	upper tip
Y	time	c	lower tip
a	lateral wave	d	back wall echo

Figure 3 — Schematic A-scan of an embedded discontinuity

4.2 Requirements for surface condition and couplant

Care shall be taken that the surface condition meets at least the requirements stated in EN 583-1. Since the diffracted signals may be weak, the degradation of signal quality due to poor surface condition will have a severe impact on inspection reliability.

Different coupling media can be used, but their type shall be compatible with the materials to be examined. Examples are: water (possibly containing an agent e.g. wetting, anti-freeze, corrosion inhibitor), contact paste, oil, grease, cellulose paste containing water, etc.

The characteristics of the coupling medium shall remain constant throughout the examination. It shall be suitable for the temperature range in which it will be used.

4.3 Materials and process type

Due to the relatively low signal amplitudes that are used in the TOFD technique, the method can be applied routinely on materials with relatively low levels of attenuation and scatter for ultrasonic waves. In general, application on unalloyed and low alloyed carbon steel components and welds is possible, but also on fine grained austenitic steels and aluminium.

Coarse-grained materials and materials with significant anisotropy however, such as cast iron, austenitic weld materials and high-nickel alloys, will require additional validation and additional data-processing.

By mutual agreement, a representative test specimen with artificial and/or natural discontinuities can be used to confirm inspectability. Remember that diffraction characteristics of artificial defects can differ significantly from those of real defects.

5 Qualification of personnel

Personnel performing examinations with the TOFD technique shall, as a minimum, be qualified in accordance with EN 473, and shall have received additional training and examination on the use of the TOFD technique on the product classes to be tested, as specified in a written practice.

6 Equipment requirements

6.1 Ultrasonic equipment and display

Ultrasonic equipment used for the TOFD technique shall, as a minimum, comply with the requirements of EN 12668-1, EN 12668-2 and EN 12668-3.

In addition, the following requirements shall apply:

- receiver bandwidth shall, as a minimum, range between 0,5 and 2 times the nominal probe frequency at -6 dB, unless specific materials and product classes require a larger bandwidth. Appropriate band filters can be used;
- transmitting pulse can either be unipolar or bipolar. The rise time shall not exceed 0,25 times the period corresponding to the nominal probe frequency;

- unrectified signals shall be digitised with a sampling rate of at least six times the nominal probe frequency;
- for general applications, combinations of ultrasonic equipment and scanning mechanisms (see 6.3) shall be capable of acquiring and digitizing signals with a rate of at least one A-scan per 1 millimetre scan length. Data acquisition and scanning mechanism movement shall be synchronized for this purpose;
- to select an appropriate portion of the time base within which A-scans are digitized, a window with programmable position and length shall be present. Window start shall be programmable between 0 μ s and 200 μ s from the transmitting pulse, window length shall be programmable between 5 μ s and 100 μ s. In this way, the appropriate signals (lateral or creeping wave, back wall signal, one or more mode converted signals as described in 4.1) can be selected to be digitized and displayed;
- digitised A-scans should be displayed in amplitude related grey or single-colour levels, plotted adjacently to form a B-scan. See Figures 4 and 5 for typical B-scans of non-parallel and parallel scans respectively. The number of grey or single-colour scales should at least be 64;
- for archiving purposes, the equipment shall be capable of storing all A-scans or B-scans (as appropriate) on a magnetic or optical storage medium such as hard disk, tape or optical disk. For reporting purposes, it shall be capable of making hard copies of A-scans or B-scans (as appropriate);
- equipment should be capable of performing signal averaging.

In order to achieve the relatively high gain settings required for typical TOFD-signals, a pre-amplifier may be used, which should have a flat response over the frequency range of interest. This pre-amplifier shall be positioned as close as possible to the receiving probe.

Additional requirements regarding features for basic and advanced analysis of discontinuities are described in Clause 8.

6.2 Ultrasonic probes

Ultrasonic probes used for the TOFD technique shall comply with at least the following requirements:

- number of probes: 2 (transmitter and receiver);
- type: any suitable probe (see 7.2);
- wave mode: usually compression wave; the use of shear wave probes is more complex but may be agreed upon in special cases;
- both probes shall have the same centre frequency within a tolerance of ± 20 %; for details on probe frequency selection, see 7.2;
- pulse length of both the lateral wave and the back wall echo shall not exceed two cycles, measured at 10 % of the peak amplitude;
- pulse repetition rate shall be set such that no interference occurs between signals caused by successive transmission pulses.

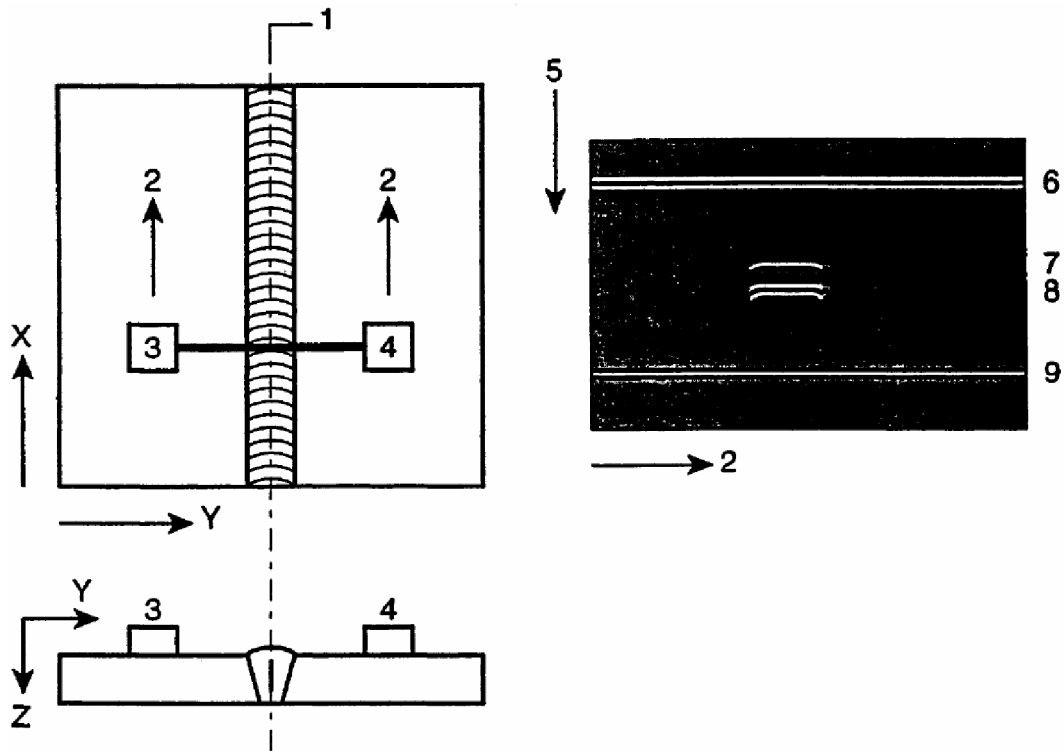

Key

- | | | | |
|---|---|---|-------------------------|
| 1 | reference line | 6 | lateral wave |
| 2 | direction of probe displacement (x-direction) | 7 | discontinuity upper tip |
| 3 | transmitter | 8 | discontinuity lower tip |
| 4 | receiver | 9 | back wall reflection |
| 5 | transit time (through wall extent) | | |

Figure 4 — Non-parallel scan, with the typical direction of probe displacement shown on the left and the corresponding B-scan shown on the right

6.3 Scanning mechanisms

Scanning mechanisms shall be used to maintain a constant distance and alignment between the index points of the two probes.

An additional function of scanning mechanisms is to provide the ultrasonic equipment with probe position information in order to enable the generation of position-related B-scans. Information on probe position can be provided by means of e.g. incremental magnetic or optical encoders, or potentiometers.

Scanning mechanisms in TOFD can either be motor or manually driven. They shall be guided by means of a suitable guiding mechanism (steel band, belt, automatic track following systems, guiding wheels, etc.).

Guiding accuracy with respect to the centre of a reference line (e.g. the centre line of a weld) should be kept within a tolerance of $\pm 10\%$ of the probe index separation (probe centre separation PCS).

7 Equipment set-up procedures

7.1 General

Probe selection and probe configuration are important equipment set-up parameters. They largely determine the overall accuracy, the signal-to-noise ratio and the coverage of the region of interest of the TOFD technique.

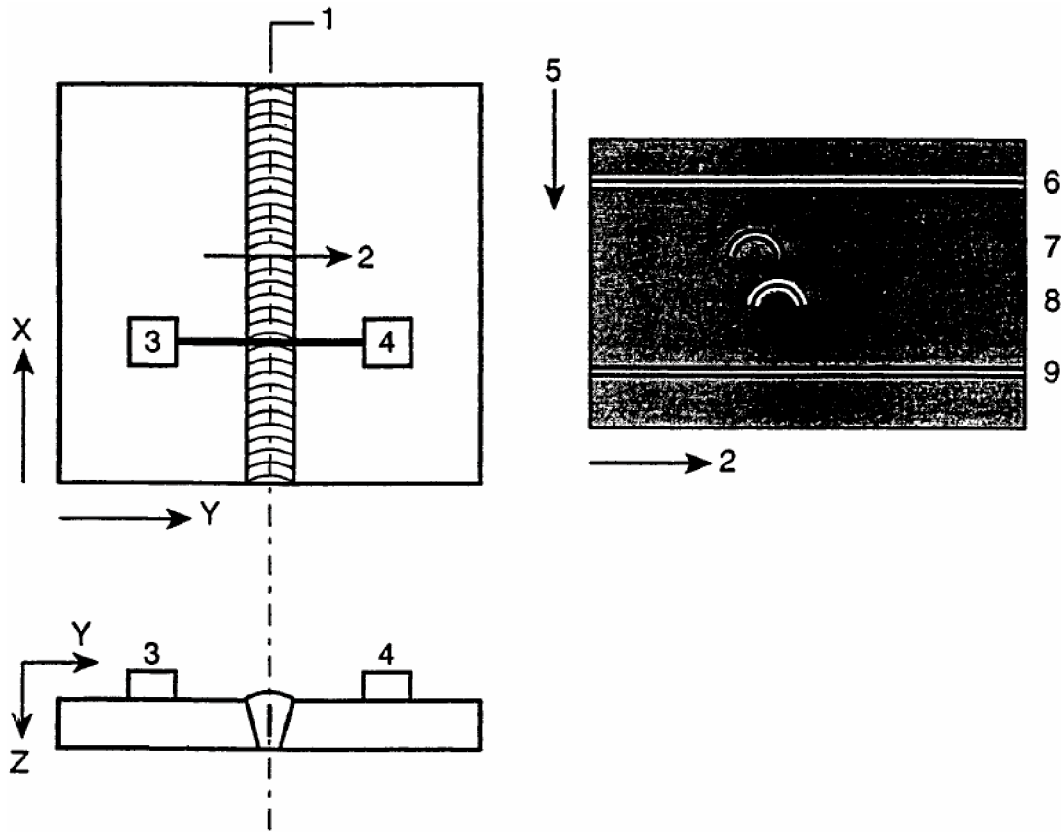

Key

- | | | | |
|---|---|---|-------------------------|
| 1 | reference line | 6 | lateral wave |
| 2 | direction of probe displacement (y-direction) | 7 | discontinuity upper tip |
| 3 | transmitter | 8 | discontinuity lower tip |
| 4 | receiver | 9 | back wall reflection |
| 5 | transit time (through wall extent) | | |

Figure 5 — Parallel scan, with the typical direction of probe displacement shown on the left and the corresponding B-scan shown on the right

The set-up procedure described in this subclause intends to ensure:

- sufficient system gain and signal-to-noise ratio to detect the diffracted signals of interest;
- acceptable resolution and adequate coverage of the region of interest;
- efficient use of the dynamic range of the system.

7.2 Probe choice and probe separation

7.2.1 Probe selection

In this clause typical probe arrangements are given for TOFD in order to achieve good detection capabilities on both thin and thick specimens. Note that these arrangements are not mandatory and that the exact requirements to achieve a specification should be checked.

For steel thicknesses up to 70 mm, a single pair of probes can be used. The recommended probe selection parameters to achieve sufficient resolution and adequate coverage are shown in Table 1 for three different ranges of wall thicknesses.

Table 1 — Recommended probe selection parameters for steel thicknesses up to 70 mm

Wall thickness mm	Centre frequency MHz	Transducer size mm	Nominal probe angle °
< 10	10 up to 15	2 up to 6	50 up to 70
10 up to < 30	5 up to 10	2 up to 6	50 up to 60
30 up to < 70	2 up to 5	6 up to 12	45 up to 60

For thicknesses greater than 70 mm, the wall thickness shall be divided into more than one inspection zone, each zone covering a different depth region. Table 2 shows the recommended centre frequencies, transducer sizes and nominal probe angles to achieve sufficient resolution and adequate coverage for thick materials from 70 mm up to 300 mm. These zones can be inspected simultaneously or separately.

Table 2 — Recommended probe selection parameters for steel thicknesses from 70 mm up to 300 mm

Depth region mm	Centre frequency MHz	Transducer size mm	Nominal probe angle °
0 up to < 30	5 up to 10	2 up to 6	50 up to 70
30 up to < 100	2 up to 5	6 up to 12	45 up to 60
100 up to ≤ 300	1 up to 3	10 up to 25	45 up to 60

7.2.2 Probe separation

The maximum diffraction efficiency occurs when the included angle is about 120°. The probes should be arranged such that the (imagined) beam centre lines intersect at about this angle in the depth region where discontinuities are anticipated/sought.

Deviations of more than -35° or $+45^\circ$ from this value may cause the diffracted echoes to be weak and should not be used unless detection capabilities can be demonstrated.

7.3 Time window setting

Ideally, the time window recorded should start at least 1 μ s prior to the time of arrival of the lateral wave, and should at least extend up to the first back wall echo. Because mode converted echoes can be of use in identifying defects, it is recommended that the time window recorded also includes the time of arrival of the first mode-converted back wall echo signal.

As a minimum requirement, the time window recorded shall at least cover the depth region of interest, as shown e.g. in Tables 1 and 2.

Where a smaller time window is appropriate (e.g. to improve sizing accuracy), it will be necessary to demonstrate that discontinuity detection capabilities are not impaired, for instance by using representative flaws or diffracting artificial defects in a reference block as described in Annex A.

7.4 Sensitivity setting

The probe separation and the time window shall be set to those values that will be used in the subsequent inspection.

The aim is to make sure that the signals from discontinuities are within the range of the digitizer and that the limiting noise is acoustic rather than electronic.

The equipment settings (electronic noise suppression and system gain) are to be adjusted such that the electronic noise prior to the arrival of the lateral wave indication is at least 6 dB lower in amplitude than within the region of the time-base after the arrival of the lateral wave. The latter should be set to approximately 5 % of the amplitude scale.

The sensitivity setting can now be checked making use of representative flaws or diffracting artificial defects in a reference block as described in Annex A. The results can be used to justify reducing the gain setting or give warning that the signal-to-noise ratio is insufficient.

7.5 Scan resolution setting

It is recommended to record one A-scan per millimetre of probe displacement. CEN/TS 14751 gives minimum densities depending on material thickness.

7.6 Setting of scanning speed

Scanning speed shall be selected such that it is compatible with the requirements of 7.3, 7.4 and 7.5.

7.7 Checking system performance

It is recommended that system performance is checked before and after an inspection by recording and comparing a limited number of representative A-scans. See also EN 12668-3.

8 Interpretation and analysis of data

8.1 Basic analysis of discontinuities

8.1.1 General

Reporting or acceptance criteria shall be agreed upon by contracting parties prior to inspection. Reporting or acceptance criteria shall be written in a specification prior to inspection.

Discontinuities detected by TOFD shall be characterized by at least their:

- position in the object (x- and y- coordinates);
- length (Δx);
- depth and height (z, Δz);
- type, limited to 'top-surface breaking', 'bottom-surface breaking' or 'embedded'.

8.1.2 Characterisation of discontinuities

8.1.2.1 General

In order to characterise a discontinuity, the phase of the tip-diffraction associated with this discontinuity shall be determined:

- signal with same apparent phase as the lateral wave shall be considered to originate from the lower tip of a discontinuity;
- signal with the same apparent phase as the back wall echo shall be considered to originate either from an upper tip of a discontinuity or from a discontinuity with no measurable height.

If the signal-to-noise ratio is insufficient to allow the phase of the signal to be detected, these identifications are invalid.

8.1.2.2 Top-surface breaking discontinuities

An indication consisting of a lower-tip diffraction with an associated weakening (check for couplant loss) or interruption of the lateral wave shall be considered a top-surface breaking discontinuity.

Sometimes a slight shift of the lateral wave towards longer time-of-flight can be observed.

8.1.2.3 Bottom-surface breaking discontinuities

An indication consisting of an upper-tip diffraction with either an associated shift of the back wall echo towards longer time-of-flight or an interruption (check for couplant loss) of the back wall echo shall be considered a bottom-surface breaking discontinuity.

8.1.2.4 Embedded discontinuities

An indication consisting of both an upper-tip and a lower-tip diffraction shall be considered an embedded discontinuity.

An indication consisting solely of an apparent upper-tip diffraction with no associated indications in either lateral wave or back wall echo shall be considered a discontinuity with no height. Care must be taken however, because the indications in the lateral wave or back wall echo can be very weak, resulting in misinterpretation of the discontinuity. In case of doubt appropriate action shall be taken, either by performing multiple TOFD-scans (see 8.2.1) or by applying other techniques.

In case further characterisation is required, reference shall be made to 8.2.

In case of doubt about the interpretation of a discontinuity, the worst possible interpretation shall be retained, until the interpretation can be verified.

8.1.3 Estimation of discontinuity position

In general it will be sufficiently accurate to assume that the discontinuity is located on the intersection between the xz -plane mid-way between the two ultrasonic probes and the yz -plane through the centre-lines of the two probes.

The time-of-flight of an indication generated by a discontinuity can also be used to estimate its position. The surface of constant time-of-flight theoretically is an ellipsoid centred around the index points of the ultrasonic probes. The exact determination of the position of the diffractor can only be achieved by at least two scans (see 8.2.1).

If a more accurate assessment of the position and/or orientation of the discontinuity is required, multiple TOFD-scans (non-parallel and/or parallel) will have to be performed.

8.1.4 Estimation of discontinuity length

The estimation of the length of a discontinuity shall be made directly from the probe displacement of a non-parallel scan. In common with all ultrasonic techniques this record is likely to be elongated because of the finite width of the ultrasonic beam, resulting in conservative estimates of the discontinuity length.

Indications with an apparent length of less than 1,5 times the size of the probe transducer used are too small to be sized, in length, by normal TOFD procedures but see 8.2.3 for additional algorithms to determine discontinuity length.

8.1.5 Estimation of discontinuity depth and height

It is assumed that the ultrasonic energy enters and leaves the specimen at the index points of the probes. In case the discontinuity is assumed to be mid-way between the two probes (see 8.1.3), the depth of the defect is given by:

$$d = \left[1/4(ct)^2 - S^2 \right]^{1/2} \quad (1)$$

where

- c sound velocity;
- t time-of-flight of the tip-diffraction signal;
- d depth of the tip of the discontinuity;
- S half the distance between the index points of the ultrasonic probes.

The time-of-flight of the ultrasonic signal inside the ultrasonic probes shall be subtracted before the calculation of the depth is made. Failure to do so will result in grave errors in the calculated depth.

To avoid the errors that may arise from probe delay estimation the depth d shall be calculated, if possible, from the time-of-flight differences, Δt , between the lateral wave and the diffracted pulse. Hence:

$$d = 1/2 \left[(c\Delta t)^2 + 4c\Delta tS \right]^{1/2} \quad (2)$$

8.1.5.1 Top-surface breaking discontinuities

The height of a top-surface breaking imperfection is determined by the distance between the top surface and the depth of the lower-tip diffraction signal.

8.1.5.2 Bottom-surface breaking discontinuities

The height of a bottom-surface breaking discontinuity is determined by the difference in depth between the upper-tip diffraction and the bottom surface.

8.1.5.3 Embedded discontinuity

The height of an embedded discontinuity is determined by the difference in depth between the upper-tip and lower-tip diffraction.

8.2 Detailed analysis of discontinuities

8.2.1 General

Detailed analysis of discontinuities can be performed only on discontinuities already detected by basic TOFD-scans. In addition, the application of other NDT-techniques can be considered in order to arrive at a more detailed characterisation.

The motivation for detailed discontinuity analysis can be:

- more accurate assessment of discontinuity length, depth and height;
- assessment of discontinuity orientation;
- detailed estimation of discontinuity type.

The detailed analysis of discontinuities involves performing additional scans with different probe angles, frequencies and/or probe separation. Also parallel scans can be performed. The detailed analysis can also involve the application of additional computer algorithms to analyse the data.

8.2.2 Additional scans

8.2.2.1 Scans with lower test frequency

Scans with lower test frequencies can be performed if the signal-to-noise ratio is too low to permit detailed discontinuity analysis even with considerable averaging. In general, this will be at the expense of an increased dead zone and a decreased resolution.

The equipment set-up parameters shall be optimised (see Clauses 6 and 7).

8.2.2.2 Scans with higher test frequency

Scans with higher test frequencies can be performed to obtain increased resolution, increased sizing accuracy and a reduced dead zone, at the expense of a reduced signal-to-noise ratio, due to increased grain noise. The equipment set-up parameters shall be optimised (see Clauses 6 and 7).

8.2.2.3 Scans with reduced probe angle

Scans with a reduced probe angle and an associated decreased probe centre separation can be performed to obtain increased resolution, increased sizing accuracy and a reduced dead zone at the expense of a smaller insonified volume of the specimen. The equipment set-up parameters shall be optimised (see Clauses 6 and 7).

8.2.2.4 Scans with different probe offset

In order to obtain the lateral position of the discontinuity (y -direction) and/or its orientation, either a parallel scan or an additional non-parallel scan with different probe distance (offset) can be made. The equipment set-up parameters shall be optimised (see Clauses 6 and 7).

It shall be checked that the phase relationship of the signals observed in these scans is identical to the phase relationship in the initial scans.

The surface of constant time-of-flight for a tip-diffraction signal (locus curve) is an ellipsoid. If we consider only the yz -plane through the probes, the ellipse describing a constant path is expressed by:

$$ct = \left[d^2 + (S - y)^2 \right]^{1/2} + \left[d^2 + (S + y)^2 \right]^{1/2} \quad (3)$$

From this equation it is clear that a different offset of the diffractor from the centre plane between the probes (i.e. a different y -value) will result in a different time-of-flight of the tip-diffraction. Therefore the apparent depth of the discontinuity tip will change in scans with different probe positions.

The lateral position of a discontinuity tip (y -direction) can be determined directly from a parallel scan by the position of minimum apparent depth. A number of adjacent parallel scans at different x -coordinates will be required to find the position of real minimal depth of the discontinuity.

Once the position and depth of both tips of a discontinuity are known, its orientation can be determined from the axis through the two tips of the discontinuity.

In principle, two non-parallel scans, offset with respect to each other, also suffice for the accurate determination of discontinuity depth, length and orientation, provided that the overlap of the insonified volumes is sufficient.

However, the determination of the position of the discontinuity tip from two non-parallel scans is less straightforward and will involve the drawing of locus curves by additional software (see 8.2.3).

Additional parallel scans may also be used to detect near-surface discontinuities that are poorly resolved because of the proximity of the lateral wave or the back wall echo. The apparent depth of the discontinuity will change in each scan and this will enable resolving it from the lateral wave or the back wall echo.

8.2.3 Additional algorithms

Computer algorithms can be useful in analysing the data recorded in a TOFD-scan.

For example:

- curve fitting overlays for accurate determination of discontinuity length (see also 8.1.4);
- subtraction of lateral wave and/or back wall echo in order to detect indications otherwise obscured due to interference (see 10.2). If the surface is rough or pitted, the effectiveness of this technique should be demonstrated in trials;
- linearisation algorithms to linearise complete B-scans to accurately determine the depth or the height of the discontinuity;
- modelling algorithms enabling the drawing of locus curves and the analysis of mode converted signals. This can provide additional insight in the position, depth and orientation of the discontinuity. Detailed understanding of the physics and modelling software are required.

The algorithms to be used in analysing the data shall be written in a specification and shall be agreed upon by the contracting parties prior to inspection.

9 Detection and sizing in complex geometries

For class 2 objects, if the surface between the two probes is flat, no further restrictions apply.

Otherwise for class 2 objects and for all class 3 objects, a modified inspection and interpretation procedure will be required to allow for the curvature of the object.

For class 4 and 5 objects special data processing techniques and operating conditions will apply.

Computer algorithms will be useful in analysing the data in these cases.

To confirm discontinuity detection capabilities, the use of representative test specimens with natural flaws or artificial defects is strongly recommended in these cases as well.

10 Limitations of the technique

10.1 General

This clause considers the limitations of the TOFD technique and is equally applicable to basic TOFD-detection as well as to TOFD-sizing. The limits of achievable accuracy under normal conditions are defined and the influence of dead zones, which can affect detectability, is discussed. It is important to realize that the overall reliability of the technique is determined by a large number of contributing factors and the overall error will not be less than the combined errors discussed in this clause.

Discontinuities which are highly tilted or skewed, such as transverse cracks in non-parallel scans, are likely to be more difficult to detect and it is recommended that specific demonstrations of capability are carried out in such cases. In addition, discontinuities which are not serious, such as point like discontinuities, have some ability to mimic more serious discontinuities such as cracks. Once again it is recommended that the ability to distinguish small cracks is demonstrated, where appropriate. Demonstrations of capability can be specific to the inspection or can be referred back to other documented data.

10.2 Accuracy and resolution

10.2.1 General

A distinction should be made between accuracy and resolution. Accuracy is the degree to which the position of a reflector or diffractor can be determined, whereas resolution defines the degree to which closely spaced diffractors can be distinguished from one another.

The accuracy of a TOFD-measurement will be influenced by timing errors, errors in the sound velocity, probe centre separation errors and errors in the assumed lateral position of an indication. Under normal circumstances the overall accuracy will be dominated by errors in the assumed lateral position of an indication.

10.2.2 Errors in the lateral position

As stated in 8.1.3, the lateral position of an indication is normally assumed to be mid-way between the two probes. In reality, the indication will be located on an ellipse (Equation (3)). The error in depth (δd) due to the error in lateral position (δy) can be calculated by:

$$\delta d = (c^2 t^2 - 4S^2)^{1/2} (\delta y^2 / c^2 t^2) / 2 [(0,25 - \delta y^2 / c^2 t^2)]^{1/2} \quad (4)$$

In principle, the lower edge of the ultrasonic beams determines δy . If no reliable information on the lower beam edge is available, $\delta y = S$ shall be used.

10.2.3 Timing errors

The limit of accuracy in the depth of an indication, due to timing errors (δt), can be estimated from:

$$\delta d = c \delta t [d^2 + S^2]^{1/2} / 2d \quad (5)$$

where

δd error in d .

The timing error can be reduced by using a shorter pulse and/or a higher frequency.

10.2.4 Errors in sound velocity

The limit of accuracy in the estimate of the depth of an indication, due to errors in the sound velocity (δc), is given by:

$$\delta d = \delta c \left[d^2 + S^2 - S(d^2 + S^2)^{1/2} \right] / cd \quad (6)$$

This error is reduced if the probe centre separation is reduced. Independent calibration of the velocity by measurement of the delay of the back wall echo, with a known wall thickness, greatly reduces this error.

10.2.5 Errors in probe centre separation

Errors in half the distance between the index points (δS) will result in errors in depth measurement. The error in depth δd can be calculated by:

$$\delta d = \delta S \left[(d^2 + S^2)^{1/2} - S \right] / d \quad (7)$$

It should be noted that errors in probe centre separation can arise from both measurement errors in the distance between the probes, as well as errors in the index point calibration.

When the probe centre separation is smaller than twice the specimen thickness, the index point can no longer be considered a fixed point, but it becomes a function of depth. In this case, if accurate sizing is required, the depth measurement shall be calibrated with the aid of a representative test specimen.

10.2.6 Spatial resolution

The spatial resolution (R) is a function of depth and can be calculated by:

$$R = \left[c^2 (t_d + t_p)^2 / 4 - S^2 \right]^{1/2} - d \quad (8)$$

where

t_p duration of the ultrasonic pulse; and

t_d time-of-flight at depth d .

The resolution increases with increasing depth, and can be improved by decreasing the probe centre separation or the pulse length.

10.3 Dead zones

Near the scanning surface there is a dead zone (D_{ds}) due to presence of the lateral wave. Interference between the lateral wave and the discontinuity indication can obscure the indication. The depth of the so-called scanning-surface dead zone is given by:

$$D_{ds} = \left[c^2 t_p^2 / 4 + S c t_p \right]^{1/2} \quad (9)$$

Near the back wall there is also a dead zone (D_{dw}) due to presence of the back wall echo. The depth of the back wall dead zone is given by:

$$D_{dw} = \left[c^2 (t_W + t_p)^2 / 4 - S^2 \right]^{1/2} - W \quad (10)$$

where

t_W time-of-flight of the back wall echo; and

W wall thickness.

Both dead zones can be reduced by decreasing the probe centre separation or by using probes with shorter pulse duration.

11 TOFD examination without data recording

In manually applied TOFD, where interpretation is obtained directly from the A-scan, unrectified display of the signals shall be used.

This form of the TOFD technique should only be used on product classes with simple geometries, and the equipment set-up shall comply with the requirements of 7.2, 7.3 and 7.4.

In general it will not be possible to perform the detailed investigation of any response that is possible with recorded data. It will be more difficult to detect phase changes, slight changes in transit time and echoes close to the lateral wave.

12 Test procedure

TOFD test procedures shall comply with the requirements given in EN 583-1, as applicable.

Specific conditions of application and use of the TOFD technique will depend on the type of product examined and specific requirements, and shall be described in written procedures.

13 Test report

TOFD test reports shall comply with the requirements given in EN 583-1, as applicable.

In addition, TOFD examination reports shall contain the following information:

- description of the test specimen or reference block, if a test specimen or reference block has been used;
- probe type, frequency, angle(s), separation and position with respect to a reference line (e.g. weld centre line);
- plotted images (hard copies) of at least those locations where relevant indications have been detected. Details of equipment settings and method of setting test sensitivity.

Furthermore, all raw data recorded during the examination, stored on a magnetic or optical storage medium such as hard disk, tape or optical disk shall be kept for later reference.

Annex A (normative)

Reference blocks

The purpose of reference blocks is to set the system sensitivity correctly and to establish sufficient volumetric coverage.

The minimum requirements of a reference block are the following:

- it should be made of similar material as the object under inspection (e.g. with regard to sound velocity, grain noise and surface condition);
- wall thickness shall be equal to or greater than the nominal wall thickness of the object under inspection;
- width and the length of the scanning surface shall be adequate for probe movement over the reference diffractors.

Measurements shall be based on the diffracted signals from reference diffractors. These are either:

- machined notches, open to the scanning surface of the reference block; or
- side drilled holes with a diameter of at least twice the wavelength of the nominal frequency of the probes utilised in the inspection. The holes should be cut to the scanning surface in order to block the direct reflection from the top of the hole, see Figure A.1.

Reference diffractors should be present at approximately 10 %, 25 %, 50 %, 75 % and 90 % of the nominal thickness of the object under inspection.

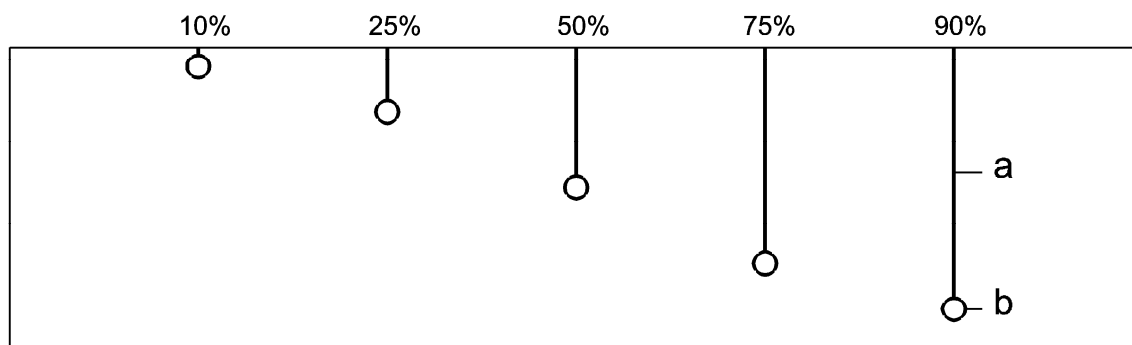

Key

- a saw cut
b side drilled hole

Figure A.1 — Sketch of a reference block, using side drilled holes as reference diffractors, connected to the scanning surface by means of a saw cut

Bibliography

- [1] CEN/TS 14751, *Welding — Use of time-of-flight diffraction technique (TOFD) for examination of welds*
- [2] prEN 15617, *Non-destructive testing of welds — Time-of-flight diffraction technique (TOFD) — Acceptance levels*

BSI - British Standards Institution

BSI is the independent national body responsible for preparing British Standards. It presents the UK view on standards in Europe and at the international level. It is incorporated by Royal Charter.

Revisions

British Standards are updated by amendment or revision. Users of British Standards should make sure that they possess the latest amendments or editions.

It is the constant aim of BSI to improve the quality of our products and services. We would be grateful if anyone finding an inaccuracy or ambiguity while using this British Standard would inform the Secretary of the technical committee responsible, the identity of which can be found on the inside front cover. Tel: +44 (0)20 8996 9000. Fax: +44 (0)20 8996 7400.

BSI offers members an individual updating service called PLUS which ensures that subscribers automatically receive the latest editions of standards.

Buying standards

Orders for all BSI, international and foreign standards publications should be addressed to Customer Services. Tel: +44 (0)20 8996 9001. Fax: +44 (0)20 8996 7001 Email: orders@bsigroup.com You may also buy directly using a debit/credit card from the BSI Shop on the Website <http://www.bsigroup.com/shop>

In response to orders for international standards, it is BSI policy to supply the BSI implementation of those that have been published as British Standards, unless otherwise requested.

Information on standards

BSI provides a wide range of information on national, European and international standards through its Library and its Technical Help to Exporters Service. Various BSI electronic information services are also available which give details on all its products and services. Contact Information Centre. Tel: +44 (0)20 8996 7111 Fax: +44 (0)20 8996 7048 Email: info@bsigroup.com

Subscribing members of BSI are kept up to date with standards developments and receive substantial discounts on the purchase price of standards. For details of these and other benefits contact Membership Administration. Tel: +44 (0)20 8996 7002 Fax: +44 (0)20 8996 7001 Email: membership@bsigroup.com

Information regarding online access to British Standards via British Standards Online can be found at <http://www.bsigroup.com/BSOL>

Further information about BSI is available on the BSI website at <http://www.bsigroup.com>.

Copyright

Copyright subsists in all BSI publications. BSI also holds the copyright, in the UK, of the publications of the international standardization bodies. Except as permitted under the Copyright, Designs and Patents Act 1988 no extract may be reproduced, stored in a retrieval system or transmitted in any form or by any means – electronic, photocopying, recording or otherwise – without prior written permission from BSI.

This does not preclude the free use, in the course of implementing the standard, of necessary details such as symbols, and size, type or grade designations. If these details are to be used for any other purpose than implementation then the prior written permission of BSI must be obtained.

Details and advice can be obtained from the Copyright and Licensing Manager. Tel: +44 (0)20 8996 7070 Email: copyright@bsigroup.com