

Mobile road construction machinery — Safety —

Part 6: Specific requirements for paver-finishers

ICS 93.080.10

National foreword

This British Standard is the UK implementation of EN 500-6:2006+A1:2008. It supersedes BS EN 500-6:2006, which is withdrawn.

The start and finish of text introduced or altered by amendment is indicated in the text by tags. Tags indicating changes to CEN text carry the number of the CEN amendment. For example, text altered by CEN amendment A1 is indicated by **A1** ~~A1~~.

The UK participation in its preparation was entrusted by Technical Committee B/513, Construction equipment and plant and site safety, to Subcommittee B/513/1, Earth moving machinery (International).

A list of organizations represented on this subcommittee can be obtained on request to its secretary.

This publication does not purport to include all the necessary provisions of a contract. Users are responsible for its correct application.

Compliance with a British Standard cannot confer immunity from legal obligations.

This British Standard was published under the authority of the Standards Policy and Strategy Committee on 30 November 2006

© BSI 2009

ISBN 978 0 580 62489 6

Amendments/corrigenda issued since publication

Comments	Date
30 September 2009	Implementation of CEN amendment A1:2008

EUROPEAN STANDARD

EN 500-6:2006+A1

NORME EUROPÉENNE

EUROPÄISCHE NORM

October 2008

ICS 93.080.10

Supersedes EN 500-6:2006

English Version

Mobile road construction machinery - Safety - Part 6: Specific requirements for paver-finishers

Machines mobiles pour la construction de routes - Sécurité
- Partie 6: Prescriptions spécifiques pour finisseurs

Bewegliche Straßenbaumaschinen - Sicherheit - Teil 6:
Besondere Anforderungen an Straßenfertiger

This European Standard was approved by CEN on 17 August 2006 and includes Amendment 1 approved by CEN on 25 August 2008.

CEN members are bound to comply with the CEN/CENELEC Internal Regulations which stipulate the conditions for giving this European Standard the status of a national standard without any alteration. Up-to-date lists and bibliographical references concerning such national standards may be obtained on application to the CEN Management Centre or to any CEN member.

This European Standard exists in three official versions (English, French, German). A version in any other language made by translation under the responsibility of a CEN member into its own language and notified to the CEN Management Centre has the same status as the official versions.

CEN members are the national standards bodies of Austria, Belgium, Bulgaria, Cyprus, Czech Republic, Denmark, Estonia, Finland, France, Germany, Greece, Hungary, Iceland, Ireland, Italy, Latvia, Lithuania, Luxembourg, Malta, Netherlands, Norway, Poland, Portugal, Romania, Slovakia, Slovenia, Spain, Sweden, Switzerland and United Kingdom.



EUROPEAN COMMITTEE FOR STANDARDIZATION
COMITÉ EUROPÉEN DE NORMALISATION
EUROPÄISCHES KOMITEE FÜR NORMUNG

Management Centre: rue de Stassart, 36 B-1050 Brussels

Contents

Page

Foreword.....	4
Introduction	5
1 Scope	6
2 Normative references	6
3 Terms and definitions	6
4 List of significant hazards	7
5 Safety requirements and/or protective measures	7
5.1 Lighting, signalling and marking lights and reflex-reflector devices.....	7
5.2 Operation and handling	7
5.3 Operator's station	7
5.4 Operator's seat.....	7
5.5 Controls and indicators	7
5.6 Starting	7
5.7 Stopping	8
5.8 Access systems to operator's station and to maintenance points	8
5.9 Protection	8
5.10 Pressurised systems	8
5.11 Fire protection.....	8
5.12 Hot surfaces	8
5.13 Signal devices and warning signs	8
5.14 Liquid gas units	8
5.15 Electrical and electronic systems	9
5.16 Electro-magnetic compatibility (EMC).....	9
5.17 Noise and vibration.....	9
5.18 Conveyors	9
6 Verification of safety requirements and/or protective measures	9
7 Information for the user	9
7.1 Warning signals and devices	9
7.2 Instruction handbook	9
7.3 Marking	9
Annex A (normative) Braking systems of rubber-tyred paver-finishers – Performance requirements and test procedures	10
Annex B (normative) Noise test code for paver-finishers	12
Annex C (normative) Noise test code for slipform pavers	17
Annex D (informative) Examples of paver-finishers	22
Annex ZA (informative) Relationship between this European Standard and the Essential Requirements of EC Directive 98/37/EC	27
Annex ZB (informative) [A1] Relationship between this European Standard and the Essential Requirements of EU Directive 2006/42/EC [A1]	28
Bibliography	29

Figures

Figure B.1	13
Figure B.2	13
Figure B.3 — Microphone positions	13
Figure C.1	17
Figure C.2	17
Figure C.3 — Microphone positions	18
Figure D.2 — Crawler-mounted paver-finisher	23
Figure D.3 — Pre-compaction screed.....	23
Figure D.4 — Compaction screed with vibration	24
Figure D.5 — Compaction screed with tamper bar	24
Figure D.6 — High-compaction screed with tamper bar and vibration.....	25
Figure D.7 — High-compaction screed with tamper bar, vibration and two pressure bars	25
Figure D.8 — Slipform paver with offset mould	26
Figure D.9 — Slipform paver with road mould	26

Tables

Table 1.....	7
Table B.1 — Settings for simulation to determine noise emission of a paver-finisher while paving	15
Table C.1 — Settings for simulation to determine noise emission of a slipform paver while paving.....	19

Foreword

This document (EN 500-6:2006+A1:2008) has been prepared by Technical Committee CEN/TC 151 "Construction equipment and building material machines — Safety", the secretariat of which is held by DIN.

This European Standard shall be given the status of a national standard, either by publication of an identical text or by endorsement, at the latest by April 2009, and conflicting national standards shall be withdrawn at the latest by December 2009.

This document includes Amendment 1, approved by CEN on 2008-08-25.

This document supersedes A1 EN 500-6:2006 A1.

The start and finish of text introduced or altered by amendment is indicated in the text by tags A1 A1.

This document has been prepared under a mandate given to CEN by the European Commission and the European Free Trade Association, and supports essential requirements of EU Directive(s).

A1 For relationship with EU Directive(s), see informative Annexes ZA and ZB, which are integral parts of this document. A1

EN 500 "Mobile road construction machinery — Safety" comprises the following parts:

- Part 1: Common requirements;
- Part 2: Specific requirements for road-milling machines;
- Part 3: Specific requirements for soil-stabilising machines and recycling machines;
- Part 4: Specific requirements for compaction machines;
- Part 6: Specific requirements for paver-finishers.

According to the CEN/CENELEC Internal Regulations, the national standards organizations of the following countries are bound to implement this European Standard: Austria, Belgium, Bulgaria, Cyprus, Czech Republic, Denmark, Estonia, Finland, France, Germany, Greece, Hungary, Iceland, Ireland, Italy, Latvia, Lithuania, Luxembourg, Malta, Netherlands, Norway, Poland, Portugal, Romania, Slovakia, Slovenia, Spain, Sweden, Switzerland and United Kingdom.

Introduction

This European Standard is a type C standard as stated in EN ISO 12100-1.

The machinery concerned and the extent to which hazards, hazardous situations and events are covered are indicated in the scope of this European Standard.

When provisions of this type C standard are different from those which are stated in type A or B standards, the provisions of this type C standard take precedence over the provisions of the other standards for machines that have been designed and built according to the provisions of this type C standard.

1 Scope

This part of EN 500 specifies the safety requirements for paver-finishers as defined in Clause 3 and deals with the significant hazards relevant to these machines, when they are used as intended and under conditions of misuse which are reasonably foreseeable. This part of EN 500 contains additional requirements to EN 500-1 “Common requirements”.

If internal and/or external vibrators are used for concrete paving, then prEN 12649 applies.

2 Normative references

The following referenced documents are indispensable for the application of this document. For dated references, only the edition cited applies. For undated references, the latest edition of the referenced document (including any amendments) applies.

EN 500-1:2006, *Mobile road construction machinery — Safety — Part 1: Common requirements*.

EN 953:1997, *Safety of machinery — Guards — General requirements for the design and construction of fixed and movable guards*.

EN ISO 3450:1996, *Earth-moving machinery — Braking systems of rubber-tyred machines — Systems and performance requirements and test procedures (ISO 3450:1996)*.

EN ISO 3744:1995, *Acoustics — Determination of sound power levels of noise sources using sound pressure — Engineering method in an essentially free field over a reflecting plane (ISO 3744:1994)*.

EN ISO 11201:1995, *Acoustics — Noise emitted by machinery and equipment — Measurement of emission sound pressure levels at a work station and at other specified positions — Engineering method in an essentially free field over a reflecting plane (ISO 11201:1995)*.

EN ISO 12100-1:2003, *Safety of machinery — Basic concepts, general principles for design — Part 1: Basic terminology, methodology (ISO 12100-1:2003)*.

3 Terms and definitions

For the purposes of this document, the terms and definitions given in EN ISO 12100-1:2003 and the following apply.

3.1 paver-finisher

mobile self-propelled machine (either rubber-tyred or crawler-mounted) specifically designed to receive, convey, distribute, profile and compact paving material (see Figures D.1 and D.2)

3.1.1 pre-compaction screed paver-finisher

machine that compacts the construction material by the weight of the screed (pre-compacting system) (see Figure D.3)

3.1.2 compaction screed paver-finisher

machine fitted with, in addition to the pre-compacting system, a single additional compaction system which may consist of vibrators or tamper bars (see Figures D.4 and D.5)

3.1.3

high-compaction screed paver-finisher

machine fitted with, in addition to the pre-compacting system, at least two compaction systems which may consist of vibrators, tamper bars or pressure bars (see Figures D.6 and D.7)

3.2

slipform paver

machine on three or four crawlers intended to move and to guide a mould that extrudes pre-vibrated concrete to make either continuous works, such as borders, inserts, paving stones, or layers of continuous concrete (see Figures D.8 and D.9)

4 List of significant hazards

Annex F of EN 500-1:2006 applies with the following exception:

Table 1

5	Hazards generated by vibration
5.1	Hand-arm vibrations

5 Safety requirements and/or protective measures

5.1 Lighting, signalling and marking lights and reflex-reflector devices

5.2 of EN 500-1:2006 applies.

5.2 Operation and handling

5.3 of EN 500-1:2006 applies.

5.3 Operator's station

5.4 of EN 500-1:2006 applies with the following exception:

- 5.4.1 of EN 500-1:2006, fifth and sixth indent, applies only for forward measurement;
- 5.4.2 of EN 500-1:2006, first paragraph, does not apply for paver-finishers.

5.4 Operator's seat

5.5 of EN 500-1:2006 applies.

5.5 Controls and indicators

5.6 of EN 500-1:2006 applies with the following addition:

- the extending or closing of the telescopic screed shall not be induced simultaneously from both the operator's station and the remote control area. Controls for the regulation of the telescopic screeds shall be designed in such a manner as to ensure that they return to neutral when released (hold-to-run control).

5.6 Starting

5.7 of EN 500-1:2006 applies.

5.7 Stopping

5.8 of EN 500-1:2006 applies with the following addition:

- braking systems of rubber-tyred paver-finishers shall comply with Annex A.

5.8 Access systems to operator's station and to maintenance points

5.9 of EN 500-1:2006 applies with the following exception and addition:

- the height of the first step (600 mm) for access to the operator's position can be exceeded in transport position.

5.9 does not apply for access systems leading to service points in the area of the material hopper.

Walkways shall be fitted to the screed sections and shall cover the operating width of the screed.

5.9 Protection

5.10 of EN 500-1:2006 applies with the following addition:

- screeds shall be provided with a locking device to ensure safe elevation.

The spreader augers from which mechanical hazard emanates within the width of the basic machine shall be fitted with fixed guards according to 3.2 of EN 953:1997, e.g. by gratings.

When the spreader augers extend beyond the width of the basic machine, they shall at least be protected by guard-rails.

When paver-finishers are designed for use on rails, all wheels in each direction of travel shall be provided with foot-guards. The distance between the foot-guards and upper edge of the rail shall not exceed 20 mm.

5.10 Pressurised systems

5.11 of EN 500-1:2006 applies.

5.11 Fire protection

5.12 of EN 500-1:2006 applies.

5.12 Hot surfaces

5.13 of EN 500-1:2006 applies.

5.13 Signal devices and warning signs

5.14 of EN 500-1:2006 applies with the following addition:

- telescopic screeds used on paver-finishers which could form crushing or shearing zones during their operation shall be fitted with yellow flashing lights. Those flashing lights shall be located close to the crushing or shearing zones and shall be activated automatically when the screeds are extended or retracted.

5.14 Liquid gas units

5.15 of EN 500-1:2006 applies.

5.15 Electrical and electronic systems

5.16 of EN 500-1:2006 applies.

5.16 Electro-magnetic compatibility (EMC)

5.17 of EN 500-1:2006 applies with the following addition:

- the antenna shall be located successively on the left- and right-hand sides of the paver-finisher, with the antenna parallel to the plane of the longitudinal symmetry of the paver-finisher and in line with the SIP.

5.17 Noise and vibration

5.18.2 and 5.18.3 of EN 500-1:2006 apply with the following addition:

- for the determination of the A_{17} noise emission values A_{17} , Annex B applies to paver-finishers and Annex C applies to slipform pavers.

5.18 Conveyors

Hopper conveyors need not to comply with 5.19 of EN 500-1:2006.

6 Verification of safety requirements and/or protective measures

Clause 6 of EN 500-1:2006 applies.

7 Information for the user

7.1 Warning signals and devices

Annex E of EN 500-1:2006 applies.

7.2 Instruction handbook

7.2 of EN 500-1:2006 applies with the following additions:

- information for a safe cleaning of the hopper and auger;
- information for a safe handling of gas bottles.

7.3 Marking

7.3 of EN 500-1:2006 applies.

Annex A (normative)

Braking systems of rubber-tyred paver-finishers – Performance requirements and test procedures

A.1 Scope

This annex specifies the performance requirements and test procedures of brake systems for rubber-tyred paver-finishers.

The brake systems shall meet the requirements of EN ISO 3450 with the following additions and exceptions:

A.2 Machine mass

A.2.1 General

Clause 3 of EN ISO 3450:1996 applies with the following addition:

A.2.2 Operating mass

Operating mass in the heaviest version of the paver-finisher, including canopy or cabin with all their components and mountings and by considering all working elements to be fitted for the maximum working width approved by the manufacturer of the machine, including operator of 75 kg, half-full fuel tank and full lubricating system, hydraulic oil system and cooling system. If equipped, with half-full tanks for emulsion and emulsion solvent.

A.3 General requirements

A.3.1 General

Clause 5 of EN ISO 3450:1996 applies with the following addition:

A.3.2 Disconnection

If a device is fitted for disconnection, such as a clutch or a gearbox, then this shall only be operated at standstill.

The brake systems are permitted to be effective via gear components and chains and to possess only one braking surface for all wheels slowed down.

A.3.3 Service brake system

On machines with a hydrostatic traction drive developing a maximum speed of no more than 25 km/h, this hydrostatic traction drive can at the same time be used as a service brake. After standstill, an unintentional movement shall not be possible.

A.4 Test conditions

Clause 6 of EN ISO 3450:1996 applies with the following addition:

- use of the hydrostatic traction drive is admitted for tests of the brake system.

Annex B (normative)

Noise test code for paver-finishers

B.1 Scope

This noise test code specifies all the information necessary to carry out efficiently and under standardized conditions the determination, declaration and verification of the noise emission characteristics of paver-finishers.

Noise emission characteristics include emission sound pressure levels at workstations and the sound power level. The determination of those quantities is necessary for:

- manufacturers to declare the noise emitted;
- comparing the noise emitted by machines in the family concerned;
- purposes of noise control at the source at the design stage.

The use of this noise test code ensures reproducibility of the determination of the noise emission characteristics within specified limits determined by the grade of accuracy of the basic noise-measurement method used. Noise-measurement methods allowed by this standard are engineering methods (grade 2).

B.2 Determination of A-weighted sound power level

B.2.1 General

This annex specifies additional requirements for the determination of A-weighted sound power level according to EN ISO 3744.

B.2.2 Measurement surface

A hemispherical test area shall be used for measurement.

B.2.3 Size of the measurement surface

The radius shall be calculated from the basic length L of the machine (Figures B.1 and B.2). The basic length includes the main body of the machine plus working units, such as screed. The width of the machine shall be the basic width of the paver-finisher.

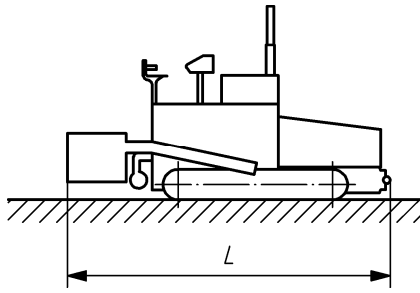

Figure B.1

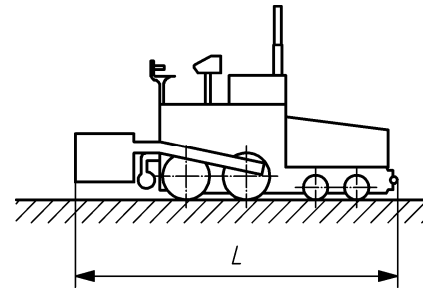

Figure B.2

The radius shall be:

- 4 m when the basic length L of the machine to be tested is less than or equal to 1,5 m;
- 10 m when the basic length L of the machine to be tested is greater than 1,5 m but less than or equal to 4 m;
- 16 m when the basic length L of the machine to be tested is greater than 4 m.

B.2.4 Microphone positions on the hemispherical measurement surface

Six microphone positions (i.e. positions 2, 4, 6, 8, 10 and 12) shall be arranged according to Figure B.3.

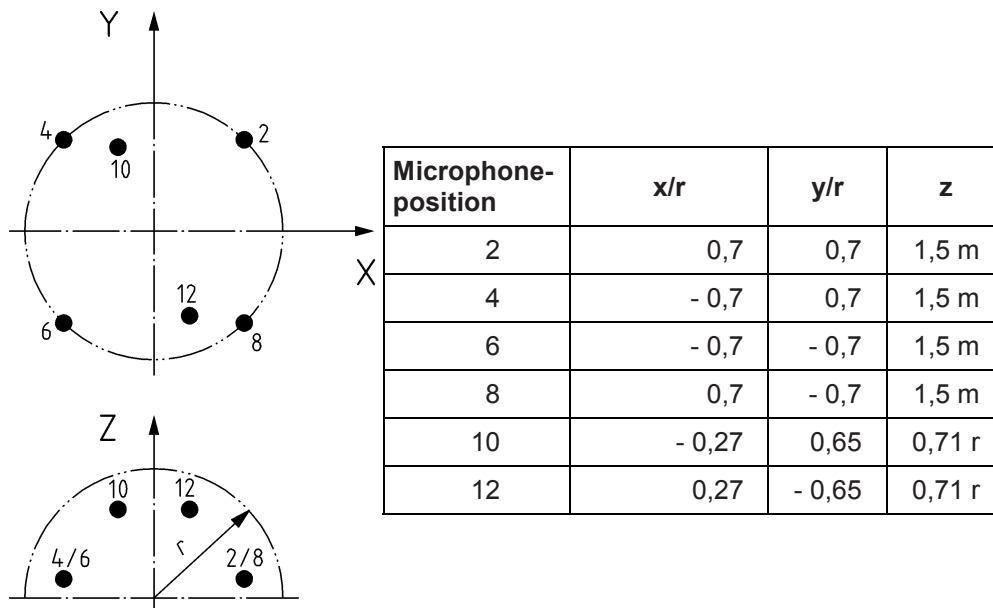

Figure B.3 — Microphone positions

B.2.5 Positioning of the machine

The centre of the machine shall coincide with the centre of the hemisphere, which is the intersecting point of the x -axis and y -axis (see Figure B.3). The front (direction of travelling) of the machine shall point towards the microphone positions 2 and 8. For positioning the machine, the middle of the basic length L shall be regarded as the central point.

B.2.6 Repetition of the test

The A-weighted sound power level shall be determined at least three times. If at least two of the determined values do not differ by more than 1 dB, further measurements will not be necessary. Otherwise the measurements shall be continued until 2 values differing by no more than 1 dB are obtained. The A-weighted sound power level to be used for calculating the sound power level to be declared is the arithmetic mean of both highest values that do not differ by more than 1 dB.

The total duration of each measurement at each microphone position shall be at least 15 s.

B.3 Determination of A-weighted emission sound pressure level at the operator's position

B.3.1 General

This annex specifies additional requirements for the determination of the A-weighted sound pressure level at the operator's station of paver-finishers according to EN ISO 11201 for a seating and/or standing operator. The operator shall be present during the test.

B.3.2 Enclosed operator's positions

When equipped with a cabin, all doors and windows shall be closed during measurement. Air-conditioning shall be set to mid-position.

B.3.3 Quantities to be determined

If more than one operator's station is provided, the emission sound pressure level at the operator's station is the highest emission value determined at the operator's stations.

B.3.4 Repetition of the test

The sound pressure level shall be measured at least three times at each microphone position. If at least two of the measured values do not differ by more than 1 dB, further measurements will not be necessary. Otherwise the measurements shall be continued until 2 values differing by no more than 1 dB are obtained. The A-weighted emission sound pressure level to be used is the arithmetic mean of the two highest values that do not differ by more than 1 dB.

The duration of each measurement at each microphone position shall be at least 15 s.

B.3.5 Microphone position(s)

Should more than one operator's position be provided, then measurement shall be carried out for all positions.

B.4 Operation conditions

The machine shall be equipped as determined by the manufacturer, i.e. that all working units such as conveying systems, spreading systems, compacting systems and screed shall be fitted.

The engine of the machine shall operate at the nominal speed indicated by the manufacturer. All working units shall be activated and operate at the speeds indicated in Table B.1.

The screed shall, across its basic width, be placed on a base made of cellular rubber (natural rubber basis) with a total thickness of at least 50 mm. Resonance effects should be avoided.

Table B.1 — Settings for simulation to determine noise emission of a paver-finisher while paving

Conveying system (speed)	at least 10 % of maximum value
Spreading system (revolutions)	at least 40 % of maximum value
Tamper (speed, stroke)	at least 50 % of maximum values
Vibrators (speed, unbalance moment)	at least 50 % of maximum values
Pressure bars (frequency, pressure)	at least 50 % of maximum values
NOTE Figures indicated in the table refer to paving.	

B.5 Uncertainty

The measurement uncertainty and, in the case of series machines, the uncertainty due to production variations shall be considered when determining the value of the A-weighted sound power level and that of the A-weighted emission sound pressure level.

Current experience shows that the total uncertainty (measurement plus production) of paver-finishers is less than $K_{WA} = 1,0$ dB for the A-weighted sound power levels and less than $K_{pA} = 2,0$ dB for the A-weighted emission sound pressure level.

K_A is the value of the total uncertainty for A-weighted levels associated with a measured noise emission value. It is expressed in decibels.

B.6 Information to be recorded

EN ISO 3744 and EN 11201 shall apply with the following additions:

- type and output of engine;
- engine speed;
- fan speed;
- values according to Table B.1;
- measurement duration t_M for each measurement;
- description of the test environment;
- A-weighted sound power level from each of the three measurements and the resulting sound power level as emission value;
- A-weighted sound pressure levels from each of the three measurements at the operator's position and the resulting emission sound pressure level;
- place, date of measurement, test laboratory and person responsible.

B.7 Information to be reported

EN ISO 3744 and EN 11201 shall apply with the following addition:

- type and output of engine;
- engine speed;
- fan speed;

- values according to Table B.1;
- measurement duration t_M for each measurement;
- description of the test environment;
- A-weighted sound power level from each of the three measurements and the resulting sound power level as emission value;
- A-weighted sound pressure levels from each of the three measurements at the operator's position and the resulting emission sound pressure level;
- place, date of measurement, test laboratory and person responsible.

The test report shall include the statement that the sound power level and the emission sound pressure level at the operator's position have been determined entirely in accordance with the specifications of this annex. The A-weighted sound power level of the machine under test and A-weighted emission sound pressure level at the operator's position shall be rounded down or up to the nearest integral value in dB (< 0,5 round down; \geq 0,5 round up).

B.8 Declaration and verification of noise emission values

The declared A-weighted sound power level shall be the sum of the measured value and the associated uncertainty K_{WA} (see B.5).

NOTE The declared value of the A-weighted sound power level is identical to the guaranteed sound power level according to 2000/14/EC.

The declared A-weighted emission sound pressure level shall be the sum of the measured value and the associated uncertainty K_{pA} (see B.5).

The noise declaration shall explicitly state that the noise emission values have been obtained according to this noise test code.

Any verification shall be done using this noise test code. If the value measured during verification is less than or equal to the declared value, the declared value is verified.

Annex C (normative)

Noise test code for slipform pavers

C.1 Scope

This noise test code specifies all the information necessary to carry out efficiently and under standardised conditions the determination, declaration and verification of the noise emission characteristics of slipform pavers.

Noise emission characteristics include emission sound pressure levels at workstations and the sound power level. The determination of those quantities is necessary for:

- manufacturers to declare the noise emitted;
- comparing the noise emitted by machines in the family concerned;
- purposes of noise control at the source at the design stage.

The use of this noise test code ensures reproducibility of the determination of the noise emission characteristics within specified limits determined by the grade of accuracy of the basic noise-measurement method used. Noise-measurement methods allowed by this standard are engineering methods (grade 2).

C.2 Determination of A-weighted sound power level

C.2.1 General

This annex specifies additional requirements for the determination of A-weighted sound power level according to EN ISO 3744.

C.2.2 Measurement surface

A hemispherical test area shall be used for measurement.

C.2.3 Size of the measurement surface

The radius shall be calculated from the basic length L of the machine (Figures C.1 and C.2). The basic length includes the main body of the machine plus working units, such as screed. The width of the machine shall be the basic width of the slipform paver.

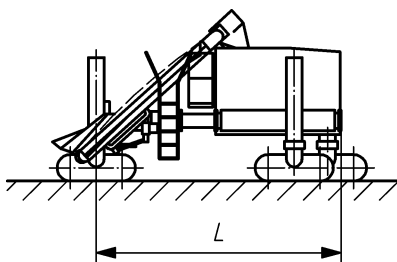

Figure C.1

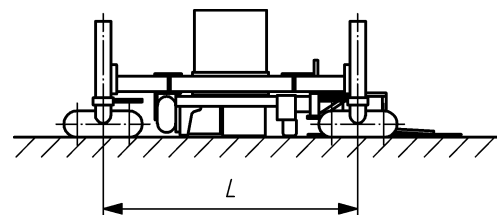

Figure C.2

The radius shall be:

- 4 m when the basic length L of the machine to be tested is less than or equal to 1,5 m;
- 10 m when the basic length L of the machine to be tested is greater than 1,5 m but less than or equal to 4 m;
- 16 m when the basic length L of the machine to be tested is greater than 4 m.

C.2.4 Microphone positions on the hemispherical measurement surface

Six microphone positions (i.e. positions 2, 4, 6, 8, 10 and 12) shall be arranged according to Figure C.3.

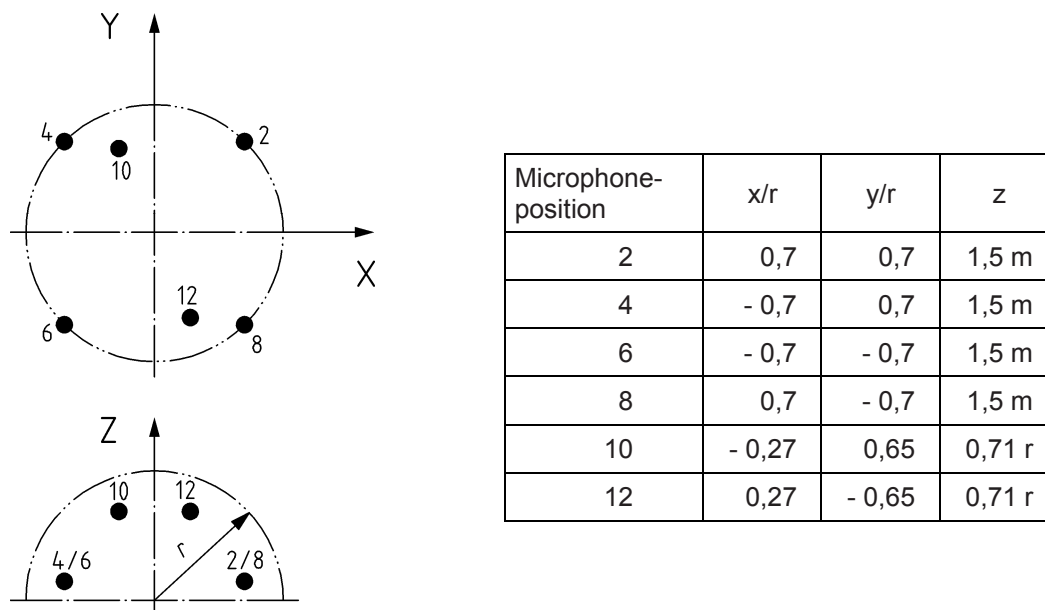

Figure C.3 — Microphone positions

C.2.5 Positioning of the machine

The centre of the machine shall coincide with the centre of the hemisphere, which is the intersecting point of the x -axis and y -axis (see Figure C.3). The front (direction of travelling) of the machine shall point towards the microphone positions 2 and 8. For positioning the machine, the middle of the basic length L shall be regarded as the central point.

C.2.6 Repetition of the test

The A-weighted sound power level shall be determined at least three times. If at least two of the determined values do not differ by more than 1 dB, further measurements will not be necessary. Otherwise the measurements shall be continued until 2 values differing by no more than 1 dB are obtained. The A-weighted sound power level to be used for calculating the sound power level to be declared is the arithmetic mean of both highest values that do not differ by more than 1 dB.

The total duration of each measurement at each microphone position shall be at least 15 s.

C.3 Determination of A-weighted emission sound pressure level at the operator's position

C.3.1 General

This annex specifies additional requirements for the determination of the A-weighted sound pressure level at the operator's station of slipform pavers according to EN ISO 11201 for a seating and/or standing operator. The operator shall be present during the test.

C.3.2 Enclosed operator's positions

When equipped with a cabin, all doors and windows shall be closed during measurement. Air-conditioning shall be set to mid-position.

C.3.3 Quantities to be determined

If more than one operator's station is provided, the emission sound pressure level at the operator's station is the highest emission value determined at the operator's stations.

C.3.4 Repetition of the test

The sound pressure level shall be measured at least three times at each microphone position. If at least two of the measured values do not differ by more than 1 dB, further measurements will not be necessary. Otherwise the measurements shall be continued until 2 values differing by no more than 1 dB are obtained. The A-weighted emission sound pressure level to be used is the arithmetic mean of the two highest values that do not differ by more than 1 dB.

The duration of each measurement at each microphone position shall be at least 15 s.

C.3.5 Microphone position(s)

Should more than one operator's position be provided, measurement shall be carried out for all positions.

C.4 Operation conditions

The machine shall be equipped as determined by the manufacturer, i.e. that all working units such as conveying systems, spreading systems, compacting systems and screed shall be fitted.

The engine of the machine shall operate at the nominal speed indicated by the manufacturer. All working units except inner and outer vibrators shall be activated and operate at the speeds indicated in Table C.1. If necessary, the sliding beam of the super smoother may be taken off.

Table C.1 — Settings for simulation to determine noise emission of a slipform paver while paving

Conveying system (speed)	at least 50 % of maximum value
Spreading system (speed)	at least 50 % of maximum value
Smoothing devices (frequency)	at least 50 % of maximum values
NOTE Figures indicated in the table refer to paving.	

C.5 Uncertainty

The measurement uncertainty and, in the case of series machines, the uncertainty due to production variations shall be considered when determining the value of the A-weighted sound power level and that of the A-weighted emission sound pressure level.

Current experience shows that the total uncertainty (measurement plus production) of slipform pavers is less than $K_{WA} = 1,0$ dB for the A-weighted sound power levels and less than $K_{pA} = 2,0$ dB for the A-weighted emission sound pressure level.

K_A is the value of the total uncertainty for A-weighted levels associated with a measured noise emission value. It is expressed in decibels.

C.6 Information to be recorded

EN ISO 3744 and EN 11201 shall apply with the following additions:

- type and output of engine;
- engine speed;
- fan speed;
- values according to Table C.1;
- measurement duration t_M for each measurement;
- description of the test environment;
- A-weighted sound power level from each of the three measurements and the resulting sound power level as emission value;
- A-weighted sound pressure levels from each of the three measurements at the operator's position and the resulting emission sound pressure level;
- place, date of measurement, test laboratory and person responsible.

C.7 Information to be reported

EN ISO 3744 and EN 11201 shall apply with the following additions:

- type and output of engine;
- engine speed;
- fan speed;
- values according to Table C.1;
- measurement duration t_M for each measurement;
- description of the test environment;
- A-weighted sound power level from each of the three measurements and the resulting sound power level as emission value;

- A-weighted sound pressure levels from each of the three measurements at the operator's position and the resulting emission sound pressure level;
- place, date of measurement, test laboratory and person responsible.

The test report shall include the statement that the sound power level and the emission sound pressure level at the operator's position have been determined entirely in accordance with the specifications of this annex. The A-weighted sound power level of the machine under test and A-weighted emission sound pressure level at the operator's position shall be rounded down or up to the nearest integral value in dB (< 0,5 round down; ≥ 0,5 round up).

C.8 Declaration and verification of noise emission values

The declared A-weighted sound power level shall be the sum of the measured value and the associated uncertainty K_{WA} (see C.5).

NOTE The declared value of the A-weighted sound power level is identical to the guaranteed sound power level according to 2000/14/EC.

The declared A-weighted emission sound pressure level shall be the sum of the measured value and the associated uncertainty K_{pA} (see C.5).

The noise declaration shall explicitly state that the noise emission values have been obtained according to this noise test code.

Any verification shall be done using this noise test code. If the value measured during verification is less than or equal to the declared value, the declared value is verified.

Annex D (informative)

Examples of paver-finishers

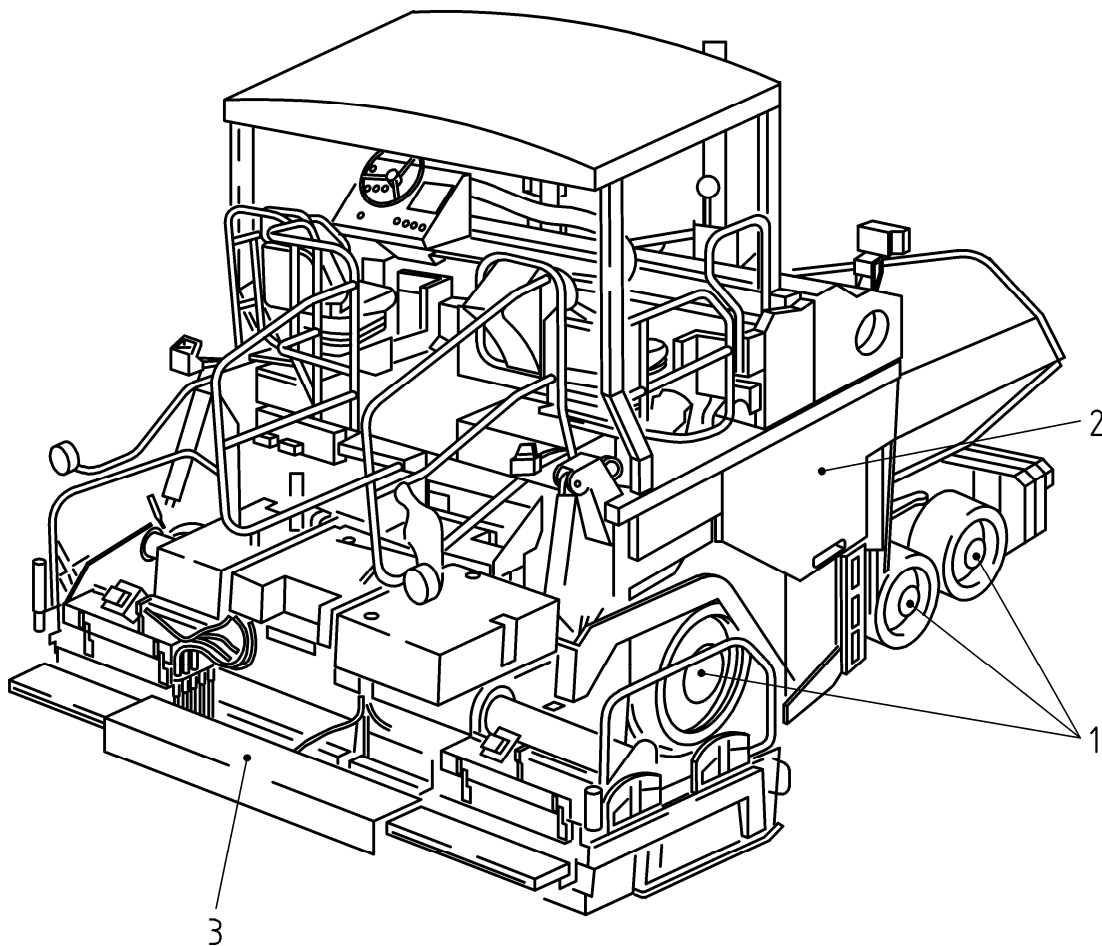

- Key**
- 1 rubber tires
 - 2 tractor unit
 - 3 screed

Figure D.1 — Rubber-tired paver-finisher

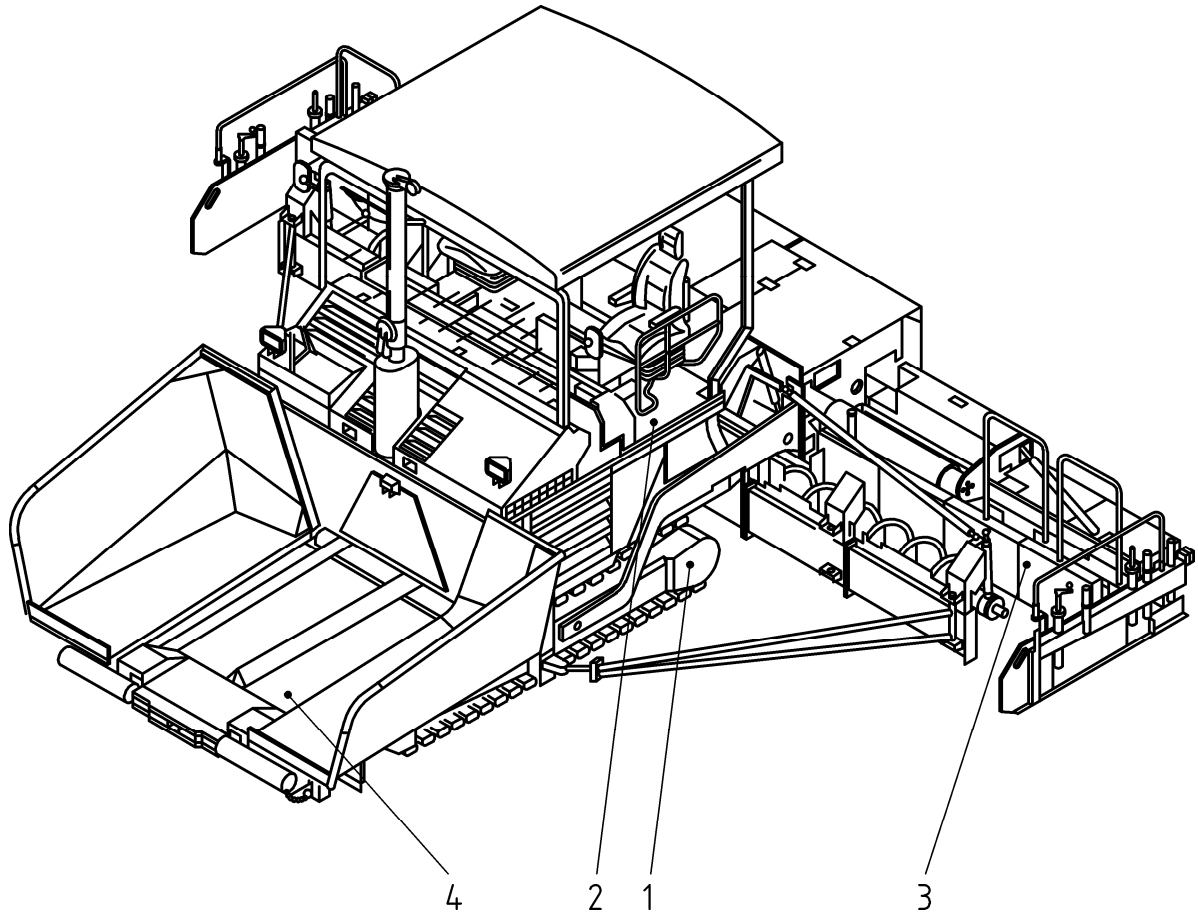

Key

- 1 crawler
- 2 tractor unit
- 3 screed
- 4 hopper

Figure D.2 — Crawler-mounted paver-finisher

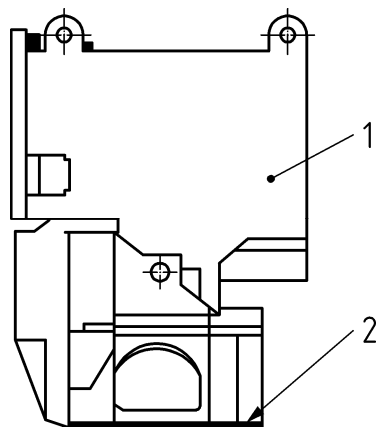

Key

- 1 screed body
- 2 bottom plate

Figure D.3 — Pre-compaction screed

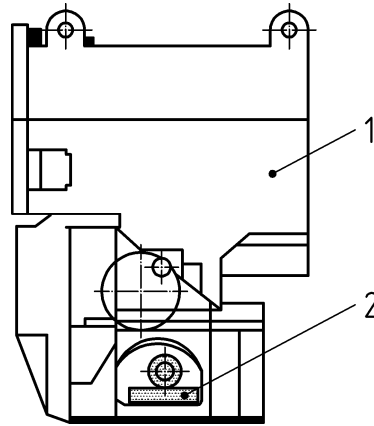

- Key**
- 1 screed body
 - 2 vibrator

Figure D.4 — Compaction screed with vibration

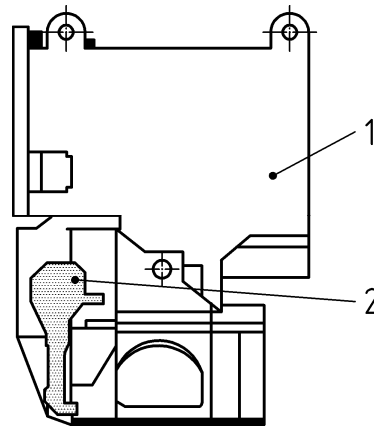

- Key**
- 1 screed body
 - 2 tamper bar

Figure D.5 — Compaction screed with tamper bar

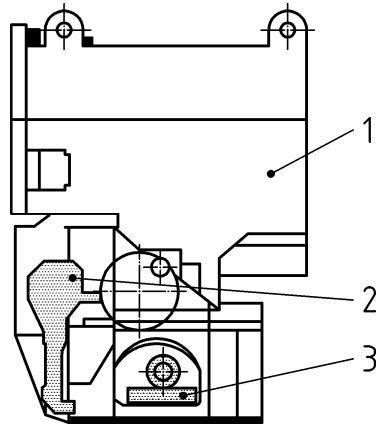

Key

- 1 screed body
- 2 tamper bar
- 3 vibrator

Figure D.6 — High-compaction screed with tamper bar and vibration

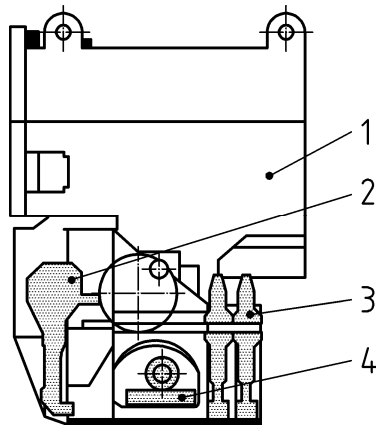

Key

- 1 screed body
- 2 tamper bar
- 3 pressure bar
- 4 vibrator

Figure D.7 — High-compaction screed with tamper bar, vibration and two pressure bars

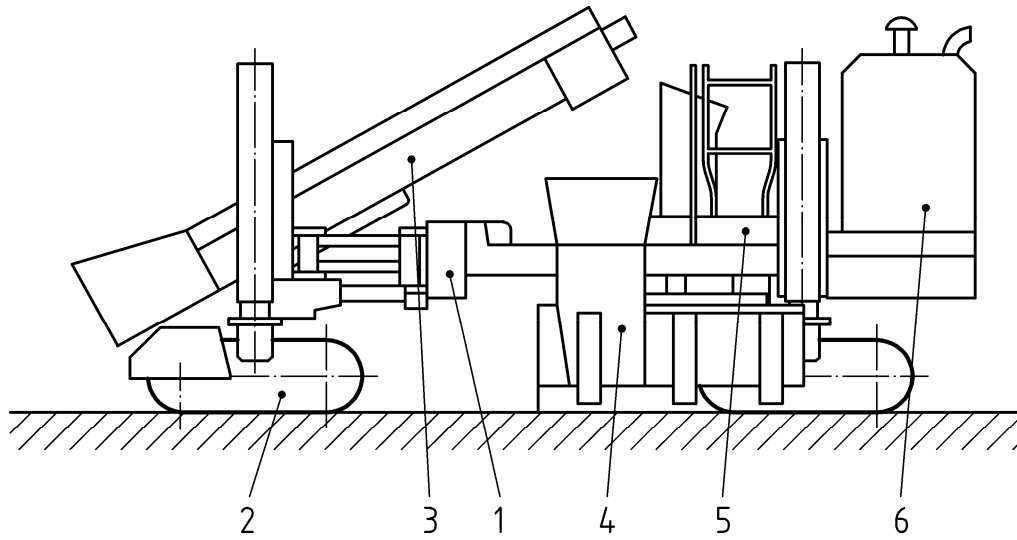

- Key**
- 1 chassis frame
 - 2 crawler
 - 3 conveyor
 - 4 offset mould
 - 5 operator's station
 - 6 power station

Figure D.8 — Slipform paver with offset mould

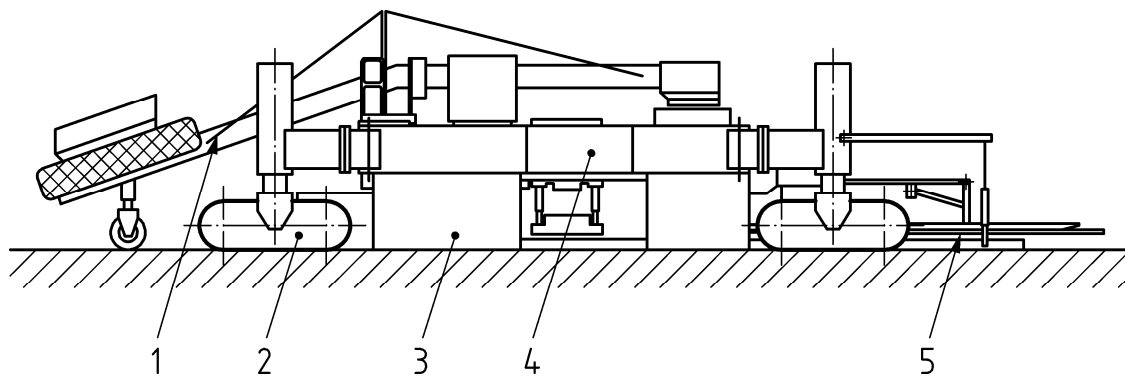

- Key**
- 1 conveyor
 - 2 crawler
 - 3 road mould
 - 4 chassis frame
 - 5 finishing device

Figure D.9 — Slipform paver with road mould

Annex ZA (informative)

Relationship between this European Standard and the Essential Requirements of EC Directive 98/37/EC

This European Standard has been prepared under a mandate given to CEN by the European Commission and the European Free Trade Association to provide a means of conforming to Essential Requirements of the New Approach Directive Machinery 98/37/EC amended by 98/79/EC.

Once this standard is cited in the Official Journal of the European Communities under that Directive and has been implemented as a national standard in at least one Member State, compliance with the normative clauses of this standard confers, within the limits of the scope of this standard, a presumption of conformity with the relevant Essential Requirements of that Directive and associated EFTA regulations.

WARNING — Other requirements and other EU Directives may be applicable to the product(s) falling within the scope of this standard.

Annex ZB (informative)

A1 Relationship between this European Standard and the Essential Requirements of EU Directive 2006/42/EC

This European Standard has been prepared under a mandate given to CEN by the European Commission and the European Free Trade Association to provide a means of conforming to Essential Requirements of the New Approach Directive Machinery 2006/42/EC.

Once this standard is cited in the Official Journal of the European Communities under that Directive and has been implemented as a national standard in at least one Member State, compliance with the normative clauses of this standard confers, within the limits of the scope of this standard, a presumption of conformity with the relevant Essential Requirements of that Directive and associated EFTA regulations.

WARNING — Other requirements and other EU Directives may be applicable to the product(s) falling within the scope of this standard. **A1**

Bibliography

- [1] prEN 12649, *Concrete compactors and floating machines — Safety requirements*

BSI - British Standards Institution

BSI is the independent national body responsible for preparing British Standards. It presents the UK view on standards in Europe and at the international level. It is incorporated by Royal Charter.

Revisions

British Standards are updated by amendment or revision. Users of British Standards should make sure that they possess the latest amendments or editions.

It is the constant aim of BSI to improve the quality of our products and services. We would be grateful if anyone finding an inaccuracy or ambiguity while using this British Standard would inform the Secretary of the technical committee responsible, the identity of which can be found on the inside front cover. Tel: +44 (0)20 8996 9000. Fax: +44 (0)20 8996 7400.

BSI offers members an individual updating service called PLUS which ensures that subscribers automatically receive the latest editions of standards.

Buying standards

Orders for all BSI, international and foreign standards publications should be addressed to Customer Services. Tel: +44 (0)20 8996 9001. Fax: +44 (0)20 8996 7001 Email: orders@bsigroup.com You may also buy directly using a debit/credit card from the BSI Shop on the Website <http://www.bsigroup.com/shop>

In response to orders for international standards, it is BSI policy to supply the BSI implementation of those that have been published as British Standards, unless otherwise requested.

Information on standards

BSI provides a wide range of information on national, European and international standards through its Library and its Technical Help to Exporters Service. Various BSI electronic information services are also available which give details on all its products and services. Contact Information Centre. Tel: +44 (0)20 8996 7111 Fax: +44 (0)20 8996 7048 Email: info@bsigroup.com

Subscribing members of BSI are kept up to date with standards developments and receive substantial discounts on the purchase price of standards. For details of these and other benefits contact Membership Administration. Tel: +44 (0)20 8996 7002 Fax: +44 (0)20 8996 7001 Email: membership@bsigroup.com

Information regarding online access to British Standards via British Standards Online can be found at <http://www.bsigroup.com/BSOL>

Further information about BSI is available on the BSI website at <http://www.bsigroup.com>

Copyright

Copyright subsists in all BSI publications. BSI also holds the copyright, in the UK, of the publications of the international standardization bodies. Except as permitted under the Copyright, Designs and Patents Act 1988 no extract may be reproduced, stored in a retrieval system or transmitted in any form or by any means – electronic, photocopying, recording or otherwise – without prior written permission from BSI.

This does not preclude the free use, in the course of implementing the standard, of necessary details such as symbols, and size, type or grade designations. If these details are to be used for any other purpose than implementation then the prior written permission of BSI must be obtained.

Details and advice can be obtained from the Copyright and Licensing Manager. Tel: +44 (0)20 8996 7070 Email: copyright@bsigroup.com