

BS EN 341:2011



BSI Standards Publication

Personal fall protection equipment — Descender devices for rescue

bsi.

...making excellence a habit.™

National foreword

This British Standard is the UK implementation of EN 341:2011. It supersedes BS EN 341:1993 which is withdrawn.

The UK participation in its preparation was entrusted to Technical Committee PH/5, Personal Fall Protection.

A list of organizations represented on this committee can be obtained on request to its secretary.

This publication does not purport to include all the necessary provisions of a contract. Users are responsible for its correct application.

© BSI 2011

ISBN 978 0 580 65417 6

ICS 13.340.99

Compliance with a British Standard cannot confer immunity from legal obligations.

This British Standard was published under the authority of the Standards Policy and Strategy Committee on 31 August 2011.

Amendments issued since publication

Date	Text affected
------	---------------

EUROPEAN STANDARD

EN 341

NORME EUROPÉENNE

EUROPÄISCHE NORM

June 2011

ICS 13.340.99

Supersedes EN 341:1992

English Version

**Personal fall protection equipment - Descender devices for
rescue**Équipement de protection individuelle contre les chutes -
Descendeurs pour sauvetagePersönliche Absturzschauszüstung - Abseilgeräte zum
Retten

This European Standard was approved by CEN on 25 May 2011.

CEN members are bound to comply with the CEN/CENELEC Internal Regulations which stipulate the conditions for giving this European Standard the status of a national standard without any alteration. Up-to-date lists and bibliographical references concerning such national standards may be obtained on application to the CEN-CENELEC Management Centre or to any CEN member.

This European Standard exists in three official versions (English, French, German). A version in any other language made by translation under the responsibility of a CEN member into its own language and notified to the CEN-CENELEC Management Centre has the same status as the official versions.

CEN members are the national standards bodies of Austria, Belgium, Bulgaria, Croatia, Cyprus, Czech Republic, Denmark, Estonia, Finland, France, Germany, Greece, Hungary, Iceland, Ireland, Italy, Latvia, Lithuania, Luxembourg, Malta, Netherlands, Norway, Poland, Portugal, Romania, Slovakia, Slovenia, Spain, Sweden, Switzerland and United Kingdom.

EUROPEAN COMMITTEE FOR STANDARDIZATION
COMITÉ EUROPÉEN DE NORMALISATION
EUROPÄISCHES KOMITEE FÜR NORMUNG**Management Centre: Avenue Marnix 17, B-1000 Brussels**

Contents

Page

Foreword.....	3
1 Scope	4
2 Normative references	4
3 Terms, definitions and classes	4
3.1 Terms and definitions	4
3.2 Classes	5
4 Requirements	6
4.1 General.....	6
4.2 Design, materials and construction.....	6
4.3 Dynamic strength.....	7
4.4 Function.....	8
4.5 Descent energy	8
4.6 Static strength.....	9
4.7 Corrosion resistance	9
4.8 Additional requirements for manually-operated descender devices (type 2)	9
4.9 Additional requirements for descender devices, class D.....	9
4.10 Marking and information	9
5 Test methods.....	9
5.1 Test samples	9
5.2 Examination of design	10
5.3 Dynamic strength test	10
5.4 Function tests	12
5.5 Descent energy test.....	15
5.6 Static strength test	17
5.7 Operating force test.....	18
5.8 Holding force test	18
5.9 Line integrity test.....	18
5.10 Corrosion resistance test	19
6 Marking	19
7 Information supplied by the manufacturer	20
Annex A (informative) Significant technical changes between this European Standard and EN 341:1992.....	21

Figures

Figure 1 — Dynamic strength test for descender devices that normally travel with the user	11
Figure 2 — Dynamic strength test for descender devices that normally do not travel with the user	12
Figure 3 — Example of test apparatus for test of integrity of lines and for descent energy of an automatic descender device (type 1).....	16
Figure 4 — Example of test apparatus for test of integrity of lines and for descent energy of a manually-operated descender device (type 2).....	17

Foreword

This document (EN 341:2011) has been prepared by Technical Committee CEN/TC 160 "Protection against falls from a height including working belts", the secretariat of which is held by DIN.

This European Standard shall be given the status of a national standard, either by publication of an identical text or by endorsement, at the latest by December 2011, and conflicting national standards shall be withdrawn at the latest by December 2011.

Attention is drawn to the possibility that some of the elements of this document may be the subject of patent rights. CEN [and/or CENELEC] shall not be held responsible for identifying any or all such patent rights.

This document supersedes EN 341:1992.

Annex A provides details of significant technical changes between this European Standard and EN 341:1992.

According to the CEN/CENELEC Internal Regulations, the national standards organizations of the following countries are bound to implement this European Standard: Austria, Belgium, Bulgaria, Croatia, Cyprus, Czech Republic, Denmark, Estonia, Finland, France, Germany, Greece, Hungary, Iceland, Ireland, Italy, Latvia, Lithuania, Luxembourg, Malta, Netherlands, Norway, Poland, Portugal, Romania, Slovakia, Slovenia, Spain, Sweden, Switzerland and the United Kingdom.

1 Scope

This European Standard specifies requirements, test methods, marking and information to be supplied by the manufacturer for descender devices, which include descent lines (hereinafter referred to as lines), intended for rescue and to protect against falls in a rescue system, which is a personal fall protection system. This European Standard does not specify requirements for descender devices that are used for descending in mountaineering, rope access or work positioning systems.

NOTE A descender device which enables the user to rescue himself and which conforms to this European Standard is personal protective equipment (PPE).

2 Normative references

The following referenced documents are indispensable for the application of this document. For dated references, only the edition cited applies. For undated references, the latest edition of the referenced document (including any amendments) applies.

EN 362, *Personal protective equipment against falls from a height — Connectors*

EN 363:2008, *Personal fall protection equipment — Personal fall protection systems*

EN 364:1992, *Personal protective equipment against falls from a height — Test methods*

EN 365:2004, *Personal protective equipment against falls from a height — General requirements for instructions for use, maintenance, periodic examination, repair, marking and packaging*

EN 1496:2006, *Personal fall protection equipment — Rescue lifting devices*

EN 1891:1998, *Personal protective equipment for the prevention of falls from a height — Low stretch kernmantel ropes*

EN 12385-1, *Steel wire ropes — Safety — Part 1: General requirements*

EN ISO 9227, *Corrosion tests in artificial atmospheres — Salt spray tests (ISO 9227:2006)*

3 Terms, definitions and classes

For the purposes of this document, the terms and definitions of EN 363:2008 and the following apply.

3.1 Terms and definitions

3.1.1

descender device

automatic (type 1) or manually-operated (type 2) device, including a line, by which persons can, at a limited velocity, rescue themselves or others from a higher to a lower position in such a way that a free fall is prevented

NOTE A line could be e.g. wire rope, textile rope, or webbing.

3.1.1.1

automatic descender device (type 1)

descender device with a braking system that does not require an intervention by the user once the descent has commenced

3.1.1.2

manually-operated descender device (type 2)

descender device with a braking system that requires an intervention by the user

3.1.1.3

control device

integral element of the descender device normally operated by hand, used to control the velocity of descent down the line

3.1.1.4

panic locking element

integral part or function of the control device which stops or slows down the descent and thereby prevents an uncontrolled descent or a fall if the user panics and operates the descender device beyond its intended control parameters

3.1.2

descent energy

energy measured in joules and expressed as W , which results from the product of the descent load, the gravity, the descent height and the number of descents

NOTE Descent energy $W = m \times g \times h \times n$

where

W is the descent energy, expressed in joules (J);

m is the descent load, expressed in kilograms (kg);

g is the gravity 9,81 m/s²;

h is the descent height, expressed in metres (m);

n is the number of descents.

3.1.3

minimum rated load

minimum mass of the person(s), including tools and equipment, for the descender device, as specified by the manufacturer

NOTE Minimum rated load is expressed in kilograms.

3.1.4

maximum rated load

maximum mass of the person(s), including tools and equipment, for the descender device, as specified by the manufacturer

NOTE Maximum rated load is expressed in kilograms.

3.2 Classes

Descender devices are classified as follows:

- a) class A: descent energy W up to $7,5 \times 10^6$ J;
- b) class B: descent energy W up to $1,5 \times 10^6$ J;
- c) class C: descent energy W up to $0,5 \times 10^6$ J;

- d) class D: For only one descent. Descent energy depends on the maximum descent height and the maximum rated load.

NOTE In practice, descender devices are subjected to different loads. A descender device for descending, e. g. 100 passengers from a cable car at a height of 100 m, has to meet more severe requirements than a descender device used by a crane driver to descend by himself from a height of 20 m only once.

4 Requirements

4.1 General

4.1.1 Minimum rated load

The minimum rated load shall be specified by the manufacturer.

4.1.2 Maximum rated load

The maximum rated load shall be specified by the manufacturer and shall be at least 100 kg.

4.2 Design, materials and construction

4.2.1 General

Materials which may come into contact with the skin of a user shall not be known to, or suspected to, adversely affect user hygiene or health, e.g. cause irritating or sensitization effects, during normal use of the descender device.

Descender devices shall not have sharp or rough edges that may cut, abrade or otherwise damage rope or webbing or cause injury to the user.

When descender devices in accordance with this standard have a rescue lifting function, they shall in addition to this European Standard conform to EN 1496:2006, class A.

Connectors shall conform to EN 362.

4.2.2 Lines

Lines shall be made from steel or stainless steel wire rope, textile rope or webbing.

Lines shall have at least one termination. Line ends that do not have a termination shall have an end stop.

The ends of the lines shall be protected against slipping through the descender device unintentionally.

Lines including their termination(s) shall be of a type capable of visual inspection or else subject to manufacturers' guidance for appropriate examination.

4.2.2.1 Wire rope lines

Wire rope lines shall be made from one piece and shall be stress and torsion relieved.

Wire rope lines made from steel except stainless steel shall be galvanized to EN 12385-1.

The nominal tensile strength of the wires of the steel or stainless steel wire rope shall not exceed 1960 N/mm².

NOTE 1 A limit of the nominal tensile strength is necessary, because the wires become too brittle with a higher nominal tensile strength.

NOTE 2 Manufacturers of descender devices should be particularly careful when selecting lines made from stainless steel as some types of stainless steel can have unpredictable fatigue and corrosion characteristics.

4.2.2.2 Textile rope lines

Textile rope lines for descender devices, class A, B or C shall be of kernmantel construction and shall conform to EN 1891:1998, type A, 4.1 to 4.10.

4.2.2.3 Webbing lines

Webbing lines shall meet the requirements of EN 1891:1998, 4.5, 4.6 and 4.10.

Webbing lines shall be made from virgin filament or multi-filament synthetic fibres suitable for the use intended. The breaking tenacity of the synthetic fibre shall be known to be at least 0,6 N/tex.

The materials used for the construction of the webbing line shall be known to have a melting point of more than 195 °C. Webbing lines made from polypropylene or polyethylene shall not be used.

4.2.2.4 Line integrity

When tested in accordance with 5.9, lines made of stainless steel wire rope or made of textiles containing aramid fibres shall withstand a test force as given in 4.6, applied for 3 min.

4.2.2.5 Terminations, end stops

Lines shall be terminated in such a manner that they can be connected, directly or by an appropriate connector as specified by the manufacturer, to a body holding device, e.g. a rescue harness or a rescue loop, or to an anchor device.

Reinforcement or another method shall be used to protect terminations from concentrated wear at all webbing-to-metal fitting interfaces.

All splices shall be secured to prevent the splice from coming open in use.

Eye splices in laid fibre rope shall consist of at least four tucks using all the yarns in the strands. The length of the splicing tails emerging after the last tuck shall be at least one rope diameter.

Threads used for sewing shall be physically compatible with the webbing/rope, and the quality shall be compatible to that of the webbing/rope. They shall, however, be of a contrasting shade or colour in order to facilitate visual inspection.

When using a knot for forming a termination or as an end stop, the knot shall be secured so that it cannot be opened without the use of a tool. When tested in accordance with 5.6, the tail end of the knot shall have a minimum length of 100 mm.

Webbing ends shall be sealed or otherwise prevented from unravelling.

Eye terminations of wire ropes shall be made with thimbles and by splices or with thimbles and by pressed ferrules.

4.3 Dynamic strength

When tested in accordance with 5.3, the descender device shall not release the test mass and no part of the descender device shall show any signs of breaking or tearing.

4.4 Function

4.4.1 Classes A, B and C

When tested in the dry and wet condition in accordance with 5.4.1 and 5.4.2:

- a) it shall be possible to maintain a continuous descent velocity between 0,5 m/s and 2 m/s;
- b) in the case of a manually-operated descender device, the velocity shall not exceed 2 m/s when the control device is in a hands-off position or if applicable any panic locking element is engaged;
- c) none of the parts of the descender device handled by the user to control the descents shall develop a temperature higher than 48 °C during the descents.

When tested in wet and cold conditions in accordance with 5.4.3, it shall be possible to maintain a continuous descent velocity between 0,5 m/s and 2 m/s.

If the manufacturer claims that the descender device can be used at temperatures lower than – 4 °C, it shall be possible to maintain a continuous descent velocity between 0,5 m/s and 2 m/s when tested in very cold conditions in accordance with 5.4.4.

4.4.2 Class D

When tested in the dry condition in accordance with 5.4.1:

- a) it shall be possible to maintain a continuous descent velocity at a maximum of 2 m/s;
- b) in the case of a manually-operated descender device, the velocity shall not exceed 2 m/s when the control device is in a hands-off position or if applicable any panic locking element is engaged;
- c) none of the parts of the descender device handled by the user to control the descent shall develop a temperature higher than 48 °C during the descent.

If the manufacturer claims that the descender device can be used in wet conditions, it shall be possible to maintain the descent velocity at a maximum of 2 m/s when tested in the wet conditions in accordance with 5.4.2.

If the manufacturer claims that the descender device can be used in the temperature range of (- 4 to + 2) °C, it shall be possible to maintain the descent velocity at a maximum of 2 m/s when tested in the wet and cold conditions in accordance with 5.4.3.

If the manufacturer claims that the descender device can be used at temperatures lower than – 4 °C, it shall be possible to maintain a continuous descent velocity at a maximum of 2 m/s when tested in the very cold conditions in accordance with 5.4.4.

4.5 Descent energy

When tested in accordance with 5.5, with the descents being carried out in succession, descender devices, class A, B and C shall meet the following requirements:

- a) they shall resist the descent energy determined for their class;
- b) the temperature due to friction shall not affect the function of the descender device;
- c) it shall be possible to maintain the descent velocity between 0,5 m/s and 2 m/s;
- d) none of the parts of the descender device handled by the user to control the descents shall develop a temperature higher than 48 °C during the descents.

NOTE This test is not required for Class D descender devices, as they are intended for a single use only.

4.6 Static strength

When tested in accordance with 5.6, first test, descender devices, class A, B and C shall withstand a test force of 10 times the maximum rated load, but at least 12 kN, applied for 3 min.

When tested in accordance with 5.6, first test, descender devices, class D shall withstand a test force of twice the maximum impact force recorded in the dynamic test of 5.3, but at least 5 times the maximum rated load, applied for 3 min. If manually-operated devices are tested in several locked positions, the highest of the measured values shall be used as a basis for establishing the static strength test force.

When tested in accordance with 5.6, second test, descender devices, classes A, B, C and D shall withstand a test force of 5 times the maximum rated load, but at least 6 kN, applied for 3 min.

4.7 Corrosion resistance

After testing in accordance with 5.10, no part of the descender device shall show evidence of corrosion that would affect its function.

NOTE 1 White scaling or tarnishing is acceptable if the function is not impaired.

NOTE 2 Conformity with this requirement does not imply suitability for use in a marine environment.

4.8 Additional requirements for manually-operated descender devices (type 2)

4.8.1 Operating force

When tested in accordance with 5.7, with a force equal to the maximum rated load, the force to release and operate the integral manually-operated control element of the descender device shall not exceed 450 N.

4.8.2 Holding force

When descender devices of a design where the user controls the descent manually by holding the line are tested in accordance with 5.8, with a force equal to the maximum rated load, the maximum force necessary to hold the test mass shall not exceed 200 N.

4.9 Additional requirements for descender devices, class D

After testing in accordance with 5.4, Class D descender devices shall indicate clearly that they have been used.

4.10 Marking and information

Marking of the descender device shall be in accordance with Clause 6.

Information shall be supplied with the descender device in accordance with Clause 7.

5 Test methods

5.1 Test samples

A minimum of two new descender devices shall be provided: one for the purposes of the tests specified in 5.2 and 5.10 and one for the purposes of the tests specified in 5.3, 5.4, 5.5, 5.6, 5.7 and 5.8.

NOTE Depending on the configuration, the claim of the manufacturer for the intended use, the material of the line and the class of the device, more than two samples may be required.

5.2 Examination of design

Confirm by reference to appropriate documentation accompanying the descender device and by measurement and by normal or corrected vision and/or tactile examination of the descender device that it conforms to 4.1, 4.2.1, 4.2.2, 4.2.2.1, 4.2.2.2, 4.2.2.3 and 4.2.2.5. If necessary to examine internal parts, dismantle the descender device.

5.3 Dynamic strength test

The test apparatus shall conform to 4.4.1, 4.5, 4.6 and, if applicable, to 4.4.2 of EN 364:1992.

Attach a new descender device by its connecting element or the line of the descender device, as appropriate, to the anchor point of the test apparatus, in accordance with the information supplied by the manufacturer, see Figures 1 or 2. Manually-operated descender devices shall be tested in each locked position intended by the manufacturer and described in the information supplied by the manufacturer.

Withdraw the line by $(4\,000^{+50}_0)$ mm from the descender device and attach the rigid steel test mass in accordance with the maximum rated load to the termination of the line or to the descender device, as appropriate. In the case of descender devices with an automatic retraction function, prevent the line from retracting by a clamp.

For descender devices, class D, attach a load cell between the descender device and the anchor point of the test apparatus.

Raise the test mass by (600^{+50}_0) mm, with a maximum horizontal distance of 300 mm from the anchor point.

Hold the test mass by the quick release device. Release the test mass without initial velocity.

For descender devices, class D, measure and record the impact force in each dynamic test.

Check that the descender device does not release the test mass and does not show any signs of breaking or tearing.

If the descender device is designed both to travel with the user and to be operated from a fixed position, carry out the test in both configurations. A new descender device may be used for each configuration.

Dimensions in millimetres

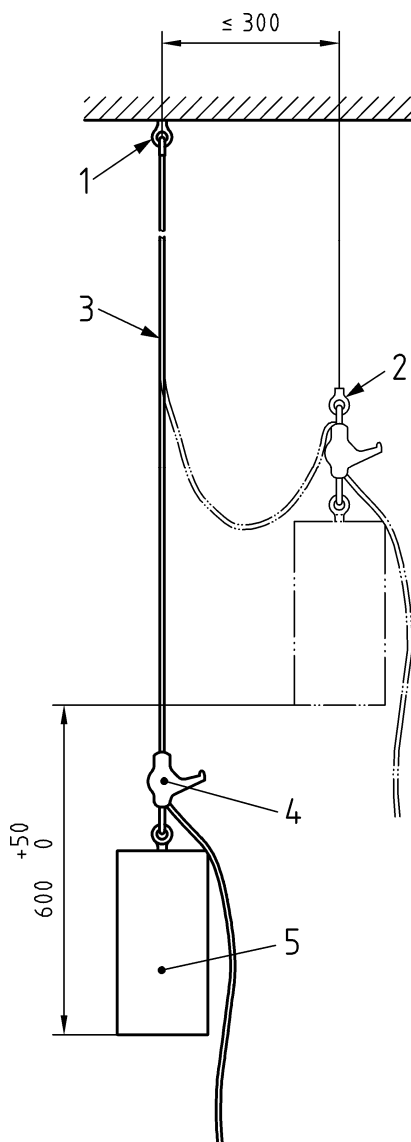

Key

- 1 anchor point
- 2 quick release device
- 3 line
- 4 descender device
- 5 test mass

Figure 1 — Dynamic strength test for descender devices that normally travel with the user

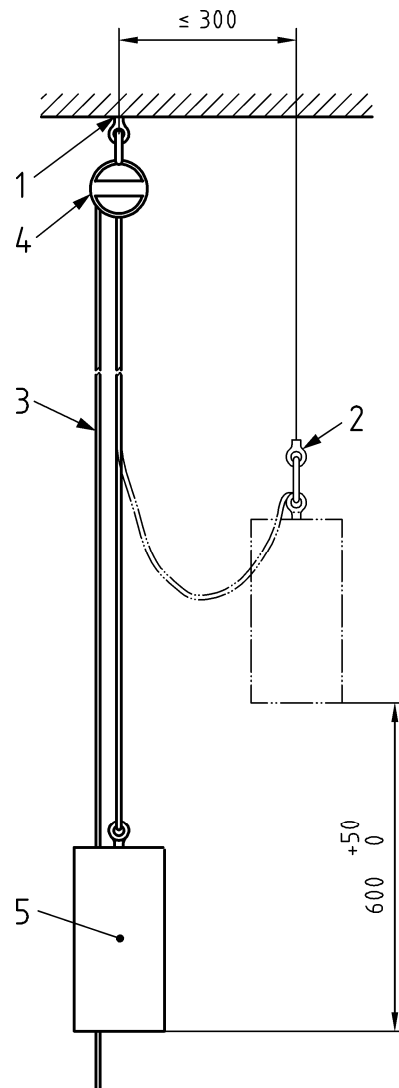

Key

- 1 anchor point
- 2 quick release device
- 3 line
- 4 descender device
- 5 test mass

Figure 2 — Dynamic strength test for descender devices that normally do not travel with the user

5.4 Function tests

5.4.1 Dry condition

Using the descender device tested in 5.3, store the descender device at a temperature of $(20 \pm 2) ^\circ\text{C}$ and a humidity of $(65 \pm 5) \%$ for at least 72 h.

Attach the descender device to the anchor point of the test apparatus in accordance with the information supplied by the manufacturer. If there is more than one position given, perform the function test in each position. Carry out the following descents at the maximum descent height and operate the descender device as described in the information supplied by the manufacturer:

- a) a first descent from top to bottom of the line with a test mass equivalent to the minimum rated load, with a tolerance of $(\begin{smallmatrix} +2 \\ 0 \end{smallmatrix})$ %;
- b) a second descent from top to bottom of the line with a test mass equivalent to the maximum rated load plus 25 %, with a tolerance of $(\begin{smallmatrix} +2 \\ 0 \end{smallmatrix})$ %.

For descender devices, class D, a new descender device tested to 5.3 may be used for the second descent.

During each descent, check that the descent is continuous, measure the time and calculate the mean velocity based on the descent height.

For manually-operated descender devices, check that the velocity does not exceed 2 m/s when the control device is in a hands-off position or if applicable any panic locking element is engaged.

Within 30 s of completing the descents with the maximum rated load plus 25 %, measure the temperature on any parts of the descender device that will be touched to control the descent when operated as described in the information supplied by the manufacturer.

For descender devices, class D, check if the descender device indicates that it has been used.

5.4.2 Wet condition

Immerse the descender device tested in 5.4.1 in clean, fresh water within a temperature range of (10 to 30) °C for $(60 \begin{smallmatrix} +5 \\ 0 \end{smallmatrix})$ min. Remove from the water and allow to drain for (15 ± 1) min.

Within 2 min of completion of the draining process, attach the descender device to the anchor point of the test apparatus, in accordance with the information supplied by the manufacturer. If there is more than one position given, perform the function test in each position. Carry out the following descents at the maximum descent height:

- a) a first descent from top to bottom of the line with a test mass equivalent to the minimum rated load, with a tolerance of $(\begin{smallmatrix} +2 \\ 0 \end{smallmatrix})$ %;
- b) a second descent from top to bottom of the line with a test mass equivalent to the maximum rated load plus 25 %, with a tolerance of $(\begin{smallmatrix} +2 \\ 0 \end{smallmatrix})$ %.

Operate the descender device in accordance with the information supplied by the manufacturer.

During each descent, check that the descent is continuous, measure the time and calculate the mean velocity based on the descent height.

For manually-operated descender devices, check that the velocity does not exceed 2 m/s when the control device is in a hands-off position or if applicable any panic locking element is engaged.

For descender devices, class D, a new descender device may be used for each descent.

For descender devices, class D, check if the descender device indicates that it has been used.

5.4.3 Wet and cold condition

Immerse a new descender device in clean, fresh water within a temperature range of (10 to 30) °C for (60⁺⁵₀) min. Remove from the water and allow to drain for (15 ± 1) min. Wrap the descender device in an insulating blanket (not specified) and subject them to a temperature of (-4⁻²₀) °C for a minimum of 4 h.

NOTE The insulating blanket is required to enable the descender device to be within the conditioned temperature range at the time the test is carried out.

Within 2 min of removal from the conditioned atmosphere, attach the descender device to the anchor point of the test apparatus, in accordance with the information supplied by the manufacturer. If there is more than one position given, perform the function test in each position after re-conditioning. Carry out the following descents using a descender device with a line of a minimum length of 5 m in a laboratory or at the maximum descent height. Operate the descender device in accordance with the information supplied by the manufacturer as follows:

- a) a first descent from top to bottom of the line with a test mass equivalent to the minimum rated load, with a tolerance of (⁺²₀) %;
- b) after re-conditioning, a second descent from top to bottom of the line with a test mass equivalent to the maximum rated load plus 25 %, with a tolerance of (⁺²₀) %.

During each descent, check that the descent is continuous, measure the time and calculate the mean velocity based on the descent height.

For manually-operated descender devices, check that the velocity does not exceed 2 m/s when the control device is in a hands-off position or if applicable any panic locking element is engaged.

A new descender device may be used for each descent.

For descender devices, class D, check if the descender device indicates that it has been used.

5.4.4 Very cold condition

Immerse a new descender device in clean, fresh water within a temperature range of (10 to 30) °C for (60⁺⁵₀) min. Remove from the water and allow to drain for (15 ± 1) min. Wrap the descender device in an insulating blanket (not specified) and subject them to the lowest temperature specified by the manufacturer, with a tolerance of (⁻²₀) °C for a minimum of 4 h.

NOTE The insulating blanket is required to enable the descender device to be within the conditioned temperature range at the time the test is carried out.

Within 2 min of removal from the conditioned atmosphere, attach the descender device to the anchor point of the test apparatus, in accordance with the information supplied by the manufacturer. If there is more than one position given, perform the function test in each position after re-conditioning. Carry out the following descents using a descender device with a line of a minimum length of 5 m in a laboratory or at the maximum descent height:

- a) a first descent from top to bottom of the line with a test mass equivalent to the minimum rated load, with a tolerance of (⁺²₀) %;
- b) after re-conditioning, a second descent from top to bottom of the line with a test mass equivalent to the maximum rated load plus 25 %, with a tolerance of (⁺²₀) %.

Operate the descender device in accordance with the information supplied by the manufacturer.

During each descent, check that the descent is continuous, measure the time and calculate the mean velocity based on the descent height.

For manually-operated descender devices, check that the velocity does not exceed 2 m/s when the control device is in a hands-off position or if applicable any panic locking element is engaged.

A new descender device may be used for each descent.

For descender devices, class D, check if the descender device indicates that it has been used.

5.5 Descent energy test

Using the descender device tested in 5.4.2, carry out the descent energy test in the direction of travel of the descender device, which is the same as that in practice, as described in the information supplied by the manufacturer. If there is more than one direction or position given, perform the descent energy test in each direction or position. Carry out the descent energy test with a test mass equivalent to the maximum rated load with a tolerance of $(\begin{smallmatrix} +2 \\ 0 \end{smallmatrix})$ % at the maximum height.

Calculate the number of descents with the formula given in 3.1.2 in order to reach the descent energy of the named class.

Carry out the individual descents at such chronological intervals as they would be in practice.

During the last descent, measure the time and calculate the mean velocity based on the descent height.

Within 30 s of completing the descents, measure the temperature on any parts of the descender device that have to be touched to control the descent when operated as described in the information supplied by the manufacturer.

The test of the descent energy may also be carried out with a mechanical test apparatus, see Figures 3 and 4 for examples of such test apparatus. This apparatus shall be so designed that it fulfils the requirements of this subclause for the test procedure. Arrange the descender device, the load in the line and the length of the line so that they correspond to the use in practice.

Dimensions in millimetres

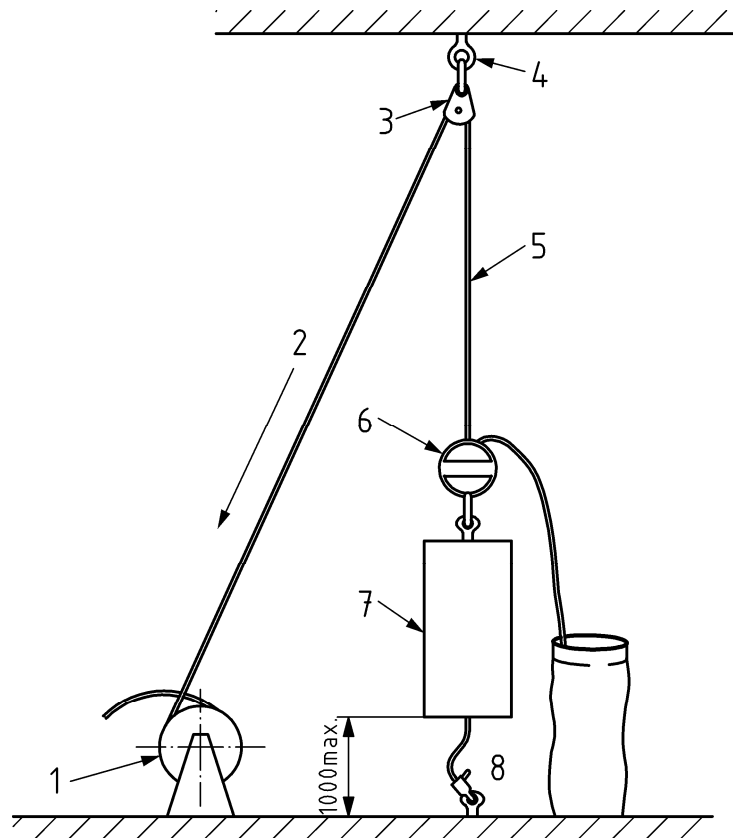

Key

- 1 line pull-through system, e.g. a powered capstan
- 2 direction of travel of line
- 3 free-running pulley
- 4 anchor point
- 5 line
- 6 descender device (automatic)
- 7 test mass
- 8 test mass retention lanyard

Figure 3 — Example of test apparatus for test of integrity of lines and for descent energy of an automatic descender device (type 1)

Dimensions in millimetres

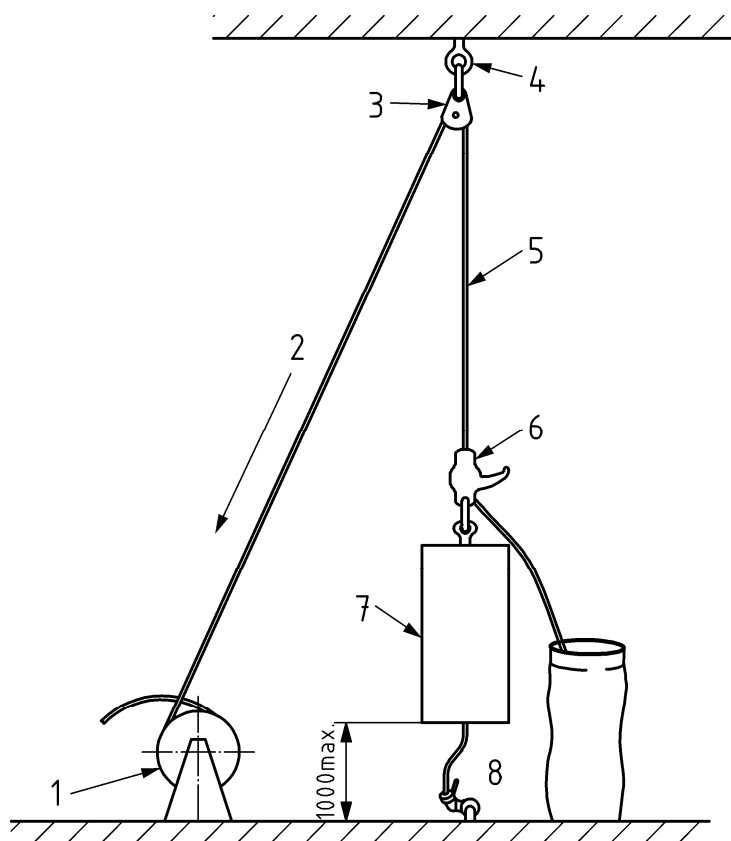

Key

- 1 line pull-through system, e.g. a powered capstan
- 2 direction of travel of line
- 3 free-running pulley
- 4 anchor point
- 5 line
- 6 descender device (manually-operated)
- 7 test mass
- 8 test mass retention lanyard

Figure 4 — Example of test apparatus for test of integrity of lines and for descent energy of a manually-operated descender device (type 2)

5.6 Static strength test

The test apparatus shall conform to 4.1 of EN 364:1992.

Install the descender device tested in 5.5 (class A, B and C) or 5.4.1 (class D), as appropriate, in the test apparatus in such a way that the force can be applied between the attachment point of the descender device and the termination of the line. Apply the force specified in 4.6, with a tolerance of $(\begin{smallmatrix} +0,2 \\ 0 \end{smallmatrix})$ kN. If necessary, the ingoing line may be fixed. Maintain the force for $(3\begin{smallmatrix} +0,25 \\ 0 \end{smallmatrix})$ min. Check if the descender device withstands the force.

If the ingoing line is fixed in such a way that the force at the termination of the line is less than that specified in 4.6, carry out a separate test on the line including termination to check that the line and its termination withstand the force specified in 4.6, with a tolerance of $(\begin{smallmatrix} +0,2 \\ 0 \end{smallmatrix})$ kN, for $(3\begin{smallmatrix} +0,25 \\ 0 \end{smallmatrix})$ min.

For a second test, depending on the design of the descender device, either fully extract the line or pull the line through the device up to the line end. Make a termination on the descent line approximately 1 m from the device in an appropriate way. Install the descender device in the test apparatus in such a way that the force can be applied between the attachment point of the descender device and the termination, in order that the line end will be loaded. Apply the force specified in 4.6, with a tolerance of $(\begin{smallmatrix} +0,2 \\ 0 \end{smallmatrix})$ kN. Maintain the force for $(3\begin{smallmatrix} +0,25 \\ 0 \end{smallmatrix})$ min. Check if the descender device withstands the force.

When the line incorporates a knot for forming a termination or end stop, measure the length of the tail end of the knot.

5.7 Operating force test

Carry out the test before the function tests. Attach the descender device by its connecting element or the line of the descender device, as appropriate, to the anchor point of the test apparatus, in accordance with the information supplied by the manufacturer. Withdraw $(1\ 000 \pm 50)$ mm of the line up-line from the descender device. Arrange the manually-operated control element in the hands-off position and apply to the descender device a mass or equivalent force equal to the maximum rated load. Allow a tolerance of $(\begin{smallmatrix} +2 \\ 0 \end{smallmatrix})$ % on the mass or equivalent force. Measure the force applied at the manually-operated control element in a manner that is representative of the direction and force required to start the descent.

If the descender device is designed both to travel with the user and to be operated from a fixed position, carry out the test in both configurations.

5.8 Holding force test

Carry out the test two times; one before the function tests and one after the descent energy test.

Attach the descender device by its connecting element or the line of the descender device, as appropriate, to the anchor point of the test apparatus, in accordance with the information supplied by the manufacturer. Withdraw $(1\ 000 \pm 50)$ mm of the line up-line from the descender device. Apply a mass or equivalent force equal to the maximum rated load to the attachment point of the descender device. Allow a tolerance of $(\begin{smallmatrix} +2 \\ 0 \end{smallmatrix})$ % on the mass or equivalent force. Measure the force applied to the line going in the descender device necessary to hold the mass.

If the descender device is designed both to travel with the user and to be operated from a fixed position, carry out the test in both configurations.

5.9 Line integrity test

Carry out the test with the stainless steel or aramid line on a new descender device conditioned as in accordance with 5.4.1. Set up the test using the same mechanical test apparatus as employed in 5.5, e.g. as in Figure 3 or Figure 4, depending on the type of descender device being used in the test. Attach the descender device by its attachment point to a test mass equivalent to the maximum rated load, with a tolerance of $(\begin{smallmatrix} +2 \\ 0 \end{smallmatrix})$ %, using an appropriate connector and lanyard, if necessary. Ensure that the line is long enough to allow a pass of the line through the descender device of at least 2,0 m. Suspend the test mass and descender device from the test machine by the line through a free-running pulley attached to the test machine at an appropriate height. Connect the free end of the line to the line pull-through system, e.g. a powered capstan. See Figure 3 for type 1 descender devices and Figure 4 for type 2 descender devices. Ensure that the direction/s of travel of the line is/are the same as that/those in practice, as described in the information supplied by the manufacturer.

Operate the line pull-through system so that the test mass is maintained off the ground within a range of 0 mm to 1 000 mm of movement. Carry out the test so that the same section of line passes through the descender device by at least 2 m for each pass.

Carry out a number of passes equal to the maximum number of descents specified for the descender device by the manufacturer. Carry out the repeat passes with an interval as short as possible between them and in one continuous operation, but account may be taken of what the chronological intervals would be in practice.

Install the 2 m length of line used in the passes in a standard static testing machine of appropriate range so that the distance between the clamps or other types of fastening arrangement is $(1\ 000^{+100}_0)$ mm. Attach the test piece in such a manner that the fastening arrangement does not affect the results of the test. Apply the force specified in 4.6, with a tolerance of $(^{+0,2}_0)$ kN. The crosshead velocity shall conform to 4.1 of EN 364:1992. Maintain the force for a period of $(3^{+0,25}_0)$ min and check if the line withstands the force.

5.10 Corrosion resistance test

Expose the descender device to the neutral salt spray test in accordance with EN ISO 9227 for a period of $(24^{+0,5}_0)$ h. Dry for (60) min at (20 ± 2) °C. Then repeat the procedure, so that the descender device is subjected in total to $(24^{+0,5}_0)$ h exposure and (60^{+5}_0) min drying plus another $(24^{+0,5}_0)$ h exposure and $(60^{+0,5}_0)$ min drying.

Examine the descender device and check that its function is not impaired, i.e. that it operates as intended. Where necessary to gain visual access to internal components, dismantle the descender device. Check if any evidence of corrosion is shown that would affect the function of the descender device.

6 Marking

The marking on the descender device shall conform to 4.8 of EN 365:2004. In addition, the marking shall include:

a) On the device:

- 1) number and year of this European Standard followed by a stroke and then the type (type 1 for automatic, type 2 for manually-operated devices) and class of the descender device, e. g. EN 341:2011/1A;
- 2) maximum descent height in metres;
- 3) maximum and minimum rated load in kilograms;
- 4) lowest temperature at which the device may be used;
- 5) If the line can be removed from the device without tools:
 - i) an indication of the model and type/identification mark of the appropriate line;
 - ii) a sketch showing the route the line takes through the device;
- 6) descender devices, class D: 'FOR SINGLE USE ONLY' shall be marked on the descender device or on an attached label or on the packaging.

b) On the termination of the line:

- 1) name or logo of the manufacturer of the descender device;
- 2) year of production of the line.

7 Information supplied by the manufacturer

The information supplied by the manufacturer shall conform to EN 365. In addition, it shall include at least advice or information as follows:

- a) a warning that the descender device should only be used by a person competent in its use or following clear emergency protocols;
- b) maximum rated load, minimum rated load and maximum descent height of the descender device;
- c) on the recommended types of body-holding device that are to be used with the descender device;
- d) lowest temperature at which the descender device may be used;
- e) how to connect the descender device to the user and to the anchor point;
- f) where appropriate, means or method to allow the descender device to be tied or locked-off manually, to permit hands-off suspension of the user;
- g) that descender devices installed at a workstation and left in place between inspections should be protected adequately against environmental conditions;
- h) a warning that the connection of the descender device to the anchor point should be arranged so that the descent is not impeded;
- i) that any slack in the line between the user and the anchor point should be avoided;
- j) direction in which the descender device operates;
- k) on descent energy and how to calculate the maximum descent distance and maximum number of descents;
- l) for descender devices with lines made of stainless steel or containing aramid fibres, advice on the maximum number of descents allowed before service and/or replacement;
- m) on which are the attachment points of the descender device for connection of the user and/or to the anchor point;
- n) for any descender device that requires control of the tail of the rope, a warning that it is vital to keep control of the tail rope to reduce the risk of serious injury or death;
- o) a warning that it is vital always to descend in control, because loss of control may be difficult to recover;
- p) a caution that the descender device may become hot during or after a descent and may damage the line;
- q) a warning that the descender device is for rescue purposes only;
- r) for descender devices, class D, that after a single use they shall not be used again until confirmed safe to do so by the manufacturer or his authorised representative;
- s) number of this European Standard and its date of publication, i.e. EN 341:2011.
- t) for textile rope lines, information as required in EN 1891:1998, Clause 7 c) d) e) f) g) h) j)),

Annex A (informative)

Significant technical changes between this European Standard and EN 341:1992

Table A.1 — Significant technical changes

Clause / Paragraph / Table / Figure	Change
1 Scope	Scope has been modified: <ul style="list-style-type: none"> — the line is part of the descender device; — the descender device protects against falls in a rescue system; — the descender device is not intended to be used in mountaineering, rope access and work positioning systems.
2 Normative references	Updated
3 Terms, definitions and clauses	Definitions for “automatic descender device (type 1)”, “manually-operated descender device (type 2)”, “minimum rated load”, “maximum rated load”, “control device” and “panic locking element” have been incorporated.
4 Requirements	This clause has been re-structured.
4.1 General	Minimum and maximum rated load have been specified.
4.2 Design, materials and construction	Clause has been re-structured; connectors shall conform to EN 362; textile rope lines (of descender devices, class A, B or C) to EN 1891:1998, type A, 4.1 to 4.10.
4.2.2.4 Line integrity	This new requirement has been added.
4.3 Dynamic strength	This new requirement has been added.
4.4 Function	New requirements have been introduced for the use in cold respectively wet and cold conditions. A new requirement has been added for manually operated descender devices in a hands-off position or in case a panic locking element is engaged.
4.6 Static strength	New requirements, depending on the maximum rated load (class A, B and C) and/or the impact force in the dynamic strength test (class D) have been incorporated.
4.7 Corrosion resistance	A new requirement for corrosion resistance has been added.

Table A.1 (concluded)

Clause / Paragraph / Table / Figure		Change
4.8	Additional requirements for manually-operated descender devices (Type 2)	For ergonomic reasons, new requirements have been added for the holding force and the operating force.
4.9	Additional requirements for descender devices, class D	A new requirement has been added for descender devices class D to indicate whether they have been used.
4.10	Marking and information	This subclause has been added to the clause requirements.
5	Test methods	Clause has been re-structured. Sequence of the several tests has been added. New subclauses have been incorporated, in order to address new requirements.
5.1	Test samples	The number of provided test samples have been addressed
5.3	Dynamic strength test	New
5.4	Function tests	Re-structured, conditioning of samples has been modified, minimum and maximum rated load have been addressed.
5.5	Descent energy test	Minimum and maximum rated load have been addressed.
5.6	Static strength test	Test arrangements have been modified.
5.7	Operating force test	New
5.8	Holding force test	New
5.9	Line integrity test	New
5.10	Corrosion resistance test	New
6	Marking	Additional requirements for marking of the device have been added. Requirements for the marking of the lines have been introduced (manufacturer's logo and manufacturing year).
7	Information supplied by the manufacturer	Additional requirements have been added.
Figures 1 to 4		Four new figures for the description of the test procedures have been added.

British Standards Institution (BSI)

BSI is the national body responsible for preparing British Standards and other standards-related publications, information and services.

BSI is incorporated by Royal Charter. British Standards and other standardization products are published by BSI Standards Limited.

About us

We bring together business, industry, government, consumers, innovators and others to shape their combined experience and expertise into standards-based solutions.

The knowledge embodied in our standards has been carefully assembled in a dependable format and refined through our open consultation process. Organizations of all sizes and across all sectors choose standards to help them achieve their goals.

Information on standards

We can provide you with the knowledge that your organization needs to succeed. Find out more about British Standards by visiting our website at bsigroup.com/standards or contacting our Customer Services team or Knowledge Centre.

Buying standards

You can buy and download PDF versions of BSI publications, including British and adopted European and international standards, through our website at bsigroup.com/shop, where hard copies can also be purchased.

If you need international and foreign standards from other Standards Development Organizations, hard copies can be ordered from our Customer Services team.

Subscriptions

Our range of subscription services are designed to make using standards easier for you. For further information on our subscription products go to bsigroup.com/subscriptions.

With **British Standards Online (BSOL)** you'll have instant access to over 55,000 British and adopted European and international standards from your desktop. It's available 24/7 and is refreshed daily so you'll always be up to date.

You can keep in touch with standards developments and receive substantial discounts on the purchase price of standards, both in single copy and subscription format, by becoming a **BSI Subscribing Member**.

PLUS is an updating service exclusive to BSI Subscribing Members. You will automatically receive the latest hard copy of your standards when they're revised or replaced.

To find out more about becoming a BSI Subscribing Member and the benefits of membership, please visit bsigroup.com/shop.

With a **Multi-User Network Licence (MUNL)** you are able to host standards publications on your intranet. Licences can cover as few or as many users as you wish. With updates supplied as soon as they're available, you can be sure your documentation is current. For further information, email bsmusales@bsigroup.com.

BSI Group Headquarters

389 Chiswick High Road London W4 4AL UK

Revisions

Our British Standards and other publications are updated by amendment or revision.

We continually improve the quality of our products and services to benefit your business. If you find an inaccuracy or ambiguity within a British Standard or other BSI publication please inform the Knowledge Centre.

Copyright

All the data, software and documentation set out in all British Standards and other BSI publications are the property of and copyrighted by BSI, or some person or entity that owns copyright in the information used (such as the international standardization bodies) and has formally licensed such information to BSI for commercial publication and use. Except as permitted under the Copyright, Designs and Patents Act 1988 no extract may be reproduced, stored in a retrieval system or transmitted in any form or by any means – electronic, photocopying, recording or otherwise – without prior written permission from BSI. Details and advice can be obtained from the Copyright & Licensing Department.

Useful Contacts:

Customer Services

Tel: +44 845 086 9001

Email (orders): orders@bsigroup.com

Email (enquiries): cservices@bsigroup.com

Subscriptions

Tel: +44 845 086 9001

Email: subscriptions@bsigroup.com

Knowledge Centre

Tel: +44 20 8996 7004

Email: knowledgecentre@bsigroup.com

Copyright & Licensing

Tel: +44 20 8996 7070

Email: copyright@bsigroup.com



...making excellence a habit.™