

BS EN 196-2:2013



BSI Standards Publication

Method of testing cement

Part 2: Chemical analysis of cement

bsi.

...making excellence a habit.™

National foreword

This British Standard is the UK implementation of EN 196-2:2013. It supersedes BS EN 196-2:2005 which is withdrawn.

The UK participation in its preparation was entrusted to Technical Committee B/516/12, Sampling and testing.

A list of organizations represented on this committee can be obtained on request to its secretary.

This publication does not purport to include all the necessary provisions of a contract. Users are responsible for its correct application.

© The British Standards Institution 2013. Published by BSI Standards Limited 2013

ISBN 978 0 580 78941 0

ICS 91.100.10

Compliance with a British Standard cannot confer immunity from legal obligations.

This British Standard was published under the authority of the Standards Policy and Strategy Committee on 30 June 2013.

Amendments issued since publication

Date	Text affected
------	---------------

EUROPEAN STANDARD

EN 196-2

NORME EUROPÉENNE

EUROPÄISCHE NORM

June 2013

ICS 91.100.10

Supersedes EN 196-2:2005

English Version

Method of testing cement - Part 2: Chemical analysis of cementMéthodes d'essais des ciments - Partie 2: Analyse
chimique des cimentsPrüfverfahren für Zement - Teil 2: Chemische Analyse von
Zement

This European Standard was approved by CEN on 5 April 2013.

CEN members are bound to comply with the CEN/CENELEC Internal Regulations which stipulate the conditions for giving this European Standard the status of a national standard without any alteration. Up-to-date lists and bibliographical references concerning such national standards may be obtained on application to the CEN-CENELEC Management Centre or to any CEN member.

This European Standard exists in three official versions (English, French, German). A version in any other language made by translation under the responsibility of a CEN member into its own language and notified to the CEN-CENELEC Management Centre has the same status as the official versions.

CEN members are the national standards bodies of Austria, Belgium, Bulgaria, Croatia, Cyprus, Czech Republic, Denmark, Estonia, Finland, Former Yugoslav Republic of Macedonia, France, Germany, Greece, Hungary, Iceland, Ireland, Italy, Latvia, Lithuania, Luxembourg, Malta, Netherlands, Norway, Poland, Portugal, Romania, Slovakia, Slovenia, Spain, Sweden, Switzerland, Turkey and United Kingdom.

EUROPEAN COMMITTEE FOR STANDARDIZATION
COMITÉ EUROPÉEN DE NORMALISATION
EUROPÄISCHES KOMITEE FÜR NORMUNG**Management Centre: Avenue Marnix 17, B-1000 Brussels**

Contents

Page

Foreword.....	3
1 Scope	4
2 Normative references	4
3 General requirements for testing	4
3.1 Number of tests	4
3.2 Repeatability and reproducibility	5
3.3 Expression of masses, volumes, factors and results	5
4 Analysis by wet chemistry	5
4.1 General	5
4.2 Reagents	6
4.3 Apparatus	18
4.4 Analysis procedure	22
4.5 Determination of major elements	28
5 Chemical analysis by X-ray fluorescence	49
5.1 Reagents and reference materials	49
5.2 Apparatus	50
5.3 Flux	51
5.4 Determination of loss on ignition and the change in mass on fusion of the cement	53
5.5 Factoring test results and correcting total analyses for presence of sulfides and halides	54
5.6 Preparation of fused beads and pressed pellets	56
5.7 Calibration and validation	59
5.8 Calculation and expression of results	68
5.9 Performance criteria (repeatability, accuracy and reproducibility limits)	69
Annex A (informative) Examples of fluxes	70
Annex B (informative) Sources of certified reference materials	71
Annex C (informative) Examples of calibration standards and monitor beads and pellets	72
Bibliography	73

Foreword

This document (EN 196-2:2013) has been prepared by Technical Committee CEN/TC 51 “Cement and building limes”, the secretariat of which is held by NBN.

This European Standard shall be given the status of a national standard, either by publication of an identical text or by endorsement, at the latest by December 2013, and conflicting national standards shall be withdrawn at the latest by December 2013.

Attention is drawn to the possibility that some of the elements of this document may be the subject of patent rights. CEN [and/or CENELEC] shall not be held responsible for identifying any or all such patent rights.

This document supersedes EN 196-2:2005.

This edition adds, to the previous version EN 196-2:2005, provisions for the use of X-ray fluorescence (XRF) analysis as an alternative method. In relation to correctly calibrating the method, specified procedures, reference materials and performance criteria are included in order to attain and maintain suitable accuracy and precision for equivalence. The method has not been validated for use yet as a reference procedure for conformity or dispute purposes.

This European Standard on the methods of testing cement is comprised of the following parts:

- *Part 1: Determination of strength*
- *Part 2: Chemical analysis of cement*
- *Part 3: Determination of setting times and soundness*
- *Part 5: Pozzolanicity test for pozzolanic cement*
- *Part 6: Determination of fineness*
- *Part 7: Methods of taking and preparing samples of cement*
- *Part 8: Heat of hydration — Solution method*
- *Part 9: Heat of hydration — Semi-adiabatic method*
- *Part 10: Determination of the water-soluble chromium (VI) content of cement*

NOTE Another document, CEN/TR 196-4 *Methods of testing cement — Part 4: Quantitative determination of constituents*, has been published as a CEN Technical Report.

According to the CEN-CENELEC Internal Regulations, the national standards organisations of the following countries are bound to implement this European Standard: Austria, Belgium, Bulgaria, Croatia, Cyprus, Czech Republic, Denmark, Estonia, Finland, Former Yugoslav Republic of Macedonia, France, Germany, Greece, Hungary, Iceland, Ireland, Italy, Latvia, Lithuania, Luxembourg, Malta, Netherlands, Norway, Poland, Portugal, Romania, Slovakia, Slovenia, Spain, Sweden, Switzerland, Turkey and the United Kingdom.

1 Scope

This European Standard specifies the methods for the chemical analysis of cement.

This document describes the reference methods and, in certain cases, an alternative method which can be considered to be equivalent. In the case of a dispute, only the reference methods are used.

An alternative performance-based method using X-ray fluorescence (XRF) is described for SiO₂, Al₂O₃, Fe₂O₃, CaO, MgO, SO₃, K₂O, Na₂O, TiO₂, P₂O₅, Mn₂O₃, SrO, Cl and Br. When correctly calibrated according to the specified procedures and reference materials, it provides a method equivalent to the reference methods but has not been validated for use yet as a reference procedure for conformity and dispute purposes. It can be applied to other relevant elements when adequate calibrations have been established. This method is based on beads of fused sample and analytical validation using certified reference materials, together with performance criteria. A method based on pressed pellets of un-fused sample can be considered as equivalent, providing that the analytical performance satisfies the same criteria.

Any other methods may be used provided they are calibrated, either against the reference methods or against internationally accepted reference materials, in order to demonstrate their equivalence.

This document describes methods which apply principally to cements, but which can also be applied to their constituent materials. They can also be applied to other materials, the standards for which call up these methods. Standard specifications state which methods are to be used.

2 Normative references

The following documents, in whole or in part, are normatively referenced in this document and are indispensable for its application. For dated references, only the edition cited applies. For undated references, the latest edition of the referenced document (including any amendments) applies.

EN 196-7, *Methods of testing cement — Part 7: Methods of taking and preparing samples of cement*

ISO 385, *Laboratory glassware — Burettes*

ISO 835, *Laboratory glassware — Graduated pipettes*

ISO Guide 30, *Terms and definitions used in connection with reference materials*

ISO Guide 31, *Reference materials — Contents of certificates and labels*

3 General requirements for testing

3.1 Number of tests

Analysis of a cement may require the determination of a number of its chemical properties. For each determination, one or more tests shall be carried out in which the number of measurements to be taken shall be as specified in the relevant clause of this document.

Where the analysis is one of a series subject to statistical control, the determination of each chemical property by a single test shall be the minimum required.

Where the analysis is not part of a series subject to statistical control, the number of tests for determination of each chemical property shall be two (see also 3.3 and 5.8).

In the case of a dispute, the number of tests for determination of each chemical property shall be two (see also 3.3).

3.2 Repeatability and reproducibility

Repeatability: Precision under repeatability conditions where independent test results are obtained with the same method on identical test items (material) in the same laboratory by the same operator using the same equipment within short intervals of time.

Reproducibility: Precision under reproducibility conditions where test results are obtained with the same method on identical test items (material) in different laboratories with different operators using different equipment.

Repeatability and reproducibility in this document are expressed as repeatability standard deviation(s) and reproducibility standard deviation(s) in e.g. absolute percent, grams, etc., according to the property tested.

3.3 Expression of masses, volumes, factors and results

Express masses in grams to the nearest 0,000 1 g and volumes from burettes in millilitres to the nearest 0,05 ml.

Express the factors of solutions, given by the mean of three measurements, to three decimal places.

Express the results, where a single test result has been obtained, as a percentage generally to two decimal places.

Express the results, where two test results have been obtained, as the mean of the results, as a percentage generally to two decimal places.

If the two test results differ by more than twice the standard deviation of repeatability, repeat the test and take the mean of the two closest test results.

The results of all individual tests shall be recorded.

4 Analysis by wet chemistry

4.1 General

4.1.1 Ignitions

Carry out ignitions as follows.

Place the filter paper and its contents into a crucible which has been previously ignited and tared. Dry it, then incinerate slowly in an oxidising atmosphere in order to avoid immediate flaming, while ensuring complete combustion. Ignite the crucible and its contents at the stated temperature then allow to cool to the laboratory temperature in a desiccator. Weigh the crucible and its contents.

4.1.2 Determination of constant mass

Determine constant mass by making successive 15 min ignitions followed each time by cooling and then weighing. Constant mass is reached when the difference between two successive weighings is less than 0,000 5 g.

4.1.3 Check for absence of chloride ions (silver nitrate test)

After generally five to six washes of a precipitate, rinse the base of the filter stem with a few drops of water. Wash the filter paper and its contents with several millilitres of water and collect this in a test tube. Add several drops of silver nitrate solution (4.2.44). Check the absence of turbidity or precipitate in the solution. If present, continue washing while carrying out periodic checks until the silver nitrate test is negative.

4.1.4 Blank determinations

Carry out a blank determination without a sample, where relevant, following the same procedure and using the same amounts of reagents. Correct the results obtained for the analytical determination accordingly.

4.1.5 Preparation of a test sample of cement

Before chemical analysis, treat the laboratory sample, taken in accordance with EN 196-7, as follows to obtain a homogeneous test sample.

Take approximately 100 g of the laboratory sample by means of a sample divider or by quartering. Sieve this portion on a 150 µm or 125 µm sieve until the residue remains constant. Remove metallic iron from the material retained on the sieve by means of a magnet (see Note 1). Then grind the iron-free fraction of the retained material so that it completely passes the 150 µm or 125 µm sieve. Transfer the sample to a clean dry container with an airtight closure and shake vigorously to mix it thoroughly.

Carry out all operations as quickly as possible to ensure that the test sample is exposed to ambient air only for the minimum time.

NOTE 1 Where the analysis is one of a series subject to statistical control and the level of the metallic iron content has been shown to be insignificant in relation to the chemical properties to be determined then it is not necessary to remove metallic iron.

NOTE 2 Where the sample is to be used for XRF analysis and it contains quartz, it might be necessary to grind the sample to pass a 90 µm sieve in order to obtain a satisfactory fusion (see 5.6). The time and temperature required to obtain a satisfactory fusion is affected by the fineness of the sample.

NOTE 3 Where the sample is to be used for XRF analysis using pressed pellets, accuracy can be improved by grinding the sample more finely.

4.2 Reagents

4.2.1 General

Use only reagents of analytical quality. References to water mean distilled or de-ionised water having an electrical conductivity $\leq 0,5$ mS/m.

Unless otherwise stated, percent means percent by mass.

Unless otherwise stated, the concentrated liquid reagents used in this document have the following densities (ρ) (in g/cm³ at 20 °C):

hydrochloric acid	1,18 to 1,19	acetic acid	1,05 to 1,06
nitric acid	1,40 to 1,42	phosphoric acid	1,71 to 1,75
perchloric acid	1,60 to 1,67	ammonium hydroxide	0,88 to 0,91

The degree of dilution is always given as a volumetric sum, for example: dilute hydrochloric acid 1 + 2 means that 1 volume of concentrated hydrochloric acid is to be mixed with 2 volumes of water.

4.2.2 Concentrated hydrochloric acid (HCl)

4.2.3 Dilute hydrochloric acid (1 + 1)

4.2.4 Dilute hydrochloric acid (1 + 2)

4.2.5 Dilute hydrochloric acid (1 + 3)

4.2.6 Dilute hydrochloric acid (1 + 9)

4.2.7 Dilute hydrochloric acid (1 + 11)

4.2.8 Dilute hydrochloric acid (1 + 19)

4.2.9 Dilute hydrochloric acid (1 + 99)

4.2.10 Dilute hydrochloric acid of pH (1,60 ± 0,05)

Prepare by adjusting the pH of two litres of water to (1,60 ± 0,05) by adding five or six drops of concentrated hydrochloric acid. Control using the pH meter (4.3.18.1). Store the solution in a polyethylene container.

4.2.11 Concentrated hydrofluoric acid (> 40 %) (HF)

4.2.12 Dilute hydrofluoric acid (1 + 3)

4.2.13 Concentrated nitric acid (HNO₃)

4.2.14 Dilute nitric acid (1 + 2)

4.2.15 Dilute nitric acid (1 + 100)

4.2.16 Concentrated sulfuric acid (>98 %) (H₂SO₄)

4.2.17 Dilute sulfuric acid (1 + 1)

4.2.18 Dilute sulfuric acid (1 + 4)

4.2.19 Concentrated perchloric acid (HClO₄)

4.2.20 Concentrated phosphoric acid (H₃PO₄)

4.2.21 Dilute phosphoric acid (1 + 19)

Store this solution in a polyethylene container.

4.2.22 Boric acid (H₃BO₃)

4.2.23 Concentrated acetic acid (CH₃COOH)

4.2.24 Amino-acetic acid (NH₂CH₂COOH)

4.2.25 Metallic chromium (Cr), in powder form

4.2.26 Concentrated ammonium hydroxide (NH₄OH)

4.2.27 Dilute ammonium hydroxide (1 + 1)

4.2.28 Dilute ammonium hydroxide (1 + 10)

4.2.29 Dilute ammonium hydroxide (1 + 16)

4.2.30 Sodium hydroxide (NaOH)

4.2.31 Sodium hydroxide solution (4 mol/l)

Dissolve 160 g of sodium hydroxide (4.2.30) in water and make up to 1 000 ml. Store in a polyethylene container.

4.2.32 Sodium hydroxide solution (2 mol/l)

Dissolve 80 g of sodium hydroxide (4.2.30) in water and make up to 1 000 ml. Store in a polyethylene container.

4.2.33 Ammonium chloride (NH₄Cl)

4.2.34 Tin (II) chloride (SnCl₂·2H₂O)

4.2.35 Potassium iodate (KIO₃) dried to constant mass at (120 ± 5) °C

4.2.36 Potassium periodate (KIO₄)

4.2.37 Sodium peroxide (Na₂O₂) in powder form

4.2.38 Sodium chloride (NaCl) dried to constant mass at (110 ± 5) °C

4.2.39 Potassium chloride (KCl) dried to constant mass at (110 ± 5) °C

4.2.40 Sodium carbonate (Na₂CO₃) dried to constant mass at (250 ± 10) °C

4.2.41 Mixture of sodium carbonate and sodium chloride

Mix 7 g of sodium carbonate (4.2.40) with 1 g sodium chloride (NaCl) (4.2.38).

4.2.42 Barium chloride solution

Dissolve 120 g of barium chloride (BaCl₂·2H₂O) in water and make up to 1 000 ml.

4.2.43 Silver nitrate (AgNO₃) dried to constant mass at (150 ± 5) °C

4.2.44 Silver nitrate solution

Dissolve 5 g of silver nitrate (AgNO₃) (4.2.43) in water, add 10 ml of concentrated nitric acid (HNO₃) (4.2.14) and make up to 1 000 ml with water.

4.2.45 Silver nitrate solution (0,05 mol/l)

Dissolve (8,494 0 ± 0,000 5) g of silver nitrate (AgNO₃) (4.2.43) in water in a 1 000 ml volumetric flask and make up to the mark. Store in a brown glass container and protect from the light.

4.2.46 Sodium carbonate solution

Dissolve 50 g of anhydrous sodium carbonate (4.2.40) in water and make up to 1 000 ml.

4.2.47 Potassium hydroxide solution

Dissolve 250 g of potassium hydroxide (KOH) in water and make up to 1 000 ml. Store in a polyethylene container.

4.2.48 Ammoniacal zinc sulfate solution

Dissolve 50 g of zinc sulfate ($\text{ZnSO}_4 \cdot 7\text{H}_2\text{O}$) in 150 ml water and add 350 ml of concentrated ammonium hydroxide (4.2.26). Leave to stand for at least 24 h and filter.

4.2.49 Lead acetate solution

Dissolve approximately 0,2 g of lead acetate ($\text{Pb}(\text{CH}_3\text{COO})_2 \cdot 3\text{H}_2\text{O}$) in water and make up to 100 ml.

4.2.50 Starch solution

To 1 g of starch (water soluble), add 1g of potassium iodide (KI), dissolve in water and make up to 100 ml. Use within two weeks.

4.2.51 Polyethylene oxide solution

Dissolve 0,25 g of polyethylene oxide ($-\text{CH}_2-\text{CH}_2-\text{O}-$)_n of average molecular mass 200 000 to 600 000, in 100 ml water while stirring vigorously. Use within two weeks.

4.2.52 Boric acid solution, saturated

Dissolve approximately 50 g of boric acid (H_3BO_3) in water and make up to 1 000 ml.

4.2.53 Citric acid solution

Dissolve 10 g of citric acid ($\text{C}_6\text{H}_8\text{O}_7 \cdot \text{H}_2\text{O}$) in water and make up to 100 ml.

4.2.54 Calcium carbonate (CaCO_3) dried to constant mass at $(200 \pm 10)^\circ\text{C}$ (of purity > 99,9 %)

4.2.55 Ammonium molybdate solution

Dissolve 10 g of ammonium molybdate ($(\text{NH}_4)_6\text{Mo}_7\text{O}_{24} \cdot 4\text{H}_2\text{O}$) in water and make up to 100 ml. Store the solution in a polyethylene flask. Use within one week.

4.2.56 Copper sulfate solution

Dissolve 0,45 g of copper sulfate ($\text{CuSO}_4 \cdot 5\text{H}_2\text{O}$) in water and make up to 50 ml in a volumetric flask.

4.2.57 Ammonium acetate solution

Dissolve 250 g of ammonium acetate ($\text{CH}_3\text{COONH}_4$) in water and make up to 1 000 ml.

4.2.58 Triethanolamine [$N(CH_2CH_2OH)_3$], (>99 %) diluted to 1 + 4 solution

4.2.59 Reducing solution

Dissolve 1 g of tin (II) chloride ($SnCl_2 \cdot 2H_2O$) (4.2.34) in water to which has been added 1 ml of concentrated hydrochloric acid (4.2.2). Make up to 100 ml with water. Use within one day.

4.2.60 Buffer solution of pH 1,40

Dissolve $(7,505 \pm 0,001)$ g of amino-acetic acid (4.2.24) and $(5,850 \pm 0,001)$ g of sodium chloride (NaCl) (4.2.38) in water and make up to 1 000 ml. Dilute 300 ml of this solution to 1 000 ml with hydrochloric acid 1 + 99 (4.2.9).

4.2.61 Standard potassium iodate solution, approximately 0,016 6 mol/l

Weigh, to $\pm 0,000 5$ g, $(3,6 \pm 0,1)$ g, of potassium iodate (KIO_3) (4.2.35) (m_1) and place in a 1 000 ml volumetric flask. Add 0,2 g of sodium hydroxide (4.2.30), 25 g of potassium iodide (KI), dissolve all the solids in freshly boiled and cooled water and make up to the mark using the same water.

Calculate the factor F of the potassium iodate solution from the following formula:

$$F = \frac{m_1}{3,5668} \quad (1)$$

where

m_1 is the mass of the portion of potassium iodate, in grams.

4.2.62 Sodium thiosulfate solution, approximately 0,1 mol/l

4.2.62.1 Preparation

Dissolve $(24,82 \pm 0,01)$ g of sodium thiosulfate ($Na_2S_2O_3 \cdot 5H_2O$) in water and make up to 1 000 ml. Before each test series, determine the factor f of this solution as described in 4.2.62.2.

4.2.62.2 Standardization

4.2.62.2.1 Standardization using potassium iodate solution

This standardization is carried out preferably using the standard potassium iodate solution (4.2.61). For this standardization, pipette 20 ml of the standard potassium iodate solution (4.2.61) into a 500 ml conical flask and dilute with approximately 150 ml of water. Acidify with 25 ml of hydrochloric acid 1+1 (4.2.3) and titrate with the approximately 0,1 mol/l sodium thiosulfate solution (4.2.62.1) to a pale yellow colour. Add 2 ml of the starch solution (4.2.50) and continue the titration until the colour changes from blue to colourless.

Calculate the factor f of the sodium thiosulfate solution from the formula:

$$f = \frac{20 \times 0,01667 \times 214,01 \times F}{3,5668 \times V_1} = 20 \times \frac{F}{V_1} \quad (2)$$

where

F is the factor of the standard potassium iodate solution (4.2.61);

V_1 is the volume of the approximately 0,1 mol/l sodium thiosulfate solution used for the titration, in millilitres;

3,566 8 is the mass of potassium iodate corresponding to a solution with exactly 0,016 67 mol/l of potassium iodate, in grams;

214,01 is the molecular mass of KIO_3 , in grams.

4.2.62.2 Standardisation using a known quantity of potassium iodate

The standardization may alternatively be carried out using a known quantity of potassium iodate. For this standardization, weigh, to $\pm 0,000 5$ g, ($0,070 \pm 0,005$) g of potassium iodate (4.2.35) (m_2) and place in a 500 ml conical flask. Dissolve in approximately 150 ml of water. Add about 1 g of potassium iodide, acidify with 25 ml of hydrochloric acid 1+1 (4.2.3) and titrate with the approximately 0,1 mol/l sodium thiosulfate solution (4.2.62.1) until a pale yellow colour is obtained. Then add 2 ml of the starch solution (4.2.50) and titrate until the colour changes from blue to colourless.

Calculate the factor f of the sodium thiosulfate solution from the formula:

$$f = \frac{1000 \times m_2}{3,5668 \times V_2} = 280,3634 \times \frac{m_2}{V_2} \quad (3)$$

where

m_2 is the mass of potassium iodate, in grams;

V_2 is the volume of the approximately 0,1 mol/l sodium thiosulfate solution used for the titration, in millilitres;

3,566 8 is the mass of potassium iodate corresponding to a solution with exactly 0,016 67 mol/l of potassium iodate, in grams.

4.2.63 Standard manganese solution

4.2.63.1 Anhydrous manganese sulfate

Dry hydrated manganese sulfate ($\text{MnSO}_4 \cdot x\text{H}_2\text{O}$) to constant mass at (250 ± 10) °C. The composition of the product obtained corresponds to the formula MnSO_4 .

4.2.63.2 Preparation

Into a 1 000 ml volumetric flask, weigh, to $\pm 0,000 5$ g, ($2,75 \pm 0,05$) g of anhydrous manganese sulfate (m_3); dissolve in water and make up to the mark. Calculate the content G of manganese (II) ions of this solution, expressed in milligrams of Mn^{2+} per millilitre, from the formula:

$$G = \frac{m_3}{2,7485} \quad (4)$$

where

m_3 is the mass of anhydrous manganese sulfate, in grams.

4.2.63.3 Construction of the calibration curve

Into each of two volumetric flasks, respectively 500 ml (No. 1) and 1 000 ml (No. 2), pipette 20 ml of the standard manganese solution. Make up to the mark with water. Into each of three volumetric flasks, respectively 200 ml (No. 3), 500 ml (No. 4) and 1 000 ml (No. 5) pipette 100 ml of the solution from flask No. 2 and make up to the mark with water.

Take 100 ml of each solution from flasks 1 to 5 and pipette each portion into a 400 ml beaker. Add 20 ml of concentrated nitric acid (4.2.13), 1,5 g of potassium periodate (4.2.36) and 10 ml of phosphoric acid (4.2.20), heat to boiling and boil gently for 30 min.

Allow to cool to room temperature and transfer the contents of each beaker to a 200 ml volumetric flask and make up to the mark with water. Measure the absorbance of the solutions using a photometer (4.3.10) at a wavelength of around 525 nm, against water (use one or more cells (4.3.11) of appropriate sizes). Record the absorbance values to three decimal places.

For each cell optical length, construct a separate curve of the absorbance of these calibration solutions E1 to E5 as a function of the corresponding manganese concentrations in milligrams of Mn per 200 ml. The corresponding manganese concentrations are given in Table 1. They can be used as given if the content G obtained in accordance with 4.2.63.2 has the value 1,000 0. Otherwise, multiply the manganese concentrations in Table 1 by the value of G calculated from Formula (4).

Table 1 — Concentrations of manganese calibration solutions

Calibration solution	E1	E2	E3	E4	E5
Concentration of manganese in mg of Mn per 200 ml	4,0	2,0	1,0	0,4	0,2

4.2.64 Standard silica solution

4.2.64.1 Silica (SiO₂), of purity >99,9 % after ignition to constant mass at (1 175 ± 25) °C.

4.2.64.2 Basic solution

Weigh (0,200 0 ± 0,000 5) g of freshly ignited silica (4.2.64.1), in a platinum crucible already containing (2,0 ± 0,1) g of anhydrous sodium carbonate (4.2.40).

Heat the mixture and fuse it at a bright-red heat for at least 15 min. After cooling to room temperature, place the fused solid in a polyethylene beaker and dissolve it in water, then transfer the solution quantitatively to a 200 ml volumetric flask and make up to the mark with water.

Store the solution in a polyethylene container.

This solution contains 1 mg of SiO₂ per millilitre.

4.2.64.3 Standard solution

Pipette 5 ml of the basic solution into a 250 ml volumetric flask and make up to the mark with water. Store the solution in a polyethylene container. This solution contains 0,02 mg silica per millilitre. Use within one week.

4.2.64.4 Compensating solutions

Prepare the compensating solutions according to the procedure adopted in the determination of silica content (4.5.3 to 4.5.5) by dissolving the amounts of the reagents given in Table 2 in water and making up to 500 ml.

4.2.64.5 Construction of the calibration curve

Add from a burette the volumes of the silica calibration solutions given in Table 3 into 100 ml polyethylene beakers each containing a magnetic stirrer bar. Add 20 ml of the compensating solution by pipette and make up to 40 ml with water from a burette. The volumes required for this are also given in Table 3. While stirring with a magnetic stirrer, add 15 drops of hydrofluoric acid 1+3 (4.2.12). Stir for at least 1 min. Then pipette 15 ml of the boric acid solution (4.2.52) into the solution.

Table 2 — Composition of the compensating solutions for a volume of 500 ml

	Precipitation by double evaporation (4.5.3)	Precipitation by polyethylene oxide (4.5.4)	Decomposition by HCl and NH ₄ Cl (4.5.5)
HCl conc. ml	75	70	15
H ₂ SO ₄ 1 + 1 ml	1	1	-
HNO ₃ conc. ml	-	-	1
Polyethylene oxide solution ml	-	5	-
NH ₄ Cl g	-	-	1
Na ₂ CO ₃ g	1,75	1,75	1,75
NaCl g	0,25	0,25	0,25
Na ₂ O ₂ g	3	3	-

Table 3 — Composition of the silica calibration solutions and their silica content

Serial No.	Blank	1	2	3	4
Standard SiO ₂ solution (ml)	0	2	5	10	20
Water (ml)	20	18	15	10	0
Silica content (mg SiO ₂ /100 ml)	0	0,04	0,10	0,20	0,40

Add from a pipette 5 ml of the ammonium molybdate solution (4.2.55). Adjust the pH of this solution to $(1,60 \pm 0,05)$ by adding, drop by drop, sodium hydroxide solution (4.2.31) or hydrochloric acid 1 + 2 (4.2.4) using the pH meter (4.3.18.1) calibrated with a buffer solution of similar pH (e.g. 1,40 see 4.2.60). Transfer the solution to a 100 ml volumetric flask and rinse the beaker with dilute hydrochloric acid (4.2.10). After 20 min, add from a pipette 5 ml of the citric acid solution (4.2.53), stir and leave to stand for 5 min. Then add from a pipette 2 ml of the reducing solution (4.2.59). (Time 0).

Make up to the mark with dilute hydrochloric acid (4.2.10) and mix. At time $(0 + 30)$ min, measure the absorbance with the photometer (4.3.10) using a cell (4.3.11) of 1 cm optical length against the blank solution prepared in the same way, using the wavelength 815 nm. Construct a curve giving the measured absorbance as a function of the corresponding silica contents given in Table 3.

The blank solution used in constructing the calibration curve may be used as the blank solution here. The calibration curve enables the silica content in mg SiO₂/100 ml to be determined.

4.2.65 Standard calcium ion solution, approximately 0,01 mol/l

Weigh, to $\pm 0,0005$ g, $(1,00 \pm 0,01)$ g of calcium carbonate (4.2.54) (m_4) and place it in a 400 ml beaker with approximately 100 ml of water. Cover the beaker with a watch glass and carefully introduce approximately 10 ml of hydrochloric acid 1 + 2 (4.2.4). Stir with a glass rod and ensure that dissolution is complete, bring to the boil in order to expel the dissolved carbon dioxide. Cool to room temperature, transfer to a 1 000 ml volumetric flask, washing the beaker and watch glass carefully, and make up to the mark with water.

4.2.66 EDTA solution, approximately 0,03 mol/l

4.2.66.1 Ethylenediaminetetra-acetic acid disodium salt dihydrate (EDTA)

4.2.66.2 Preparation

Dissolve $(11,17 \pm 0,01)$ g of EDTA in water and make up to 1 000 ml. Store in a polyethylene container.

4.2.66.3 Standardization

Pipette 50 ml of the standard calcium ion solution (4.2.65) into a beaker suitable for the measuring apparatus (4.3.12). Then dilute with water to a volume suitable for the operation of the apparatus.

Using the pH meter (4.3.18.1), adjust the pH of this solution to $(12,5 \pm 0,2)$ with either of the sodium hydroxide solutions (4.2.31 or 4.2.32).

Determine the end-point using one of the following two methods.

a) Photometric determination of the end-point (reference method)

Add, without weighing, about 0,1 g of murexide (4.2.70) or of mixed calcein and methylthymol blue indicator (4.2.76). Place the beaker in the apparatus (4.3.12) set at 620 nm when using murexide or at 520 nm when using the mixed indicator and, while stirring continuously, titrate with the approximately 0,03 mol/l EDTA solution. In the vicinity of the indicator colour change, construct a curve giving the absorbance values as a function of the volume of EDTA added. The volume V_3 used is determined from the intersection of the line of greatest slope near the colour change and the line of almost constant absorbance after the colour change.

Calculate the factor f_D of the EDTA solution from the formula:

$$f_D = \frac{50 \times m_4}{100,09 \times 0,03 \times V_3} = 16,652 \times \frac{m_4}{V_3} \quad (5)$$

where

m_4 is the mass of calcium carbonate taken to prepare the standard calcium ion solution (4.2.65), in grams;

V_3 is the volume of the EDTA solution used for the titration, in millilitres.

b) Visual determination of the end-point (alternative method)

Add, without weighing, about 0,1 g of either the calcon indicator (4.2.72) or the Patton and Reeders indicator (4.2.77). Stir and titrate with the approximately 0,03 mol/l EDTA solution (4.2.66) until the colour changes from pink to blue (calcon) or purple to blue (Patton and Reeders), volume V_3 , and one drop in excess does not further increase the intensity of the blue colour. Calculate the standardization factor f_D of the EDTA solution using Formula (5).

4.2.67 Copper complexonate solution

Pipette 25 ml of the copper sulfate solution (4.2.56) into a 400 ml beaker and add from a burette an equivalent volume V_5 of the approximately 0,03 mol/l EDTA solution (4.2.66). Determine the required volume V_5 of EDTA solution as follows.

Pipette 10 ml of the copper sulfate solution (4.2.56) into a 600 ml beaker. Dilute to approximately 200 ml with water and add 10 ml of concentrated ammonium hydroxide (4.2.26) and, without weighing, about 0,1 g of murexide indicator (4.2.70). Titrate with the approximately 0,03 mol/l EDTA solution (4.2.66) until the colour changes from pink to violet (V_4).

Calculate the volume V_5 of the approximately 0,03 mol/l EDTA solution to be added to 25 ml of the copper sulfate solution to obtain copper complexonate from the formula:

$$V_5 = 2,5 \times V_4 \quad (6)$$

where

V_4 is the volume of the approximately 0,03 mol/l EDTA solution for the titration, in millilitres.

4.2.68 EGTA solution, approximately 0,03 mol/l

4.2.68.1 Ethyleneglycolbis (aminoethylether) tetra-acetic acid (EGTA)

4.2.68.2 Preparation

Dissolve (11,4 ± 0,01) g of EGTA in 400 ml of water and 30 ml of the sodium hydroxide solution (4.2.32) in a 600 ml beaker. Heat the mixture until the EGTA is completely dissolved. Allow to cool to room temperature. Using the pH meter (4.3.18.1), adjust the pH to (7,0 ± 0,5), by adding, drop by drop, hydrochloric acid 1 + 2 (4.2.4). Transfer the solution quantitatively to a 1 000 ml volumetric flask and make up to the mark with water. Store the solution in a polyethylene container.

4.2.68.3 Standardization

Pipette 50 ml of the standard calcium ion solution (4.2.65) into a beaker suitable for the measuring apparatus (4.3.12). Then dilute with water to a volume suitable for the correct operation of the apparatus. Add 25 ml of the triethanolamine 1 + 4 solution (4.2.58).

Using the pH meter (4.3.18.1), adjust the pH of this solution to (12,5 ± 0,2) with either of the sodium hydroxide solutions (4.2.31 or 4.2.32).

Add, without weighing, about 0,1 g of murexide (4.2.70) or of calcein indicator (4.2.71). Place the beaker in the apparatus (4.3.12) set at 620 nm when using murexide or at 520 nm when using calcein and, while stirring continuously, titrate with the approximately 0,03 mol/l EGTA solution. In the vicinity of the indicator colour change, take note of the absorbance values and the correspondent volumes of EGTA added and construct a curve of absorbance versus volume of titrant. The volume V_6 used is determined from the intersection of the line of greatest slope near the colour change and the line of almost constant absorbance after the colour change.

Calculate the factor f_G of the EGTA solution from the formula:

$$f_G = \frac{50 \times m_5}{100,09 \times 0,03 \times V_6} = 16,652 \times \frac{m_5}{V_6} \quad (7)$$

where

m_5 is the mass of calcium carbonate taken to prepare the standard calcium ion solution (4.2.65), in grams;

V_6 is the volume of the EGTA solution used for the titration, in millilitres.

4.2.69 DCTA solution, approximately 0,01 mol/l

4.2.69.1 1,2-diaminocyclohexane tetra-acetic (DCTA)

4.2.69.2 Preparation

Dissolve (3,64 ± 0,01) g of DCTA in about 400 ml of water and 10 ml of sodium hydroxide solution (4.2.32) in a 600 ml beaker. Heat the mixture until the DCTA is completely dissolved. Allow to cool to room temperature. Using the pH meter (4.3.18.1), adjust the pH to (7,0 ± 0,5) by adding hydrochloric acid 1 + 2 (4.2.4), drop by drop. Transfer the solution quantitatively to a 1 000 ml volumetric flask and make up to the mark with water. Store this solution in a polyethylene container.

4.2.69.3 Standardization

Pipette 50 ml of the standard calcium ion solution (4.2.65) into a beaker appropriate for the measuring apparatus (4.3.12). Then dilute with water to a volume suitable for the correct operation of the apparatus.

Using the pH meter (4.3.18.1), adjust the pH of this solution to $(10,5 \pm 0,2)$ with concentrated ammonium hydroxide (4.2.26).

Add, without weighing, about 0,1 g of murexide (4.2.70) or of calcein indicator (4.2.71). Place the beaker in the apparatus (4.3.12) set at 620 nm when using murexide or at 520 nm when using calcein and, while continuously stirring the solution, titrate with the approximately 0,01 mol/l DCTA solution. In the vicinity of the colour change of the indicator, take note of the absorbance values and the correspondent volumes of DCTA added and construct a curve of absorbance versus volume of titrant. The volume V_7 used is determined by the intersection of the line of greatest slope near the colour change and the line of almost constant absorbance after the colour change.

Calculate the factor f_c of the DCTA solution from the formula:

$$f_c = \frac{50 \times m_6}{100,09 \times 0,01 \times V_7} = 49,955 \times \frac{m_6}{V_7} \quad (8)$$

where

m_6 is the mass of calcium carbonate taken to prepare the standard calcium ion solution (4.2.65), in grams;

V_7 is the volume of the DCTA solution used for the titration, in millilitres.

4.2.70 Murexide indicator

Prepare by grinding $(1,0 \pm 0,1)$ g of murexide (ammonium purpurate, $C_8H_4N_5O_6 \cdot NH_4$) with (100 ± 1) g of sodium chloride (NaCl).

4.2.71 Calcein indicator

Prepare by grinding $(1,0 \pm 0,1)$ g of calcein (bis [(bis (carboxymethyl)-amino-methyl)] -2', 7'-fluorescein, Fluoresceindi-(methylimino diacetic acid) sodium salt) with (100 ± 1) g of potassium nitrate (KNO_3).

4.2.72 Calcon indicator

Prepare by grinding $(1,0 \pm 0,1)$ g of calcon (sodium 2-hydroxy-4-(2-hydroxy-1-naphthylazo) naphthalene-1-sulfonate, EriochromeBlue-Black R) with (100 ± 1) g of anhydrous sodium sulfate (Na_2SO_4).

4.2.73 Sulfosalicylic acid indicator (5-sulfosalicylic acid dihydrate)

4.2.74 PAN indicator

Prepare by dissolving $(0,10 \pm 0,01)$ g of PAN (1-(2-pyridylazo)-2-naphthol, $C_{15}H_{11}N_3O$) in (100 ± 1) ml ethanol (C_2H_5OH , density = 0,79).

4.2.75 Methylthymol blue indicator

Prepare by grinding $(1,0 \pm 0,1)$ g of methylthymol blue (sodium salt of 3', 3''-bis- [bis (carboxy-methyl)-aminomethyl]-thymolsulfophthalein, $C_{37}H_{41}N_2O_{13}SNa_3$) with (100 ± 1) g of potassium nitrate (KNO_3).

4.2.76 Mixed calcein and methylthymol blue indicator

Prepare by grinding $(0,20 \pm 0,02)$ g of calcein (see 4.2.71) and $(0,10 \pm 0,01)$ g of methylthymol blue (see 4.2.75) with (100 ± 1) g of potassium nitrate (KNO_3).

4.2.77 Patton and Reeders reagent

Prepare by mixing $(1,0 \pm 0,1)$ g of 2-hydroxy-1-(2-hydroxy-4-sulfo-1-naphthylazo)-3-naphthoic acid ($\text{C}_{21}\text{H}_{14}\text{N}_2\text{O}_7\text{S}$) with (100 ± 1) g of anhydrous sodium sulfate (Na_2SO_4).

4.2.78 Mixed indicator

Prepare by mixing $(0,10 \pm 0,01)$ g *o*-cresolphthalein complexone (*o*-cresolphthaleindi-(methyliminodi-acetic acid), $\text{C}_{32}\text{H}_{32}\text{N}_2\text{O}_{12}$), $(0,020 \pm 0,001)$ g methyl red indicator (*o*-carboxybenzene-azodimethyl-aniline, $\text{C}_{15}\text{H}_{14}\text{N}_3\text{NaO}_2$) and $(0,030 \pm 0,001)$ g naphthol green B ($\text{C}_{30}\text{H}_{15}\text{FeN}_3\text{Na}_3\text{O}_{15}\text{S}_3$) with $(10,0 \pm 0,1)$ g of sodium chloride (4.2.38).

4.2.79 Ammonium thiocyanate (NH_4SCN)

4.2.80 Ammonium thiocyanate solution, approximately 0,05 mol/l

Prepare by dissolving $(3,8 \pm 0,1)$ g of ammonium thiocyanate (4.2.79) in water and making up to 1 000 ml.

4.2.81 Ammonium iron (III) sulfate, ($\text{NH}_4\text{Fe}(\text{SO}_4)_2 \cdot 12\text{H}_2\text{O}$)

4.2.82 Indicator solution

Prepare by adding 10 ml of nitric acid 1 + 2 (4.2.14) to 100 ml of a cold saturated water solution of ammonium iron (III) sulfate (4.2.81).

4.2.83 Copper (II) sulfate ($\text{CuSO}_4 \cdot 5\text{H}_2\text{O}$)

4.2.84 Saturated water solution of copper (II) sulfate

4.2.85 Absorbent for hydrogen sulfide

Place a weighed quantity of dried pumice stone with a grain size between 1,2 mm and 2,4 mm into a flat dish and cover with a volume of saturated copper sulfate solution (4.2.84) so the mass of the copper sulfate solution is approximately half of that of the pumice stone. Evaporate the mixture to dryness, while stirring frequently with a glass rod. Dry the contents of the dish for at least 5 h in an oven at a temperature of (150 ± 5) °C. Allow the solid mixture to cool in a desiccator and store in an airtight bottle.

4.2.86 Absorbent for water

Anhydrous magnesium perchlorate ($\text{Mg}(\text{ClO}_4)_2$) with a particle size between 0,6 mm and 1,2 mm.

4.2.87 Absorbent for carbon dioxide

Synthetic silicates with a particle size between 0,6 mm to 1,2 mm impregnated with sodium hydroxide (NaOH) (4.2.30).

NOTE This absorbent can be obtained ready for use.

4.2.88 Mercuric (II) chloride (HgCl_2)

4.2.89 Alkali stock solution

Weigh $(0,566\ 0 \pm 0,000\ 5)$ g of sodium chloride (4.2.38) and $(0,475\ 0 \pm 0,000\ 5)$ g of potassium chloride (4.2.39) and place in a 600 ml beaker. Add approximately 150 ml of water and allow the salts to dissolve. Transfer the solution quantitatively, rinsing the beaker with water, to a 1 000 ml volumetric flask and make up to the mark with water. Mix the contents of the flask thoroughly. This solution contains 0,300 g each of sodium oxide (Na_2O) and potassium oxide (K_2O).

4.2.90 Acid stock solution, ($\text{HCl}/\text{H}_3\text{PO}_4$)

To approximately 500 ml of water, placed in a 1 000 ml volumetric flask, add 50 ml of concentrated hydrochloric acid (4.2.2) and 50 ml of concentrated phosphoric acid (4.2.20). Allow to cool then make up to the mark with water and mix thoroughly.

4.2.91 Calcium stock solution

Weigh $(11,25 \pm 0,01)$ g of calcium carbonate (4.2.54) into a 600 ml beaker. Add 100 ml of water and dissolve the calcium carbonate by cautiously adding 25 ml of concentrated hydrochloric acid (4.2.2). After the reaction is completed, bring slowly to boiling in order to expel the dissolved carbon dioxide and then cool. Transfer the solution, rinsing the beaker with water, into a 1 000 ml volumetric flask, make up to the mark with water and mix thoroughly.

4.2.92 Alkali stock solution (alternative method)

Dissolve $(0,2542 \pm 0,0005)$ g of sodium chloride (4.2.38) and $(0,190\ 7 \pm 0,000\ 5)$ g of potassium chloride (4.2.39) in water in a 1 000 ml volumetric flask and make up to the mark. (See Note to 4.2.95.)

4.2.93 Caesium chloride (CsCl)

4.2.94 Aluminium nitrate ($\text{Al}(\text{NO}_3)_3 \cdot 9\text{H}_2\text{O}$)

4.2.95 Buffer solution

Dissolve 50 g of caesium chloride (4.2.93) and 250 g of aluminium nitrate (4.2.94) in water and make up to 1 000 ml. (See Note).

NOTE These solutions can be obtained made up ready for use.

4.3 Apparatus

4.3.1 **Balance(s)**, capable of weighing to an accuracy of $\pm 0,000\ 5$ g.

4.3.2 Crucibles

4.3.2.1 **Porcelain and/or platinum crucibles**, 20 ml to 25 ml capacity.

The methods specify where platinum crucibles are to be used. Unless platinum is specified, porcelain crucibles may be used.

4.3.2.2 **Lids, suitable lids to be fitted to crucibles (4.3.2.1) where required**

4.3.3 Fire proof ceramic support(s)

For preventing overheating of the crucible, it shall be in thermal equilibrium with the furnace at the moment the crucible is introduced.

4.3.4 Porcelain evaporating dish, of approximately 200 ml.

4.3.5 Electric furnaces(s), naturally ventilated and capable of being set at the following temperatures: $(500 \pm 10)^\circ\text{C}$, $(950 \pm 25)^\circ\text{C}$ and $(1\ 175 \pm 25)^\circ\text{C}$.

4.3.6 Laboratory oven(s), capable of being set at the following temperatures: $(110 \pm 5)^\circ\text{C}$, $(120 \pm 5)^\circ\text{C}$, $(150 \pm 5)^\circ\text{C}$, $(200 \pm 10)^\circ\text{C}$, and $(250 \pm 10)^\circ\text{C}$.

4.3.7 Desiccator(s), containing anhydrous magnesium perchlorate ($\text{Mg}(\text{ClO}_4)_2$) or silica gel.

Where self-indicating silica gel is used, a non-toxic indicator is recommended.

4.3.8 Bulb condenser

4.3.9 Apparatus for determining sulfide

A typical apparatus is shown in Figure 1. A Woolf bottle may be added to control the flow of gas.

The connecting tubes shall be made of a material free from sulfur (polyvinyl chloride, polyethylene, etc.).

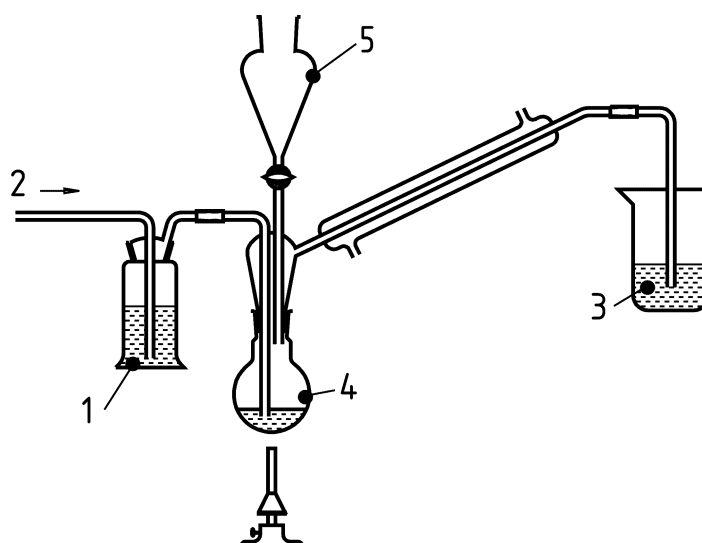

Key

- 1 lead acetate solution (4.2.49)
- 2 air, nitrogen or argon
- 3 ammoniacal solution of zinc sulfate (4.2.48)
- 4 reaction flask

Figure 1 — Typical apparatus for the determination of sulphide

4.3.10 Photometer(s), for measuring the absorbance of a solution in the vicinity of 525 nm and 815 nm.

4.3.11 Cells, for the photometer

4.3.12 Apparatus for measuring the absorbance, at 520 nm and 620 nm of a solution contained in a titration beaker, while stirring.

4.3.13 Stirrer, e.g. magnetic stirrer, with inert, e.g. PTFE, covered bar.

4.3.14 Evaporation apparatus, controlled at $(105 \pm 5)^\circ\text{C}$, e.g. water bath or hot plate.

4.3.15 Sand bath or hot plate, controlled at approximately 400 °C.

4.3.16 Ashless filter papers

NOTE Filter papers with a mean pore diameter of around 2 µm are termed fine, those with a mean pore diameter of around 7 µm are termed medium and those with a mean pore diameter of around 20 µm are termed coarse.

4.3.17 Volumetric glassware

The volumetric glassware shall be of analytical accuracy, i.e. class A as defined in ISO 385 and ISO 835.

4.3.18 pH measuring equipment

4.3.18.1 pH meter, capable of measuring to an accuracy of $\pm 0,05$.

4.3.18.2 pH indicator paper(s), capable of measuring pH in the 0 – 14 range.

4.3.19 Apparatus for the determination of the carbon dioxide (reference method)

Figure 2 shows a typical apparatus which can be fitted with either a cylindrical pressure container, a small electrical compressor or a suitable suction pump which will ensure an even flow of gas or air. The gas (air or nitrogen) entering the apparatus has previously had its carbon dioxide removed by first being passed through an absorbent tube or tower containing the carbon dioxide absorbent (4.2.87). The apparatus consists of a 100 ml distillation flask (14) fitted with a three neck adaptor. Neck (5) is connected to a dropping funnel (4), neck (6) to a connecting tube and neck (8) to a water cooled condenser. The funnel onto (5) and the connecting tube onto (6) are joined together by means of a Y-piece (1), so that the carbon dioxide-free air can flow either through the connecting tube or the funnel by means of a Mohr clip (2).

After the condenser (9), the gas is passed through concentrated sulfuric acid (4.2.16) (10), then through absorption tubes containing the absorbent for hydrogen sulfide (4.2.85) (11) and for water (4.2.86) (12) and subsequently through two absorption tubes (13) which can be weighed and which are three-quarters filled with the absorbent for carbon dioxide (4.2.87) and a quarter with the absorbent for water (4.2.86). The absorbent for carbon dioxide (4.2.87) is placed upstream of the absorbent for water (4.2.86) with respect to the gas flow. Absorption tubes (13) are followed by an additional absorption tube (15), which also contains the absorbent for carbon dioxide and water, which is fitted in order to protect second absorption tube (13) against penetration by carbon dioxide and water from the air.

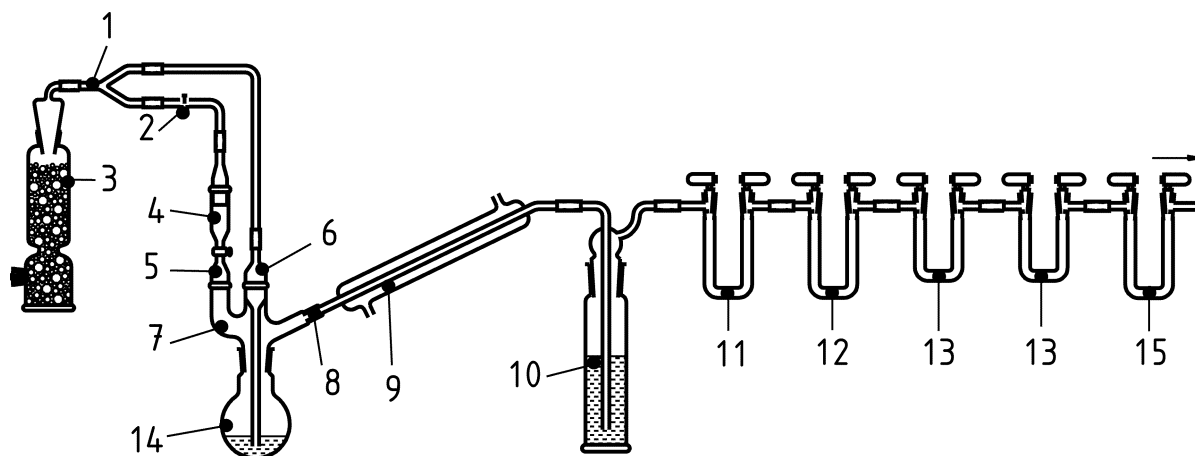

Key

1	Y-piece	9	condenser
2	mohr clip	10	wash bottle with concentrated sulfuric acid (4.2.16)
3	absorption tower containing carbon dioxide absorbent (4.2.87)	11	absorption tube with absorbent for hydrogen sulfide (4.2.85)
4	dropping funnel	12	absorption tube with absorbent for water (4.2.86)
5	dropping funnel connector	13	absorption tubes with absorbents for carbon dioxide (4.2.87) and water (4.2.86)
6	connecting tube connector	14	100 ml distillation flask
7	three-armed still head	15	absorption tubes with absorbents for carbon dioxide (4.2.87) and water (4.2.86)
8	condenser connector		

Figure 2 — Typical apparatus for the determination of carbon dioxide (reference method)

The absorption tubes (13) which are to be weighed may have, for example, the following approximate sizes.

External distance between branches	45 mm
Internal diameter	20 mm
Distance between the lower part of the tube and the upper part of the ground section	75 mm
Tube wall thickness	1,5 mm

4.3.20 Apparatus for the determination of the carbon dioxide content (alternative method)

A typical apparatus is shown in Figure 3. A small vacuum pump is used to generate reduced pressure in the apparatus.

Paraffin may be used instead of sulfuric acid in the final wash bottle (Figure 3) as this bottle only serves as a bubble counter.

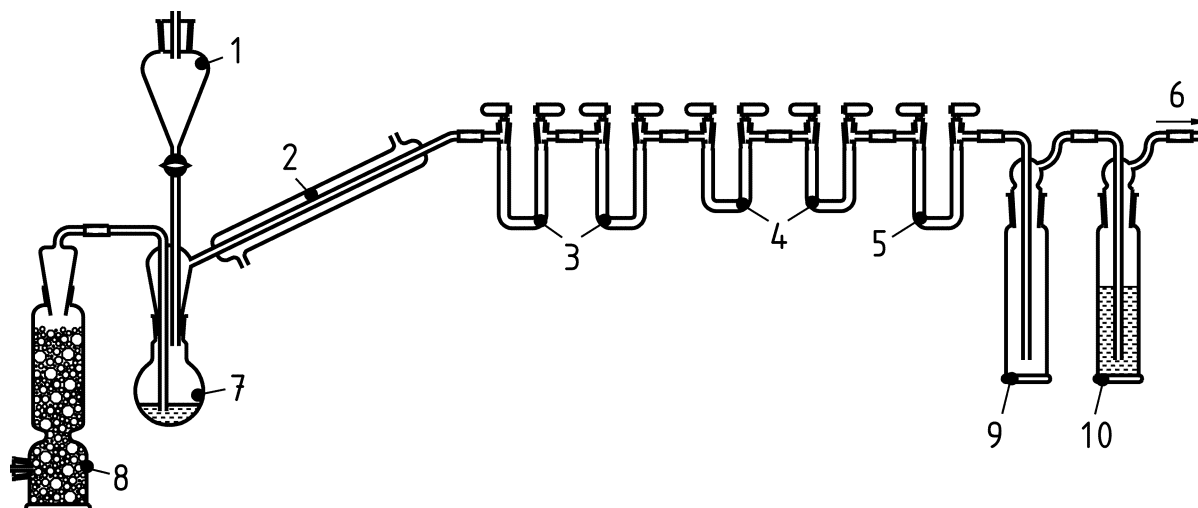

Key

1	dropping funnel for sulfuric acid (4.2.18)	6	to the vacuum pump
2	condenser	7	100 ml distillation flask
3	absorption tubes containing absorbent for water (4.2.86)	8	absorption tower containing absorbent for carbon dioxide (4.2.87)
4	absorption tubes containing absorbent for carbon dioxide (4.2.87) and water (4.2.86)	9	washing bottle (empty)
5	absorption tubes with absorbents for carbon dioxide (4.2.87) and water (4.2.86)	10	washing bottle containing concentrated sulfuric acid (4.2.16) or paraffin

Figure 3 — Typical apparatus for the determination of carbon dioxide (alternative method)

4.3.21 Flame photometer

Of sufficient stability and capable of measuring the intensities of the sodium line at 589 nm and the potassium line at 768 nm. In order to avoid any interference of the determination by alkaline earths, the flame photometer shall be operated with a relatively low temperature by using a propane-air or butane-air flame.

4.3.22 Platinum dish

4.3.23 Filter paper, medium filter paper (4.3.16), prewashed with hot water.

4.3.24 Stirrer, resistant to hydrofluoric acid, e.g. platinum.

4.3.25 Heating lamp, capable of evaporating to dryness samples in aqueous solution.

4.4 Analysis procedure

4.4.1 Determination of loss on ignition

4.4.1.1 Principle

The loss on ignition is determined in an oxidising atmosphere. By igniting the sample in air at $(950 \pm 25) ^\circ\text{C}$ the carbon dioxide and water are driven off and any oxidisable elements present are oxidised to some extent. A correction for the influence of this oxidation on the loss on ignition is described. The error resulting from the oxidation of metallic iron, bivalent iron, or bivalent manganese is usually considered to be negligible and only the correction for the extent of oxidation of any sulfides is applied (see 4.4.1.4).

4.4.1.2 Procedure

Weigh, to $\pm 0,0005$ g, ($1,00 \pm 0,05$) g of cement (m_7) into a crucible which has been previously ignited and tared. Place the covered crucible in the electric furnace (4.3.5) controlled at (950 ± 25) °C. After heating for 5 min, remove the lid and leave the crucible in the furnace for a further 10 min. Allow the crucible to cool to room temperature in the desiccator. Determine constant mass (m_8) in accordance with 4.1.2.

NOTE For cements containing sulfides, a more accurate determination of the loss on ignition can be obtained by determining the sulfate contents before and after ignition. The correction applicable to these cements is given in 4.4.1.4.

4.4.1.3 Calculation and expression of results

Calculate the observed loss on ignition L in percent from the formula:

$$L = \frac{m_7 - m_8}{m_7} \times 100 \quad (9)$$

where

m_7 is the mass of the test portion, in grams;

m_8 is the mass of the ignited test portion, in grams.

4.4.1.4 Correction for oxidation of sulfides

Calculate the correction for the extent of oxidation of sulfide that occurs during the determination of loss on ignition by determining the sulfate present before ignition, SO_3 (initial), and after ignition, SO_3 (final), from the following relationships:

- SO_3 (final) - SO_3 (initial) = SO_3 resulting from the oxidation of sulfides;
- Oxygen taken up = $0,8 \times (\text{SO}_3 \text{ from oxidation of sulfide})$ = correction;
- Corrected loss on ignition = observed loss on ignition (L) + oxygen taken up;

where in a), b) and c) all values are expressed in percent based on the initial mass(es) of unignited test portion(s).

Any corrections applied shall be indicated in the test report.

4.4.1.5 Repeatability and reproducibility

The standard deviation for repeatability is 0,04 %.

The standard deviation for reproducibility is 0,08 %.

4.4.2 Determination of sulfate

4.4.2.1 Principle

Sulfate ions, produced by the decomposition of cement with hydrochloric acid, are precipitated at a pH between 1,0 and 1,5 by a solution of barium chloride. The precipitation of barium sulfate is carried out at boiling point.

The determination is then completed gravimetrically and sulfate expressed as SO_3 .

4.4.2.2 Procedure

Weigh, to $\pm 0,0005$ g, ($1,00 \pm 0,05$) g of cement (m_9), place in a 250 ml beaker, and add 90 ml of water. While stirring the mixture vigorously, add 10 ml of concentrated hydrochloric acid (4.2.2). Heat the solution gently and crush the sample with the flattened end of a glass stirring rod until decomposition is complete. Allow the solution to digest for 15 min at a temperature just below boiling.

Filter the residue on a medium filter paper (4.3.16) into a 400 ml beaker. Wash thoroughly with hot water until free from chloride ions, tested by the silver nitrate test (4.1.3).

Adjust the volume to about 250 ml; if necessary, adjust the pH of the solution to between 1,0 and 1,5 with hydrochloric acid 1 + 11 (4.2.7) or ammonium hydroxide 1 + 16 (4.2.29).

Bring to the boil and boil for 5 min. Check that the solution is clear; if not, start the determination again using a new test portion. While stirring vigorously, maintain the solution at boiling point and add drop by drop 10 ml of the barium chloride solution (4.2.42) heated to just below boiling. Maintain the solution at just below boiling point for at least 30 min, ensuring that the volume is kept between 225 ml and 250 ml, and then allow the covered beaker to stand at room temperature for 12 h to 24 h before filtration.

Filter the precipitate on a fine filter paper (4.3.16) and wash with boiling water until free from chloride ions, tested by the silver nitrate test (4.1.3).

Ignite (4.1.1) at (950 ± 25) °C to constant mass (4.1.2) (m_{10}).

NOTE In general, an ignition period of 15 min is sufficient to achieve constant mass.

4.4.2.3 Calculation and expression of results

Calculate the sulfate content, expressed as SO_3 , in percent from the formula:

$$SO_3 = \frac{m_{10} \times 0,343 \times 100}{m_9} = 34,3 \times \frac{m_{10}}{m_9} \quad (10)$$

where

m_9 is the mass of the test portion, in grams;

m_{10} is the mass of barium sulfate, in grams.

4.4.2.4 Repeatability and reproducibility

The standard deviation for repeatability is 0,07 %.

The standard deviation for reproducibility is 0,08 %.

4.4.3 Determination of residue insoluble in hydrochloric acid and sodium carbonate

4.4.3.1 Principle

This is a method in which the insoluble residue in cement is obtained by treatment with dilute hydrochloric acid in order to minimise the precipitation of soluble silica. The residue from this treatment is treated with a boiling solution of sodium carbonate in order to re-dissolve traces of silica which may have been precipitated. After ignition the residue is determined gravimetrically.

4.4.3.2 Procedure

Weigh, to $\pm 0,0005$ g, ($1,00 \pm 0,05$) g of cement (m_{11}), place in a 250 ml beaker, add 90 ml of water and, while stirring the mixture vigorously, add 10 ml of concentrated hydrochloric acid (4.2.2).

Heat the solution gently and crush the sample with the flattened end of a glass stirring rod until decomposition is complete. Allow the solution to digest for 15 min at a temperature just below boiling.

Filter the residue on a medium filter paper (4.3.16) and wash thoroughly with almost boiling water. Transfer the filter paper and its contents back to the reaction beaker and add 100 ml of the sodium carbonate solution (4.2.46). Boil for approximately 30 min. Filter on a medium filter paper and wash with almost boiling water, then four times with hot hydrochloric acid 1 + 19 (4.2.8) until pH < 2 by indicator paper (4.3.18.2) is obtained and with almost boiling water until free from chloride ions, tested by the silver nitrate test (4.1.3).

Ignite (4.1.1) at (950 ± 25) °C to constant mass (4.1.2) (m_{12}).

NOTE In general, an ignition period of 30 min is sufficient to achieve constant mass.

If a cloudy filtrate is observed, filter again on a fine filter paper, wash thoroughly with hot water and combine the two residues on their filter papers to ignite them. If in spite of this operation the filtrate remains cloudy, its effect on the insoluble residue may be neglected.

4.4.3.3 Calculation and expression of results

Calculate the insoluble residue in percent from the formula:

$$\text{Insoluble residue} = \frac{m_{12}}{m_{11}} \times 100 \quad (11)$$

where

m_{11} is the mass of the test portion, in grams;

m_{12} is the mass of the ignited insoluble residue, in grams.

4.4.3.4 Repeatability and reproducibility

The standard deviation for repeatability is 0,04 %.

The standard deviation for reproducibility is 0,06 %.

4.4.4 Determination of residue insoluble in hydrochloric acid and potassium hydroxide

4.4.4.1 Principle

This is a method in which the insoluble residue in cement is obtained initially by treatment with a hydrochloric acid solution. The residue from this treatment is then treated with a boiling solution of potassium hydroxide. After ignition, the residue is determined gravimetrically.

4.4.4.2 Procedure

Weigh, to $\pm 0,0005$ g, ($1,00 \pm 0,05$) g of cement (m_{13}), place in a porcelain dish (4.3.4), add 25 ml of water and disperse using a glass stirring rod. Add 40 ml of concentrated hydrochloric acid (4.2.2). Heat the solution gently and crush the sample with the flattened end of a glass stirring rod until decomposition is complete. Evaporate to dryness on a water bath (4.3.14). Repeat the operation twice more with 20 ml concentrated hydrochloric acid (4.2.2).

Treat the residue from the third evaporation with 100 ml of hydrochloric acid 1 + 3 (4.2.5). Re-heat, filter on a medium filter paper (4.3.16) and wash with almost boiling water until free from chloride ions, tested by the silver nitrate test (4.1.3).

Transfer the filter paper and its contents to a 250 ml conical flask fitted with a bulb condenser (4.3.8) and add 100 ml of the potassium hydroxide solution (4.2.47). Leave to stand for 16 h at room temperature and then boil the solution under reflux for 4 h.

Filter on a medium filter paper (4.3.16) and wash with water then with 100 ml of hydrochloric acid 1 + 9 (4.2.6) and finally with almost boiling water until free from chloride ions, tested by the silver nitrate test (4.1.3).

Ignite (4.1.1) at (950 ± 25) °C to constant mass (4.1.2) (m_{14}).

NOTE In general, an ignition period of 30 min is sufficient to achieve constant mass.

4.4.4.3 Calculation and expression of results

Calculate the insoluble residue in percent from the formula:

$$\text{Insoluble residue} = \frac{m_{14}}{m_{13}} \times 100 \quad (12)$$

where

m_{13} is the mass of the test portion, in grams;

m_{14} is the mass of the ignited insoluble residue, in grams.

4.4.4.4 Repeatability and reproducibility

The standard deviation for repeatability is 0,15 %.

The standard deviation for reproducibility is 0,18 %.

4.4.5 Determination of sulfide

4.4.5.1 Principle

The cement is decomposed by hydrochloric acid under reducing conditions. The sulfides are transformed into hydrogen sulfide, which is carried over by a gaseous stream into an ammoniacal solution of zinc sulfate. The amount of precipitated zinc sulfide is determined by iodometry.

4.4.5.2 Procedure

Use the apparatus described in 4.3.9. Weigh, to $\pm 0,0005$ g, $(1,00 \pm 0,05)$ g of cement (m_{15}) (see Note 1), place in a 250 ml stoppered round bottom flask with a ground glass joint. Add about 2,5 g of tin (II) chloride (4.2.34) and 0,1 g of chromium (4.2.25) (see Note 2). Disperse in 50 ml of water. Fix the flask to the ground neck of the dropping funnel and connect to the condenser the glass outlet tube which dips into the beaker containing 15 ml of ammoniacal zinc sulfate solution (4.2.48) and 285 ml of water. Connect the gas supply (air, nitrogen or argon) and adjust the flow to about 10 ml per min. Stop the flow of gas. Release 50 ml of hydrochloric acid 1 + 1 (4.2.3) from the dropping funnel ensuring that a small quantity of acid remains in the dropping funnel to provide a seal. Reconnect the gas supply, heat the contents of the flask to boiling and boil for 10 min. Disconnect the outlet tube which can serve as a stirrer during the titration.

Cool to room temperature, add 10 ml of potassium iodate solution approximately 0,0166 mol/l (4.2.61) by pipette and 25 ml of concentrated hydrochloric acid (4.2.2). Titrate with sodium thiosulfate solution (4.2.62)

until pale yellow. Then add 2 ml of starch solution (4.2.50) and titrate until the colour changes from blue to colourless.

NOTE 1 If the sulfide content is low (<0,10 %), the mass of the test portion will preferably be increased in proportion.

NOTE 2 Chromium assists in the decomposition of any pyrites (FeS₂) present in the cement.

4.4.5.3 Calculation and expression of results

Calculate the sulfide content in percent from the formula:

$$S^{2-} = \frac{[(V_8 \times F) - (V_9 \times f)] \times 1,603 \times 100}{1000 \times m_{15}} = 0,1603 \times \frac{[(V_8 \times F) - (V_9 \times f)]}{m_{15}} \quad (13)$$

where

V_8 is the volume of potassium iodate solution, in millilitres;

F is the factor of the potassium iodate solution;

V_9 is the volume of the sodium thiosulfate solution used for the titration, in millilitres;

f is the factor of the sodium thiosulfate solution;

m_{15} is the mass of the test portion, in grams.

4.4.5.4 Repeatability and reproducibility

The standard deviation for repeatability is 0,02 %.

The standard deviation for reproducibility is 0,04 %.

4.4.6 Determination of manganese

4.4.6.1 Principle

The manganese present is oxidised to permanganate (MnO₄⁻) by means of potassium periodate. The absorbance of the violet solution is measured at 525 nm. The ferric (Fe³⁺) ions are complexed with phosphoric acid which also assists the formation of MnO₄⁻ and stabilises the colour of the solution.

4.4.6.2 Procedure

Weigh, to ± 0,000 5 g, (0,1 to 1,0) g of cement (m_{16}) into a 250 ml beaker. Disperse in about 75 ml of water. Stir, add cautiously 15 ml of nitric acid (4.2.13) and boil in a fume cupboard until free from any hydrogen sulfide (H₂S) present and all the cement (see Note) is decomposed.

For contents of manganese of the order of 0,01 %, taking a test portion close to 1 g and varying its amount to suit the probable manganese concentration is recommended.

NOTE 2 For cements with a high insoluble residue, fusion of a separate test portion can be necessary to obtain complete solution. This is carried out by the method of sintering with sodium peroxide as described for the determination of the main constituents (see 4.5.2).

Filter through a medium filter paper (4.3.16) into a 400 ml beaker. Wash the residue with hot water until the volume of the filtrate is 120 ml. To this filtrate, add 10 ml of phosphoric acid (4.2.20), mix and add 1,5 g of potassium periodate (4.2.36). Heat to boiling until the characteristic pink colour of permanganate appears. If it does not appear, reduce the acidity by adding a few drops of concentrated ammonium hydroxide (4.2.26).

Once the colour has appeared, continue boiling gently for 30 min. Cool and transfer the contents of the beaker to a 200 ml volumetric flask. Cool to room temperature and make up to the mark with water.

Using a photometer (4.3.10 and 4.3.11), measure the absorbance of the solution against water at a wavelength of approximately 525 nm.

Record the absorbance value to three decimal places. The absorbance read from the calibration curve (4.2.63.3) corresponding to the cell used gives the concentration of manganese, C , in milligrams of manganese per 200 ml. Record the manganese concentration, C , to three decimal places.

4.4.6.3 Calculation of results

Calculate the manganese content Mn in percent from the formula:

$$\text{Mn} = \frac{C \times 100}{1000 \times m_{16}} = 0,1 \times \frac{C}{m_{16}} \quad (14)$$

where

C is the manganese (Mn) concentration of the solution, in milligrams per 200 ml;

m_{16} is the mass of the test portion, in grams.

4.4.6.4 Repeatability and reproducibility

The standard deviation for repeatability is 0,003 %.

The standard deviation for reproducibility is 0,03 %.

4.4.6.5 Expression of results

The manganese content is normally expressed as MnO or Mn₂O₃. The following formulae are used in their calculation:

$$\text{MnO} = 1,29 \times \text{Mn} \text{ ; in percent; } \quad (15)$$

$$\text{Mn}_2\text{O}_3 = 1,44 \times \text{Mn} \text{ ; in percent. } \quad (16)$$

4.5 Determination of major elements

4.5.1 Principle

The analysis is carried out after the cement is completely dissolved. The decomposition with hydrochloric acid and ammonium chloride (alternative method) may be used for cement with an insoluble residue (as determined in accordance with 4.4.3) not exceeding 1,5 %.

The cement is decomposed by sintering with sodium peroxide or by treatment with hydrochloric acid in the presence of ammonium chloride. In the first case, after dissolution of the sintered solid in hydrochloric acid, the major part of the silica is precipitated either by double evaporation or by hydrochloric acid with coagulation by polyethylene oxide; in the second case, the major part of the silica is separated by the treatment. The impure silica precipitated is treated with hydrofluoric acid and sulfuric acid to volatilise silica; the residue, treated with a mixture of sodium carbonate and sodium chloride, is dissolved in hydrochloric acid and added to the silica filtrate.

In the case of the treatment with hydrochloric acid in the presence of ammonium chloride, if the residue obtained after volatilisation of impure silica by means of hydrofluoric acid and sulfuric acid is greater than

0,5 %, the method is not applicable. In this case it is necessary to decompose the cement by sodium peroxide.

In the final solution, the soluble (residual) silica is determined by photometric determination, and iron (III) oxide, aluminium oxide, calcium oxide and magnesium oxide are determined by complexometric methods.

The schematic diagram of the chemical analysis is shown in Figure 4.

The relative amounts of impure, pure and soluble (residual) silica may vary depending on the procedure used, but the same result for the total silica is obtained whichever path in Figure 4 is chosen.

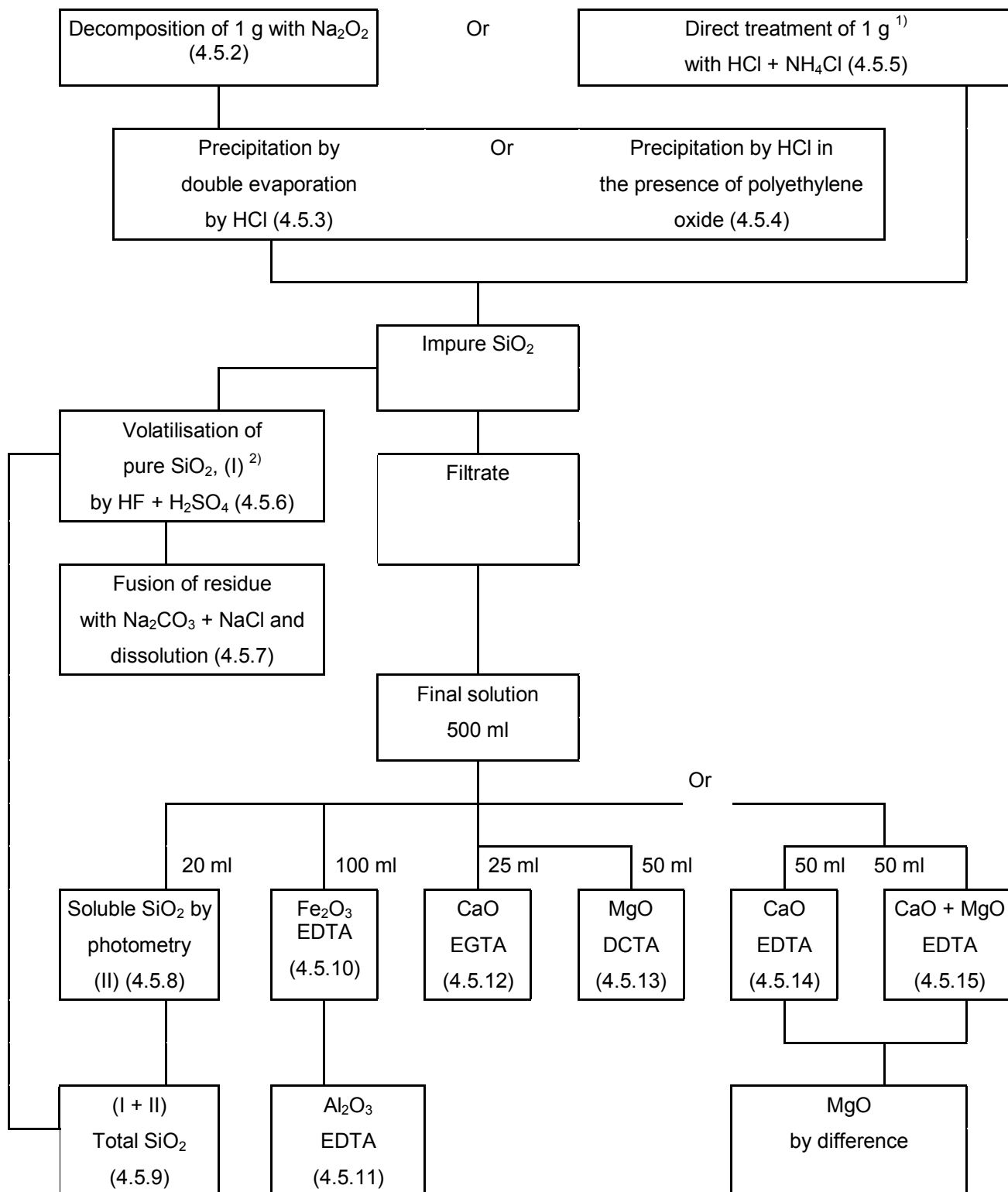

Figure 4 — Schematic diagram for analysis of the major elements

If the residue insoluble in hydrochloric acid and sodium carbonate (see 4.4.3) is greater than 1,5 %, it is necessary to use the method of decomposition by sodium peroxide.

When the ammonium chloride method is used, if the residue after volatilisation with hydrofluoric acid and sulfuric acid exceeds 0,5 %, it is necessary to recommence the analysis using the decomposition by sodium peroxide.

4.5.2 Decomposition with sodium peroxide

Weigh, to $\pm 0,0005$ g, ($1,00 \pm 0,05$) g of cement (m_{17}) and place, with about 2 g of sodium peroxide (4.2.37), into a platinum crucible (4.3.2.1); mix thoroughly with a spatula. Brush back into the mixture any particles adhering to the spatula. Cover the mixture with about 1 g of sodium peroxide. Carefully preheat the crucible fitted with a lid (4.3.2.2) for about 2 min at the opening of the furnace (4.3.5) before placing it on its support (4.3.3) in the heated zone controlled at a uniform temperature of (500 ± 10) °C.

After 30 min, remove the crucible from the furnace and allow it to cool to room temperature. The sintered solid mass should not stick to the sides of the crucible. If it does, then repeat the decomposition at a temperature 10 °C lower than was first used.

Transfer the sintered solid mass to a 400 ml beaker and rinse the crucible with 150 ml of cold water.

Cover the beaker with a watch glass and heat until the solid is completely dispersed. Then add cautiously 50 ml of concentrated hydrochloric acid (4.2.2). The solution obtained shall be perfectly clear. If not, reject it and repeat the decomposition by peroxide at a temperature increased by 10 °C or for double the time in the furnace. Add to the solution 1 ml of sulfuric acid 1 + 1 (4.2.17). Bring the solution to the boil and boil for 30 min.

This solution is ready for use for the precipitation of silica in accordance with 4.5.3 or 4.5.4.

4.5.3 Precipitation and determination of silica — Double evaporation method (reference method)

4.5.3.1 Procedure

Evaporate to dryness the solution prepared as described in 4.5.2 on evaporation apparatus controlled at (105 ± 5) °C (4.3.14). Moisten with several drops of concentrated hydrochloric acid (4.2.2). Leave for 1 h at this temperature.

After cooling to room temperature, treat the residue with 10 ml of concentrated hydrochloric acid (4.2.2). After a few minutes, dilute with 50 ml of water, bring to the boil and filter the hot solution through a medium filter paper (4.3.16) into a 500 ml volumetric flask. Wash the filter and the residue three times with hot water. Evaporate the filtrate and washings in the same way, treat with 10 ml of concentrated hydrochloric acid (4.2.2) and dilute with 50 ml of water. Boil, then pass through the same filter into a 500 ml volumetric flask. Where filtration is difficult a second filter paper may be used in which case the following procedure shall be applied to both filter papers and precipitated residue.

Wash the filter and precipitate with hot water until free from chloride ions, tested by the silver nitrate test (4.1.3). Collect the washings in the same 500 ml volumetric flask.

Ignite (4.1.1) the filter and precipitate, to constant mass (4.1.2) (m_{18}), in a platinum crucible at $(1\ 175 \pm 25)$ °C.

NOTE In general, an ignition period of 60 min is sufficient to obtain constant mass.

Volatilise the ignited precipitate as described in 4.5.6. Add the decomposed evaporation residue solution (4.5.7) to the filtrate and washings in the 500 ml volumetric flask. The combined solutions are used for the colorimetric determination of soluble silica (i.e. the residual silica in solution) (4.5.8) and for the complexometric determinations of iron (III) oxide (4.5.10), aluminium oxide (4.5.11), calcium oxide (4.5.12 or 4.5.14) and magnesium oxide (4.5.13 or 4.5.15).

4.5.3.2 Calculation and expression of results

Calculate the impure silica content in percent from the formula:

$$\text{Impure SiO}_2 = \frac{m_{18}}{m_{17}} \times 100 \quad (17)$$

where

m_{17} is the mass of the test portion as in 4.5.2, in grams;

m_{18} is the mass determined in accordance with 4.5.3.1, in grams.

4.5.4 Precipitation and determination of silica — Polyethylene oxide method (alternative method)

4.5.4.1 Procedure

Evaporate to dryness the solution prepared as described in 4.5.2. Allow the beaker to cool. Treat the residue with 5 ml of water and 10 ml of concentrated hydrochloric acid (4.2.2). While stirring, add some ashless filter paper pulp to the mixture and then 5 ml of the polyethylene oxide solution (4.2.51) ensuring that the precipitate and the polyethylene oxide are thoroughly mixed, especially the precipitate adhering to the sides of the beaker. Stir the mixture thoroughly then add 10 ml of water, stirring briefly and leave to stand for 5 min.

Filter through a medium filter paper (4.3.16) into a 500 ml volumetric flask and rinse with hot hydrochloric acid 1 + 19 (4.2.8). Remove any precipitate adhering to the sides of the beaker using a rubber or plastics scraper. Wash the filter and precipitate at least five times with hot hydrochloric acid 1 + 19, then rinse with hot water, ensuring that the residue in the filter is broken up thoroughly during washing, until free from chloride ions, tested by the silver nitrate test (4.1.3).

Collect the washings in the same 500 ml volumetric flask.

Ignite (4.1.1) the filter and the precipitate, to constant mass (4.1.2) (m_{19}), in a platinum crucible at $(1\ 175 \pm 25)$ °C.

NOTE In general, an ignition period of 60 min is sufficient to obtain constant mass.

Volatilise the ignited precipitate as described in 4.5.6. Add the decomposed evaporation residue (4.5.7) to the filtrate and washings in the 500 ml volumetric flask. The combined solution is used for the colorimetric determination of soluble silica (i.e. the residual silica in solution) (4.5.8) and for the complexometric determinations of iron (III) oxide (4.5.10), aluminium oxide (4.5.11), calcium oxide (4.5.12 or 4.5.14) and magnesium oxide (4.5.13 or 4.5.15).

4.5.4.2 Calculation and expression of results

Calculate the impure silica content in percent from the formula:

$$\text{Impure SiO}_2 = \frac{m_{19}}{m_{17}} \times 100 \quad (18)$$

where

m_{17} is the mass of the test portion used in 4.5.2, in grams;

m_{19} is the mass determined in accordance with 4.5.4.1, in grams.

4.5.5 Decomposition with hydrochloric acid and ammonium chloride and precipitation of silica (alternative method)

4.5.5.1 General

This method is to be used only where the insoluble residue, as determined in 4.4.3, does not exceed 1,5 %.

4.5.5.2 Procedure

Weigh, to $\pm 0,0005$ g, ($1,00 \pm 0,05$) g of cement (m_{20}) and place in a 100 ml beaker. Add about 1 g of ammonium chloride (4.2.33) and mix thoroughly with a glass stirring rod. Cover the beaker with a watch glass and cautiously add 10 ml of concentrated hydrochloric acid (4.2.2) taking care to let the acid run down the side of the beaker. When effervescence has stopped, add 10 drops of nitric acid (4.2.13) and stir with a glass stirring rod crushing any lumps.

Place the beaker and its watch glass on a boiling water bath and leave for 30 min. Dilute the contents of the beaker with a small quantity of hot water and filter through a coarse filter paper (4.3.16) into a 500 ml volumetric flask. Transfer the gelatinous precipitate to the filter as completely as possible without dilution, and allow the solution to drain through the filter. Remove all precipitate adhering to the beaker by using a rubber or plastics scraper.

Rinse the beaker and precipitate with hot hydrochloric acid 1 + 99 (4.2.9). Then wash the precipitate and filter with small amounts of hot water until free from chloride ions, tested by the silver nitrate test (4.1.3).

Collect the washings in the same 500 ml volumetric flask.

This is used, together with the evaporation residue decomposed as described in 4.5.7, for the photometric determination of soluble silica (i.e. residual silica in solution) in accordance with 4.5.8.

Ignite (4.1.1) the filter and the precipitate, to constant mass (4.1.2) (m_{21}), in a platinum crucible at ($1\ 175 \pm 25$) °C.

NOTE In general, an ignition period of 60 min is sufficient to obtain constant mass.

Volatilise the ignited precipitate as described in 4.5.6.

4.5.5.3 Calculation and expression of results

Calculate the impure silica in percent from the formula:

$$\text{Impure SiO}_2 = \frac{m_{21}}{m_{20}} \times 100 \quad (19)$$

where

m_{20} is the mass of the test portion used in 4.5.5.2, in grams;

m_{21} is the mass determined in accordance with 4.5.5.2, in grams.

4.5.6 Determination of pure silica

4.5.6.1 Procedure

Moisten the precipitate, obtained in accordance with 4.5.3.1 (m_{18}) or 4.5.4.1 (m_{19}) or 4.5.5.2 (m_{21}), with about 0,5 ml to 1 ml of water, add approximately 10 ml of hydrofluoric acid (4.2.11) then two drops of sulfuric acid (4.2.16). Evaporate in a fume cupboard over a sand bath or hot plate (4.3.15), then continue to heat until free from white sulfuric acid fumes.

Ignite the crucible with the evaporation residue in an electric furnace (4.3.5) at ($1\ 175 \pm 25$) °C for 10 min, leave to cool to room temperature in a desiccator and weigh (m_{22}).

Decompose the evaporation residue as described in 4.5.7. If the residue obtained by this method exceeds 0,5 %, restart the analysis using the method of decomposition with sodium peroxide (4.5.2).

4.5.6.2 Calculation and expression of results

Calculate the pure silica content in percent from the formula:

$$\text{Pure SiO}_2 = \frac{m_{24} - m_{22}}{m_{23}} \times 100 \quad (20)$$

where

m_{22} is the mass determined in accordance with 4.5.6.1, in grams;

m_{23} is the mass of the test portion used in 4.5.2 (m_{17}) or in 4.5.5.2 (m_{20}), in grams;

m_{24} is the mass determined in accordance with 4.5.3.1 (m_{18}), 4.5.4.1 (m_{19}) or 4.5.5.2 (m_{21}), in grams.

4.5.7 Decomposition of the evaporation residue

To the evaporation residue, obtained in accordance with 4.5.6.1, add about 2 g of the sodium carbonate and sodium chloride mixture (4.2.41) and fuse to a bright red heat e.g. using a gas burner. Swirl the melt frequently until the residue is completely dissolved.

Check visually that no part of the residue remains at the base of the crucible. Allow the crucible and its contents to cool, transfer to a 250 ml beaker, add about 100 ml water and acidify with a few millilitres of concentrated hydrochloric acid (4.2.2). When the decomposed mass is completely dissolved, remove the platinum crucible from the solution and rinse it with water.

Check that the solution is clear. If not, filter through a medium filter paper (4.3.16), wash, burn off the paper, ignite and then repeat the decomposition as above. Transfer the solution to the 500 ml volumetric flask containing the filtrate and washings from the precipitation of silica in accordance with 4.5.3.1 or 4.5.4.1 or 4.5.5.2; make up to the mark with water.

After shaking the flask vigorously, this solution is ready to be used in the photometric determination of the soluble silica (4.5.8) and also in the complexometric determinations of iron (III) oxide (4.5.10), aluminium oxide (4.5.11), calcium oxide (4.5.12 or 4.5.14) and magnesium oxide (4.5.13 or 4.5.15).

4.5.8 Determination of soluble silica

4.5.8.1 Procedure

Pipette 20 ml of the solution prepared in accordance with 4.5.7 from the 500 ml volumetric flask into a polyethylene beaker already containing a magnetic stirrer bar (4.3.13) and add 20 ml water. While stirring with the magnetic stirrer (4.3.13), add 15 drops of to (1,60 ± 0,05) by adding, drop by drop, sodium hydroxide (4.2.31) or hydrochloric acid 1 + 2 (4.2.4), using hydrofluoric acid 1 + 3 (4.2.12). Stir again for at least 1 min. Then pipette 15 ml of the boric acid solution (4.2.52). Add from a pipette 5 ml of the ammonium molybdate solution (4.2.55) to the solution. Adjust the pH of the solution a pH meter (4.3.18.1) calibrated with a buffer solution of similar pH value (e.g. 1,40 see 4.2.60).

Transfer the solution to a 100 ml volumetric flask and rinse the beaker with hydrochloric acid of pH 1,60 (4.2.10). After 20 min, add from a pipette 5 ml of the citric acid solution (4.2.53), stir and leave to stand for 5 min. Then add from a pipette 2 ml of the reducing solution (4.2.59). (Time 0.)

Make up to volume with dilute hydrochloric acid of pH 1,60 (4.2.10) and mix. At time (0 + 30) min measure the absorbance with the photometer (4.3.10) against a blank solution prepared in a similar way and using the same wavelength and a cell (4.3.11) of the same optical length as used for the construction of the calibration curve (4.2.64.5). The silica concentration (m_{25}) in mg SiO₂/100 ml is read from the calibration curve.

4.5.8.2 Calculation and expression of results

Calculate the soluble silica content in percent from the formula:

$$\text{Soluble SiO}_2 = \frac{500 \times m_{25} \times 100}{20 \times 1000 \times m_{23}} = 2,5 \times \frac{m_{25}}{m_{23}} \quad (21)$$

where

m_{23} is the mass of the test portion used in 4.5.2 (m_{17}) or 4.5.5.2 (m_{20}), in grams;

m_{25} is the silica concentration of the solution in accordance with 4.5.8.1, in milligrams of SiO_2 in 100 ml.

4.5.9 Determination of total silica

4.5.9.1 Calculation and expression of results

The total silica content, in percent, is the sum of the pure silica content (4.5.6) and the soluble silica content (4.5.8).

4.5.9.2 Repeatability and reproducibility

The standard deviation for repeatability is 0,10 %.

The standard deviation for reproducibility is 0,25 %.

4.5.10 Determination of iron (III) oxide

4.5.10.1 General

The presence of titanium affects the speed of the titration of iron by EDTA. This cause of error can be overcome by proceeding slowly, for example with the help of an automatic burette. It is equally possible to mask the titanium by adding 2 ml of sulfuric acid 1 + 1 (4.2.17) to the solution before titration.

This method uses photometric determination of the end-point. It is also possible to make visual observation of the titration although with less precision. Sulfosalicylic acid (4.2.73) is a suitable indicator (colour changes from violet to clear yellow).

4.5.10.2 Procedure

Pipette 100 ml of the solution prepared in accordance with 4.5.7 from the 500 ml volumetric flask into a beaker compatible with the measuring apparatus (4.3.12). Then make up with water to a volume suitable for the correct operation of the equipment.

Add 0,5 g amino-acetic acid (4.2.24) and 0,3 g to 0,4 g of sulfosalicylic acid indicator (4.2.73).

Using a pH meter (4.3.18.1), adjust the pH of this solution to $(1,5 \pm 0,1)$ with the ammonium hydroxide 1 + 1 (4.2.27) and 1 + 10 (4.2.28).

Heat to $(47,5 \pm 2,5)$ °C. Place the beaker in the apparatus (4.3.12) set at 520 nm and, while stirring the solution, titrate with the approximately 0,03 mol/l EDTA solution (4.2.66). In the vicinity of the indicator colour change, construct a curve of the readings from the measuring apparatus as a function of the volume of EDTA solution added. Record the total volume V_{tot} of EDTA solution added. The volume at the end point V_{10} is determined from the intersection of the line of greatest slope in the region of the colour change and the line of

almost constant absorbance after the colour change. The excess volume V_{Ex} of EDTA solution added is determined as volume V_{tot} less volume V_{10} .

During the titration, the temperature of the solution shall not exceed 50 °C. Otherwise the determination shall be repeated.

This titrated solution is retained for the determination of aluminium oxide content in accordance with 4.5.11.1.

4.5.10.3 Calculation and expression of results

$$Fe_2O_3 = \frac{0,03 \times 159,692 \times 500 \times V_{10} \times f_D}{2 \times 1000 \times 100 \times m_{23}} \times 100 = 1,1977 \times \frac{V_{10} \times f_D}{m_{23}} \quad (22)$$

where

V_{10} is the volume of the approximately 0,03 mol/l EDTA solution used for the titration, in millilitres;

f_D is the factor of the approximately 0,03 mol/l EDTA solution determined in accordance with 4.2.66;

m_{23} is the mass of the test portion used in 4.5.2 (m_{17}) or 4.5.5.2 (m_{20}), in grams.

4.5.10.4 Repeatability and reproducibility

The standard deviation for repeatability is 0,08 %.

The standard deviation for reproducibility is 0,15 %.

4.5.11 Determination of aluminium oxide

4.5.11.1 Procedure

Cool the solution retained from 4.5.10.2 to room temperature. Then add 5 ml of acetic acid (4.2.23) then, drop by drop, the ammonium acetate solution (4.2.57) so as to obtain a pH of (3,05 ± 0,05). This range shall be strictly observed and controlled by means of the pH meter (4.3.18.1). The pH shall not exceed 3,10. Bring to the boil add three drops of the copper complexonate solution (4.2.67) and 2 ml of PAN indicator (4.2.74).

During the titration, keep the solution gently boiling (work in a fume cupboard). Titrate with the approximately 0,03 mol/l EDTA solution (4.2.66) until the colour changes from violet-pink to pale yellow. When the pink colour reappears, add the EDTA solution drop by drop until the yellow colour persists for at least 1 min.

4.5.11.2 Calculation and expression of results

Calculate the aluminium oxide content in percent from the formula:

$$Al_2O_3 = \frac{0,03 \times 101,961 \times 500 \times V_{11} \times f_D}{2 \times 1000 \times 100 \times m_{23}} \times 100 = 0,7647 \times \frac{V_{11} \times f_D}{m_{23}} \quad (23)$$

where

V_{11} is the volume of the approximately 0,03 mol/l EDTA solution used for the titration plus the excess volume V_{Ex} (see 4.5.10.2), in millilitres;

f_D is the factor of the 0,03 mol/l EDTA solution determined in accordance with 4.2.66.3;

m_{23} is the mass of the test portion used in 4.5.2 (m_{17}) or 4.5.5.2 (m_{20}), in grams.

4.5.11.3 Repeatability and reproducibility

The standard deviation for repeatability is 0,10 %.

The standard deviation for reproducibility is 0,25 %.

4.5.12 Determination of calcium oxide by EGTA (reference method)

4.5.12.1 General

This method uses photometric determination of the end-point. It is possible to make visual observations of the titration, although with less precision. The mixed calcein and methylthymol blue indicator (4.2.76) is suitable (colour change from pale green to pink) for both photometric and visual methods.

NOTE In this method any strontium oxide is determined and expressed as calcium oxide.

4.5.12.2 Procedure

Pipette 25 ml of the solution prepared in accordance with 4.5.7 from the 500 ml volumetric flask into a beaker compatible with the measuring apparatus (4.3.12) and make up to the same volume as in 4.2.68.3 with water and then add 25 ml of the triethanolamine solution 1 + 4 (4.2.58). Using the pH meter (4.3.18.1), adjust the pH of this solution to $(12,5 \pm 0,5)$ with sodium hydroxide solution (4.2.31). Add, without weighing, about 0,1 g of murexide (4.2.70) or calcein indicator (4.2.71). Place the beaker in the apparatus (4.3.12) set at 520 nm when using calcein or at 620 nm when using murexide and, while stirring, titrate with the approximately 0,03 mol/l EGTA solution (4.2.68).

In the vicinity of the colour change, construct a curve of the readings from the measuring apparatus as a function of the volume of EGTA solution added. The volume V_{12} used is determined from the intersection of the line of greatest slope in the region of the colour change and the line of almost constant absorbance after the colour change.

4.5.12.3 Calculation and expression of results

Calculate the calcium oxide content in percent from the formula:

$$\text{CaO} = \frac{0,03 \times 56,08 \times 500 \times V_{12} \times f_G}{1000 \times 25 \times m_{23}} \times 100 = 3,3648 \times \frac{V_{12} \times f_G}{m_{23}} \quad (24)$$

where

- V_{12} is the volume of the approximately 0,03 mol/l EGTA solution used for the titration, in millilitres;
- f_G is the factor of the approximately 0,03 mol/l EGTA solution determined in accordance with 4.2.68.3;
- m_{23} is the mass of the test portion used in 4.5.2 (m_{17}) or 4.5.5.2 (m_{20}), in grams.

4.5.12.4 Repeatability and reproducibility

The standard deviation for repeatability is 0,18 %.

The standard deviation for reproducibility is 0,37 %.

4.5.13 Determination of magnesium oxide by DCTA (reference method)

4.5.13.1 General

This method uses photometric determination of the end-point. It is possible to make visual observations of the titration, although with less precision. Methylthymol blue (4.2.76) is a suitable indicator (colour change from blue to grey).

4.5.13.2 Procedure

Pipette 50 ml of the solution prepared in accordance with 4.5.7 from the 500 ml volumetric flask into a beaker compatible with the measuring apparatus (4.3.12), add 50 ml of triethanolamine solution 1 + 4 (4.2.58) and a volume V_{13} of the EGTA solution (4.2.68). Calculate the volume V_{13} required in millilitres from the formula:

$$V_{13} = (2 \times V_{12}) + 1,5 \quad (25)$$

where

V_{12} is the volume of the EGTA solution used for titration in accordance with 4.5.12.2, in millilitres;

V_{13} is the calculated volume of the EGTA solution, in millilitres.

After addition of the calculated volume of EGTA solution, dilute with water to a volume suitable for the correct operation of the apparatus. Using the pH meter (4.3.18.1), adjust the pH of this solution to $(10,5 \pm 0,5)$ with concentrated ammonium hydroxide (4.2.26).

Add, without weighing, about 0,1 g of methylthymol blue indicator (4.2.75).

Place the beaker in the apparatus (4.3.12) set at 620 nm and, while stirring the solution, titrate with the approximately 0,01 mol/l DCTA solution (4.2.69). In the vicinity of the colour change of the indicator, construct a curve of the absorbance values as a function of the volume of DCTA solution added. The volume V_{14} used is determined from the intersection of the line of greatest slope in the region of the colour change and the line of almost constant absorbance after the colour change.

4.5.13.3 Calculation and expression of results

Calculate the magnesium oxide content in percent from the formula:

$$\text{MgO} = \frac{0,01 \times 40,311 \times 500 \times V_{14} \times f_c}{1000 \times 50 \times m_{23}} \times 100 = 0,4031 \times \frac{V_{14} \times f_c}{m_{23}} \quad (26)$$

where

V_{14} is the volume of the approximately 0,01 mol/l DCTA solution used for the titration, in millilitres;

f_c is the factor of the approximately 0,01 mol/l DCTA solution determined in accordance with 4.2.69.3;

m_{23} is the mass of the test portion used in 4.5.2 (m_{17}) or 4.5.5.2 (m_{20}), in grams.

4.5.13.4 Repeatability and reproducibility

The standard deviation for repeatability is 0,15 %.

The standard deviation for reproducibility is 0,15 %.

4.5.14 Determination of calcium oxide by EDTA (alternative method)

4.5.14.1 General

This method uses photometric determination of the end-point. It is possible to determine the end-point of the titration visually. In this case Calcon (4.2.72) (colour change from pink to blue), mixed calcein and methylthymol blue indicator (4.2.76) (colour change pink to yellow) or Patton and Reeders reagent (4.2.77) (colour change from purple to clear blue) are suitable indicators.

NOTE In this method, any strontium oxide is determined and expressed as calcium oxide.

4.5.14.2 Restriction on the method

This method can be used for determination of calcium oxide in the presence of manganese. Where the method is to be used in conjunction with the method of determination of magnesium oxide by EDTA (see 4.5.15), it shall be preceded by the determination of manganese content (see 4.4.6) for comparison with the limit given in 4.5.15.2 for manganese oxide.

4.5.14.3 Procedure

Pipette 50 ml of the solution prepared in accordance with 4.5.7 from the 500 ml volumetric flask into a beaker compatible with the measuring apparatus (4.3.12). Then dilute with water to a volume suitable for the correct operation of the equipment. Add 50 ml of the triethanolamine solution 1 + 4 (4.2.58).

Using the pH meter (4.3.18.1), adjust the pH of this solution to $(12,5 \pm 0,5)$ with sodium hydroxide solution (4.2.31).

Add, without weighing, about 0,1 g of murexide (4.2.70), calcein indicator (4.2.71) or mixed calcein and methylthymol blue indicator (4.2.76). Place the beaker in the apparatus (4.3.12) set at 620 nm when using murexide or at 520 nm when using calcein and, while stirring the solution, titrate with the approximately 0,03 mol/l EDTA solution (4.2.66). In the vicinity of the colour change of the indicator, construct a curve of the absorbance values as a function of the volume of EDTA added. The volume V_{15} used is determined from the intersection of the line of greatest slope in the region of the colour change and the line of almost constant absorbance after the colour change.

4.5.14.4 Calculation and expression of results

Calculate the calcium oxide content in percent from the formula:

$$\text{CaO} = \frac{0,03 \times 56,08 \times 500 \times V_{15} \times f_D}{1000 \times 50 \times m_{23}} \times 100 = 1,6824 \times \frac{V_{15} \times f_D}{m_{23}} \quad (27)$$

where

V_{15} is the volume of the approximately 0,03 mol/l EDTA solution used for the titration, in millilitres;

f_D is the factor of the approximately 0,03 mol/l EDTA solution determined in accordance with 4.2.66.3;

m_{23} is the mass of the test portion used in 4.5.2 (m_{17}) or 4.5.5.2 (m_{20}), in grams.

4.5.14.5 Repeatability and reproducibility

The standard deviation for repeatability is 0,15 %.

The standard deviation for reproducibility is 0,43 %.

4.5.15 Determination of magnesium oxide by EDTA (alternative method)

4.5.15.1 General

This method uses photometric determination of the end-point. It is possible to determine the end-point of the titration visually. In this case mixed calcein and methylthymol blue indicator (4.2.76) (colour change from pink to colourless) or mixed indicator (4.2.78) (colour change from pink to colourless) or a dispersion of 1 g of phthalein purple in 100 g of solid NaCl (colour change from violet to pale pink) are suitable indicators.

4.5.15.2 Restriction on the method

In the rare case where a cement has a manganese oxide (Mn_2O_3) content greater than 0,5 %, only the method of determination of magnesium oxide by DCTA (4.5.13) is applicable.

4.5.15.3 Procedure

Pipette 50 ml of the solution prepared in accordance with 4.5.7 from the 500 ml volumetric flask into a beaker compatible with the measuring apparatus (4.3.12). Then dilute with water to a volume suitable for the correct operation of the equipment. Add 50 ml of the triethanolamine solution 1 + 4 (4.2.58).

Using the pH meter (4.3.18.1), adjust the pH of this solution to $(10,5 \pm 0,5)$ with ammonium hydroxide 1 + 1 (4.2.27).

Using a burette, add the volume V_{15} of EDTA solution (4.2.66) required for the titration of calcium oxide previously determined in 4.5.14.3.

Then add, without weighing, about 0,1 g of methylthymol blue (4.2.75), mixed calcein and methylthymol blue indicator (4.2.76) or mixed indicator (4.2.78).

Place the beaker in the apparatus (4.3.12) set at 620 nm and, while stirring the solution, titrate with the approximately 0,03 mol/l EDTA solution (4.2.66). In the vicinity of the colour change of the indicator, construct a curve of the absorbance values as a function of the volume of EDTA solution added. The volume V_{16} used is determined from the intersection of the line of greatest slope in the region of the colour change and the line of almost constant absorbance after the colour change.

4.5.15.4 Calculation and expression of results

Calculate the magnesium oxide content in percent from the formula:

$$\text{MgO} = \frac{0,03 \times 40,311 \times 500 \times (V_{16} - V_{15}) f_D}{1000 \times 50 \times m_{23}} \times 100 = 1,2093 \times \frac{(V_{16} - V_{15}) f_D}{m_{23}} \quad (28)$$

where

V_{15} is the volume of EDTA solution required for the determination of calcium oxide as in 4.5.14.3, in millilitres;

V_{16} is the volume of EDTA solution required for the determination of calcium oxide and magnesium oxide determined in 4.5.15.3, in millilitres;

f_D is the factor of the approximately 0,03 mol/l EDTA solution determined in accordance with 4.2.66.3;

m_{23} is the mass of the test portion used in 4.5.2 (m_{17}) or 4.5.5.2 (m_{20}), in grams.

4.5.15.5 Repeatability and reproducibility

The standard deviation for repeatability is 0,21 %.

The standard deviation for reproducibility is 0,25 %.

4.5.16 Determination of chloride

4.5.16.1 Principle

This method gives the total chloride plus bromide content and expresses the result as chloride ion (Cl^-). Cement is treated with boiling dilute nitric acid to decompose it and to remove sulfides. The dissolved chloride is precipitated using a known volume of a standard silver nitrate solution. After boiling, the precipitate is washed with dilute nitric acid and discarded. The filtrate and washings are cooled to below 25 °C and the residual silver nitrate is titrated with a standardised ammonium thiocyanate solution using an iron (III) salt as indicator.

4.5.16.2 Procedure

Weigh, to $\pm 0,0005$ g, ($5,00 \pm 0,05$) g of cement (m_{26}) and place in a 400 ml tall form beaker; add 50 ml of water and, while stirring with a glass rod, 50 ml of nitric acid 1 + 2 (4.2.14). Heat the mixture to boiling (in a fume cupboard for samples containing sulfide), stirring occasionally, and boil for 1 min to 2 min, avoiding loss of liquid. Remove from the source of heat and add 5 ml of silver nitrate solution (4.2.45) by pipette (4.3.17) into the solution. Then boil for not less than 1 min and not more than 2 min and filter through a coarse filter paper (4.3.16), washed before use with nitric acid 1 + 100 (4.2.15), into a 500 ml conical flask. Wash the beaker, glass rod and filter paper with nitric acid 1 + 100 until the volume of the filtrate and the washings is approximately 200 ml. Cool the filtrate and washings to below 25 °C in subdued light or in the dark.

Add up to 5 ml indicator solution (4.2.82) and titrate with the ammonium thiocyanate solution (4.2.80) shaking vigorously until a drop of this solution produces a faint pink colouration which does not disappear on shaking. Record the volume V_{17} of ammonium thiocyanate used in the titration. If V_{17} is less than 0,5 ml, repeat the procedure with half the sample mass.

Carry out the same procedure with no cement sample and record the volume, V_{18} , of ammonium thiocyanate solution used in the blank titration.

4.5.16.3 Calculation and expression of results

Calculate the chloride content in percent from the formula:

$$\text{Cl}^- = \frac{1,773 \times 5(V_{18} - V_{17})}{1000 \times V_{18} \times m_{26}} \times 100 = 0,8865 \times \frac{(V_{18} - V_{17})}{V_{18} \times m_{26}} \quad (29)$$

where

m_{24} is the mass of the test portion, in grams;

V_{17} is the volume of the ammonium thiocyanate solution used for the titration of the test solution, in millilitres;

V_{18} is the volume of the ammonium thiocyanate solution used for the titration of the blank solution, in millilitres.

4.5.16.4 Repeatability and reproducibility

The standard deviation of repeatability is 0,005 %.

The standard deviation of reproducibility is 0,010 %.

4.5.17 Determination of carbon dioxide (reference method)

4.5.17.1 Principle

The cement is treated with phosphoric acid to decompose the carbonate present. The carbon dioxide liberated is entrained in a current of carbon dioxide-free gas or air through a series of absorption tubes. The first two remove hydrogen sulfide and water and the following absorb carbon dioxide. Two absorption tubes, each containing a granular absorbent for carbon dioxide and anhydrous magnesium perchlorate to retain the water formed during the absorption reaction are weighed to determine the mass of carbon dioxide released.

4.5.17.2 Apparatus

A typical apparatus (4.3.19) is shown in Figure 2.

4.5.17.3 Procedure

Weigh, to $\pm 0,0005$ g ($1,00 \pm 0,05$) g of cement (m_{27}) and place it in a dry 100 ml distillation flask. Connect the flask to the apparatus (4.3.19) as shown in Figure 2, but without the two absorption tubes (13). Pass a current of carbon dioxide-free gas through the apparatus for 15 min at approximately three bubbles per second (bubble counter) via the connecting tube onto (6) (branch onto (5), Mohr clip closed). Release the Mohr clip and remove the gas supply from the funnel (4). Add 30 ml concentrated phosphoric acid (4.2.20) into the dropping funnel and reconnect the gas supply to fill the funnel (4).

Condition the closed absorption tubes (13) for 15 min in the balance case in order to achieve temperature equilibrium. Then weigh each tube separately. Shut off the flow of gas and attach the tubes to the apparatus as shown in Figure 2.

Care should be taken when handling the tubes to avoid affecting their weight, causing damage or sustaining injury. It is advisable to wear protective gloves when carrying out this operation.

Reopen the gas flow. After 10 min close absorption tubes (13), remove them, place them in the balance case for 15 min and then weigh them separately. Repeat the passage of gas, removal and weighing of absorption tubes (13) for as long as is required for the results of two successive weighings of a tube not to differ by more than 0,0005 g.

If the change in mass of the absorption tubes (13) remains greater than 0,0005 g, renew the absorbents in tubes (11) and (12).

Attach the weighed absorption tubes (13) to the apparatus, as shown in Figure 2.

Open the funnel tap and allow the phosphoric acid to drop into the distillation flask (14). After the reaction has ceased, heat the contents of the flask to boiling and boil gently for 5 min. Maintain the gas flow through the apparatus until the flask has cooled to room temperature.

Close absorption tubes (13), remove them and place them in the balance case for 15 min and then weigh them separately. The increase in mass of each tube is used for the calculation of the carbon dioxide content (see 4.5.17.4).

The carbon dioxide is practically completely absorbed by first tube (13). If the increase in mass of second tube (13) exceeds 0,0005 g, renew the absorbent in first tube (13) and start the test again.

4.5.17.4 Calculation and expression of results

Calculate the carbon dioxide content as a percentage of the cement from the formula:

$$\text{CO}_2 = \frac{m_{28} + m_{29}}{m_{27}} \times 100 \quad (30)$$

where

- m_{27} is the mass of the test portion, in grams;
- m_{28} is the increase in mass of first tube (13) after absorption, in grams;
- m_{29} is the increase in mass of second tube (13) after absorption, in grams.

If the carbon dioxide content calculated from Formula (30) is less than 0,5 %, repeat the determination with $(2,00 \pm 0,05)$ g of cement, weighed to $\pm 0,0005$ g. Alternatively, where the cement contains a high proportion of carbonate, the size of the sample should be decreased appropriately.

4.5.17.5 Repeatability and reproducibility

The standard deviation of repeatability is 0,07 %.

The standard deviation of reproducibility is 0,10 %.

4.5.18 Determination of carbon dioxide (alternative method)

4.5.18.1 Principle

The carbon dioxide is driven off by treatment with sulfuric acid, absorbed by sodium hydroxide and determined gravimetrically. Any hydrogen sulfide present which may affect the results is absorbed by mercuric (II) chloride.

4.5.18.2 Apparatus

The apparatus (4.3.20) is shown in Figure 3. A small vacuum pump is used to generate reduced pressure in the apparatus.

4.5.18.3 Procedure

Weigh, to $\pm 0,0005$ g, $(1,00 \pm 0,05)$ g of cement (m_{30}) into the 100 ml distillation flask (7) of the apparatus (4.3.20). Mix this cement with a small (about 50 mg) amount of mercuric (II) chloride (4.2.88) using a spatula and then add enough water to form a slurry. Connect the flask to the ground joint of the dropping funnel (1). Then draw air for 15 min through the apparatus, passing the air through an absorption tower (8) filled with absorbent (4.2.87) to remove the carbon dioxide before the air passes into the flask.

Condition the closed absorption tubes (4) for 15 min in the balance case in order to achieve temperature equilibrium. Then weigh each tube separately. Shut off the flow of gas and attach the tubes to the apparatus as shown in Figure 3.

Care should be taken when handling the tubes to avoid affecting their weight, causing damage or sustaining injury. It is advisable to wear protective gloves when carrying out this operation.

Add 25 ml to 30 ml of sulfuric acid 1 + 4 (4.2.18) from the dropping funnel (1) into the flask. Take care to ensure that some of the acid remains in the dropping funnel as a seal.

Turn the vacuum pump on again, so that the current of air carries the liberated carbon dioxide through the condenser (2) and the first two absorption tubes (3), filled with magnesium perchlorate (4.2.86) for the purposes of drying the air, to the two previously weighed absorption tubes (4) filled with absorbents (4.2.86 and 4.2.87). An absorption tube (5) filled with magnesium perchlorate (4.2.86) and absorbent (4.2.87) is fitted

after these tubes in order to prevent penetration by the ambient air. Gas washing bottle (9) empty and (10), filled with concentrated sulfuric acid (4.2.16) or paraffin, as a bubble counter are connected.

After about 10 min, heat the contents of the flask to boiling and boil gently for 5 min. Maintain the air flow through the apparatus until the flask has cooled to room temperature. Close the taps and remove the absorption tubes (4), place them in the balance case for 15 min in order to achieve temperature equilibrium and then weigh them.

4.5.18.4 Calculation and expression of results

Calculate the carbon dioxide content in percent from the formula:

$$\text{CO}_2 = \frac{m_{31} \times 100}{m_{30}} \quad (31)$$

where

m_{30} is the mass of the test portion, in grams;

m_{31} is the increase in mass of the absorption tubes (4) after absorption, in grams.

If the carbon dioxide content calculated from Formula (31) is less than 0,5 %, repeat the determination with $(2,00 \pm 0,05)$ g of cement, weighed to $\pm 0,0005$ g. Alternatively, where the cement contains a high proportion of carbonate the size of the sample should be decreased appropriately.

4.5.18.5 Repeatability and reproducibility

The standard deviation of repeatability is 0,07 %.

The standard deviation of reproducibility is 0,10 %.

4.5.19 Determination of alkali (reference method)

4.5.19.1 Principle

A butane, propane or acetylene flame is used to excite the alkali metals to emit their characteristic spectrum in the visible range. The emission is proportional to the alkali content at low concentrations. The influence of large quantities of calcium in the sample on the sodium determination is suppressed by means of phosphoric acid. The influence of phosphoric acid on the potassium emission from the calibration solutions is suppressed by adding calcium to the calibration solutions.

4.5.19.2 Reagents

Whenever a new batch of any reagent is used, determine the alkali content by means of this method. If the alkali content of a reagent exceeds 0,01 %, either replace the batch with a new one, which shall be verified in the same way, or prepare new calibration solutions.

4.5.19.3 Preparation of calibration solutions and calibration curves

Prepare the calibration solutions using the volumes of alkali stock solution, acid stock solution and calcium stock solution listed in Table 4. Make up the volumes listed in lines 1 to 7 to 1 000 ml with water and mix thoroughly. Store these calibration solutions in polyethylene bottles. Spray the calibration solutions into the flame of the flame photometer (4.3.21). Spray the blank solution (Table 4, S1) first and set the indication on the apparatus to zero. Spray the solution of greatest concentration (S7) and set the indication on the apparatus to maximum intensity. Spray the other calibration solutions in the order of increasing concentration (S2 to S6). Measure the intensities for Na_2O at 589 nm and for K_2O at 768 nm.

Construct curves of the measured intensities against the corresponding concentrations of Na₂O and K₂O in the calibration solutions.

Table 4 — Volumes of solutions for the preparation of calibration solutions and their sodium oxide and potassium oxide concentrations

Calibration solution	Alkali stock solution (4.2.89) ml	Acid stock solution (4.2.90) ml	Calcium stock solution (4.2.91) ml	Na ₂ O and K ₂ O concentrations mg/l
S1	-	100	100	0,0
S2	5	100	100	1,5
S3	10	100	100	3,0
S4	20	100	100	6,0
S5	30	100	100	9,0
S6	40	100	100	12,0
S7	50	100	100	15,0

4.5.19.4 Dissolution of the test portion

4.5.19.4.1 Cements with an insoluble residue not exceeding 3 %

NOTE This method is applicable to cements which have an insoluble residue content, determined in accordance with Clause 9, not exceeding 3 %.

Weigh (0,500 0 ± 0,000 5) g of cement into a 250 ml beaker, make into a slurry with 50 ml of water and add 50 ml of hydrochloric acid 1 + 19 (4.2.8). Warm the mixture until the cement has decomposed, crushing any lumps with a glass rod. Then allow the suspension to cool to ambient temperature. Transfer the contents of the beaker, rinsing the beaker with water, into a 500 ml volumetric flask. Add 50 ml of phosphoric acid 1 + 19 (4.2.21), make up to the mark with water and mix thoroughly. Filter, without washing, sufficient solution through the filter paper (4.3.23) into a clean, dry beaker, before spraying solution into the flame.

4.5.19.4.2 Cements with an insoluble residue exceeding 3 %

WARNING 1 Carry out the following evaporation procedures in an appropriate fume cupboard (see WARNING 2) because the vapours from nitric acid (4.2.13), perchloric acid (4.2.19) and hydrofluoric acid (4.2.11) are hazardous. In addition, wear eye protection and suitable rubber or plastics gloves when handling or agitating these acids or their mixtures.

Where the content of insoluble residue, determined in accordance with 4.4.3, exceeds 3 %, the method described below should be used.

Weigh (0,500 0 ± 0,000 5) g of cement into a platinum dish (4.3.22) and add 15 ml of nitric acid (4.2.13). Heat the mixture, e.g. on a hot-plate, and evaporate to dryness. Disperse the residue from evaporation in 15 ml of water, add 5 ml of perchloric acid (4.2.19) and then add 25 ml of hydrofluoric acid (4.2.11).

WARNING 2 Perchloric acid vapours form explosive mixtures with organic materials. It is therefore necessary to take special precautionary measures when working with perchloric acid, e.g. the use of fume cupboards flushed with water and a general ban on the use of organic substances in the same fume cupboard.

Heat the mixture and evaporate to dryness. Prevent overheating by frequent agitation by means of the HF resistant stirrer (4.3.24). Add 10 ml of water and 50 ml of hydrochloric acid 1 + 19 (4.2.8) to the residue from evaporation and heat until the residue has dissolved. Allow the suspension to cool to room temperature. Transfer the contents of the platinum dish, rinsing the dish with water, into a 500 ml volumetric flask. Add 50 ml of phosphoric acid 1 + 19 (4.2.21) to the solution, make up to the mark with water and mix thoroughly.

Filter, without washing, sufficient solution through the filter paper (4.3.23) into a clean, dry beaker, before spraying solution into the flame.

4.5.19.5 Procedure

Spray the sample solution produced as described in 4.5.19.4.1 or 4.5.19.4.2 into the flame of the flame photometer (4.3.21). Measure the intensity of the sodium line at 589 nm and the potassium line at 768 nm. Obtain the sodium oxide or potassium oxide concentration in the solution respectively by means of a linear interpolation from the intensities and the associated concentrations of the calibration solutions measured as described in 4.5.19.3.

Use the curves constructed in accordance with 4.5.19.3 to obtain the sodium oxide and potassium oxide concentrations of the solution in mg/l or use the intensities and the associated concentrations of the calibration solutions with the next higher and the next lower intensity for the calculation as follows.

Calculate the sodium oxide $C_{\text{Na}_2\text{O}}$ or potassium oxide $C_{\text{K}_2\text{O}}$ concentration of the sample from the intensities $I_{\text{Na}_2\text{O}}$ or $I_{\text{K}_2\text{O}}$ respectively using the following formulae:

$$C_{\text{Na}_2\text{O}} = C_{\text{Bn}} + (C_{\text{Bh}} - C_{\text{Bn}}) \times \frac{I_{\text{Na}_2\text{O}} - I_{\text{Bn}}}{I_{\text{Bh}} - I_{\text{Bn}}} \quad (32)$$

$$C_{\text{K}_2\text{O}} = C_{\text{Bn}} + (C_{\text{Bh}} - C_{\text{Bn}}) \times \frac{I_{\text{K}_2\text{O}} - I_{\text{Bn}}}{I_{\text{Bh}} - I_{\text{Bn}}} \quad (33)$$

where

C_{Bn} is the concentration of the sodium oxide or potassium oxide respectively in the calibration solution having a lower concentration than the sample solution, in milligrams per litre;

C_{Bh} is the concentration of the sodium oxide or potassium oxide respectively in the calibration solution having a higher concentration than the sample solution in milligrams per litre;

I_{Bn} is the intensity of the calibration solution having a lower concentration than the sample solution;

I_{Bh} is the intensity of the calibration solution having a higher concentration than the sample solution.

4.5.19.6 Calculation and expression of results

4.5.19.6.1 Sodium oxide and potassium oxide content

Calculate the sodium oxide or potassium oxide content in percent from the following formulae using the corresponding concentrations as determined in accordance with 4.5.19.5.

$$\text{Na}_2\text{O} = 0,1 \times C_{\text{Na}_2\text{O}} \quad (34)$$

$$\text{K}_2\text{O} = 0,1 \times C_{\text{K}_2\text{O}} \quad (35)$$

where

$C_{\text{Na}_2\text{O}}$ is the sodium oxide concentration of the sample solution as calculated by Formula (32), in milligrams per litre;

C_{K_2O} is the potassium oxide concentration of the sample solution as calculated by Formula (33), in milligrams per litre.

4.5.19.6.2 Sodium oxide equivalent

Calculate the sodium oxide equivalent content in percent by converting the potassium oxide content to the equivalent sodium oxide content and adding the measured sodium oxide content using the formula:

$$\text{Sodium oxide equivalent} = Na_2O + 0,658 K_2O \quad (36)$$

NOTE The sodium oxide equivalent, determined in accordance with this standard, is sometimes referred to as the acid soluble alkali content to differentiate from determinations carried out using other extraction methods e.g. water soluble alkali content.

4.5.19.7 Repeatability and reproducibility

The standard deviation of repeatability is:

0,01 % for the determination of Na_2O ;

0,02 % for the determination of K_2O .

The standard deviation of reproducibility is:

0,02 % for the determination of Na_2O ;

0,03 % for the determination of K_2O .

4.5.20 Determination of alkali (alternative method)

4.5.20.1 Principle

Cements, with an insoluble residue not exceeding 3 %, determined in accordance with 4.4.3, are treated with hydrochloric acid. Cements, with an insoluble residue greater than 3 %, are first evaporated with hydrofluoric acid/sulfuric acid. The alkali contents of the solutions are determined by means of flame photometry.

4.5.20.2 Reagents

Whenever a new batch of any reagent is used, determine the alkali content by means of this method. If the alkali content of a reagent exceeds 0,01 % either replace the batch with a new one, which shall be verified in the same way or prepare new calibration solutions.

4.5.20.3 Construction of the calibration curves

In the case of cements with an insoluble residue not exceeding 3 %, evaporate 20 ml of hydrochloric acid 1 + 9 (4.2.6) to dryness. In the case of cements with an insoluble residue greater than 3 %, evaporate 15 ml of hydrofluoric acid (4.2.11) and 5 ml of sulfuric acid (4.2.16) to dryness for the purposes of preparing the calibration solutions for each calibration point.

In both cases, dissolve the residue from evaporation with 2 ml of hydrochloric acid 1 + 9 (4.2.6) and 3 ml of water. Transfer the solution to a 100 ml volumetric flask and add 10 ml of buffer solution (4.2.95). Add the quantities of the alkali stock solution (4.2.92) to the individual volumetric flasks shown in Table 5 using a burette (4.3.17).

Table 5 — Quantities of stock solution to be added to flasks

Volumetric flasks	1	2	3	4	5	6	7
Stock solution (ml)	0	1	3	5	10	20	30

Then make up the volumetric flasks to the mark with water.

For an original test portion of 0,200 0 g, the values measured for flasks 1 to 7 correspond to the Na₂O and K₂O contents shown in Table 6:

Table 6 — Alkali contents of stock solutions in flasks

Volumetric flasks	1	2	3	4	5	6	7
Na ₂ O content (%)	0	0,07	0,20	0,34	0,67	1,35	2,02
K ₂ O content (%)	0	0,06	0,18	0,30	0,60	1,20	1,81

Spray the calibration solutions into the flame of the flame photometer (4.3.21). Spray the blank solution 1 first and set the indication on the apparatus to zero.

Then spray the other calibration solutions in order of increasing alkali content (2 to 7). Measure the intensities for Na₂O at 589 nm and for K₂O at 768 nm. Construct curves of the measured intensities against the corresponding contents of sodium oxide and potassium oxide in the calibration solutions.

4.5.20.4 Procedure

4.5.20.4.1 Cements with an insoluble residue not exceeding 3 %

NOTE This procedure is applicable to cements which have an insoluble residue content, determined in accordance with 4.4.3, not exceeding 3 %.

Weigh, to $\pm 0,000 5$ g, ($0,200 0 \pm 0,005$) g of cement into the platinum dish (4.3.22), make into a slurry with 3 ml of water and evaporate to dryness after adding 20 ml of hydrochloric acid 1 + 9 (4.2.6). Add hot water and 2 ml of hydrochloric acid 1 + 9 to the residue and filter through the filter paper (4.3.23) into a 100 ml volumetric flask which already contains 10 ml of the buffer solution (4.2.95). Wash the residue with hot water until the volumetric flask is almost filled to the mark. Then cool to room temperature and make up to the mark with water.

Measure the solution in the flame photometer (4.3.21). The scale values read off in conjunction with the calibration curves (4.5.20.3) give the contents of Na₂O and K₂O in percent respectively, uncorrected in the case where a test portion different in mass from 0,200 0 g has been taken (see 4.5.20.3 and 4.5.20.5).

4.5.20.4.2 Cements with an insoluble residue exceeding 3 %

WARNING Carry out the following evaporation procedures in an appropriate fume cupboard because the vapours from sulfuric acid (4.2.16) and hydrofluoric acid (4.2.11) are hazardous. In addition, wear eye protection and suitable rubber or plastics gloves when handling or agitating these acids or their mixtures.

Where the content of insoluble residue, determined in accordance with 4.4.3, exceeds 3 %, the procedure described below should be used.

Weigh, to $\pm 0,000 5$ g, ($0,200 \pm 0,005$) g cement into the platinum dish (4.3.22). Make into a slurry with 3 ml of water and evaporate after adding 5 ml of sulfuric acid (4.2.16) and 15 ml of hydrofluoric acid (4.2.11). Evaporate to dryness under the heating lamp (4.3.25). Mix the residue with hot water and 2 ml of hydrochloric acid 1 + 9 (4.2.6) and continue the procedure, from the filtering operation onwards, as described in 4.5.20.4.1.

4.5.20.5 Calculation and expression of results

Calculate the content of each alkali oxide as a percentage for an original test portion of 0,200 0 g by dividing each value obtained, in percent, at 4.5.20.4.1 (or 4.5.20.4.2), by the actual mass of the test portion and multiplying by 0,2.

Express the result as described in 4.5.19.6.

4.5.20.6 Repeatability and reproducibility

The standard deviation of repeatability is:

0,01 % for the determination of Na_2O ;

0,02 % for the determination of K_2O .

The standard deviation of reproducibility is:

0,02 % for the determination of Na_2O ;

0,03 % for the determination of K_2O .

5 Chemical analysis by X-ray fluorescence

5.1 Reagents and reference materials

5.1.1 Pure reagents

Reagents shall be of analytical quality and, wherever possible, pure oxides or carbonates, except for the calibration of such elements as sulfur, chlorine, bromine or phosphorus, which do not form stable oxides or carbonates, where some guarantee of stoichiometry is required.

Reagents shall be free of (or corrected for) the presence of water (and, in the case of oxides, carbon dioxide) when weighed out for fusion. Furthermore, the reagents shall be in a known oxidation state. The specified procedure ensures that the correct oxidation state is obtained.

The reagents used to prepare the standard beads for calibrations shall be pure oxides or carbonates of at least 99,95 % purity (excluding moisture or CO_2).

Reagents shall be used in a known stoichiometry in terms of content. In order to achieve this, they can be treated before use as follows.

- a) Determine the loss on ignition for silicon dioxide (SiO_2), aluminium oxide (Al_2O_3) and magnesium oxide (MgO) as follows:
 - 1) Ignite the reagent at, for example, $(1\,175 \pm 25)^\circ\text{C}$ and maintain at this temperature for 30 min.
 - 2) Cool in a desiccator to room temperature and reweigh.
 - 3) After allowing for this loss, weigh the appropriate amount of the unignited material to prepare the bead.
- b) Dry manganese oxide (Mn_2O_3) and titanium(IV) oxide (TiO_2) as follows:
 - 1) Ignite the reagent at, for example, $(1\,000 \pm 25)^\circ\text{C}$ and maintain at this temperature for 30 min.
 - 2) Cool in a desiccator to room temperature before use.

c) Dry iron (III) oxide (Fe_2O_3) as follows:

- 1) Ignite the reagent at, for example, $(700 \pm 25)^\circ\text{C}$ and maintain at this temperature for 30 min.
- 2) Cool in a desiccator to room temperature before use.

d) Dry calcium carbonate (CaCO_3), strontium carbonate (SrCO_3), potassium carbonate (K_2CO_3) and sodium carbonate (Na_2CO_3).

- 1) Heat the reagent at, for example, $(250 \pm 10)^\circ\text{C}$ and maintain at this temperature for 2 h.
- 2) Cool in a desiccator to room temperature before use.

5.1.2 Reference materials

5.1.2.1 Certified reference materials

Certified reference materials (CRMs) are materials, e.g. cement, supplied by an organisation conforming to the requirements for the competence of reference material producers in accordance with ISO Guide 30.

CRMs shall be supplied with a certificate of analysis giving information on the average value and standard deviation in accordance with ISO Guide 31.

5.1.2.2 Industrial reference materials

Industrial reference materials (IRMs) are materials, e.g. cement, prepared and homogenised by a laboratory. The reference analysis of an IRM shall be the average result from inter-laboratory co-operative testing involving at least four laboratories able to meet the performance criteria given in 5.7.3.

5.1.3 Calibration standards

Calibration standards are prepared in the laboratory from pure, analytical-grade reagents, IRMs, CRMs or a combination of these. They shall be formulated to provide a series of calibration standards covering the range of maximum to minimum values for each element being analysed and shall be evenly distributed between those limits. The variation in concentrations of the elements shall be independent of each other. There shall be a minimum of seven calibration standards in a series.

5.1.4 Binding agent

A binding agent, e.g. wax, whose influence on the elements being analysed has been determined, is used in the grinding of samples during the preparation of pressed pellets. Carry out a pellet-preparation monitoring check (see 5.7.5) whenever the batch of binding agent is changed.

5.2 Apparatus

5.2.1 Balance, capable of weighing to an accuracy of $\pm 0,0005$ g.

5.2.2 Fusion vessels and casting moulds, of a non-wetted platinum alloy, such as Pt/5 % Au or Pt/Rh.

Vessels that serve both as a fusion vessel and as a casting mould (i.e. a combined fusion mould) may be used. If moulds become distorted in use, then they shall be reshaped by pressing in a suitable former. If the bottom (flat) surface of the bead is used for analysis, it is necessary that the internal base of the mould also be kept flat and free from blemishes.

NOTE Cleanliness of fusion vessels is important in achieving accurate analyses. This can be achieved, for example, by boiling in dilute hydrochloric acid, 1:10 by volume or citric acid, 100 g/l.

5.2.3 Lids, optional, of a platinum alloy (not necessarily non-wetted).

5.2.4 Furnace, e.g. an electric resistance, muffle or high-frequency induction furnace, capable of operating at $(250 \pm 10) ^\circ\text{C}$, $(700 \pm 25) ^\circ\text{C}$, $(950 \pm 25) ^\circ\text{C}$, $(1\ 000 \pm 25) ^\circ\text{C}$ and $(1\ 175 \pm 25) ^\circ\text{C}$.

5.2.5 Automatic fusion apparatus, for use in automatic bead preparation (see 5.6.4).

An automatic fusion apparatus may be used, provided that the performance criteria in 5.7.3 can be met.

5.2.6 Cooling apparatus, consisting of any device, such as a narrow jet of air that can be directed to the centre of the base of the casting mould (for example, by the base of a bunsen burner without a barrel) or a water-cooled metal plate.

NOTE Normally, cooling in air is sufficient but some difficult samples can require a cooling apparatus in order to cool the melt rapidly. This is necessary to obtain a homogeneous bead and to free the melt from the casting mould.

5.2.7 Heat reservoir, for the casting mould, required in special circumstances when using moulds of small sizes, so that the mould does not cool too rapidly when removed from the furnace.

5.2.8 Spectrometer, X-ray fluorescence, capable of meeting the performance criteria given in 5.7.3.

NOTE It is important to set appropriate measuring conditions to satisfy the performance criteria based on the type of samples, the type of apparatus, elements being analysed and their content, etc.

5.2.9 Flow gas, maintained at as constant a room temperature as possible.

The temperature of the flow gas cylinder and of the connecting pipework is critical in order to prevent drift in sensitivity of the flow proportional counters. Pipework shall be as short as practical and run, whenever possible, within the temperature-controlled room in which the spectrometer is housed. Where this is not possible, the cylinder shall be kept in a temperature-controlled cabinet (room temperature $\pm 2 ^\circ\text{C}$) or otherwise maintained at a constant room temperature. For the same reason, new cylinders shall be allowed to equilibrate for at least 2 h to room temperature before use.

NOTE The flow gas is used in the gas flow proportional counter of the XRF spectrometer.

The composition of gas can change as the cylinder becomes exhausted. Cylinders should be replaced before they become completely empty.

5.2.10 Grinding equipment, capable of grinding the sample, with binding agent if necessary, to a suitable fineness.

5.2.11 Pellet press, capable of applying a pressure suitable for production of pellets with a consistent, consolidated surface to meet the performance requirements given in 5.7.3.

5.2.12 Mould, usually of steel, of suitable strength to withstand the press without distortion and of suitable size to produce a pellet to fit the spectrometer.

5.3 Flux

5.3.1 Choice of flux

5.3.1.1 General

One of the advantages of the XRF fused cast bead method is that a wide variety of fluxes may be chosen. For a given calibration, the same flux shall be used throughout. The conditions given in 5.3.1.2 to 5.3.1.4 shall be met for any flux used.

NOTE 1 Fluxes used with success in the analysis of cement are given in Annex A. Pre-fused fluxes have the advantage of a lower moisture content.

NOTE 2 Reducing the particle size of the flux has been shown to improve fusion at a given temperature.

5.3.1.2 Dissolution

Under the conditions of preparation used, the sample shall be totally dissolved by the flux and shall not come out of solution in the casting procedure.

5.3.1.3 Heavy-element absorber

A heavy-element absorber, such as lanthanum or vanadium oxide, may be incorporated into the flux, provided:

- a) it does not reduce sensitivities to the point that the performance criteria given in 5.7.3 cannot be met;
- b) the heavy element does not have a line overlap with any of the elements being determined.

NOTE Lanthanum oxide assists the formation and stabilisation of glass but reduces the intensity of the emitted X-rays.

WARNING There are restrictions on the use of heavy-metal chemicals in some countries. Care should be taken in the handling of these and national safety rules observed.

5.3.1.4 Flux purity

The flux shall be pure with respect to the elements being determined.

Most reagents sold as “flux” grade quality by reputable manufacturers meet this requirement, but an analysis shall be obtained for each batch of flux supplied. Carry out a bead-preparation monitoring check (see 5.7.5) when a batch of flux is changed.

5.3.2 Moisture in flux

Pre-molten fluxes having a loss on ignition not exceeding 0,50 % mass fraction are preferred. However, if the flux contains moisture, it shall be dried at a suitable temperature.

5.3.3 Flux-to-sample ratio

The flux-to-sample ratio selected shall be such that the performance criteria given in 5.7.3 are met. The mass fraction ratio, R , of flux to sample used for the calibration shall be used for subsequent analyses.

NOTE As the flux-to-sample mass fraction ratio is greater than one, impurities in the flux can have a negative influence on the measured result. The greater the ratio of the flux to sample, the greater the influence.

The total mass of sample and flux shall be chosen for the particular casting mould type used, and this mass shall always remain the same.

5.3.4 Anti-wetting agent

A small amount of anti-wetting agent may be used, if necessary. An anti-wetting agent, such as lithium bromide, ammonium bromide, lithium iodide, lithium iodate or ammonium iodide, may be added to the melt to assist in preventing the cracking of the fused beads on cooling and to aid in the release from the mould. Where an anti-wetting agent is used, all beads shall be prepared using the same anti-wetting agent added in the same quantity and at the same stage of bead preparation.

NOTE Bromine or iodine in the anti-wetting agent can remain in the bead under some fusing conditions. It is important to check for residual bromine or iodine, since these elements can cause line overlapping, such as Br L α on Al K α or I L β 2 on Ti K α .

5.4 Determination of loss on ignition and the change in mass on fusion of the cement

5.4.1 Principle

In order to be able to total (to 100 % mass fraction) any oxide analysis of cement, the determination of the loss on ignition, i.e. the amount of any combined water and carbon dioxide, is required. In addition, in order to be able to convert an oxide analysis obtained on the fused-basis using fused-bead XRF, to an oxide analysis on the as-received basis, an “observed” loss on ignition is also required.

NOTE Where the sample contains no oxidisable species, the loss on ignition and the “observed” loss on ignition are the same.

The “observed” loss on ignition (see 5.4.3.1) is a very close approximation to the “change in mass on fusion” that occurs when a sample is prepared as a fused bead for analysis by XRF. This “observed” loss on ignition is used in this method to calculate a factor, f , (see 5.5) to convert test results obtained on the fused basis to the as-received basis.

The traditional loss-on-ignition determination carried out in an oxidising atmosphere by igniting in air can be used to determine both the loss on ignition and the “observed” loss on ignition. Where any oxidisable species are present, in particular sulfide or sulfur-containing species, a correction can be applied to the “observed” loss in order to derive a “corrected” loss on ignition for use in totalling the oxide analysis. However, any error resulting from the oxidation of any metallic iron, bivalent iron or bivalent manganese is usually considered to be negligible and only the correction for the extent of oxidation of sulfides is applied in the correction.

An alternative method, e.g. automatic equipment, may be used, provided that it can be demonstrated that the performance criteria given in 5.7.3 are satisfied.

5.4.2 Procedure

Weigh, to $\pm 0,0005$ g, ($1,00 \pm 0,05$) g of cement into a crucible which has been previously ignited and tared. Record this mass as m_1 . Place the covered crucible in the furnace (5.2.4) controlled at (950 ± 25) °C. After heating for 5 min, remove the lid and leave the crucible in the furnace for a further 10 min. Allow the crucible to cool to room temperature in a desiccator. Determine constant mass by making successive 15 min ignitions followed each time by cooling and then weighing, and record as m_2 . Constant mass is reached when the difference between two successive weighings is less than 0,0005 g.

NOTE For cements containing sulfides, a more accurate determination of the loss on ignition can be obtained by determining the sulfate content before and after ignition. The correction applicable to these cements is given in 5.4.3.2.

When vacuum desiccators are used, the appropriate desiccator inlet trap should be used when any vacuum is released. Phosphorus pentoxide should be avoided where surface-active materials are being stored, since P_2O_5 can be absorbed by the sample, particularly under vacuum conditions.

5.4.3 Calculation and expression of results

5.4.3.1 Observed loss on ignition

Calculate the observed loss on ignition (i.e. the change in mass on fusion), L , expressed as a percentage mass fraction, as given in Formula (37):

$$L = \frac{m_1 - m_2}{m_1} \times 100 \quad (37)$$

where

m_1 is the mass of the test portion, expressed in grams;

m_2 is the mass of the ignited test portion, expressed in grams.

5.4.3.2 Correction to the observed loss on ignition for the oxidation of sulfides

Calculate the correction to the “observed” loss on ignition for the extent of oxidation of sulfides, by determining the sulfate present before and after ignition (see 4.4.2).

The amount of SO₃, $w_{S,up}$, resulting from the oxidation of sulfides, expressed as a percentage mass fraction, is calculated as given in Formula (38):

$$w_{S,up} = w_{S,f} - w_{S,i} \quad (38)$$

where

$w_{S,f}$ is the final SO₃ value, expressed as a percentage mass fraction;

$w_{S,i}$ is the initial SO₃ value, expressed as a percentage mass fraction.

A correction, $w_{O,up}$, for the oxygen taken up by the test portion, expressed in percent, is given by Formula (39):

$$w_{O,up} = 0,8 w_{S,up} \quad (39)$$

The corrected loss on ignition, L_{cor} , is calculated as given in Formula (40):

$$L_{cor} = L + w_{O,up} \quad (40)$$

where

L is the observed loss on ignition, expressed as a percentage mass fraction.

Indicate any corrections applied in the test report.

5.4.4 Repeatability and reproducibility for loss on ignition

The standard deviation for repeatability is 0,04 % mass fraction.

The standard deviation for reproducibility is 0,08 % mass fraction.

5.5 Factoring test results and correcting total analyses for presence of sulfides and halides

5.5.1 General

Analyses may be carried out on a fused-bead or pressed-pellet test portion. In the case of analysis using fused beads, it is necessary to determine the change in mass that occurs during fusion (see 5.4.3.1) in order to derive a multiplying factor for converting test results obtained on the fused basis to analytical results reported on the as-received basis.

In addition, where sulfide, chloride or bromide are present, it is also necessary to correct the total oxide analysis of a cement for the fact that, traditionally, these species are also expressed as if they were oxygen (combined with calcium) in the analytical result reported for calcium oxide. This latter correction also applies to analyses carried out using pressed pellets.

5.5.2 Factoring test results obtained from fused-bead analysis

5.5.2.1 Principle

Where fusion is employed, it is necessary to determine the change in mass that occurs during fusion in order to derive a multiplying factor for converting test results obtained on the fused basis to analytical results on the as-received basis.

The change in mass that occurs during fusion is determined by igniting, in air, a weighed test portion to constant mass at (950 ± 25) °C and calculating the “observed” loss on ignition; see 5.4.3.

NOTE 1 The change in mass occurring during fusion in air is normally a loss as, generally, water and carbon dioxide are released. Where, however, the sample contains oxidisable species, there is an increase in mass of these species during fusion resulting from oxygen uptake. This might or might not lead to an overall increase in mass of the test portion depending on the balance of mass lost versus mass gained. The oxidisable species that can lead to an overall gain in mass of a test portion is sulfur, generally present as sulfide (typically calcium sulfide) in test portions that contain a blast-furnace slag constituent. Other oxidisable species, where present, such as metallic iron, bivalent iron or bivalent manganese, are generally present in small amounts and make only a minor contribution to mass change.

NOTE 2 The presence of sulfide in a sample also leads to restrictions on the scope of the analysis that can be undertaken using the XRF technique based upon fused beads. In particular, sulfate (SO_3) cannot be determined directly from such a fused bead because of the contribution to the concentration from the unknown amount of sulfide. In addition, sulfide cannot be determined directly (or accurately, indirectly) because of the contribution of the unknown amount of sulfate to the analysis and from the possibility that some sulfide could have been lost by volatilisation during fusion. Consequently, the method of 4.4.5, is the reference method for determining the sulfate content of samples containing sulfide species.

5.5.2.2 Calculating the factor for converting the results obtained using fused beads

Calculate the factor, f_{LOI} , for converting test results obtained on the fused basis to analytical results on the as-received basis, from the observed loss on ignition, L , (see 5.4.3.1) as given in Formula (41):

$$f_{\text{LOI}} = \left(\frac{100 - L}{100} \right) \quad (41)$$

Where L is expressed as a percentage mass fraction.

When L is a negative number, which occurs when the test portion has undergone an overall gain in mass, preserve the sign together with L in Formula (41).

5.5.2.3 Use of the conversion factor, f_{LOI}

Convert all test results obtained on the fused basis to analytical results on the as-received basis by multiplying each result by the factor, f_{LOI} .

5.5.3 Correcting total oxide analysis for sulfides and halides

5.5.3.1 Correcting total oxide analysis for sulfides

Irrespective of whether the analysis was carried out on a fused (bead) or pressed (pellet) test portion, determine the sulfide content of the cement, on the as-received basis, in accordance with the method for sulfide determination in 4.4.5.

The factor, f_{S} , to correct the total analysis of cement containing sulfide species, is calculated as given in Formula (42):

$$f_{\text{S}} = w_{\text{S}^{2-}} + L_{\text{cor}} + w_{\text{O,tot}} - w_{\text{O,S}^{2-}} \quad (42)$$

where

$w_{\text{S}^{2-}}$ is the sulfide content, expressed as a percentage mass fraction;

L_{cor} is the “corrected” loss on ignition, expressed as a percentage mass fraction; (see 5.4.3.2);

$w_{\text{O,tot}}$ is the sum of all oxides, expressed as a percentage mass fraction; (see 3.3);

$w_{\text{O,S}^{2-}}$ is the oxygen equivalent of sulfide, expressed as a percentage mass fraction, which is calculated as given in Formula (43):

$$w_{\text{O,S}^{2-}} = 0,5 w_{\text{S}^{2-}} \quad (43)$$

5.5.3.2 Correcting total oxide analysis for halides

5.5.3.2.1 Correcting total oxide analysis for chloride

Irrespective of whether the analysis has been carried out on a fused (bead) or pressed (pellet) test portion, calculate the factor, f_{Cl} , to correct the total analysis of cement containing chloride as given in Formula (44):

$$f_{\text{Cl}} = w_{\text{Cl}} + L_{\text{cor}} + w_{\text{O,tot}} - w_{\text{O,Cl}} \quad (44)$$

where

w_{Cl} is the chloride content, expressed as a percentage mass fraction;

$w_{\text{O,Cl}}$ is the oxygen equivalent of chloride, expressed as a percentage mass fraction, which is calculated as given in Formula (45):

$$w_{\text{O,Cl}} = 0,2 w_{\text{Cl}} \quad (45)$$

NOTE Any correction for the presence of chloride is generally very small and is usually ignored.

5.5.3.2.2 Correcting total oxide analysis for bromide

Irrespective of whether the analysis has been carried out on a fused (bead) or pressed (pellet) test portion, calculate the factor, f_{Br} , to correct the total analysis of cement containing bromide as given in Formula (46):

$$f_{\text{Br}} = w_{\text{Br}} + L_{\text{cor}} + w_{\text{O,tot}} - w_{\text{O,Br}} \quad (46)$$

where

w_{Br} is the bromide content, expressed as a percentage mass fraction;

$w_{\text{O,Br}}$ is the oxygen equivalent of bromide, expressed as a percentage mass fraction, which is calculated as given in Formula (47):

$$w_{\text{O,Br}} = 10 w_{\text{Br}} \quad (47)$$

NOTE Any correction for the presence of bromide is generally very small and is usually ignored.

5.6 Preparation of fused beads and pressed pellets

5.6.1 General

At several of the stages, a choice of procedures is given. Once a choice has been made, the procedure shall be adhered to throughout calibration and analysis, unless a new calibration is carried out in accordance with 5.7.

The bead or pellet preparation conditions shall be set such that the criteria given in 5.7.3 are met.

5.6.2 Conversion of the sample to bead form

5.6.2.1 Weighing of the sample

5.6.2.1.1 General

Weigh the sample, the flux and any anti-wetting agent to the nearest 0,000 1 g and to the ratio, R , selected. Add the anti-wetting agent, when used as a solution, using a micro-pipette. The sample being used shall be weighed as given in either 5.6.2.1.2 or 5.6.2.1.3.

5.6.2.1.2 Unignited samples

The required mass, m_3 , expressed in grams, of the unignited sample is calculated as given in Formula (48):

$$m_3 = \frac{m_4}{\left(1 - \frac{L}{100}\right)} \quad (48)$$

where

m_4 is the mass of fused sample (see 5.3.3) required to prepare a bead, expressed in grams;

L is the observed loss on ignition, expressed in percent (see 5.4.3.1).

5.6.2.1.3 Ignited samples

Prepare the sample in accordance with 5.4.2 but, in this case, the appropriate amount of the sample may be used. A constant mass is reached when the difference between two successive weighings is less than 0,05 % mass fraction. Store ignited samples in a desiccator.

When preparing a bead using the ignited sample, carry out weighings as quickly as possible to avoid contamination.

Where the sample contains significant amounts of carbonate that can result in loss of material through spurning, or where it contains carbides, iron or other metals that can interact with platinum and damage the crucible, the ignited sample should be used in the preparation of beads.

The amount of the sample should not be more than 5 g, because it is difficult with a larger sample to reach a constant mass without repeated ignitions. However, if a large amount of sample is being used, lumps in the sample should be broken up after the first ignition.

5.6.2.2 Fusion procedure

Thoroughly mix the sample, the flux and any anti-wetting agent before fusion. Where the anti-wetting agent is added as a solution, it shall be added after placing the mixture of sample and flux into the fusion vessel and evaporating all moisture at a low temperature before the fusion. Fuse the mixture for the prescribed time, e.g. 10 min, at the selected, controlled temperature with occasional swirling until the sample dissolves and the melt is homogeneous.

NOTE The volatilisation of sulfur trioxide becomes significant for samples fused at temperatures in excess of 1 100 °C. Where sulfur trioxide is being determined, it is essential to keep the temperature below this level.

The fusion temperature may be specified according to cement or element type. For more volatile elements, e.g. sulfate, sulfide, chloride or alkalis, fusion at reduced temperature or the use of pressed pellets can be necessary to achieve the required precision.

Increasing the temperature in two stages has been shown to improve precision.

5.6.3 Casting of the beads

5.6.3.1 General

Cast the beads using one of the following methods. Beads produced shall be free from blemishes on the analytical measuring surface.

- a) Outside the furnace: after 5 min, remove the casting mould (and the heat reservoir) from the furnace and place on a horizontal surface. Remove the lid from the fusion dish, remove the dish from the furnace and immediately pour the melt into the casting mould.
- b) In the furnace: after 5 min, remove the lid from the fusion dish and pour the melt into the casting mould inside the furnace, ensuring that as much of the melt is transferred to the casting mould as possible. Remove the casting mould from the furnace and place on a horizontal surface.
- c) Combined fusion mould: after 5 min, remove the fusion mould from the furnace and by swirling ensure the transfer of the whole of the melt into the mould part of the dish.
- d) Mould heated over burner: after preparation of the melt, pour the melt into the preheated casting mould and turn the burner off.
- e) Inside the fusion mould: after completion of the fusion, leave the melt inside the fusion dish and remove it from the furnace.

5.6.3.2 Cooling of the beads

Allow the casting mould to cool on a horizontal surface.

If rapid cooling is required, when the melt has cooled from red heat, transfer the casting mould to an air jet (5.2.6) (or alternatively, a water-cooled plate). The melt can be molten or solid at this stage. Hold the dish in a horizontal position above the air jet so that the air is directed onto the centre of the base of the mould. When the bead has solidified and released itself, turn off the air jet.

NOTE It can be necessary to encourage the release of the beads at this stage by gently tapping the casting mould on a solid surface.

5.6.4 Automatic bead preparation

An automatic fusion apparatus (5.2.5) may be used to prepare beads.

5.6.5 Storage

Protect beads from deterioration caused by adverse temperature and humidity conditions, e.g. by storage in a polyethylene self-seal container. If the laboratory environment is suitably controlled (e.g. air-conditioned), then the container shall be stored in a desiccator. Alternatively, if the environment is not controlled, the containers shall be stored in a temperature-controlled oven at 25 °C to 30 °C.

Where pressed pellets are being stored for a limited period, they may be placed unwrapped in a desiccator.

The containers themselves can cause surface contamination due to the use of "anti-blocking agents" (the effect being more apparent for the lighter elements). After long-term storage, thoroughly clean the measuring surfaces of beads before use, e.g. by washing with ethanol or acetone or by polishing.

NOTE Reported sources of contamination are as follows: sulfur from vacuum oil in the spectrometer or from the laboratory atmosphere; sodium and chlorine from manual contact and the atmosphere if the laboratory is near the sea; sodium and potassium from cigarette smoke.

5.6.6 Pressed pellets

Weigh, to the nearest 0,1 g, a quantity of sample suitable to fill the mould to excess. Grind to a suitable fineness, with a binding agent (5.1.4) if necessary. Place the ground sample into the pellet mould (5.2.12) and spread evenly. Apply pressure at a rate and for a time shown to be suitable to ensure that the criteria given in 5.7.3 are met. Store in accordance with 5.6.5 until required.

NOTE In automated pellet preparation, the sample is dosed volumetrically.

5.7 Calibration and validation

5.7.1 Principles

The calibration equations and inter-element corrections are established using calibration standards produced using beads or pellets made from pure reagents, CRMs, IRMs or any combination of these (see 5.1). The validity of the calibration is confirmed by analysing one or more CRMs, representative of the range of analyses being undertaken. The ongoing calibration monitoring for intensity, bead preparation and calibration drift is determined immediately after calibration and at intervals during the analytical process. Typical ranges for calibration standards for analysis of CEM I cements are given in Annex C. Examples of sources of CRMs are shown in Annex B. Performance criteria are set out in 5.9.

5.7.2 Calibration and validation samples

5.7.2.1 Calibration standards

Prepare a series of beads or pellets from pure reagents, IRMs, CRMs or combinations of these (see 5.1) as calibration standards. The series shall cover the range from the minimum to the maximum values for each element being analysed and shall be evenly distributed between those limits. The variations in the concentration of each element in the calibration standard shall be independent of each other. The minimum number of standards is seven.

An example of a series of calibration standards suitable for the analysis of cements of type CEM I, in accordance with EN 197-1, is given in Annex C. Other reagents may be added to cover the scope of the elements being determined.

Where ten standards or fewer are used, duplicate beads or pellets should be prepared. Where a larger number of standards is used, single preparation can be sufficient.

For pellet analysis, a calibration made from IRMs or CRMs can provide unsatisfactory results due to mineralogical effects. In this case, the calibration may be done with secondary standards, made from samples routinely analysed by the laboratory, that have been characterised with at least one analysis by reference methods or by X-ray fluorescence using fused beads.

5.7.2.2 Calibration validation of a CRM or IRM

Prepare one or more CRMs, not used in the calibration standard (5.7.2.1) and having a composition within the calibration range for each element being analysed.

When only one validation CRM is being used, select a sample in the middle of the concentration ranges. Where several validation CRMs are used, select samples covering high and low values.

Examples of sources of CRMs are given in Annex B.

If no suitable CRM is available, choose an IRM that satisfies the above criteria. It is recommended that each IRM be validated by at least four laboratories.

In the case of pressed pellets, and especially for composite cements, variations in mineralogy can affect the accuracy. In such cases, it is essential to use an IRM matching closely each type of sample being analysed, and preferably made from the samples routinely analysed by the laboratory.

5.7.2.3 Intensity correction samples

NOTE 1 These are sometimes referred to as “monitor” samples.

Use one or more samples, (glass beads or other stable material) each having a composition giving an intensity level similar to the calibration range for each element being analysed. If several samples are used, select high and low values for each element. These samples shall be different from the calibration standards (see 5.7.2.1). Store these samples for future reference. Excessive exposure to the X-ray beam shall be avoided to prevent ageing.

NOTE 2 Samples stored as pellets are subject to rapid ageing and, therefore, it is preferable that fused beads or glass be used for intensity control, even where the analysis predominantly uses pellet calibrations.

The samples shall be used to calculate a correction factor to apply to the raw intensity measurements, to take account of the ageing of the apparatus (X-ray tube, detectors, etc.) (see 5.7.4.3).

5.7.2.4 Re-calibration standards

Select two of the calibration standards (5.7.2.1), having high and low values for each element of interest, and store for future reference.

NOTE Depending on the equipment, it might be required to define re-calibration standards at the time of the initial calibration.

They shall be used to adjust the equation of the calibration curve in the event that the drift of the apparatus is not sufficiently corrected by the intensity correction procedure (see 5.7.4.2).

5.7.2.5 Spectrometer control samples

5.7.2.5.1 Control for bead analysis

Prepare and store one or more beads within, or close to, the calibration range. Calibration validation samples (see 5.7.2.2) are suitable.

A replacement bead may be prepared if ageing is suspected.

5.7.2.5.2 Control for pellet analysis

Due to the more rapid ageing of pellets, it is not possible to ensure control of the spectrometer using pellets. Therefore, the spectrometer control for pellet analysis shall be made using a fused bead or glass sample.

5.7.2.6 Preparation procedure control sample

Prepare a new bead or pellet of the calibration validation samples (see 5.7.2.2) as a control for the preparation procedure.

5.7.3 Initial calibration

5.7.3.1 Calibration procedure

Establish the calibration relationship between the intensity of measured X-rays and the element concentration, including corrections for any mass absorption and line overlap effects.

At a reasonable counting time (e.g. 3 min to 5 min), measure and record the intensities for each element being determined in all of the calibration beads or pellets. Using regression analysis, establish the calibration curve for each element being determined.

NOTE Increasing the counting time on the measurement of the standards can improve the accuracy of the calibration.

5.7.3.2 Calibration for inter-element effects

Where inter-element effects significantly influence the accuracy of the calibration, e.g. the influence of potassium on calcium, it can be necessary to establish a correction. For each inter-element correction applied, prepare at least one additional calibration standard bead or pellet.

5.7.3.3 Validation of calibration

Validate the accuracy of the calibration for the elements being determined by analysing, in duplicate, at least one accuracy validation sample [see 5.7.2.2 (CRM or IRM)].

When selecting a CRM or IRM for validation, it is recommended that the series of analyses used to produce the certified analysis be examined in relation to the criteria for repeatability, reproducibility and accuracy (see 5.9).

The calibration is valid if all the elements being determined satisfy the accuracy limits set down in Table 8.

If the calibration is not valid:

- a) consider the need for a calibration adjustment for inter-element effects (see 5.7.3.2);
- b) consider whether the set of standards used is adequate;
- c) determine other cause(s), and take appropriate corrective action; or,
- d) repeat initial calibration in accordance with 5.7.3, as appropriate.

5.7.3.4 Validation of repeatability

5.7.3.4.1 General

Validate the repeatability of analysis for a new spectrometer when there has been any major modification of the preparation procedure or the spectrometer.

5.7.3.4.2 Repeatability of the spectrometer

Measure, over a period of not more than one week, the same bead of the spectrometer control sample (see 5.7.2.5) at least ten times. Record the average and calculate the standard deviation of these measurements. To validate the spectrometer repeatability, the standard deviation shall be less than one-third of the repeatability limits defined in Table 7.

The limits in Table 7 allow for the overall procedure repeatability. The repeatability of the spectrometer itself should be lower, to ensure the required repeatability of the method.

If the repeatability of the spectrometer is not validated, implement one of the following and repeat the repeatability validation:

- a) check the stability of the apparatus (gas flow, temperature regulation, etc.);
- b) increase the counting time;

- c) increase the sample-to-flux ratio for the bead to improve sensitivity.

5.7.3.4.3 Repeatability of the method

Prepare and analyse, over an appropriate period of time (e.g. at least two weeks), at least ten different preparations of the preparation procedure control sample (see 5.7.2.6). Record the average and the calculated standard deviation.

The repeatability of the method is valid if the difference in results for each new preparation, compared with the previous example, is within the repeatability limits defined in Table 7.

If the repeatability of the method is not validated:

- a) check the stability of the apparatus (gas flow, temperature regulation, etc.);
- b) increase the counting time;
- c) increase the sample-to-flux ratio for the bead to improve sensitivity;
- d) increase the fineness of the sample;
- e) adjust the temperature and/or duration of the fusion for beads;
- f) consider the use of a grinding agent or binding wax for pellets;
- g) increase the duration and/or pressure on the press for pellets.

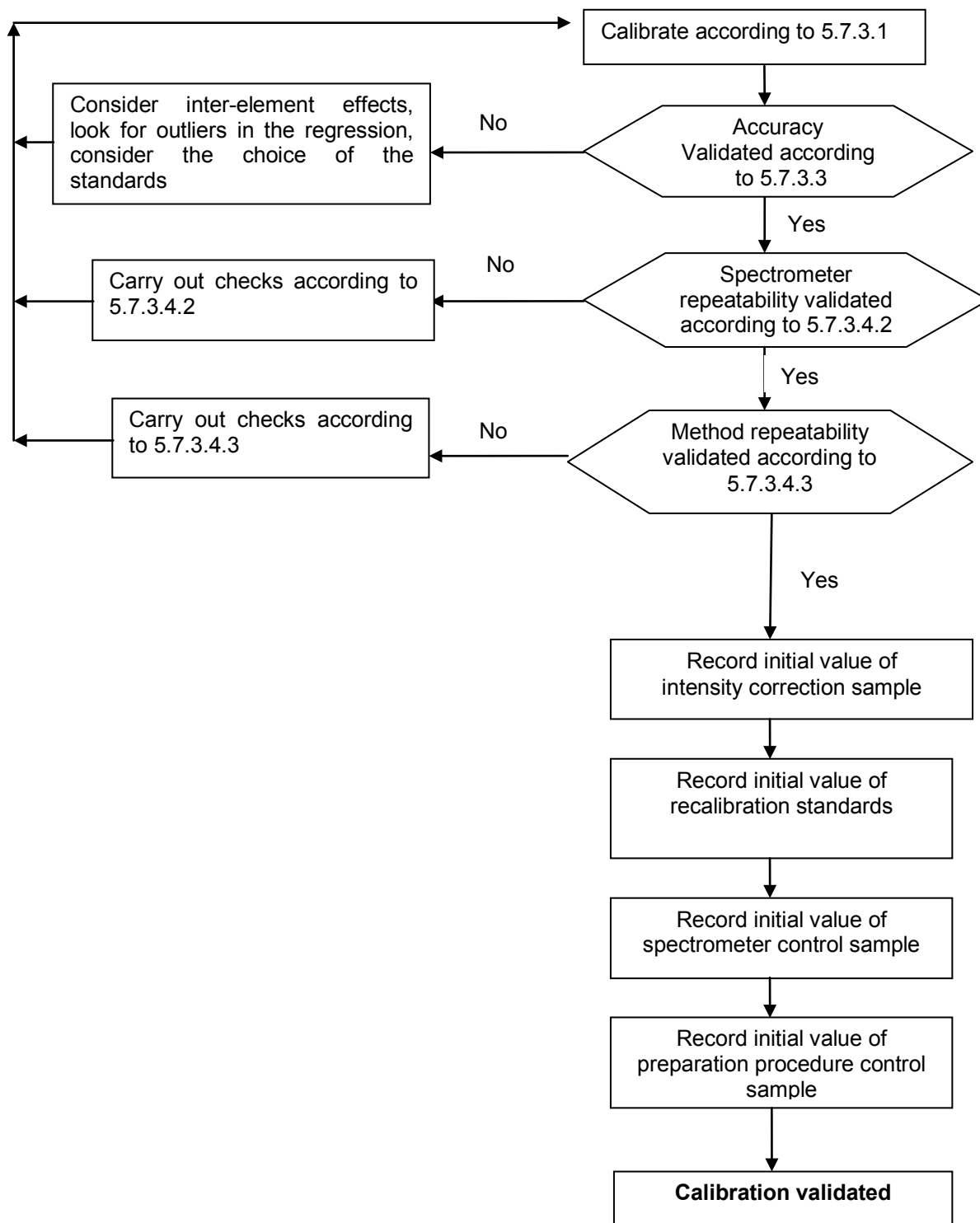

Figure 5 — Calibration validation

5.7.3.5 Initial values of the intensity correction samples

At the time of the initial calibration, record the initial values of the intensity correction samples (“monitors”; see 5.7.2.3).

NOTE It is generally possible to store these values in the software.

Store the corresponding samples for future reference.

5.7.3.6 Initial values of the re-calibration standards

At the time of the initial calibration, record the initial values of the re-calibration standards (see 5.7.2.4).

NOTE It is generally sufficient in the software to define two of the calibration standards (see 5.7.2.1) as the re-calibration standards.

5.7.3.7 Initial values of the spectrometer control sample

At the time of the initial calibration, record the average value, calculated in accordance with 5.7.3.4.2, of the spectrometer control sample (see tolerance limits in 5.7.4.2).

If ageing of the spectrometer control sample is suspected, a new bead is prepared, and new initial values are established.

5.7.3.8 Initial values of the preparation procedure control sample

At the time of the initial calibration, record the average calculated in 5.7.3.4.3 as the initial value of the preparation procedure control sample (see 5.7.2.6 and preparation repeatability validation limits in 5.7.5.1).

5.7.4 Spectrometer follow-up

5.7.4.1 Principle

5.7.4.1.1 Introduction

The main bias in X-ray fluorescence is the intensity drift due to ageing. The consistency of the results is monitored by measuring the spectrometer control sample (see 5.7.2.5), before carrying out each series of sample analyses.

In the first instance, this intensity drift is corrected using the intensity correction samples (5.7.2.3). Where this is not sufficient, correction factors may be applied to the calibration equation using the re-calibration standards. Alternatively, a full re-calibration may be necessary.

After each action that modifies the result provided by the spectrometer (e.g. drift correction or re-calibration), the accuracy shall be assessed again in accordance with 5.7.3.3.

5.7.4.1.2 General

If the spectrometer control sample is within the limits set out below, or if the calibration has been re-validated in accordance with 5.7.3.3, then the spectrometer is ready for analysis. If the analysis is not valid, apply the decision diagram in Figure 6.

5.7.4.1.3 Re-validation of bead calibration

The bead calibration remains valid if the results, compared with the initial values (see 5.7.3.7), are equal to or less than three times the standard deviation for the spectrometer determined in 5.7.3.4.2.

5.7.4.1.4 Re-validation of pellet calibration

Depending on the capabilities of the software used, record the measurements:

- a) as a corrected intensity, taking into account the intensity drift correction (see 5.7.4.2);
- b) as a concentration.

The pellet calibration remains valid if the results, compared with the initial values (see 5.7.3.7), are equal to or less than three times the standard deviation for the spectrometer determined in 5.7.3.4.2.

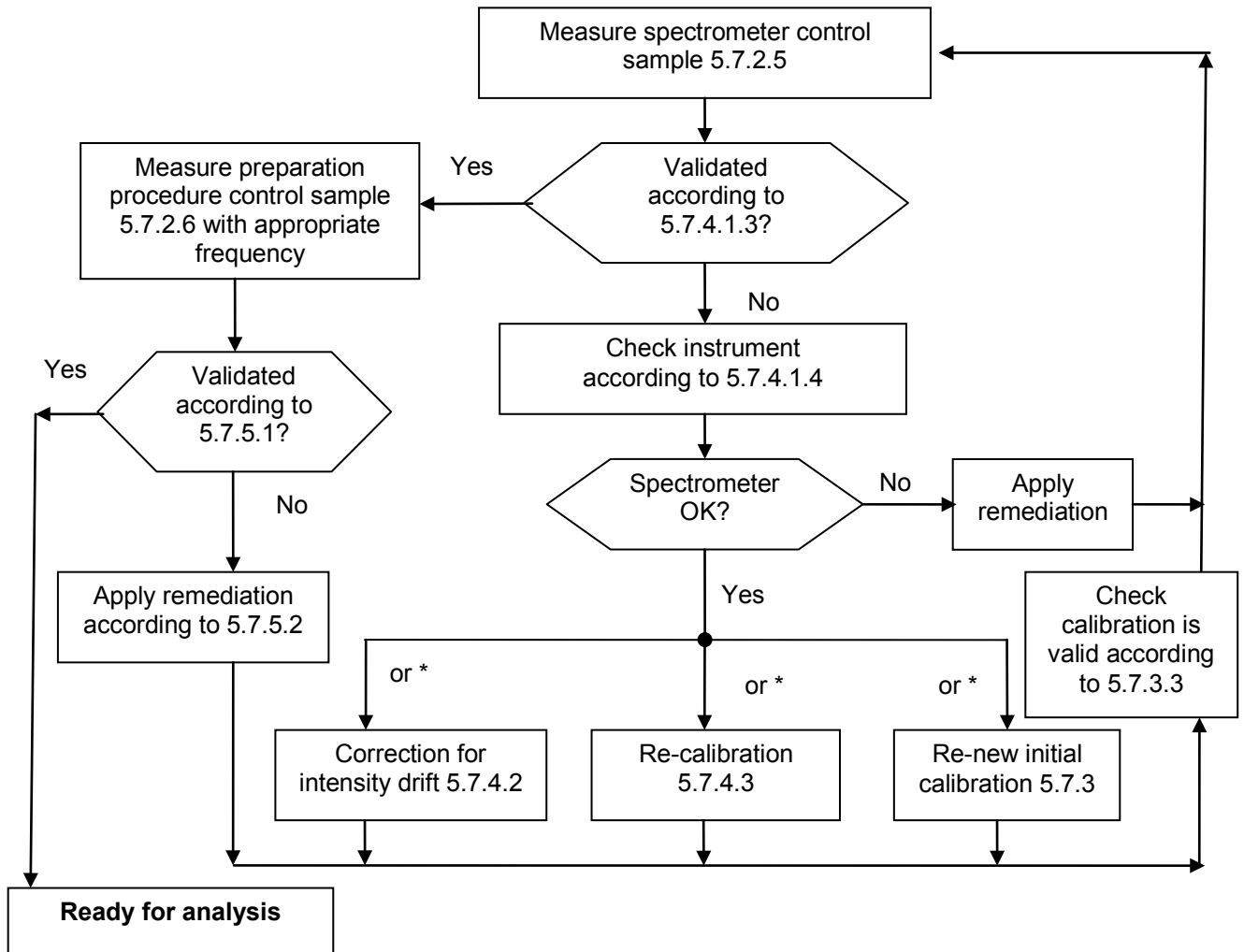

* Apply successively one or several of the proposed corrective actions. If several actions are necessary, apply in the following order:

- 1) Correction for intensity drift;
- 2) Recalibration;
- 3) Renew initial calibration.

Figure 6 — Analysis validation decision scheme — Instrument check

Carry out the following checks, as necessary, when any automatic fine adjustment, present in software on some spectrometers, has been made:

- c) gas flow;
- d) temperature regulation;
- e) counter resolution problems;

- f) 2-theta angle settings;
- g) high-voltage settings of the detector.

5.7.4.2 Correction for intensity drift

Where necessary (see Figure 6), a correction factor is calculated for each element to compensate for the drift in intensity due to ageing of the tube, detector, etc. Subsequently, the corrected intensities are then used in the calibration equation to derive the concentrations.

NOTE In most software applications, this correction is applied to all calibrations for each element.

The intensity drift should be small and regular with time. A sudden change in intensity indicates an instrumental problem, and correction by this intensity drift method is not appropriate.

5.7.4.3 Re-calibration

Where necessary (see Figure 6), if the intensity correction (see 5.7.4.2) is insufficient to achieve accurate results for the analysis validation (see 5.7.4.1), it is possible to apply correction factors to the calibration curves using the re-calibration standards.

The modifications in the calibration equation due to instrumental drift should be small and regular with time. Any rapid or major bias in the analytical results can indicate an instrumental or analytical problem, and correction by this re-calibration method is not appropriate.

5.7.5 Preparation procedure follow-up

5.7.5.1 Bead and pellet preparation validation

On a regular basis, the whole analysis method shall be checked, including preparation of the bead or pellets and the measurement on the spectrometer.

Prepare a new preparation procedure control sample (see 5.7.2.6). The preparation is valid if:

- a) the results of the new analysis, compared with the initial values (see 5.7.3.8), are within the limits for repeatability set down in Table 7;
- b) the ongoing average values for new analyses, compared with the certified values of the CRM or IRM, are within the limits for accuracy set down in Table 8.

5.7.5.2 Remedial action for preparation bias

If the analysis fails to satisfy the repeatability or accuracy limits set down in 5.7.5.1, check whether:

- a) the loss on ignition of the flux has increased;
- b) drift could have occurred due to the preparation apparatus (check temperature, fineness, quality of sample surface, etc.);
- c) a new batch of flux has been introduced;
- d) a new bead or pellet preparation apparatus has been installed;
- e) the sample preparation procedure has been changed or modified, e.g. from manual to automatic;
- f) a new type of flux or new sample-to-flux ratio has been used;
- g) other procedural or apparatus changes have been introduced.

In the first two cases, take remedial action and re-check the analysis. In all other cases, carry out a full re-calibration, including new preparation of all of the samples in accordance with 5.7.2.

Table 7 — Repeatability limits for analysis validation

Element mean value % mass fraction	Repeatability limit for “normal” performance % mass fraction absolute	Repeatability limit for “expert” performance % mass fraction absolute
0 to 0,49	0,057	0,023
0,50 to 0,99	0,080	0,032
1,00 to 1,99	0,110	0,044
2,00 to 3,99	0,135	0,054
4,00 to 4,99	0,155	0,062
5,00 to 6,99	0,172	0,069
7,00 to 9,99	0,202	0,081
10,00 to 14,99	0,240	0,096
15,00 to 19,99	0,290	0,116
20,00 to 24,99	0,335	0,134
25,00 to 29,99	0,372	0,149
30,00 to 34,99	0,405	0,162
35,00 to 39,99	0,437	0,175
40,00 to 44,99	0,465	0,186
45,00 to 49,99	0,492	0,197
50,00 to 54,99	0,517	0,207
55,00 to 59,99	0,542	0,217
60,00 to 64,99	0,565	0,226
65,00 to 69,99	0,587	0,235
70,00 to 74,99	0,610	0,244
75,00 to 79,99	0,630	0,252
80,00 to 100	0,650	0,260

NOTE All values of repeatability are expressed on the basis of fused, i.e. loss-on-ignition-free, samples.

Table 8 — Accuracy limits for validation

Content of element species % mass fraction absolute	Accuracy limit for “normal” performance % mass fraction absolute	Accuracy limit for “expert” performance % mass fraction absolute
0 to 0,49	0,05	0,02
0,50 to 0,99	0,08	0,03
1,00 to 6,99	0,20	0,08
7,00 to 14,99	0,30	0,12
15,00 to 29,99	0,38	0,15
30,00 to 49,99	0,50	0,20
50,00 to 79,99	0,63	0,25
80,00 to 100	0,75	0,30

NOTE All values of accuracy are expressed on the basis of fused, i.e. loss-on-ignition-free, samples.

Table 9 — Reproducibility limits achieved using certified reference materials

Element mean value % mass fraction	Reproducibility limit for “normal” performance % mass fraction	Reproducibility limit for “expert” performance % mass fraction
0,5	0,112	0,045
1,0	0,150	0,060
2,0	0,225	0,090
3,0	0,262	0,105
4,0	0,300	0,120
5,0	0,352	0,135
7,0	0,412	0,165
10	0,487	0,195
15	0,562	0,225
20	0,675	0,270
25	0,750	0,300
30	0,825	0,330
35	0,862	0,345
40	0,937	0,375
45	0,975	0,390
50	1,050	0,420
55	1,087	0,435
60	1,125	0,450
65	1,162	0,465
70	1,237	0,495
75	1,275	0,510
80	1,312	0,525

NOTE All values of reproducibility are expressed on the basis of fused, i.e. loss-on-ignition-free, samples.

5.8 Calculation and expression of results

Calculate the concentrations on a fused basis from the calibration curve (see 5.7.3.1), corrected, where necessary, for any inter-element effect (see 5.7.3.2).

Calculate the results, where a single test result has been obtained, as a percentage mass fraction to four significant figures when the value exceeds 1,00 % mass fraction, or to three decimal places for values below 1,00 % mass fraction.

Calculate the results, where two test results have been obtained, as the mean of the results, as a percentage mass fraction to four significant figures when the value exceeds 1,00 % mass fraction, or to three decimal places for values below 1,00 % mass fraction.

If the two test results differ by more than the appropriate repeatability limits set out in Table 7, repeat the test and take the mean of the two closest test results.

Convert test results on a fused basis to results on the as-received basis using the factor, f_{LOI} , in accordance with 5.5.2.3.

Where the sample contains oxidisable sulfur species, or any chloride or bromide, see 5.5.3 with regard to totalling the oxide analysis.

The results of all individual tests shall be recorded.

Express the results, generally as the oxide, to two decimal places.

5.9 Performance criteria (repeatability, accuracy and reproducibility limits)

Performance criteria are given in Tables 7, 8 and 9.

Annex A (informative)

Examples of fluxes

There are three examples of fluxes that have proved suitable:

- a) 66 % lithium tetraborate + 34 % lithium metaborate; purity 99,95 % (minimum);
- b) 100 % lithium tetraborate; nominal purity 100 %;
- c) lithium tetraborate/lithium metaborate, in ratios of 100/0 to 0/100 %; purity 99,98 %.

Annex B (informative)

Sources of certified reference materials

Examples of sources of certified reference materials include the following:

BCR	Community Bureau of Reference (Belgium);
BCS	British Chemical Standards (United Kingdom);
CANMET	Canada Centre for Mineral and Energy Technology (Canada);
DL	Dillinger Laboratory (Germany);
ECRM	Euronorm Certified Reference Materials (Europe);
GBW	State Bureau of Technical Supervision (China);
JSS	Iron and Steel Institute of Japan (Japan);
NCB	National Council for Cement and Building Materials (India);
NIST	National Institute of Standards and Technology (United States of America);
SARM	South African Bureau of Standards (South Africa); and
Glass beads	BREITLÄNDER Eichproben + Labormaterial GmbH (Germany) ¹⁾ .

1) This is an example of a suitable commercial supplier. This information is given for the convenience of users of EN 196-2 and does not constitute an endorsement by CEN.

Annex C (informative)

Examples of calibration standards and monitor beads and pellets

Table C.1 — Calibration standards for the calibration of analysis of CEM I cements

Reagent	Mass of reagents required for each fusion						
	g						
	Bead number						
	1	2	3	4	5	6	7
SiO ₂	0,240 0	0,195 0	0,204 0	0,223 0	0,180 0	0,187 0	0,214 0
Al ₂ O ₃	0,072 0	0,081 0	0,026 0	0,054 0	0,045 0	0,063 0	0,036 0
Fe ₂ O ₃	0,015 0	0,061 0	0,068 0	0,042 0	0,053 0	0,023 0	0,034 0
CaCO ₃	1,042 2	1,091 2	1,096 0	1,148 7	1,135 4	1,188 6	1,199 2
MgO	0,011 0	0,017 0	0,040 0	0,026 0	0,022 0	0,032 0	0,005 0
K ₂ CO ₃	0,014 7	0,005 9	0,002 9	0,011 7	0,008 8	0,017 6	—
CaSO ₄	0,068 0	0,030 6	0,045 9	0,003 4	0,057 8	0,017 0	0,039 1
Total	1,462 9	1,481 7	1,482 8	1,508 8	1,502 0	1,528 2	1,527 3

Table C.2 — Composition of the calibration standards listed in Table C.1

Oxide	Composition						
	% mass fraction						
	Bead number						
	1	2	3	4	5	6	7
SiO ₂	24,0	19,5	20,4	22,3	18,0	18,7	21,4
Al ₂ O ₃	7,2	8,1	2,6	5,4	4,5	6,3	3,6
Fe ₂ O ₃	1,5	6,1	6,8	4,2	5,3	2,3	3,4
CaO	61,2	62,4	63,3	64,5	66,0	67,3	68,8
MgO	1,1	1,7	4,0	2,6	2,2	3,2	0,5
K ₂ O	1,0	0,4	0,2	0,8	0,6	1,2	0,0
SO ₃	4,0	1,8	2,7	0,2	3,4	1,0	2,3
Total	100,0	100,0	100,0	100,0	100,0	100,0	100,0

Bibliography

- [1] ISO 5725-1, *Accuracy (trueness and precision) of measurement methods and results — Part 1: General principles and definitions*
- [2] ISO/TR 12389, *Methods of testing cement — Report of a test programme — Chemical analysis by x-ray fluorescence*

British Standards Institution (BSI)

BSI is the national body responsible for preparing British Standards and other standards-related publications, information and services.

BSI is incorporated by Royal Charter. British Standards and other standardization products are published by BSI Standards Limited.

About us

We bring together business, industry, government, consumers, innovators and others to shape their combined experience and expertise into standards-based solutions.

The knowledge embodied in our standards has been carefully assembled in a dependable format and refined through our open consultation process. Organizations of all sizes and across all sectors choose standards to help them achieve their goals.

Information on standards

We can provide you with the knowledge that your organization needs to succeed. Find out more about British Standards by visiting our website at bsigroup.com/standards or contacting our Customer Services team or Knowledge Centre.

Buying standards

You can buy and download PDF versions of BSI publications, including British and adopted European and international standards, through our website at bsigroup.com/shop, where hard copies can also be purchased.

If you need international and foreign standards from other Standards Development Organizations, hard copies can be ordered from our Customer Services team.

Subscriptions

Our range of subscription services are designed to make using standards easier for you. For further information on our subscription products go to bsigroup.com/subscriptions.

With **British Standards Online (BSOL)** you'll have instant access to over 55,000 British and adopted European and international standards from your desktop. It's available 24/7 and is refreshed daily so you'll always be up to date.

You can keep in touch with standards developments and receive substantial discounts on the purchase price of standards, both in single copy and subscription format, by becoming a **BSI Subscribing Member**.

PLUS is an updating service exclusive to BSI Subscribing Members. You will automatically receive the latest hard copy of your standards when they're revised or replaced.

To find out more about becoming a BSI Subscribing Member and the benefits of membership, please visit bsigroup.com/shop.

With a **Multi-User Network Licence (MUNL)** you are able to host standards publications on your intranet. Licences can cover as few or as many users as you wish. With updates supplied as soon as they're available, you can be sure your documentation is current. For further information, email bsmusales@bsigroup.com.

BSI Group Headquarters

389 Chiswick High Road London W4 4AL UK

Revisions

Our British Standards and other publications are updated by amendment or revision.

We continually improve the quality of our products and services to benefit your business. If you find an inaccuracy or ambiguity within a British Standard or other BSI publication please inform the Knowledge Centre.

Copyright

All the data, software and documentation set out in all British Standards and other BSI publications are the property of and copyrighted by BSI, or some person or entity that owns copyright in the information used (such as the international standardization bodies) and has formally licensed such information to BSI for commercial publication and use. Except as permitted under the Copyright, Designs and Patents Act 1988 no extract may be reproduced, stored in a retrieval system or transmitted in any form or by any means – electronic, photocopying, recording or otherwise – without prior written permission from BSI. Details and advice can be obtained from the Copyright & Licensing Department.

Useful Contacts:

Customer Services

Tel: +44 845 086 9001

Email (orders): orders@bsigroup.com

Email (enquiries): cservices@bsigroup.com

Subscriptions

Tel: +44 845 086 9001

Email: subscriptions@bsigroup.com

Knowledge Centre

Tel: +44 20 8996 7004

Email: knowledgecentre@bsigroup.com

Copyright & Licensing

Tel: +44 20 8996 7070

Email: copyright@bsigroup.com



...making excellence a habit.™