

# Personal eye-protection — Specifications

The European Standard EN 166:2001 has the status of a  
British Standard

ICS 13.340.20

## National foreword

This British Standard is the official English language version of EN 166:2001. It supersedes BS EN166:1996 which is withdrawn.

The UK participation in its preparation was entrusted by Technical Committee PH/2, Eye-protection, to Subcommittee PH/2/2, Industrial eye-protectors, which has the responsibility to:

- aid enquirers to understand the text;
- present to the responsible European committee any enquiries on the interpretation, or proposals for change, and keep the UK interests informed;
- monitor related international and European developments and promulgate them in the UK.

A list of organizations represented on this subcommittee can be obtained on request to its secretary.

### Cross-references

The British Standards which implement international or European publications referred to in this document may be found in the BSI Standards Catalogue under the section entitled "International Standards Correspondence Index", or by using the "Find" facility of the BSI Standards Electronic Catalogue.

A British Standard does not purport to include all the necessary provisions of a contract. Users of British Standards are responsible for their correct application.

**Compliance with a British Standard does not of itself confer immunity from legal obligations.**

This British Standard, having been prepared under the direction of the Health and Environment Sector Policy and Strategy Committee, was published under the authority of the Standards Policy and Strategy Committee on 28 January 2002

### Summary of pages

This document comprises a front cover, an inside front cover, the EN title page, pages 2 to 35 and a back cover.

The BSI copyright date displayed in this document indicates when the document was last issued.

### Amendments issued since publication

Amd. No.	Date	Comments

© BSI 28 January 2002

ISBN 0 580 38916 2

English version

## Personal eye-protection - Specifications

Protection individuelle de l'oeil - Spécifications

Persönlicher Augenschutz - Anforderungen

This European Standard was approved by CEN on 2 September 2001.

CEN members are bound to comply with the CEN/CENELEC Internal Regulations which stipulate the conditions for giving this European Standard the status of a national standard without any alteration. Up-to-date lists and bibliographical references concerning such national standards may be obtained on application to the Management Centre or to any CEN member.

This European Standard exists in three official versions (English, French, German). A version in any other language made by translation under the responsibility of a CEN member into its own language and notified to the Management Centre has the same status as the official versions.

CEN members are the national standards bodies of Austria, Belgium, Czech Republic, Denmark, Finland, France, Germany, Greece, Iceland, Ireland, Italy, Luxembourg, Netherlands, Norway, Portugal, Spain, Sweden, Switzerland and United Kingdom.



EUROPEAN COMMITTEE FOR STANDARDIZATION  
COMITÉ EUROPÉEN DE NORMALISATION  
EUROPÄISCHES KOMITEE FÜR NORMUNG

**Management Centre: rue de Stassart, 36 B-1050 Brussels**

## Contents

	page
Foreword.....	3
<b>1 Scope .....</b>	<b>4</b>
<b>2 Normative references .....</b>	<b>4</b>
<b>3 Terms and definitions.....</b>	<b>5</b>
<b>4 Classification.....</b>	<b>5</b>
4.1 Function of eye-protectors .....	5
4.2 Types of eye-protectors .....	5
4.3 Types of ocular.....	6
<b>5 Designation of filters .....</b>	<b>6</b>
<b>6 Design and manufacturing requirements.....</b>	<b>7</b>
6.1 General construction .....	7
6.2 Materials.....	8
6.3 Headbands.....	8
<b>7 Basic, particular and optional requirements.....</b>	<b>8</b>
7.1 Basic requirements.....	8
7.2 Particular requirements.....	14
7.3 Optional requirements.....	16
<b>8 Allocation of requirements, test schedules and application.....</b>	<b>17</b>
8.1 Requirements and test methods .....	17
8.2 Test schedules for type examination.....	17
8.3 Application of eye-protector types.....	17
<b>9 Marking .....</b>	<b>25</b>
9.1 General.....	25
9.2 Ocular marking.....	25
9.3 Frame marking .....	30
9.4 Marking of eye-protectors where the frame and ocular form a single unit .....	33
<b>10 Information supplied by the manufacturer.....</b>	<b>33</b>
<b>Annex ZA (informative) Clauses of this European Standard addressing essential requirements or other provisions of EU Directives .....</b>	<b>35</b>

## Foreword

This document has been prepared by Technical Committee CEN/TC 85, "Eye-protective equipment", the secretariat of which is held by AFNOR.

This European Standard shall be given the status of a national standard, either by publication of an identical text or by endorsement, at the latest by May 2002, and conflicting national standards shall be withdrawn at the latest by May 2002.

This European Standard replaces EN 166:1995.

This document has been prepared under a mandate given to CEN by the European Commission and the European Free Trade Association, and supports essential requirements of EU Directive(s).

For relationship with EU Directive(s), see informative annex ZA, which is an integral part of this document.

According to the CEN/CENELEC Internal Regulations, the national standards organizations of the following countries are bound to implement this European Standard: Austria, Belgium, Czech Republic, Denmark, Finland, France, Germany, Greece, Iceland, Ireland, Italy, Luxembourg, Netherlands, Norway, Portugal, Spain, Sweden, Switzerland and the United Kingdom.

## 1 Scope

This European Standard specifies functional requirements for various types of personal eye-protectors and incorporates general considerations such as:

- designation;
- classification;
- basic requirements applicable to all eye-protectors;
- various particular and optional requirements;
- allocation of requirements, testing and application;
- marking;
- information for users.

The transmittance requirements for various types of filter oculars are given in separate standards (see clause 2).

This European Standard applies to all types of personal eye-protectors used against various hazards, as encountered in industry, laboratories, educational establishments, DIY activities, etc. which are likely to damage the eye or impair vision, with the exception of nuclear radiation, X-rays, laser beams and low temperature infrared (IR) radiation emitted by low temperature sources.

The requirements of this standard do not apply to eye-protectors for which separate and complete standards exist, such as laser eye-protectors, sunglasses for general use, etc. unless such standards make specific reference to this standard.

The requirements of this standard apply to oculars for welding and allied processes but do not apply to equipment for eye and face protection for welding and allied processes, requirements for which are contained in EN 175.

Eye-protectors fitted with prescription lenses are not excluded from the field of application. The refractive power tolerances and other special characteristics dependent upon the prescription requirement are specified in EN ISO 8980-1 and EN ISO 8980-2.

## 2 Normative references

This European Standard incorporates by dated or undated reference, provisions from other publications. These normative references are cited at the appropriate places in the text, and the publications are listed hereafter. For dated references, subsequent amendments to or revisions of any of these publications apply to this European Standard only when incorporated in it by amendment or revision. For undated references the latest edition of the publication referred to applies (including amendments).

EN 165, *Personal eye-protection — Vocabulary.*

EN 167:2001, *Personal eye-protection — Optical test methods.*

EN 168:2001, *Personal eye-protection — Non-optical test methods.*

EN 169, *Personal eye-protection — Filters for welding and related techniques — Transmittance requirements and recommended utilisation.*

EN 170, *Personal eye-protection — Ultraviolet filters — Transmittance requirements and recommended use.*

EN 171, *Personal eye-protection — Infrared filters — Transmittance requirements and recommended use.*

EN 172, *Personal eye-protection — Sunglare filters for industrial use.*

EN 175, *Personal protection — Equipment for eye and face protection during welding and allied processes.*

EN 379, *Specification for welding filters with switchable luminous transmittance and welding filters with dual luminous transmittance.*

EN ISO 8980-1, *Ophthalmic optics — Uncut finished spectacle lenses - Part 1: Specifications for single-vision and multifocal lenses (ISO 8980-1:1996).*

EN ISO 8980-2, *Ophthalmic optics — Uncut finished spectacle lenses - Part 2: Specifications for progressive power lenses (ISO 8980-2:1996).*

EN ISO 8980-3, *Ophthalmic optics — Uncut finished spectacle lenses — Part 3: Transmittance specifications and test methods (ISO 8980-3:1999).*

### 3 Terms and definitions

For the purpose of this European Standard, the terms and definitions given in EN 165 and the following apply.

#### 3.1

##### **visual centre**

the point on the ocular corresponding to the intersection of the horizontal and vertical planes through the pupil of the appropriate head-form specified in clause 17 of EN 168:2001 when the eye-protector is fitted to it in accordance with the manufacturers instructions

### 4 Classification

#### 4.1 Function of eye-protectors

The function of eye-protectors is to provide protection against:

- impacts of different severities;
- optical radiations;
- molten metals and hot solids;
- droplets and splashes;
- dust;
- gases;
- short circuit electric arc;

or any combination of these.

#### 4.2 Types of eye-protectors

NOTE Refer to definitions given in EN 165.

##### 4.2.1 Spectacles with or without lateral protection

##### 4.2.2 Goggles

##### 4.2.3 Face-shields

NOTE Face-shields normally incorporate a suitable headband, browguard, helmet, protective hood or other appropriate mounting device.

## EN 166:2001 (E)

### 4.3 Types of ocular

#### 4.3.1 Mineral oculars (glass)

##### 4.3.1.1 Untoughened mineral oculars

**4.3.1.2 Toughened mineral oculars**, toughened chemically, thermally or by other processes to give superior resistance to impact in comparison with untoughened mineral oculars.

#### 4.3.2 Organic oculars (plastic)

#### 4.3.3 Laminated oculars

Oculars made in multiple layers joined together by a binder.

**NOTE** All types of oculars may be further classified into filtering types (for example according to EN 169, EN 170, EN 171, EN 172 and EN 379). They may also be classified as oculars with corrective effect and oculars without corrective effect. They may also have coatings on their surface(s) to give additional characteristics.

## 5 Designation of filters

The transmittance characteristics of a filter are represented by a scale number.

The scale number is a combination of the code number and the shade number of the filter, joined together by a dash.

The scale number for welding filters does not include a code number, it comprises the shade number only.

Table 1 gives the designation of the various types of filters specified in this European Standard.



Table 1 — Scale numbers for filters

Welding filters	Ultraviolet filters		Infrared filters	Filters for sunglare	
	No number code	Code number 2	Code number 3	Code number 4	Code number 5
<b>Scale number</b>					
1,2	2 – 1,2	3 – 1,2	4 – 1,2	5 – 1,1	6 – 1,1
1,4	2 – 1,4	3 – 1,4	4 – 1,4	5 – 1,4	6 – 1,4
1,7		3 – 1,7	4 – 1,7	5 – 1,7	6 – 1,7
2		3 – 2	4 – 2	5 – 2	6 – 2
2,5		3 – 2,5	4 – 2,5	5 – 2,5	6 – 2,5
3		3 – 3	4 – 3	5 – 3,1	6 – 3,1
4		3 – 4	4 – 4	5 – 4,1	6 – 4,1
4a					
5		3 - 5	4 - 5		
5a					
6			4 - 6		
6a					
7			4 - 7		
7a					
8			4 - 8		
9			4 - 9		
10			4 - 10		
11					
12					
13					
14					
15					
16					
<p>NOTE Code number key :</p> <p>2 Ultraviolet filter, colour recognition may be affected ;</p> <p>3 Ultraviolet filter, good colour recognition ;</p> <p>4 Infra-red filter ;</p> <p>5 Sunglare filter without infrared specification ;</p> <p>6 Sunglare filter with infrared specification.</p>					

## 6 Design and manufacturing requirements

### 6.1 General construction

Eye-protectors shall be free from projections, sharp edges or other defects which are likely to cause discomfort or injury during use.

## 6.2 Materials

No parts of the eye-protector which are in contact with the wearer shall be made of materials which are known to cause any skin irritation.

## 6.3 Headbands

Headbands, when used as the principal means of retention, shall be at least 10 mm wide over any portion which may come into contact with the wearer's head. Headbands shall be adjustable or self-adjusting.

## 7 Basic, particular and optional requirements

All eye-protectors shall meet the basic requirements given in 7.1.

Furthermore, according to their intended use, eye-protectors shall, if appropriate, meet one or more of the particular requirements given in 7.2.

Optional requirements related to additional properties of eye-protectors are given in 7.3.

### 7.1 Basic requirements

#### 7.1.1 Field of vision

The size of the field of vision is defined in conjunction with the appropriate head-form described in clause 17 of EN 168:2001.

Eye-protectors shall exhibit a minimum field of vision defined by the two ellipses in Figure 1 when placed and centered at a distance of 25 mm from the surface of the eyes of the appropriate head-form. The horizontal axis shall be parallel to and 0,7 mm below the height of the line connecting the centres of the two eyes.

The horizontal length of the ellipses shall be of 22,0 mm, the vertical width of the ellipses shall be 20,0 mm. The centre distance of the two ellipses shall be  $d = c + 6$  mm, where  $c$  is the pupillary distance. The pupillary distance is 64 mm for the medium head-form and 54 mm for the small head-form, if not specified differently by the manufacture.

The test shall be carried out in accordance with clause 18 of EN 168:2001.

Dimensions in millimetres

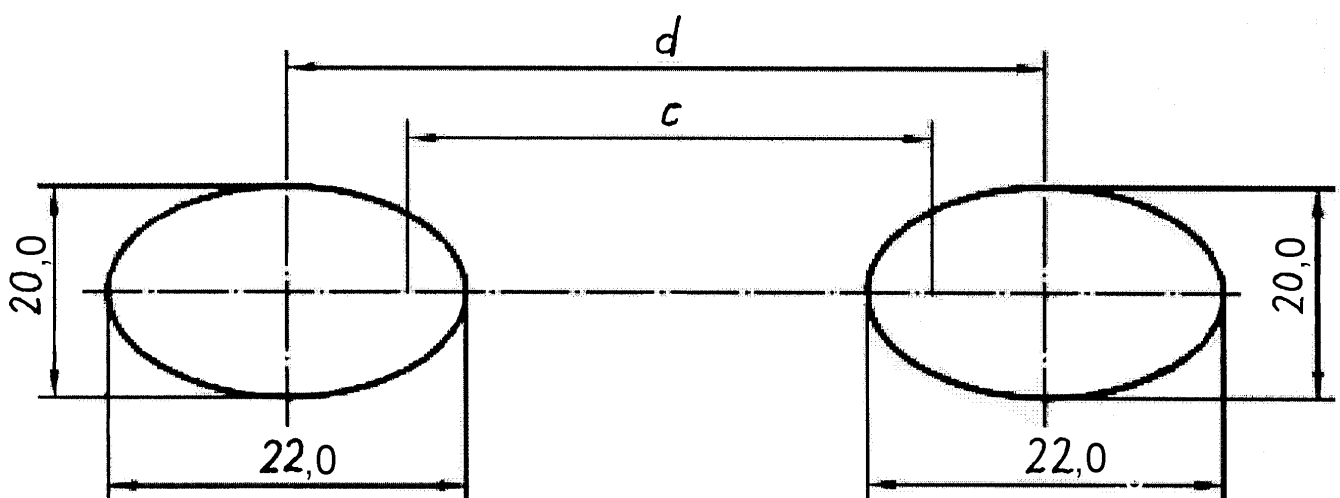

Figure 1 — Definition of the field of vision

## 7.1.2 Optical requirements

### 7.1.2.1 Spherical, astigmatic and prismatic refractive powers

The refractive powers of oculars shall be measured by the reference methods specified in clause 3 of EN 167:2001. This clause refers also to an optional method for use in specific circumstances; the details of this method are given in annex A of EN 167:2001.

#### 7.1.2.1.1 Unmounted oculars covering one eye

The refractive power characteristics of unmounted oculars covering one eye shall be measured by the method specified in 3.1 of EN 167:2001 (non-corrective oculars), and by the methods specified in EN ISO 8980-3 (corrective oculars).

The permissible tolerances for oculars without corrective effect are given in Table 2.

The permissible deviations for the vertex powers of oculars with corrective effect are specified in EN ISO 8980-1 and EN ISO 8980-2. Oculars that comply with EN ISO 8980-1 and EN ISO 8980-2 shall be categorised as class 1. For class 2, the deviations in vertex refractions may be  $0,06 \text{ m}^{-1}$  higher than for class 1.

**Table 2 — Permissible tolerances for refractive powers of unmounted oculars without corrective effect covering one eye**

Optical class	Spherical refractive power $(D_1 + D_2)/2$ $\text{m}^{-1}$	Astigmatic refractive power $ D_1 - D_2 $ $\text{m}^{-1}$	Prismatic refractive power cm/m
1	$\pm 0,06$	0,06	0,12
2	$\pm 0,12$	0,12	0,12

NOTE  $D_1$  and  $D_2$  are the refractive powers in the two principal meridians.

#### 7.1.2.1.2 Mounted oculars and unmounted oculars covering both eyes

The refractive power characteristics of mounted oculars or unmounted oculars covering both eyes shall be measured by the method specified in 3.2 of EN 167:2001 at the visual centre of the ocular.

The permissible tolerances for oculars without corrective effect are given in Table 3.

The permissible deviations for vertex powers of oculars with corrective effect are as defined in 7.1.2.1.1. Deviations that would correspond to class 3 shall not be permitted.

NOTE The difference in prismatic refractive power specified for an eye-protector depends not only on the prismatic refractive power of each ocular, but also on the position of the optical axis of the ocular in relation to the axis of vision, and therefore the shape of the frame. It is therefore necessary to use replacement oculars for which the difference in prismatic power remains within the permissible tolerance limits for the frame in question.

**Table 3 — Permissible tolerances for refractive powers of mounted oculars without corrective effect and unmounted oculars without corrective effect covering both eyes**

Optical class	Spherical refractive power $(D_1 + D_2)/2$ $m^{-1}$	Astigmatic refractive power $ D_1 - D_2 $ $m^{-1}$	Difference in prismatic refractive power  cm/m		
			Horizontal		Vertical
			Base out	Base in	
1	$\pm 0,06$	0,06	0,75	0,25	0,25
2	$\pm 0,12$	0,12	1,00	0,25	0,25
3	+ 0,12 - 0,25	0,25	1,00	0,25	0,25

NOTE  $D_1$  and  $D_2$  are the refractive powers in the two principal meridians. For optical class 3 the axes of the principal meridians shall be parallel within  $\pm 10^\circ$ .

**7.1.2.1.3 Cover plates**

The refractive powers of cover plates shall comply with the tolerances for optical class 1 given in Tables 2 and 3.

**7.1.2.2 Transmittance**

**7.1.2.2.1 Oculars without filtering action**

Oculars intended to protect the eyes against mechanical or chemical hazards only, and cover plates, shall have a luminous transmittance greater than 74,4 % when measured as given in clause 6 of EN 167:2001 (based on CIE source A (2856 K)).

**7.1.2.2.2 Oculars with filtering action (filters) and housings for oculars with filtering action.**

The transmittance of oculars with filtering action shall meet the requirements given in the specific standards relating to the various types of ocular (see 7.2.1).

Goggles and face-shields which claim to provide protection against optical radiation shall provide at least the same level of protection against optical radiation as given by a filter of any scale number declared usable with the eye-protector by the manufacturer or supplier. Testing shall be in accordance with clause 6 of EN 167:2001.

**7.1.2.2.3 Variations in transmittance (Oculars without filtering action are exempt from this requirement)**

**7.1.2.2.3.1 Oculars without corrective effect**

Variations in luminous transmittance shall be measured in accordance with clause 7 of EN 167:2001.

The relative variations of the luminous transmittance around the visual centre(s)  $P_1$  (and  $P_2$ ) shall not exceed the values of Table 4.

The relative difference in luminous transmittance  $P_3$  between left and right eye shall not exceed the values of Table 4 or 20 % whichever is greater.

Table 4 — Variations in luminous transmittance

Luminous transmittance		Permissible relative variation %
less than %	up to %	
100	17,8	± 5
17,8	0,44	± 10
0,44	0,023	± 15
0,023	0,0012	± 20
0,0012	0,000023	± 30

#### 7.1.2.2.3.2 Oculars with corrective effect (prescription oculars)

The requirements of 7.1.2.2.3.1 shall also apply to prescription oculars, with the provision that variations in luminous transmittance which are due to thickness variations inherent in the design of the ocular are not taken into account, providing the luminous transmittance at no point deviates by more than a factor of 2,68 (one shade number) from its value at the visual centre.

The IR and UV transmittance shall meet the requirements of the specified shade number at every point on the ocular.

#### 7.1.2.3 Diffusion of light

The diffusion of light shall be measured in accordance with one of the reference methods specified in clause 4 of EN 167:2001.

The maximum value of the reduced luminance factor shall be:

$$1,00 \frac{\text{cd}}{\text{m}^2 \cdot \text{lx}} \quad \text{for welding filters;}$$

$$0,75 \frac{\text{cd}}{\text{m}^2 \cdot \text{lx}} \quad \text{for oculars used in eye-protectors against high speed particles;}$$

$$0,50 \frac{\text{cd}}{\text{m}^2 \cdot \text{lx}} \quad \text{for all other oculars.}$$

#### 7.1.3 Quality of material and surface

Except for a marginal area 5 mm wide, oculars shall be free from any significant defects likely to impair vision in use, such as bubbles, scratches, inclusions, dull spots, pitting, mould marks, scouring, grains, pocking, scaling and undulation.

The assessment shall be carried out in accordance with the method specified in clause 5 of EN 167:2001.

#### 7.1.4 Robustness

##### 7.1.4.1 Minimum robustness

This requirement relates only to cover plates and oculars with filtering effect and need not be assessed if these items are intended to meet the requirements for increased robustness or resistance to high speed particles, in which case the requirements of 7.1.4.2 or 7.2.2 shall be met.

The requirement for minimum robustness is satisfied if the ocular withstands the application of a 22 mm nominal diameter steel ball with a force of  $(100 \pm 2)$  N, when tested in accordance with clause 4 of EN 168:2001.

## EN 166:2001 (E)

On so testing the following defects shall not occur:

- a) ocular fracture : an ocular shall be considered to have fractured if it cracks through its entire thickness into two or more pieces, or if more than 5 mg of the ocular material becomes detached from the surface away from the one in contact with the ball, or if the ball passes through the ocular;
- b) ocular deformation : an ocular shall be considered to have been deformed if a mark appears on the white paper on the opposite side to the one on which the force is applied.

### 7.1.4.2 Increased robustness

#### 7.1.4.2.1 Unmounted oculars

The oculars shall withstand the impact of a 22 mm nominal diameter steel ball, of 43 g minimum mass, striking the ocular at a speed of approximately 5,1 m/s, when tested in accordance with 3.1 of EN 168:2001.

On so testing the following defects shall not occur:

- a) ocular fracture : an ocular shall be considered to have fractured if it cracks through its entire thickness into two or more pieces, or if more than 5 mg of the ocular material becomes detached from the surface away from the one struck by the ball, or if the ball passes through the ocular;
- b) ocular deformation : an ocular shall be considered to have been deformed if a mark appears on the white paper on the opposite side to that struck by the ball.

#### 7.1.4.2.2 Complete eye-protectors and frames

The complete eye-protector or frame shall withstand the lateral and frontal impacts of a steel ball striking at a specified speed.

The diameter of the steel ball and the corresponding impact speed are given in Table 5.

**Table 5 — Requirements relating to increased robustness of complete eye-protectors**

Size, mass and speed of steel ball	Spectacles		Goggles		Face-shields
	Frontal impact	Lateral impact	Frontal impact	Lateral impact	
22 mm nominal diameter steel ball, of 43 g minimum mass, at a speed of approximately 5,1 m/s	√	√	√	√	√

The test shall be in accordance with the method specified in 3.2 of EN 168:2001.

If a spectacle is claimed to have lateral protection it shall not be possible for the ball to strike the lateral impact points without first striking the lateral protection.

On so testing the following defects shall not occur:

- a) ocular fracture : an ocular shall be considered to have fractured if it cracks through its entire thickness into two or more pieces, or if more than 5 mg of the ocular material becomes detached from the surface away from the one struck by the ball, or if the ball passes through the ocular;
- b) ocular deformation : an ocular shall be considered to have been deformed if a mark appears on the white paper on the opposite side to that struck by the ball;
- c) ocular housing or frame fracture : an ocular housing or frame shall be considered to have failed if it separates into two or more pieces, or if it is no longer capable of holding an ocular in position, or if an unbroken ocular detaches from the frame, or if the ball passes through the housing or frame;

- d) lateral protection failure : the lateral protection shall be considered to have failed if it fractures through its entire thickness into two or more separate pieces, or if one or more particles become detached from the surface remote from the impact point, or if it allows the ball to penetrate completely, or if it partially or totally detaches from the eye-protector, or if its component parts become separated.

### 7.1.5 Resistance to ageing

NOTE Cover plates and glass oculars are exempt from these tests. The exemption does not apply to coated or laminated glass.

#### 7.1.5.1 Stability at an elevated temperature

Assembled eye-protectors shall show no apparent deformation when tested by the method specified in clause 5 of EN 168:2001.

#### 7.1.5.2 Resistance to ultraviolet radiation (oculars only)

Oculars shall be subjected to the test for resistance to ultraviolet radiation in accordance with the method specified in clause 6 of EN 168:2001.

At the end of the test, oculars shall meet the following requirements.

- a) The relative change of luminous transmittance shall not be greater than the values specified in Table 6.

If for welding filters the relative change of the luminous transmittance is larger than the values specified in Table 6 but the actual value of luminous transmittance remains within the range specified by its shade number, a second irradiation is performed in accordance with clause 6 of EN 168:2001 on the same sample. The relative change of luminous transmittance due to the second irradiation shall not be greater than the values specified in Table 6 and the actual value of luminous transmittance shall remain within the range specified by its shade number;

- b) The value of the reduced luminance factor shall not exceed the permissible limits given in 7.1.2.3.

**Table 6 — Permissible relative change in luminous transmittance following the ultraviolet radiation test**

Luminous transmittance		Permissible relative change
less than	up to	
%	%	%
100	17,8	± 5
17,8	0,44	± 10
0,44	0,023	± 15
0,023	0,0012	± 20
0,0012	0,000023	± 30

#### 7.1.6 Resistance to corrosion

After having undergone the test for resistance to corrosion specified in clause 8 of EN 168:2001, all metal parts of the eye-protector shall display smooth surfaces, free from corrosion, when they are examined by a trained observer.

#### 7.1.7 Resistance to ignition

Eye-protectors shall be tested in accordance with the method specified in clause 7 of EN 168:2001 and shall be considered to be satisfactory if no part of the eye-protector ignites or continues to glow after removal of the steel rod.

7.2 Particular requirements

7.2.1 Protection against optical radiation

7.2.1.1 Welding filters – see EN 169.

7.2.1.2 Ultraviolet filters – see EN 170.

7.2.1.3 Infrared filters – see EN 171.

7.2.1.4 Sunglare filters for industrial use – see EN 172.

7.2.1.5 Welding Filters with switchable luminous transmittance - see EN 379.

7.2.2 Protection against high-speed particles

Eye-protectors intended to provide protection against high-speed particles shall withstand the impact of a 6 mm nominal diameter steel ball of 0,86 g minimum mass, striking the oculars and the lateral protection at one of the speeds given in Table 7.

Eye-protectors for protection against high-speed particles shall also meet the requirements for increased robustness given in 7.1.4.2.

Table 7 — Requirements relating to protection against high-speed particles

Type of eye-protector	Impact speed of ball		
	Low energy impact (F) 45 <sup>+1,5</sup> <sub>-0</sub> m/s	Medium energy impact (B) 120 <sup>+3</sup> <sub>-0</sub> m/s	High energy impact(A) 190 <sup>+5</sup> <sub>-0</sub> m/s
Spectacles	+	Not applicable	Not applicable
Goggles	+	+	Not applicable
Face-shields	+	+	+

The test shall be in accordance with the method specified in clause 9 of EN 168:2001.

It shall not be possible for the ball to strike the lateral impact point without first striking the lateral protection.

On so testing the following defects shall not occur:

- a) ocular fracture : an ocular shall be considered to have fractured if it cracks through its entire thickness into two or more pieces, or if more than 5 mg of the ocular material becomes detached from the surface away from the one struck by the ball, or if the ball passes through the ocular;
- b) ocular deformation : an ocular shall be considered to have been deformed if a mark appears on the white paper on the opposite side to that struck by the ball;
- c) ocular housing or frame failure : an ocular housing or frame shall be considered to have failed if it separates into two or more pieces, or if it is no longer capable of holding an ocular in position, or if an unbroken ocular detaches from the frame, or if the ball passes through the housing or frame;
- d) lateral protection failure : the lateral protection shall be considered to have failed if it fractures through its entire thickness into two or more separate pieces, or if one or more particles becomes detached from the surface remote from the impact point, or if it allows the ball to penetrate completely, or if it partially or totally detaches from the eye-protector, or if its component parts become separated.

NOTE Eye-protectors offering protection against high-speed particles must provide lateral protection (see 7.2.8).



### 7.2.3 Protection against molten metals and hot solids

Eye-protectors intended to provide protection against molten metals and hot solids shall be considered to be satisfactory if:

- a) the eye-protector is either a goggle or a face-shield;
- b) the viewing area of oculars for face-shields has a minimum vertical centre-line depth of 150 mm when mounted in the appropriate housing;
- c) face-shields cover the eye-region rectangle of the appropriate head-form as assessed in accordance with 10.2 of EN 168:2001;
- d) the eye-protector satisfies the requirements for one of the three impact energy categories given in 7.2.2;
- e) when tested and assessed in accordance with 10.1 of EN 168:2001 they prevent the adherence of molten metal to the portion of the eye-protector which affords protection to the eye-region rectangle ABCD shown in Figure 11 of EN 168:2001;
- f) complete penetration of oculars for goggles, and all types of frames, housings, browguards, etc. does not occur within 7 s when tested as described in clause 11 of EN 168:2001;
- g) complete penetration of oculars for face-shields does not occur within 5 s when tested as described in clause 11 of EN 168:2001.

### 7.2.4 Protection against droplets and splashes of liquids

Eye-protectors for use against droplets (goggles) and splashes of liquids (face-shields) shall be tested in accordance with the methods specified in clause 12 of EN 168:2001. The results shall be considered to be satisfactory if:

- a) no pink or crimson colouration appears in the ocular regions defined by the two circles when assessing goggles for protection against droplets. No account shall be taken of any such colouration up to a distance of 6 mm inside the edges of the eye-protector;
- b) face-shields cover the eye-region rectangle of the appropriate head-form as described in 10.2.2.2 of EN 168:2001 as assessed in accordance with 10.2 of EN 168:2001.

Additionally, face-shields for protection against splashes of liquids shall have a viewing area with a minimum vertical centre-line depth of 150 mm when mounted in the appropriate housing.

### 7.2.5 Protection against large dust particles

Eye-protectors for use against large dust particles shall be tested in accordance with the method specified in clause 13 of EN 168:2001. The result shall be considered to be satisfactory if the reflectance after the test is not less than 80 % of its value before the test.

### 7.2.6 Protection against gases and fine dust particles

Eye-protectors for use against gases and fine dust particles shall be tested in accordance with the method specified in clause 14 of EN 168:2001. They shall be regarded as satisfactory if no pink or crimson coloration appears in the area covered by the eye-protector. No account shall be taken of any such coloration up to a distance of 6 mm inside the edges of the eye-protector.

### 7.2.7 Protection against short circuit electric arc

Eye-protectors for protection against short circuit electric arc shall be face-shields only. They shall have no exposed metal parts and all external edges of the protector shall be radiussed, chamfered or otherwise treated to eliminate sharp edges.

Oculars shall have a minimum thickness of 1,4 mm and a scale number of 2-1,2 or 3-1,2.

## EN 166:2001 (E)

Face-shields shall satisfy the requirements for area of coverage defined in clause 6.2.4 (b) and shall have a viewing area with a minimum vertical centre line depth of 150 mm when mounted in the appropriate housing.

NOTE The specification of a minimum ocular thickness of 1,4 mm was derived from a series of tests in Germany on a range of materials, including polycarbonate, cellulose acetate and cellulose propionate. The distance of the material under test from the electric arc was a nominal 300 mm and the arc conditions were as follows :

Current	=	12 kA max. ;
Voltage	=	380 – 400 V ;
Frequency	=	50 Hz nominal ;
Duration	=	1 s max.

### 7.2.8 Lateral Protection

Eye-protectors claimed to provide lateral protection shall pass the lateral region coverage assessment detailed in clause 19 of EN 168:2001.

## 7.3 Optional requirements

Optional requirements are specified for additional characteristics of eye-protectors which may be found to be beneficial to the user for operational reasons.

### 7.3.1 Resistance to surface damage by fine particles

If oculars are described as resistant to surface damage by fine particles they shall have a reduced luminance factor of not more than  $5 \frac{\text{cd}}{\text{m}^2 \cdot \text{lx}}$  following the test specified in clause 15 of EN 168:2001.

NOTE This procedure does not assess resistance to abrasion.

### 7.3.2 Resistance to fogging of oculars

If oculars are described as resistant to fogging they shall remain free from fogging for a minimum of 8 s when tested in accordance with clause 16 of EN 168:2001.

NOTE This procedure does not assess resistance to fogging of the complete eye-protector.

### 7.3.3 Oculars with enhanced reflectance in the infrared

Oculars which are claimed to have enhanced reflectance in the infrared shall have a mean spectral reflectance greater than 60 % within the wavelength range 780 nm to 2 000 nm when measured in accordance with clause 8 of EN 167:2001.

### 7.3.4 Protection against high speed particles at extremes of temperature

Eye-protectors intended to provide protection against high-speed particles at extremes of temperature shall withstand the impact of a 6 mm nominal diameter steel ball of 0,86 g minimum mass, striking the oculars and the lateral protection at one of the speeds given in Table 7. The impacts are carried out after the eye-protectors have been conditioned at extremes of temperature ((55 ± 2) °C and (-5 ± 2) °C) using the method specified in clause 9 of EN 168:2001.

It shall not be possible for the ball to strike the lateral impact point without first striking the lateral protection.

On so testing the following defects shall not occur:

- a) ocular fracture : an ocular shall be considered to have fractured if it cracks through its entire thickness into two or more pieces, or if more than 5 mg of the ocular material becomes detached from the surface away from the one struck by the ball, or if the ball passes through the ocular;
- b) ocular deformation : an ocular shall be considered to have been deformed if a mark appears on the white paper on the opposite side to that struck by the ball;
- c) ocular housing or frame failure : an ocular housing or frame shall be considered to have failed if it separates into two or more pieces, or if it is no longer capable of holding an ocular in position, or if an unbroken ocular detaches from the frame, or if the ball passes through the housing or frame;
- d) lateral protection failure : the lateral protection shall be considered to have failed if it fractures through its entire thickness into two or more separate pieces, or if one or more particles becomes detached from the surface remote from the impact point, or if it allows the ball to penetrate completely, or if it partially or totally detaches from the eye-protector, or if its component parts become separated.

NOTE Eye-protectors offering protection against high speed particles at extremes of temperature must provide lateral protection (see 7.2.8).

## 8 Allocation of requirements, test schedules and application

### 8.1 Requirements and test methods

The requirements and test methods for oculars and complete eye-protectors are specified in various European Standards (see clause 2). It is the object of this clause to allocate the individual requirements and test methods to the different types of eye-protector.

Table 8 specifies those requirements and tests which apply to oculars.

Table 9 specifies those requirements and tests which apply to frames and complete eye-protectors.

### 8.2 Test schedules for type examination

The necessary number of samples for type examination and the required order of the individual tests to be carried out are shown in Table 10 (mounted and unmounted oculars) and Table 11 (frames and complete eye-protectors).

### 8.3 Application of eye-protector types

The application of eye-protector types to the various fields of use is shown in Table 12.

Table 8 — Allocation of requirements and tests for unmounted and mounted oculars

Requirement	Type of ocular								Testing		
	according to	EN	Clause	Ocular without filtering effect	Welding filters	Ultraviolet filters	Infrared filters	Sunglare filters for industrial use			Cover plates against welding splashes
									EN	Clause	
									EN	Clause	
Field of vision	166	7.1.1	+	+	+	+	+	+	168	18	
Refractive powers	166	7.1.2.1	+	+	+	+	+	+	167	3.1 and 3.2	
Transmittance	166	7.1.2.2.1	+					+	167	6	
	169	4		+					167	6	
	170	4			+				167	6	
	171	4				+			167	6	
	172	4.1					+		167	6	
	379	4.3.2/4.4.2		+					167	6	
Variation in transmittance	166	7.1.2.2.3		+	+	+	+		167	7	
Diffusion of light	166	7.1.2.3	+	+	+	+	+	+	167	4	
Quality of material and surface	166	7.1.3	+	+	+	+	+	+	167	5	
Minimum robustness <sup>a</sup>	166	7.1.4.1		+	+	+	+	+	167	4	
Increased robustness <sup>a</sup>	166	7.1.4.2.1	+	X	X	X	X	X	168	3.1	
Temperature stability	166	7.1.5.1	+	+	+	+	+		168	5	
UV-stability	166	7.1.5.2	+	+	+	+	+		168	6	
Ignition	166	7.1.7	+	+	+	+	+	+	168	7	
High speed particles	166	7.2.2	X	X	X	X	X	X	168	9	
Molten metals and hot solids	166	7.2.3	X	X	X	X	X	X	168	10 and 11	
Short circuit electric arc	166	7.2.7			+				Measurement and inspection		
Surface damage by fine particles	166	7.3.1	X	X	X	X	X	X	168	15	
Fogging	166	7.3.2	X	X	X	X	X	X	168	16	
High speed particles at extremes of temperature	166	7.3.4	X	X	X	X	X	X	168	9	
Marking	166	9.2	+	+	+	+	+	+	Visual inspection		
Ocular reflectance	166	7.3.3	X	X	X	X	X	X	167	8	
Key + Requirement is specified Empty field Requirement is not specified X Optional requirement											
<sup>a</sup> If the requirement for increased robustness is met the requirement for minimum robustness need not be assessed.											

Table 9 — Allocation of requirements and tests for frames and complete eye protectors

Requirement	Field of use and symbol								Testing	
	NONE	3	4	5	8	9	according to			
	Basic use	Droplets and splashes of liquids	Large dust particles	Gas and fine dust particles	Short circuit electric arc	Molten metals and hot solids				
							EN	Clause		
Construction and materials	166	6.1 and 6.2	+	+	+	+	+	+	By visual inspection and manufacturer's certificates	
Headband	166	6.3	+	+	+	+	+	+	By measuring	
Field of vision	166	7.1.1	+	+	+	+	+	+	168	18
Transmittance <sup>a</sup>	166	7.1.2.2.2	a	a	a	a	a	a	167	6
Increased robustness <sup>b</sup>	166	7.1.4.2.2	+	+	+	+	+	+	168	3.2
Temperature stability	166	7.1.5.1	+	+	+	+	+	+	168	5
Corrosion	166	7.1.6	+	+	+	+	+	+	168	8
Ignition	166	7.1.7	+	+	+	+	+	+	168	7
High speed particles <sup>c</sup>	166	7.2.2	X	X	X	X	X	X	168	9
Molten metals and hot solids <sup>c</sup>	166	7.2.3						+	168	10 and 11
Droplets and splashes of liquids <sup>c</sup>	166	7.2.4		+					168	12
Large dust particles <sup>c</sup>	166	7.2.5			+				168	13
Gas and fine dust particles <sup>c</sup>	166	7.2.6				+			168	14
Short circuit electric arc	166	7.2.7					+		Visual inspection	
Lateral protection <sup>d</sup>	166	7.2.8	X	X	X	X	X	X	168	19
High speed particles at extremes of temperature <sup>c</sup>	166	7.3.4	X	X	X	X	X	X	168	9
Marking	166	9.3	+	+	+	+	+	+	Visual inspection	
<p>Key</p> <p>+ Requirement is specified</p> <p>Empty field Requirement is not specified</p> <p>X Optional requirement</p> <p><sup>a</sup> Transmittance need only be assessed if the eye-protector is a goggle or face-shield, and can be fitted with a filter(s) for use against optical radiation.</p> <p><sup>b</sup> Complete eye-protectors fitted with oculars meeting the minimum robustness requirement only, shall only be tested for lateral impact.</p> <p><sup>c</sup> These requirements when applied to frames supplied without oculars shall be tested with the appropriate oculars fitted.</p> <p><sup>d</sup> Lateral protection assessment is mandatory if high-speed particle protection is claimed.</p>										

**EN 166:2001 (E)**

**Table 10 — Type examination test schedule for oculars**

Requirement				according to		Quantity of test sample		
				EN	Clause		EN	Clause
Marking				166	9.1/9.2/9.4	Visual inspection	All	
Information				166	10	Visual inspection	All	
Quality of material and surface				166	7.1.3	167	5	6
Refractive powers				166	7.1.2.1	167	3	6
Thermal stability <sup>d</sup>				166	7.1.5.1	168	5	3
Transmittance				166	7.1.2.2.1	167	6	6
				169	4			
				170	4			
				171	4			
				172	4.1			
Variation in transmittance				166	7.1.2.2.3	167	7	6
Diffusion of light				166	7.1.2.3	167	4	6
Ocular reflectance				166	7.3.3	167	8	6
Short circuit electric arc <sup>a</sup>				166	7.2.7	By measuring		6
UV stability <sup>d</sup>				166	7.1.5.2	168	6	3
Minimum robustness <sup>b</sup>				166	7.1.4.1	168	4	8
Increased robustness <sup>c</sup> <i>Impact point / Test temperature °C</i>	1		+ 55	166	7.1.4.2.1	168	3.1	2
			- 5					2
	2		+ 55					2
			- 5					2
Ignition				166	7.1.7	168	7	3
Molten metals and hot solids <sup>a, c</sup>				166	7.2.3	168	10 and 11	3
Surface damage by fine particles <sup>c</sup>				166	7.3.1	168	15	4
Fogging <sup>c</sup>				166	7.3.2	168	16	4
<sup>a</sup> Compliance of the ocular alone does not fully satisfy the relevant requirement clause. <sup>b</sup> If the ocular is to be subjected to the increased robustness test then the minimum robustness test need not be conducted. <sup>c</sup> Only one test shall be performed on each ocular. <sup>d</sup> If the ocular does not cover both eyes, ensure that each test is performed on 2 samples for one eye position and on 1 sample for the other e.g. 1 left and 2 right oculars.								
NOTE 1	Sample quantities correspond to eye positions, e.g. 6 = 3 left + 3 right.							
NOTE 2	It is recommended that testing be performed in the order shown in flowchart 1.							
NOTE 3	The type test evaluation shall allow no defectives and not account shall be taken of measurement uncertainties.							
NOTE 4	Tests conducted in conjunction with the frames (see Table 11) need not be repeated.							

Flowchart 1 - Testing of oculars

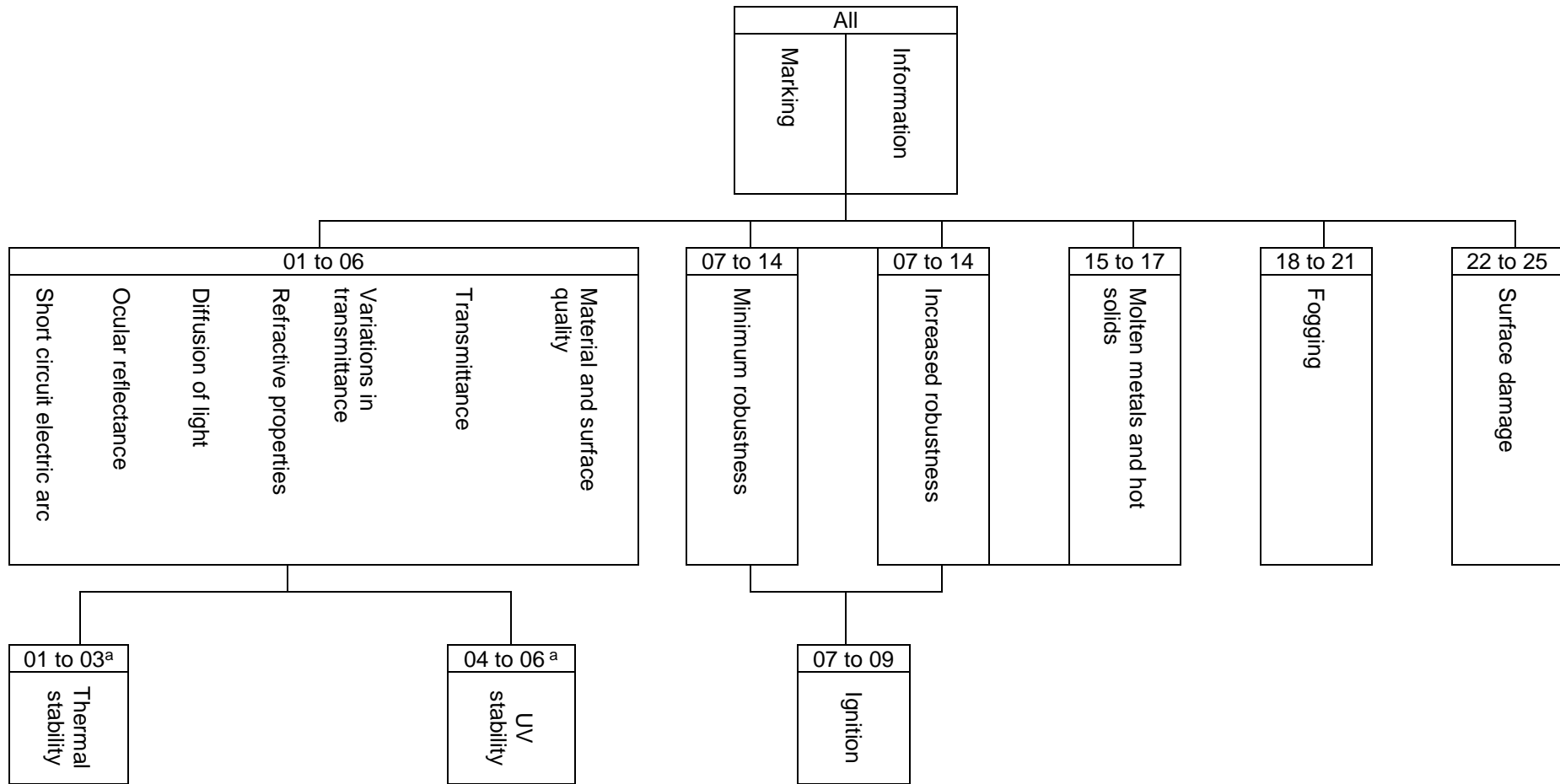

<sup>a</sup> If the ocular does not cover both eyes, ensure that each test is performed on 2 samples for one eye position and on 1 sample for the other eye position – e.g. 1 left and 2 right oculars.

NOTE Sample numbers correspond to eye positions, e.g. 01 to 06 = 3 left + 3 right.

Table 11 — Type examination test schedule for complete eye-protectors

Requirement				according to		Testing according to		Quantity of test samples
				EN	Clause	EN	Clause	
Marking				166	9.1/9.3/9.4	Visual inspection		All
Information				166	10	Visual inspection		All
Construction and materials				166	6.1/6.2	Visual inspection / Manufacturer's certificates		All
Head bands				166	6.3	By measuring		3
Quality of material and surface <sup>b</sup>				166	7.1.3	167	5	3
Field of vision				166	7.1.1	168	18	3
Refractive properties				166	7.1.2.1	167	3	3
Thermal stability <sup>c</sup>				166	7.1.5.1	168	5	3
Transmittance of oculars <sup>b</sup>				166	7.1.2.2.1	167	6	3
				169	4			
				170	4			
				171	4			
				172	4.1			
Transmittance of frames				166	7.1.2.2.2.	167	6	3
Variations in transmittance <sup>b</sup>				166	7.1.2.2.3	167	7	3
Diffusion of light <sup>b</sup>				166	7.1.2.3	167	4	3
Ocular reflectance <sup>b</sup>				166	7.3.3	167	8	3
Short circuit electric arc				166	7.2.7	Visual inspection & by measuring		3
Lateral protection				166	7.2.8	168	19	3
UV stability <sup>c</sup>				166	7.1.5.2	168	6	3
Minimum robustness <sup>b</sup>				166	7.1.4.1	168	4	8
Increased robustness <sup>a</sup> <b>Impact point</b> / Test temperature °C		1	+ 55	166	7.1.4.2.2	168	3.2	2
			- 5					2
		2	+ 55					2
			- 5					2
		3	+ 55					1
			- 5					1
		4	+ 55					1
			- 5					1
Corrosion				166	7.1.6	168	8	3
Ignition				166	7.1.7	168	7	3
High speed particles : <b>Impact point</b>		1		166	7.2.2	168	9	4
								4
								2
								2
High speed particles at extremes of temperature: <b>Impact point</b> / Test temperature °C		1	+ 55	166	7.3.4	168	9	2
			- 5					2
		2	+ 55					2
			- 5					2
		3	+ 55					1
			- 5					1
		4	+ 55					1
			- 5					1
Molten metals and hot solids				166	7.2.3	168	10 and 11	3
Droplets and splashes				166	7.2.4	168	12	3
Large dust				166	7.2.5	168	13	3
Gas and fine dust particles				166	7.2.6	168	14	3
Surface damage by fine particles <sup>b</sup>				166	7.3.1	168	15	4
Fogging <sup>b</sup>				166	7.3.2	168	16	4
<p><sup>a</sup> Frames fitted with oculars meeting only the minimum robustness requirements, shall only be tested for lateral impact.</p> <p><sup>b</sup> If the oculars have been tested for the requirements (see Table 10), these tests on the oculars need not be repeated.</p> <p><sup>c</sup> Ensure that each test is performed on 2 samples for 1 eye position and on 1 sample for the other eye position (e.g. – 1 left, 2 right).</p>								
NOTE 1				It is recommended that testing be performed in the order shown in flowchart 2.				
NOTE 2				The type test evaluation shall allow no defectives and no account shall be taken of measurement uncertainties.				



Flowchart 2 – Testing of complete eye-protectors

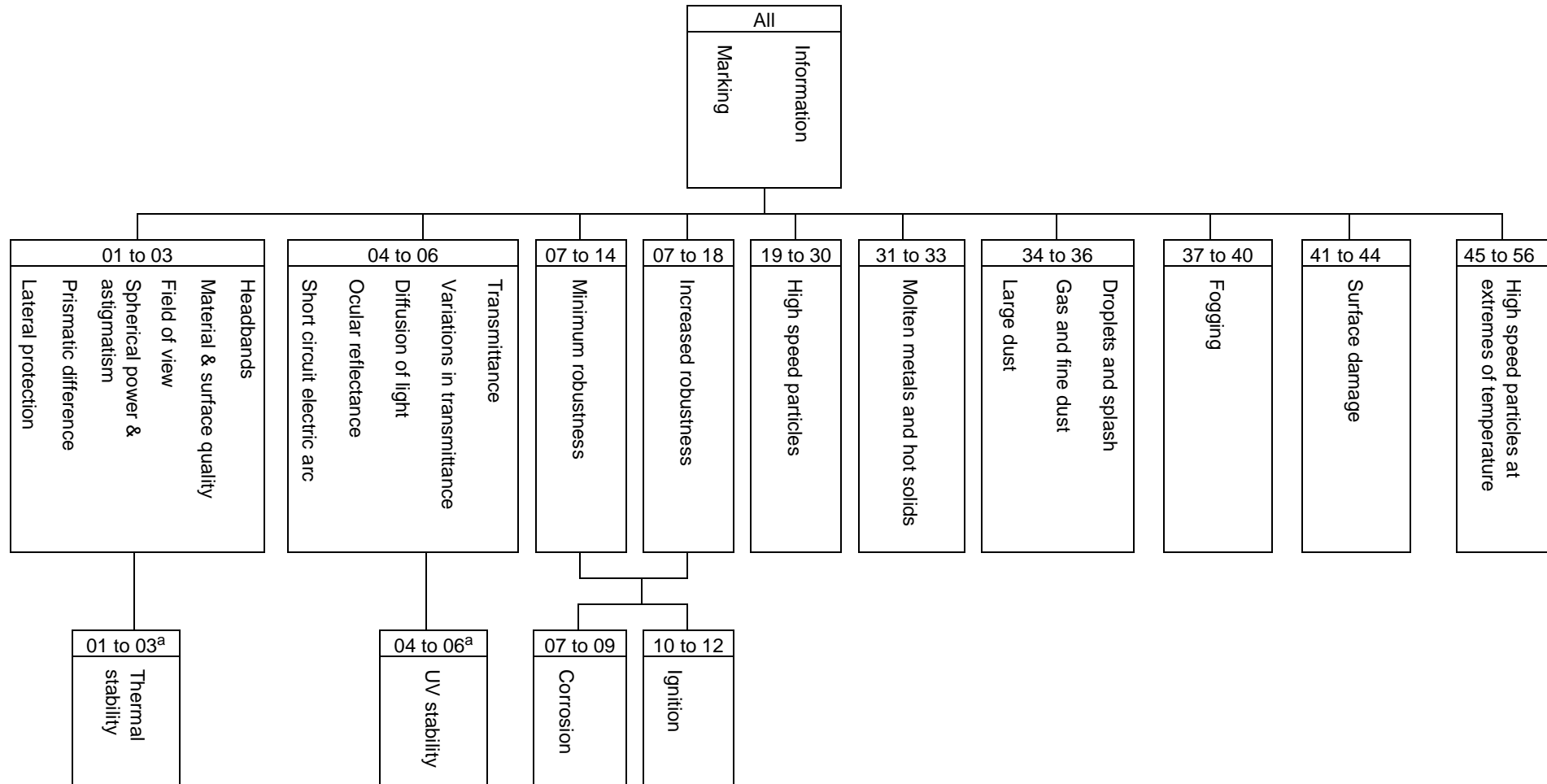

<sup>a</sup> Ensure that each test is performed on 2 samples for 1 eye position and on 1 sample for the other eye position (e.g. – 1 left, 2 right)

NOTE If the properties to be determined at samples 4 to 6 and 37 to 44 were already measured on the oculars, measurements need not be repeated.

**Table 12 — Application of eye-protector types for the various fields of use**

		Type of eye protector				Testing	
		Symbol	According to EN 166 clause	Spectacles	Goggles	Face-shields	According to EN 168 clause
Basic use		No symbol	a	+	+	+	a
Increased robustness		S	7.1.4.2	+	+	+	clause 3.1/3.2 22 mm ball at 5.1 m/s
Optical radiation		b	7.2.1	+	+	+	c
High speed particles <sup>d</sup>	Low energy impact	F	7.2.2	+	+	+	clause 9 6 mm ball at 45 m/s
	Medium energy impact	B	7.2.2	0	+	+	clause 9 6 mm ball at 120 m/s
	High energy impact	A	7.2.2	0	0	+	clause 9 6 mm ball at 190 m/s
Liquid droplets		3	7.2.4	0	+	0	12.1
Liquid splashes		3	7.2.4	0	0	+	12.2
Large dust particles		4	7.2.5	0	+	0	13
Gas & fine dust particles		5	7.2.6	0	+	0	14
Short circuit electric arc		8	7.2.7	0	0	+	e
Molten metals & hot solids		g <sup>f</sup>	7.2.3	0	+	+	10 and 11
High speed particles at extremes of temperature <sup>g</sup>		T	7.3.4	g	g	g	clause 9

**Key**

+ Allowable application

0 Prohibited application

a For basic use, and all other fields of use, the basic requirements specified in 6.1 shall be satisfied.

b The symbol for optical radiation consists of the scale number defined in clause 5 for the various types of filter (welding, ultraviolet, infrared or sunglare) and is marked on the ocular. If optical radiation is the only field of use for which protection is required then the frame need only comply with the requirements for basic use. Goggle and face-shield housings, where applicable, shall be marked with the maximum compatible filter scale number.

c See EN 169, EN 170, EN 171, EN 172, or EN 379 dependent on type of filter.

d If the symbols F, B and A are not common to both the ocular and the frame then it is the lower level which shall be assigned to the complete eye-protector.

e For a face-shield to comply with field of use symbol 8 it shall be fitted with a filter of scale number 2-1,2 or 3-1,2 and have a minimum thickness of 1,4 mm.

f For an eye-protector to comply with field of use symbol 9 both the frame and ocular shall be marked with this symbol together with one of the symbols F, B or A.

g Symbol T is used in conjunction with either F, B or A to indicate that the eye-protector conforms to the high-speed particle classification at extremes of temperature.

## 9 Marking

### 9.1 General

All markings shall be clear and permanent.

The marking shall be fully visible when the complete eye-protector is assembled and shall not encroach into the minimum field of vision defined in 7.1.1. Outside of this area the marking shall not impede vision when worn.

The number of this standard shall be applied to frames and housings but need not be applied to oculars.

The frame and ocular shall be marked separately. If the ocular and frame form a single unit, the complete marking shall be applied to the frame (see 9.4).

### 9.2 Ocular marking

The marking of oculars shall contain the relevant technical information presented as follows:

	8	9	K	N	R	O ▽
Scale number (filters only)						
Identification of the manufacturer						
Optical class (except for cover plates)						
Symbol for mechanical strength (where applicable)						
Symbol for resistance to short circuit Electric arc (where applicable)						
Symbol for non-adherence of molten metal and resistance to penetration of hot solids (where applicable)						
Symbol for resistance to surface damage by fine particles (where applicable)						
Symbol for resistance to fogging of oculars (where applicable)						
Symbol for enhanced reflectance (where applicable)						
Symbol for original or replacement ocular (optional)						

In addition, the ocular marking may include a mark to assist correct fitting of laminated oculars (see 9.2.11).

#### 9.2.1 Scale number

See clause 4, Table 1.

#### 9.2.2 Identification of the manufacturer

The manufacturer's identification mark shall be included in the marking in the position shown and may consist of one or more elements.

#### 9.2.3 Optical class

One of the three optical classes defined in 7.1.2 shall be included in the marking in the position shown, except in the case of cover plates which are always required to be class 1.

**9.2.4 Mechanical strength**

Symbols relating to oculars which withstand one of the various mechanical strength tests shall be included in the marking ; the identification of the symbols is given in Table 13.

**Table 13 — Identification symbols for mechanical strength**

Symbol	Mechanical strength requirement
No symbol	Minimum robustness (see 7.1.4.1)
S	Increased robustness (see 7.1.4.2)
F	Low energy impact (see 7.2.2)
B	Medium energy impact (see 7.2.2)
A	High energy impact (see 7.2.2)

**9.2.5 Resistance to short circuit electric arc**

Oculars which have satisfied the requirements specified in 7.2.7 shall be marked with the number 8.

**9.2.6 Non-adherence of molten metal and resistance to penetration of hot solids**

Oculars which have satisfied the requirements specified in 7.2.3 shall be marked with the number 9.

**9.2.7 Resistance to surface damage by fine particles**

Oculars which meet the requirements of 7.3.1 shall be marked with the symbol K.

**9.2.8 Resistance to fogging of oculars**

Oculars which meet the requirements of 7.3.2 shall be marked with the symbol N.

**9.2.9 Original/replacement oculars**

To identify if an ocular is an original or a replacement, the manufacturer may use the symbols 'O' (original) or 'V' (replacement).

**9.2.10 Resistance to high speed particles at extremes of temperature**

Oculars which meet the requirements of 7.3.4 shall be marked with one of the impact symbols followed by the letter "T". i.e. FT, BT or AT.

**9.2.11 Marking of laminated oculars**

Certain types of flat laminated oculars may need to be specifically orientated in the frame such that the hazardous splintering layer faces outwards, away from the eye. Such oculars shall be identified with a suitable mark on the nasal edge of the front face to help prevent incorrect assembly in the frame.

9.2.12 Examples of ocular marking

a) welding filter

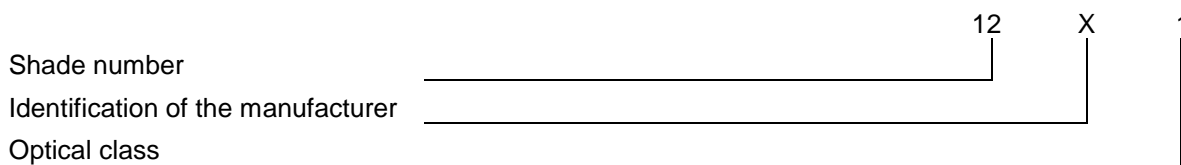

b) welding filter with mechanical strength function

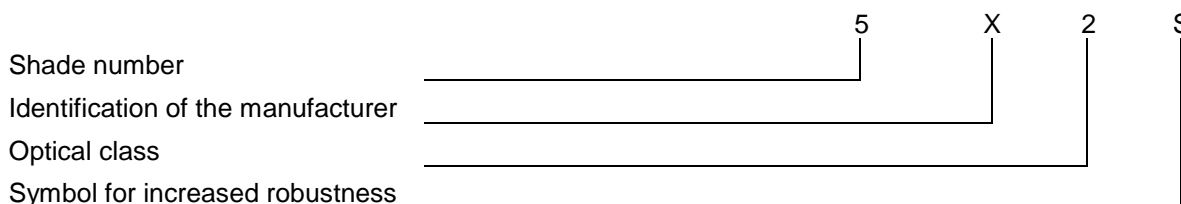

c) ultraviolet filters

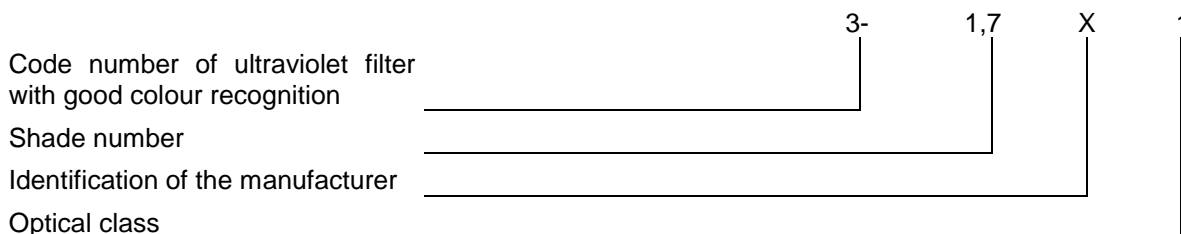

d) ultraviolet filters with mechanical strength function and resistant to short circuit electric arc

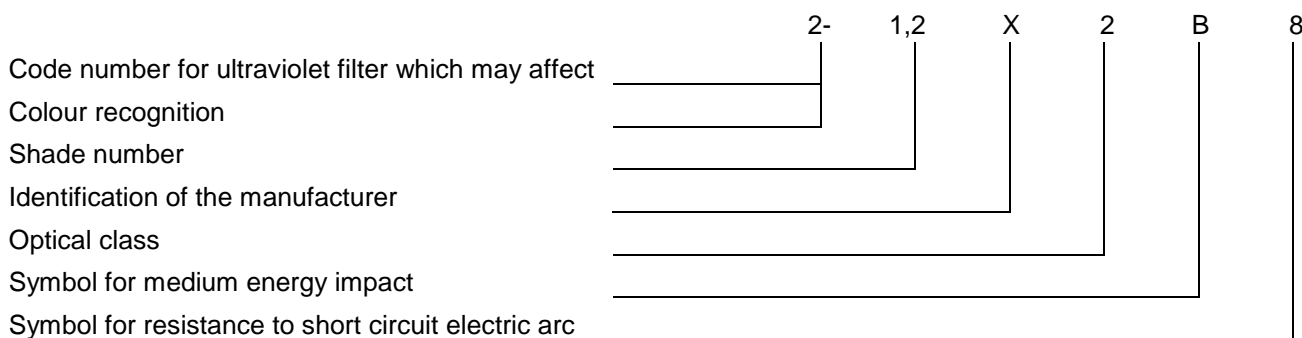

e) infrared filters

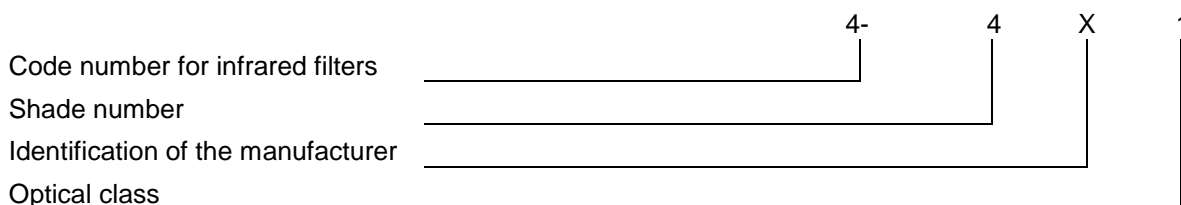

**EN 166:2001 (E)**

f) infrared filters with mechanical strength function and non-adherence of molten metals and resistance to penetration of hot solids function

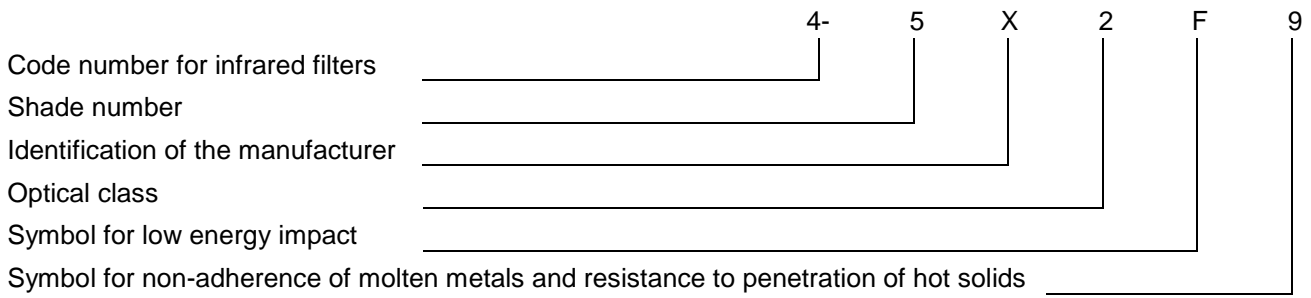

g) welding filters with enhanced reflectance

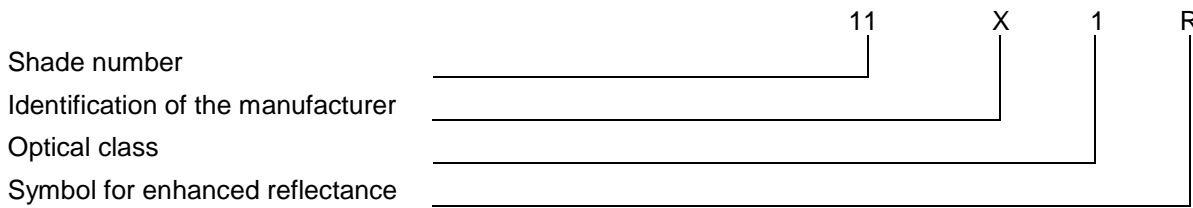

For marking photochromic sunglare filters, the scale numbers corresponding to light and dark shall be separated by the symbol < for example 5 - 1,4< 2,5 X 1.

For marking graduated sunglare filters, the scale numbers corresponding to the light and dark sections shall be separated by the symbol /, for example 5 - 1,1/1,7X2.

h) sunglare filters with mechanical strength function, original ocular

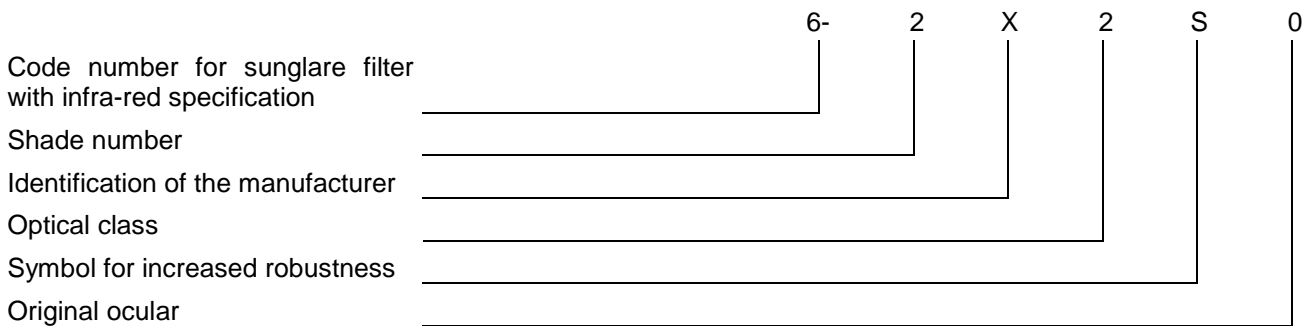

i) safety ocular without filtering action, replacement ocular

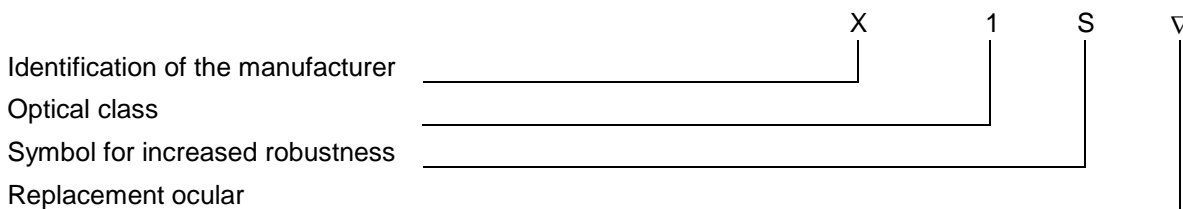

j) safety ocular without filtering action and highest level of mechanical strength function at extremes of temperature

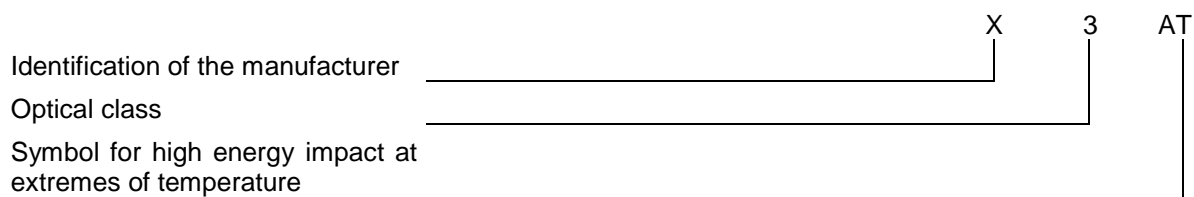

k) welding filter with mechanical strength function and resistant to surface damage by fine particles.

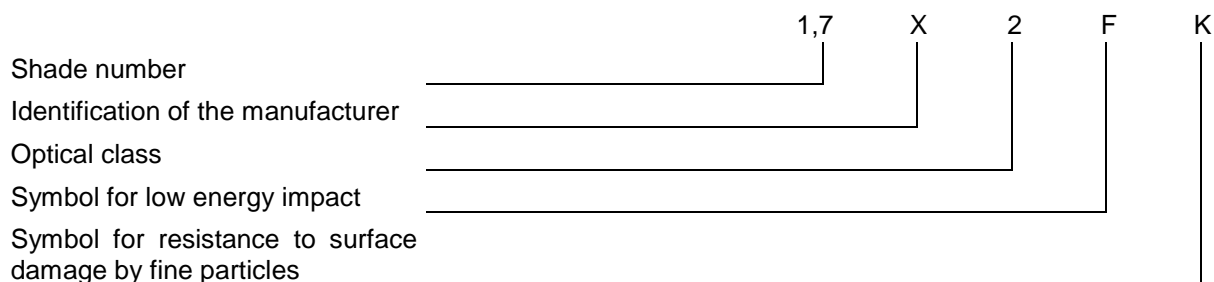

l) safety ocular with mechanical strength function, non-adherence of molten metals and resistance to penetration of hot solids function and resistant to fogging

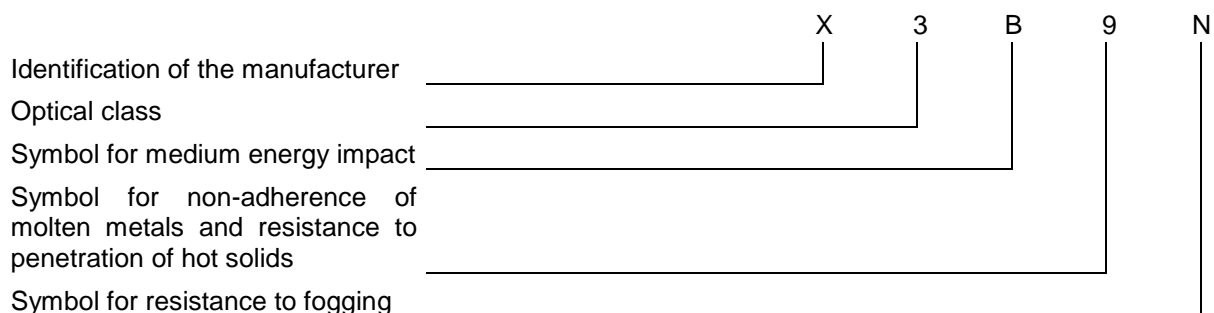

m) ultraviolet filter with mechanical strength function, resistant to surface damage by fine particles and resistant to fogging

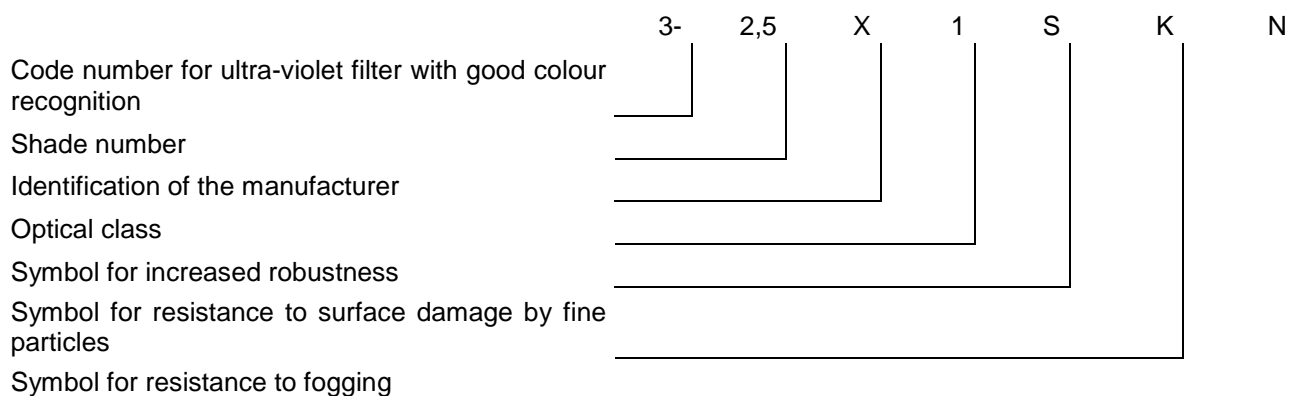

n) cover plate



**EN 166:2001 (E)**

o) cover plate resistant to surface damage by fine particles



**9.3 Frame marking**

The marking of frames shall contain the relevant technical information presented as follows:

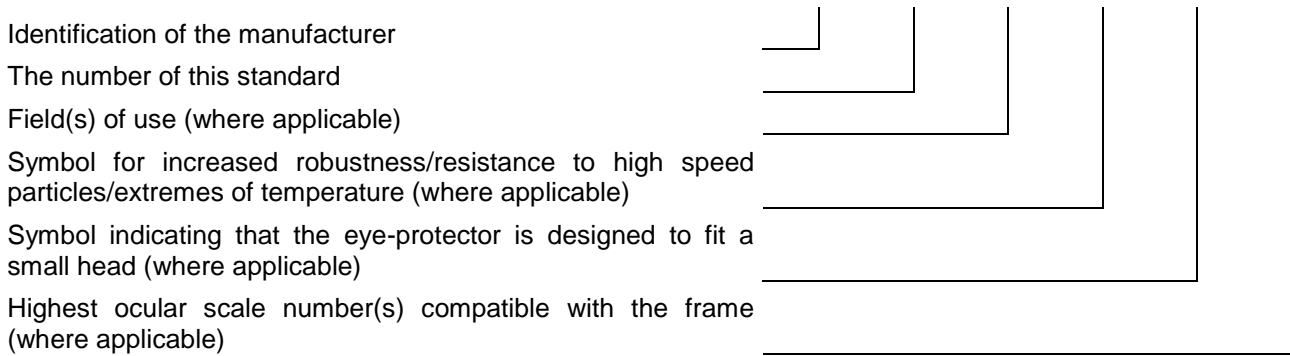

**9.3.1 Identification of the manufacturer**

The manufacturer's identification mark shall be included in the marking in the position shown and may consist of one or more elements.

**9.3.2 The number of this standard**

The number of this standard shall be included in the marking in the position shown and shall comprise at least the digits 166.

**9.3.3 Field of use**

The frames of eye-protectors shall be marked to indicate their intended field of use. The marking symbol shall comprise a single digit number, as defined in Table 14. If the eye-protector covers more than one field of use the appropriate numbers shall be applied consecutively on the frame in ascending numerical value.

**Table 14 — Symbols for field of use**

Symbol	Designation	Description of the field of use
No symbol	Basic use	Unspecified mechanical hazards and hazards arising from ultraviolet, visible, infra-red and solar radiation
3	Liquids	Liquids (droplets or splashes)
4	Large dust particles	Dust with a particle size of > 5 µm
5	Gas and fine dust particles	Gases, vapours, sprays, smoke and dust with a particle size < 5 µm
8	Short circuit electric arc	Electrical arc due to a short circuit in electrical equipment
9	Molten metals and hot solids	Splashes of molten metals and penetration of hot solids

**9.3.4 Increased robustness and resistance to high speed particles**

Frames which satisfy the requirements of 7.1.4.2 and 7.2.2 shall be marked with the appropriate symbol given in Table 15.



Table 15 — Symbols for resistance to increased robustness and high speed particles

Symbol	Description of the level of impact
S	Increased robustness
F	Low energy impact
B	Medium energy impact
A	High energy impact

NOTE

Symbol S and F may be applied to all types of eye protectors ;  
Symbol B may be applied to goggles and face-shields only ;  
Symbol A may be applied to face-shields only.

### 9.3.5 Resistance to high speed particles at extremes of temperature

Frames which meet the requirements of 7.3.4 shall be marked with one of the impact symbols followed by the letter T. i.e. FT, BT or AT.

### 9.3.6 Frames designed to fit a small head

If the frame is designed to fit a small head it shall be marked with the letter H.

### 9.3.7 Highest ocular scale number

Housings of goggles and face shields intended to provide protection against optical radiation shall be marked with the maximum scale number(s) of filtering ocular which may be fitted.

### 9.3.8 Examples of frame marking

a) frames used for protection against liquids (droplets or splashes)

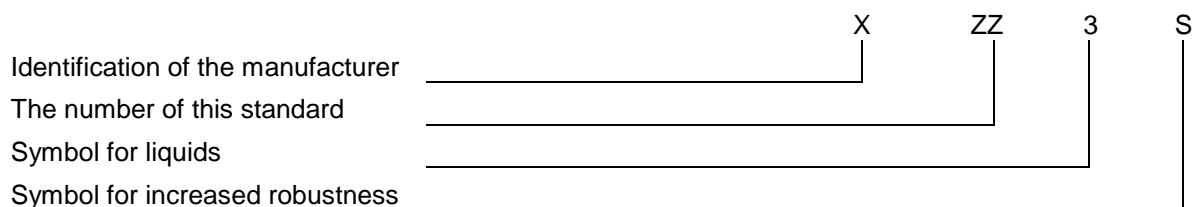

b) frames used for protection against large dust particles

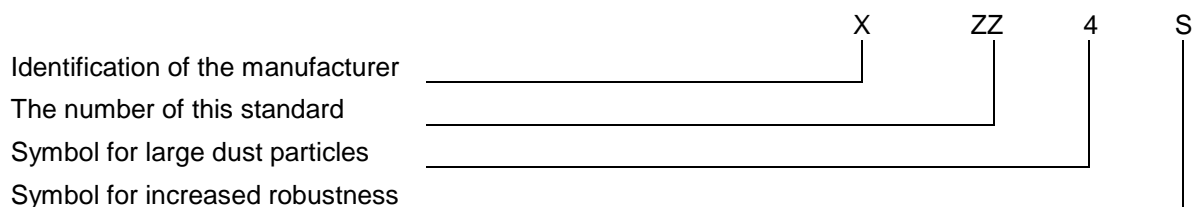

In place of symbols 3 and 4 in the above examples the symbols 5, 8 and 9 would be used to indicate frames for protection against gases and fine dusts (5), short circuit electric arc (8) and molten metals and hot solids (9).

**EN 166:2001 (E)**

c) frames used for protection against solar radiation and designed to suit a small head

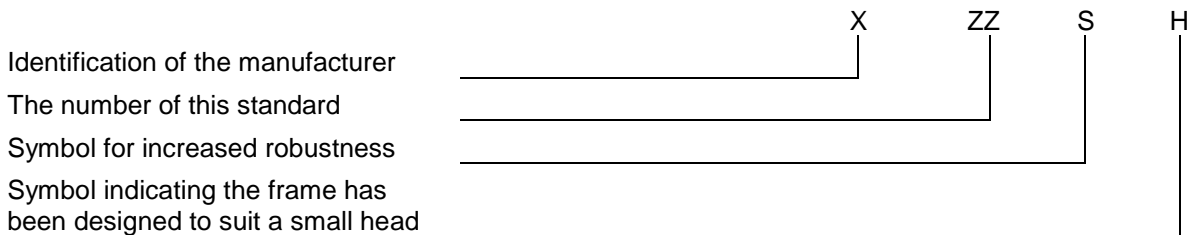

The marking example shown above would also apply to frames for basic use and spectacle frames for protection against ultraviolet and/or infrared radiation.

d) frames used for protection against UV radiation

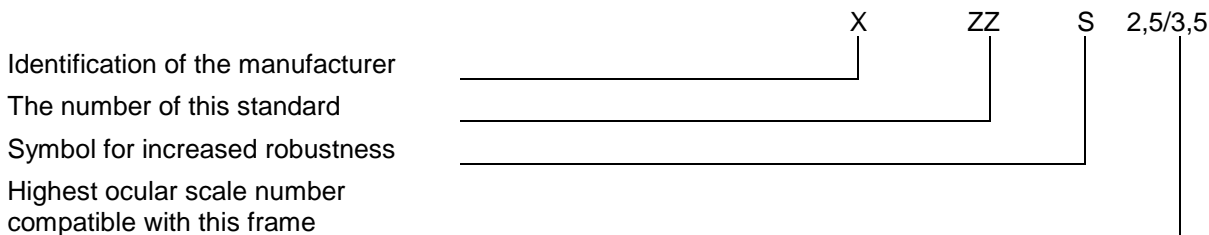

This marking would be applied to a goggle or faceshield frame intended for use with UV filter(s) (with or without good colour recognition) up to a scale number of 2.5 or 3.5

e) frames used for protection against high speed particles (low energy impact)

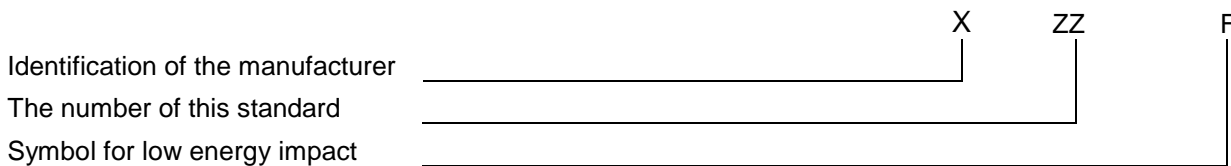

In place of the symbol F in the above example the symbol B would be used in the marking of a frame used for protection against high speed particles of medium energy impact, and the symbol A in the marking of a frame used for protection against high speed particles of high energy impact. Additionally, if the frame was for use against high-speed particles at extremes of temperature the impact symbols would be followed by the letter T; i.e. FT, BT or AT.

f) frames for several fields of use

Eye-protector frames may be marked to show more than one field of use and to indicate protection against high-speed particles. The following example is for a frame for protection against liquids, large dust particles, molten metals and hot solids and high-speed particles medium energy impact at extremes of temperature.

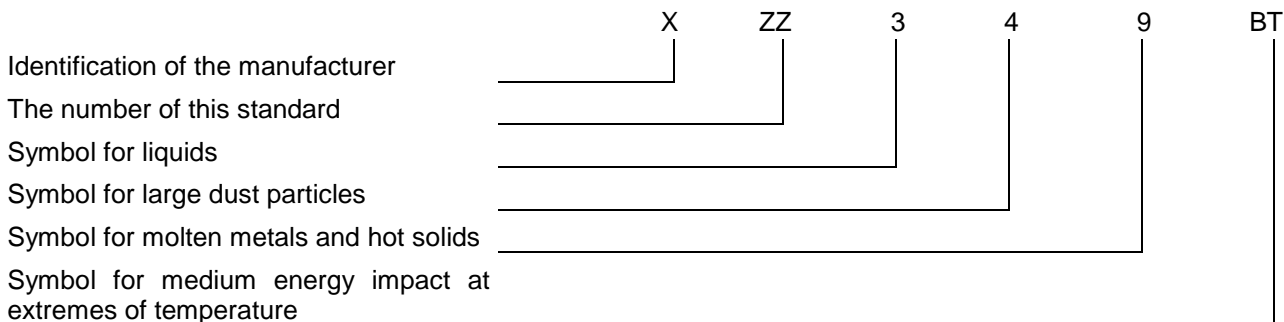

#### 9.4 Marking of eye-protectors where the frame and ocular form a single unit

Eye-protectors in which the frame and ocular form a single unit shall be marked on the frame.

The marking shall comprise the full ocular marking, a hyphen, the number of this standard and then any appropriate symbols for field of use and level of impact.

The following example illustrate the principle defined above:

Single unit eye-protector with infrared filter effect resistant to low energy impact, resistant to adherence of molten metal and penetration of hot solids, with the frame offering protection against liquids, molten metals and hot solids and being resistant to low energy impact.

	4-	4	X	2	F	9	-ZZ	3	9	F
Code number for infra-red filters	_____									
Shade number	_____									
Identification of the manufacturer	_____									
Optical class	_____									
Symbol for low energy impact	_____									
Symbol for molten metals and hot solids	_____									
The number of this standard	_____									
Symbol for liquids	_____									
Symbol for molten metals and hot solids	_____									
Symbol for low energy impact	_____									

#### 10 Information supplied by the manufacturer

The manufacturer shall provide with each eye-protector, replacement ocular and replacement frame at least the following information:

- a) name and address of the manufacturer;
- b) the number of this standard;
- c) the eye-protector model identification;
- d) instructions for storage, use and maintenance;
- e) specific instructions for cleaning and disinfection;
- f) details of the field of use, protection capabilities and performance characteristics;
- g) details of suitable accessories and spare parts. Instructions for fitting shall be included with the original eye-protector and/or with the spare part or accessory;
- h) the obsolescence deadline or period of obsolescence, if applicable, for the complete eye-protector and/or component parts;
- i) the type of packaging suitable for transport, if applicable;
- j) the significance of the marking on the frame and the ocular;
- k) a warning that optical class 3 oculars are not intended for long term use, if applicable;
- l) a warning concerning the compatibility of marking (see notes (4), (5) and (6) to Table 12);
- m) a warning that materials which may come into contact with the wearer's skin could cause allergic reactions to susceptible individuals;
- n) a warning that scratched or damaged oculars should be replaced;

## EN 166:2001 (E)

- o) a warning that eye-protectors against high speed particles worn over standard ophthalmic spectacles may transmit impacts, thus creating a hazard to the wearer.
- p) a note to instruct that if protection against high speed particles at extremes of temperature is required then the selected eye-protector should be marked with the letter T immediately after the impact letter, i.e. FT, BT or AT. If the impact letter is not followed by the letter T then the eye protector shall only be used against high speed particles at room temperature.

## Annex ZA (informative)

### Clauses of this European Standard addressing essential requirements or other provisions of EU Directives

This European Standard has been prepared under a mandate given to CEN by the European Commission and the European Free Trade Association and supports essential requirements of EU Directive 89/686/EEC.

WARNING: Other requirements and other EU Directives may be applicable to the product(s) falling within the scope of this standard.

The following clauses of this standard are likely to support requirements of Directive 89/686/EEC, Annex II:

**Table ZA.1 — Relationship between this standard and Directive 89/686/EEC**

EC- DIRECTIVE 89/686/EEC, Annex II		Clauses of this standard
1.1	Design principles	6.1, 6.2, 6.3
1.1.1	Ergonomics	6.3, 7.1.1
1.1.2	Levels and classes of protection	7.1, 7.2, 7.3
1.1.2.1	Highest level of protection possible	7.1, 7.2, 7.3
1.1.2.2	Classes of protection appropriate to different levels of risk	7.1, 7.2, 7.3
1.2.1.1	Suitable constituent materials	6.2
1.2.1.2	Satisfactory surface condition of all PPE parts in contact with the user	6.1
1.2.1.3	Maximum permissible user impediment	6.3, 7.1.1
1.3	Comfort and efficiency	6.3, 7.1.1
1.3.1	Adaptation of PPE to user morphology	6.3, 7.1.1
1.3.2	Lightness and design strength	7.1.4, 7.2.2
1.4	Information supplied by the manufacturer	10
2.1	PPE incorporating adjustments systems	6.3
2.3	PPE for the face, eyes and respiratory tracts	All
2.4	PPE subject to ageing	7.1.5
2.9	PPE incorporating components which can be adjusted or removed by the user	6.3, 9.2.8
2.12	PPE bearing one or more identification marks directly or indirectly relating to health and safety	9
2.14	Multi-risk PPE	All
3.1	Protection against mechanical impact	7.1.4, 7.2.2
3.1.1	Impact caused by falling or projecting objects and collision of parts of the body with an obstacle.	7.1.4, 7.2.2
3.9	Radiation protection	7.2.1

Compliance with the clauses of this standard provides one means of conforming with the specific essential requirements of the Directive concerned and associated EFTA regulations.

---

---

# BSI — British Standards Institution

BSI is the independent national body responsible for preparing British Standards. It presents the UK view on standards in Europe and at the international level. It is incorporated by Royal Charter.

## Revisions

British Standards are updated by amendment or revision. Users of British Standards should make sure that they possess the latest amendments or editions.

It is the constant aim of BSI to improve the quality of our products and services. We would be grateful if anyone finding an inaccuracy or ambiguity while using this British Standard would inform the Secretary of the technical committee responsible, the identity of which can be found on the inside front cover. Tel: +44 (0)20 8996 9000. Fax: +44 (0)20 8996 7400.

BSI offers members an individual updating service called PLUS which ensures that subscribers automatically receive the latest editions of standards.

## Buying standards

Orders for all BSI, international and foreign standards publications should be addressed to Customer Services. Tel: +44 (0)20 8996 9001. Fax: +44 (0)20 8996 7001. Email: [orders@bsi-global.com](mailto:orders@bsi-global.com). Standards are also available from the BSI website at <http://www.bsi-global.com>.

In response to orders for international standards, it is BSI policy to supply the BSI implementation of those that have been published as British Standards, unless otherwise requested.

## Information on standards

BSI provides a wide range of information on national, European and international standards through its Library and its Technical Help to Exporters Service. Various BSI electronic information services are also available which give details on all its products and services. Contact the Information Centre. Tel: +44 (0)20 8996 7111. Fax: +44 (0)20 8996 7048. Email: [info@bsi-global.com](mailto:info@bsi-global.com).

Subscribing members of BSI are kept up to date with standards developments and receive substantial discounts on the purchase price of standards. For details of these and other benefits contact Membership Administration. Tel: +44 (0)20 8996 7002. Fax: +44 (0)20 8996 7001. Email: [membership@bsi-global.com](mailto:membership@bsi-global.com).

Information regarding online access to British Standards via British Standards Online can be found at <http://www.bsi-global.com/bsonline>.

Further information about BSI is available on the BSI website at <http://www.bsi-global.com>.

## Copyright

Copyright subsists in all BSI publications. BSI also holds the copyright, in the UK, of the publications of the international standardization bodies. Except as permitted under the Copyright, Designs and Patents Act 1988 no extract may be reproduced, stored in a retrieval system or transmitted in any form or by any means – electronic, photocopying, recording or otherwise – without prior written permission from BSI.

This does not preclude the free use, in the course of implementing the standard, of necessary details such as symbols, and size, type or grade designations. If these details are to be used for any other purpose than implementation then the prior written permission of BSI must be obtained.

Details and advice can be obtained from the Copyright & Licensing Manager. Tel: +44 (0)20 8996 7070. Fax: +44 (0)20 8996 7553. Email: [copyright@bsi-global.com](mailto:copyright@bsi-global.com).