

BS EN 131-6:2015



BSI Standards Publication

Ladders

Part 6: Telescopic ladders

bsi.

...making excellence a habit.™

National foreword

This British Standard is the UK implementation of EN 131-6:2015.

BSI, as a member of CEN, is obliged to publish EN 131-6 as a British Standard. However, attention is drawn to the fact that during the development of this European Standard, the UK committee voted against its approval as a European Standard.

In the opinion of the UK committee the test requirements in EN 131-6 are different and in some cases less demanding than those in EN 131-2. To the user an extended telescopic ladder and a conventional ladder are the same product. However because of the different requirements between EN 131-6 and EN 131-2, a telescopic ladder certified compliant to EN 131 will not have been subjected to the same tests as a conventional ladder similarly certified compliant to EN 131.

The UK participation in its preparation was entrusted to Technical Committee B/512, Ladders.

A list of organizations represented on this committee can be obtained on request to its secretary.

This publication does not purport to include all the necessary provisions of a contract. Users are responsible for its correct application.

© The British Standards Institution 2015.
Published by BSI Standards Limited 2015

ISBN 978 0 580 81769 4

ICS 97.145

Compliance with a British Standard cannot confer immunity from legal obligations.

This British Standard was published under the authority of the Standards Policy and Strategy Committee on 31 March 2015.

Amendments/corrigenda issued since publication

| Date | Text affected |
|------|---------------|
|------|---------------|

ICS 97.145

English Version

Ladders - Part 6: Telescopic ladders

Échelles - Partie 6: Échelles télescopiques

Leitern - Teil 6: Teleskopleitern

This European Standard was approved by CEN on 3 January 2015.

CEN members are bound to comply with the CEN/CENELEC Internal Regulations which stipulate the conditions for giving this European Standard the status of a national standard without any alteration. Up-to-date lists and bibliographical references concerning such national standards may be obtained on application to the CEN-CENELEC Management Centre or to any CEN member.

This European Standard exists in three official versions (English, French, German). A version in any other language made by translation under the responsibility of a CEN member into its own language and notified to the CEN-CENELEC Management Centre has the same status as the official versions.

CEN members are the national standards bodies of Austria, Belgium, Bulgaria, Croatia, Cyprus, Czech Republic, Denmark, Estonia, Finland, Former Yugoslav Republic of Macedonia, France, Germany, Greece, Hungary, Iceland, Ireland, Italy, Latvia, Lithuania, Luxembourg, Malta, Netherlands, Norway, Poland, Portugal, Romania, Slovakia, Slovenia, Spain, Sweden, Switzerland, Turkey and United Kingdom.



EUROPEAN COMMITTEE FOR STANDARDIZATION
COMITÉ EUROPÉEN DE NORMALISATION
EUROPÄISCHES KOMITEE FÜR NORMUNG

CEN-CENELEC Management Centre: Avenue Marnix 17, B-1000 Brussels

Contents

Page

| | |
|---|----|
| Foreword..... | 3 |
| 1 Scope | 4 |
| 2 Normative references | 4 |
| 3 Terms and definitions | 4 |
| 4 Functional dimensions..... | 7 |
| 4.1 General dimensions | 7 |
| 4.2 Specific dimensions | 7 |
| 5 Requirements | 7 |
| 5.1 General requirements..... | 7 |
| 5.2 Distance between rungs/steps | 7 |
| 5.3 Additional requirements for the top of leaning ladders..... | 7 |
| 5.4 Locking of the rung/step sections | 7 |
| 5.5 Design | 8 |
| 6 Testing | 8 |
| 6.1 General..... | 8 |
| 6.2 Drop test | 8 |
| 6.3 Strength test of stiles | 9 |
| 6.4 Bending test of the stiles | 9 |
| 6.5 Lateral deflection test of the ladder | 10 |
| 6.6 Bottom stile ends test | 11 |
| 6.7 Rungs/steps strength test | 11 |
| 6.7.1 Rungs/steps strength test – locked position | 11 |
| 6.7.2 Rungs/steps strength test – unlocked position | 12 |
| 6.7.3 Torsion test of rungs/steps | 13 |
| 6.7.4 Pull out test of rung/step | 13 |
| 6.8 Test of opening restraints and hinges of standing ladders | 13 |
| 6.9 Test of locking mechanism..... | 14 |
| 6.9.1 Cyclic test of locking mechanism | 14 |
| 6.9.2 Static test of locking mechanism | 15 |
| 6.9.3 Cyclic test of hinge joints | 15 |
| 6.9.4 Requirements | 15 |
| 6.10 Feet pull test..... | 16 |
| 6.11 Torsion on ladder length..... | 16 |
| 6.12 Test methods for plastic ladders | 17 |
| 6.13 Test methods for plastic rung/step brackets | 17 |
| 7 Marking and User Instruction | 17 |
| 7.1 General..... | 17 |
| 7.2 Marking | 17 |
| 7.3 User instruction | 18 |
| Annex A (normative) Test sequence..... | 19 |
| Annex B (informative) A-deviations..... | 20 |
| B.1 Deviations from the Netherlands | 20 |
| B.2 Deviations from Sweden | 21 |
| Bibliography | 22 |

Foreword

This document (EN 131-6:2015) has been prepared by Technical Committee CEN/TC 93 "Ladders", the secretariat of which is held by DIN.

This European Standard shall be given the status of a national standard, either by publication of an identical text or by endorsement, at the latest by September 2015, and conflicting national standards shall be withdrawn at the latest by September 2015.

Attention is drawn to the possibility that some of the elements of this document may be the subject of patent rights. CEN [and/or CENELEC] shall not be held responsible for identifying any or all such patent rights.

This document has been prepared under a mandate given to CEN by the European Commission and the European Free Trade Association.

This European Standard is one of a series about ladders. The other standards of this series are listed in Clause 2 and in the Bibliography.

According to the CEN/CENELEC Internal Regulations, the national standards organizations of the following countries are bound to implement this European Standard: Austria, Belgium, Bulgaria, Croatia, Cyprus, Czech Republic, Denmark, Estonia, Finland, Former Yugoslav Republic of Macedonia, France, Germany, Greece, Hungary, Iceland, Ireland, Italy, Latvia, Lithuania, Luxembourg, Malta, Netherlands, Norway, Poland, Portugal, Romania, Slovakia, Slovenia, Spain, Sweden, Switzerland, Turkey and the United Kingdom.

1 Scope

This European Standard specifies the general design features, requirements and test methods and defines terms for leaning and standing telescopic ladders.

Ladders with extension elements are not covered by this part of EN 131.

This part of the standard is intended to be used in conjunction with EN 131-1:2007+A1:2011, EN 131-2:2010+A1:2012, EN 131-3:2007 and if applicable EN 131-4:2007.

2 Normative references

The following documents, in whole or in part, are normatively referenced in this document and are indispensable for its application. For dated references, only the edition cited applies. For undated references, the latest edition of the referenced document (including any amendments) applies.

EN 131-1:2007+A1:2011, *Ladders - Part 1: Terms, types, functional sizes*

EN 131-2:2010+A1:2012, *Ladders - Part 2: Requirements, testing, marking*

EN 131-3:2007, *Ladders - Part 3: User Instructions*

EN 131-4:2007, *Ladders - Part 4: Single or multiple hinge-joint ladders*

3 Terms and definitions

For the purposes of this document, the terms and definitions given in EN 131-1 and the following apply.

3.1

telescopic ladder

ladder consisting of three or more rung/step sections with telescopic stiles

Note 1 to entry: Ladders with extension elements like in Figure 1 are not covered by this part of EN 131.

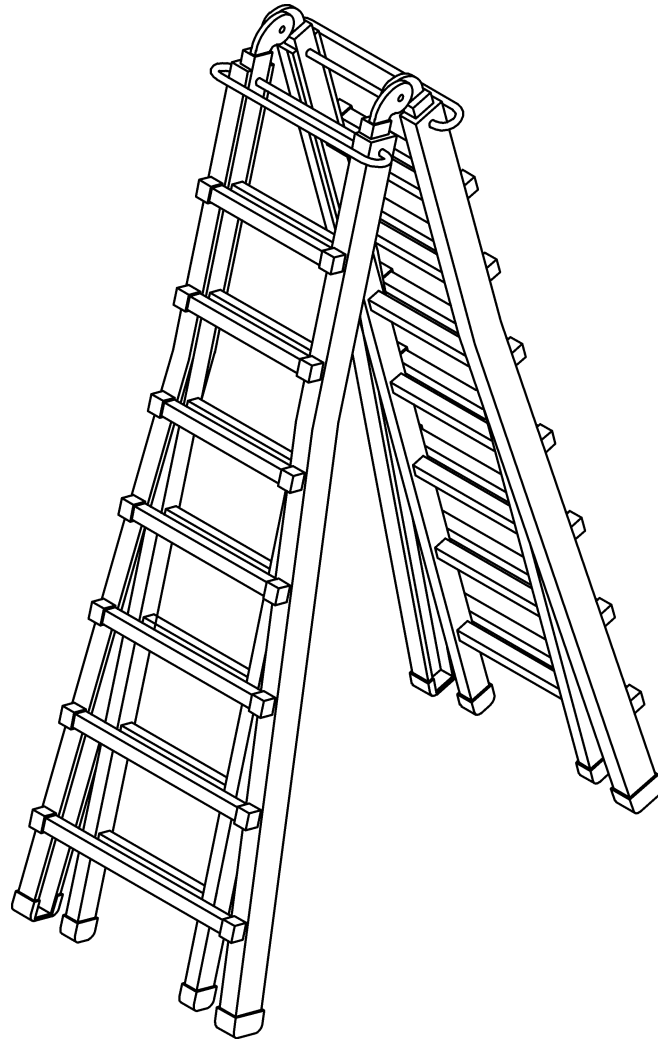

Figure 1 – Extension elements not covered by this part of EN 131

3.2

hinge-joint telescopic ladder

ladder including one or more hinge-joint devices with at least one predetermined lockable position

3.3

rung/step section

section of ladder that consists of one rung/step connected to two telescopic stiles

3.4

rung/step bracket

part that attaches the rung/step to the stile

3.5

rung/step section locking mechanism

mechanism that locks a rung/step section

3.6

locking indicator

mechanism or part that indicates that one rung/step section or part of one rung/step section is locked/unlocked

3.7

locking pin

part that locks each rung/step section and that is engaged when the locking mechanism is locked

3.8

top bar

connection between the upper parts of the two stiles where the distance between the topmost connection and the upper end of the ladder is less than, or equal to, 15 mm

Note 1 to entry: See Figure 2.

Note 2 to entry: If the distance between the end of the stiles and the upper connection of the two stiles do fulfill the requirement of l_3 , as defined in EN 131-1:2007+A1:2011, 3.37, it should be considered as a rung/step (see Figure 3).

Dimensions in millimetres

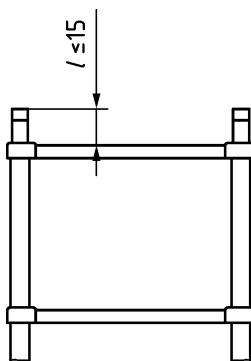

Figure 2 — Top bar

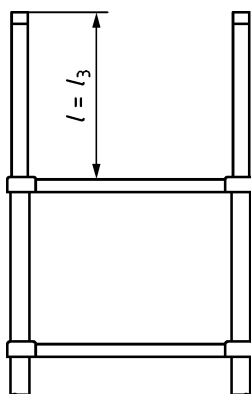

Figure 3 — Rung/step

3.9

protection against squeezing

mechanism or part that minimizes the risk of squeezing when the ladder is shortened

Note 1 to entry: For example brake system.

3.10

release function

function which releases the locking mechanism

3.11

base section

section starting from the lower end of the ladder

3.12

ascendable part

part of the ascending leg consisting only of fully extended rung/step sections

3.13

storage position

position where none of the rung/step sections are extended

4 Functional dimensions

4.1 General dimensions

Dimensions are given in EN 131-1:2007+A1:2011.

4.2 Specific dimensions

The inner width b_1 shall be measured at the upper edge of the shortest rung. The outside width b_2 shall be measured at the outside of the contact points to the ground.

l_3 shall be minimum $0,5 l_5$ and maximum $l_5 + 15$ mm measured in the middle line between the stiles.

5 Requirements

5.1 General requirements

The drawings in this part of EN 131 are examples only and products do not need to correspond. However, dimensions are binding.

For other requirements EN 131-2:2010+A1:2012, Clause 4 requirements apply.

5.2 Distance between rungs/steps

When the ladder is in use position the rungs/steps allowed to stand on shall always be equally spaced in accordance with EN 131-1:2007+A1:2011.

In the position of use the construction shall not allow different distances between the rungs/steps with a tolerance of ± 2 mm in the ascendable part of the ladder and ensure that the rung/step sections that are not extended shall be stacked on top of the ladder.

It shall not be possible for the user to alter these distances without manipulation.

5.3 Additional requirements for the top of leaning ladders

The top of the ladder has to be designed in a way that a 2-point area of contact between the top of the ladder and a vertical plane can be assured.

5.4 Locking of the rung/step sections

The ladder has to be designed in way that all extended rung/step sections are locked when the ladder is in the using position.

Every rung/step section shall have a locking mechanism for each stile. Each locking mechanism shall visibly indicate whether it is locked or unlocked.

NOTE Visible indication can for example be a coloured area or a visible locking pin.

It shall be clear if the locking mechanisms are in locked position or not when visually examining the erected ladder standing in front of the ladder holding on to it.

5.5 Design

Screws and nuts shall be secured against loosening, for example by means of self-locking or mechanically locked safety mechanisms.

It shall not be possible to separate rung/step sections without using tools.

The design shall seek to minimize the existence of shearing and squeeze points and where they do exist to minimize the shearing and squeezing effects as far as practicable.

NOTE 1 Shear or squeeze points exist if the distance between two accessible parts relative to each other is less than 25 mm and more than 7 mm in any position during movement (see EN 581-1).

The unlocking and sliding in of the ladder shall be possible in a safe way. The ladder shall be designed in a way that squeezing between the rungs/steps is avoided.

NOTE 2 Protection against squeezing can be assured by a permanent braking function of the ladder or by a special stop or distance device. If a permanent braking function is used a typical time for collapsing a section of 300 mm is 1,5 s if the movement is uniform.

If only a distance device is used for protection against squeezing between the rung/steps this device shall be located at least 80 mm from the manufacturers recommended position of the user's hands during collapse of the ladder.

6 Testing

6.1 General

For all tests, unless otherwise stated in the particular test, the following tolerances apply:

± 1 mm for longitudinal measurements;

± 5 mm for the measurement of the distance between the supports and the overhanging length;

± 1° for the measurement of angles;

± 1 % for static forces and torque.

Tests shall be performed at a temperature between 15° C and 25° C.

Where the ascendable side cannot be determined by the construction of the product, or where it is a multiple part combination ladder, the ladder shall be tested twice regarding 6.3 and 6.4. Conduct strength test and bending test on one side then rotate the ladder 180° about the longitudinal axis and repeat 6.3 and 6.4.

Inspect the ladder before testing to confirm condition and operation of all parts by fully extend the ladder.

Perform drop test according to 6.2 as preconditioning for each ladder, with the exception of test block D (bottom stile end test) and F (feet pull test), see Annex A.

6.2 Drop test

Place the extended ladder in vertical position. Let the ladder fall in the direction of use from vertical to horizontal position by its own weight. Repeat the test with ladder rotated 180° about the longitudinal axis.

Bring the ladder back to storage position.

6.3 Strength test of stiles

Extend the ladder to its maximum length. The test shall be carried out on the complete ladder. In the case of combination ladders the test shall be carried out on the complete extended ladder. Sectional ladders shall be tested at full length with all permitted pieces. The test shall be carried out without supporting legs if not permanently fixed to the ladder.

The ladder shall be placed horizontally on supports situated 200 mm from each end of the ladder.

If it is not possible to use the 200 mm distance it is allowed to reduce the distance equally at the top and the bottom.

The supports shall be cylindrical with diameters between 25 mm and 100 mm and one shall be free to rotate the other shall be fixed.

The loads shall be applied on $2/3$ of the length between the supports, measured from the support of the base section, and equally to both stiles over a width of 100 mm while it has to be taken care that an applying by jerks is avoided. The measurements shall be taken at the same point as the load has been applied.

A pre-load of 500 N shall be applied for a duration of 1 min. The position of the ladder after removal of the pre-load is the origin for measurement.

A test load F of 1100 N (see Figure 4) shall be applied for the duration of 1 min. The measurement shall be taken 1 min after removing the test load. The permanent deformation f of the ladder shall not exceed 0,1 % of the distance l between the supports.

For standing ladders, the test load F shall be determined by the formula

$$F = 2\,600\text{ N} \times \cos \alpha$$

but not less than 1000 N

where α = manufacturer's designed angle of use.

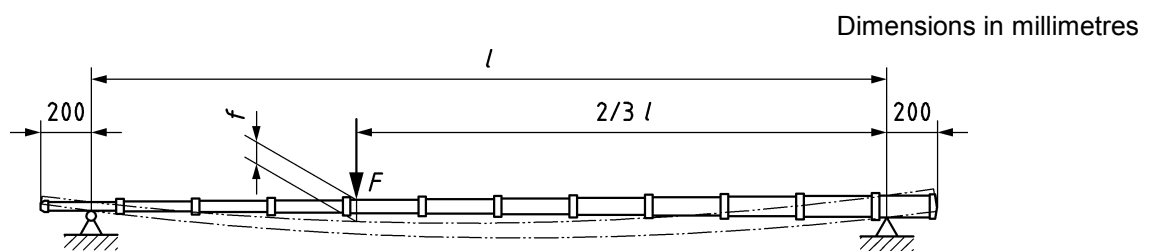

Figure 4 — Strength and bending test

6.4 Bending test of the stiles

Extend the ladder to its maximum length. The test shall be carried out on the complete ladder. In the case of combination ladders the test shall be carried out on the complete extended ladder. Sectional ladders shall be tested at full length with all permitted pieces. The test shall be carried out without supporting legs if not permanently fixed to the ladder.

The ladder shall be placed horizontally on supports situated 200 mm from each end of the ladder.

If it is not possible to use the 200 mm distance it is allowed to reduce the distance equally at the top and the bottom.

The supports shall be cylindrical with diameters between 25 mm and 100 mm and one shall be free to rotate the other shall be fixed.

The loads shall be applied on 2/3 of the length between the supports, measured from the support of the base section, and equally to both stiles over a width of 100 mm while it has to be taken care that an applying by jerks is avoided. The measurements shall be taken at the same point as the load has been applied.

A pre-load of 100 N shall be applied for the duration of 1 min. The position of the ladder with the pre-load is the origin for measurement.

A test load F of 850 N (see Figure 5) shall be applied vertically for the duration of at least 1 min.

Thereby the maximum permissible deflection f_{\max} as a function of the distance l between the supports shall be:

- $f_{\max} = 5 \times l^2 \times 10^{-6}$ mm for ladders of length less or equal to 5 m;
- $f_{\max} = 0,043 \times l - 90$ mm for ladders of length more than 5 m and less or equal to 12 m.

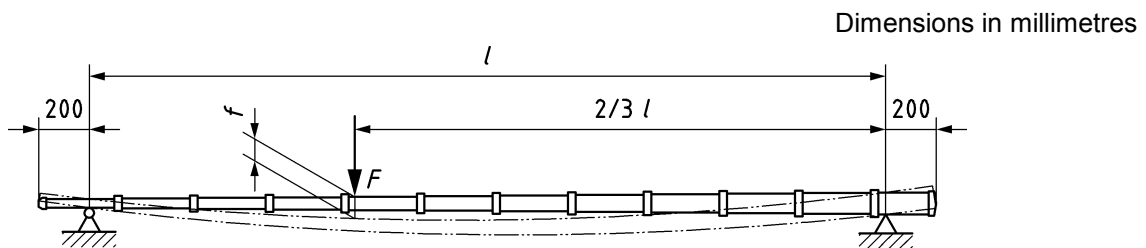

Figure 5 — Strength and bending test

6.5 Lateral deflection test of the ladder

This test shall be conducted on all one-piece ladders as well as on each ascendable part of multiple-piece ladders (standing ladders, sectional ladders and combination ladders) and on the supporting legs of standing rung- or step ladders.

The ladder shall be placed horizontally on supports situated 200 mm from each end of the ladder.

If it is not possible to use the 200 mm distance it is allowed to reduce the distance equally at the top and the bottom.

The supports shall be cylindrical with diameters between 25 mm and 100 mm and one shall be free to rotate the other shall be fixed.

The ladder shall be placed in the lateral position.

The loads shall be applied on 2/3 of the length between the supports measured from the support of the base section on the lower stile while it has to be taken care that an applying by jerks is avoided. The measurements shall be taken at the same point as the load has been applied.

A pre-load of 100 N shall be applied for the duration of 1 min. The position of the ladder with the pre-load is the origin for measurement.

A test load F of 350 N (see Figure 6) shall be applied.

The deflection is measured 1 min after loading.

Thereby the maximum permissible deflection f_{\max} as a function of the distance l between the supports shall be:

$f_{\max} = 0,005 l$, in millimetres.

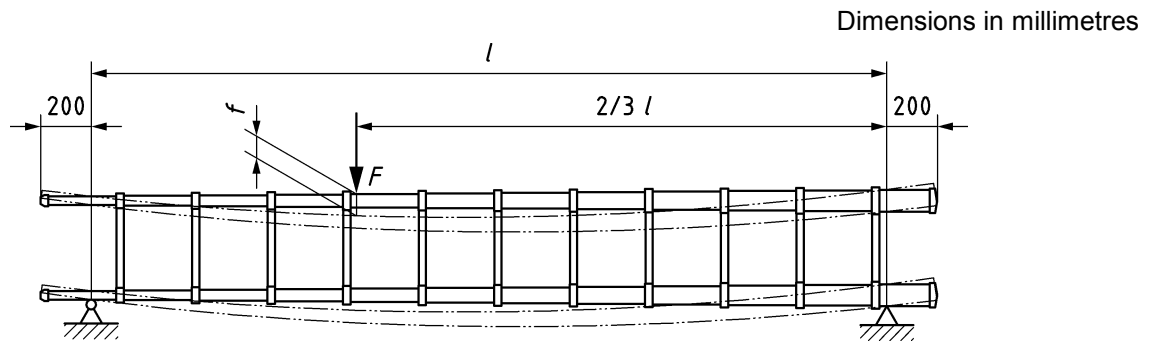

Figure 6 — Lateral deflection

6.6 Bottom stile ends test

Test according to EN 131-2:2010+A1:2012, 5.5.

6.7 Rungs/steps strength test

6.7.1 Rungs/steps strength test – locked position

Place a fully extended ladder in the maximum allowed angle according to the user instructions. Rungs/steps that can be used in two directions, e.g. hinge-joint telescopic ladders, shall be tested in both directions.

A pre-load F of 200 N shall be applied for the duration of 1 min. The position of the rung/step/platform after removal of the pre-load is the origin for measurement.

In the position of use of the ladder a test load F of 2 600 N (see Figure 7) shall be applied vertically on the midpoint of the weakest rung/step of any design evenly distributed over a width of 100 mm and a depth equal to the rung/step and for the duration of 1 min.

The maximum permanent deformation after removal of the test load shall be less than or equal to 0,5 % of the length of the tested rung/step, measured underneath the tested rung/step.

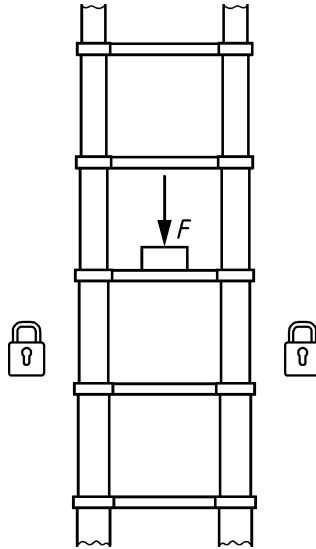

Figure 7 — Rungs/steps strength test – locked position

6.7.2 Rungs/steps strength test – unlocked position

Place the fully extended ladder in the maximum allowed angle according to the user instructions. Rungs/steps that can be used in two directions, e.g. hinge joint ladders, shall be tested in both directions.

A vertical test load F of 2600 N shall be applied for the duration of 1 min on the upper most rung/step section allowed to be used according to the user manual as close as possible to the stile over a width of 100 mm while it has to be taken care that an applying by jerks is avoided (see Figure 8).

Before applying the load, unlock the rung/step locking mechanism of this rung/step section on the same side where the load is applied.

After the load has been removed the ladder shall be put in storage position. Extend the ladder again.

Requirements:

- no rupturing of parts shall be observed;
- the release function and/or locking indicator shall work correctly;
- the locking mechanism shall work correctly;
- there shall be no relative movement between the brackets and the rungs/steps;
- permanent deformation is only acceptable providing the ladder remains fully functional and it does not impair the fitness for use, or safety, of the ladder.

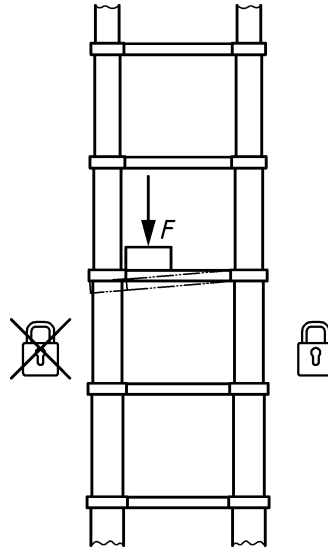

Figure 8 — Rungs/steps strength test – unlocked position

6.7.3 Torsion test of rungs/steps

Test according to EN 131-2:2010+A1:2012, 5.7.

6.7.4 Pull out test of rung/step

The fastening of the rung/step shall be tested on a fully extended ladder. The test shall be executed in the longitudinal direction of the rung/step with a gradually increasing pull out load F up to at least 2 600 N (see Figure 9). The load shall be applied on the stiles as close as possible to the rung/step which is as close as possible to the middle of the ladder. The load F shall be equally divided to both sides of that rung/step. After the test the telescopic ladder and the locking mechanism have to function in all sections.

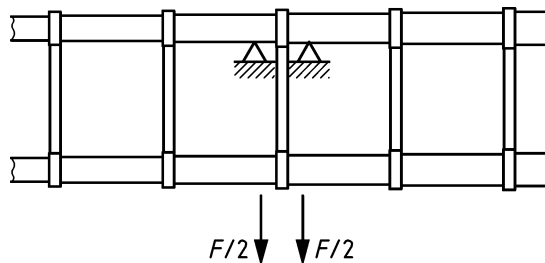

Figure 9 — Pull out test of rung/step

6.8 Test of opening restraints and hinges of standing ladders

Extend the ladder to its maximum length.

Each leg of the ladder in the working position is placed on a platform provided with multidirectional rollers (see Figure 10). The effects of friction, from both the rollers and floor surface, shall be negligible. The test has to be conducted on a clean, smooth finish concrete floor.

After removal of the test loads no visible permanent deformation shall occur on the hinge joints and opening restraints. The ladder shall not show any visible damage such as cracks, indentations etc. Permanent deformation is only acceptable providing the ladder remains fully functional and it does not impair the fitness for use, or safety, of the ladder.

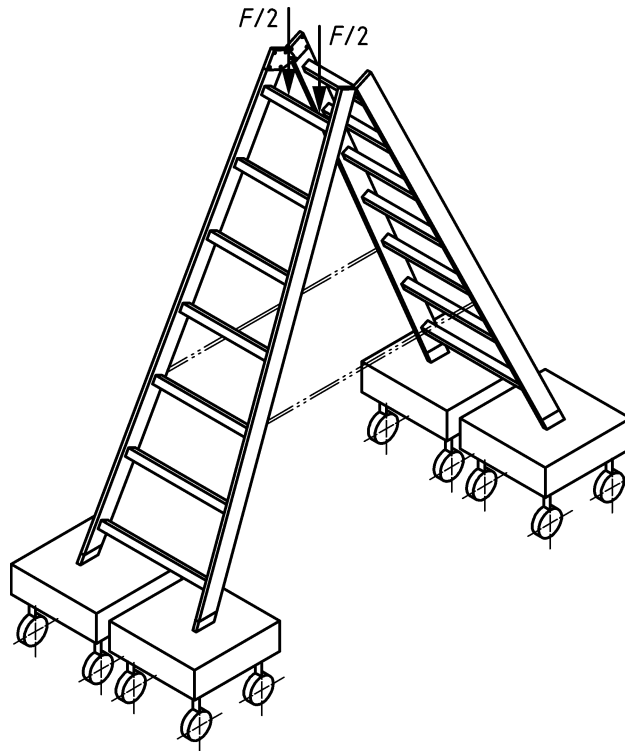

Figure 10 — Test of opening restraint devices and hinges of standing ladders

The test load F of 2 600 N is divided into two loads of 1 300 N (see Figure 10), distributed over two plates each 100 mm long with a width at least equal to the surface of the rung or step, but not longer than 100 mm. It has to be applied to the uppermost rung or step as close as possible to the stiles for the duration of 1 min. This test is then repeated on the other leg.

6.9 Test of locking mechanism

6.9.1 Cyclic test of locking mechanism

Aim of the test is to check the functional reliability of the locking mechanism and the protection system against squeezing for a longer time. The most unfavourable ladder section shall be tested. Test shall be carried out vertically. The ladder will stand in a holdfast during the test.

The following test cycle shall be conducted:

1. unlocking of the rung (if needed);
2. pulling out of the rung section as far as possible till it locks automatically;
3. apply a vertical load of 750 N on each stile for the duration of 3 s to 5 s;
4. after removing the load the release function shall be operated;
5. bring the ladder section in by its own weight. If not possible it has to be forced down.

During movement the rung/step section locking mechanism and/or release function shall not be operated or operated as less as practicable.

This cycle shall be repeated for 4 000 times. The frequency of the cycles shall be elected in a way that the dynamic forces and the heating during the cycle of the test sample are minimized.

Requirements:

- the rung/step locking mechanism has to work in a proper way during and after the test;
- the complete ladder shall be fit for use after the test;
- the protection system against squeezing shall work in a correct way;
- if there is visible damage on a rung after the cyclic test, test 6.7.1 (rungs/steps strength test – locked position) shall be performed again on that rung.

No lubricants shall be added before, or during, the test.

6.9.2 Static test of locking mechanism

The ladder shall be extended to its complete length.

A test load F of 3 500 N (see Figure 11) shall be applied at the upper part of one stile of the ladder, in the direction of the length of the ladder for the duration of 1 min.

After removal of the test load, permanent deformation is only acceptable providing the ladder remains fully functional and it does not impair the fitness for use, or safety, of the ladder.

Repeat for the other stile.



Figure 11 — Test for locking mechanisms

6.9.3 Cyclic test of hinge joints

For hinge-joint telescopic ladders additional tests for the hinges shall be performed according to EN 131-4:2007, 6.2.3.

6.9.4 Requirements

After the tests in 6.9.1 to 6.9.3, the following shall be fulfilled:

- no rupturing of parts shall be observed;
- the release function and/or locking indicator shall work correctly;
- the locking mechanism shall work;
- there shall be no relative movement between the brackets and the rungs/steps.

Permanent deformation or wear is only acceptable providing the ladder remains fully functional and it does not impair the fitness for use, or safety, of the ladder.

6.10 Feet pull test

Test according to EN 131-2:2010+A1:2012, 5.11.

6.11 Torsion on ladder length

The ladder shall be fully extended and tested in its full length. The ladder shall be placed horizontally on supports situated 200 mm from each end of the ladder. The ladder shall be fixed to the support at the base section. The top end shall be free to move (see Figure 12).

If it is not possible to use the 200 mm distance it is allowed to reduce the distance equally at the top and the bottom.

A static load W of 630 N shall be applied at the rung which is nearest to 1/3 of the length between the supports, measured from the support of the base section. The load W shall be applied as close as possible to the stile.

A test load F shall be applied on 2/3 of the length between the supports, measured from the support of the base section. The axis of rotation is the length axis of the ladder, which is also defined as the point of reference for the test torque. The lever arm, with the maximum weight of 2,5 kg, shall be rested at both stiles whereas only one side is fixed at the stile. The datum of the inclination of the lever arm shall be measured before it is loaded. After that the test load F of 260 N shall be applied at 500 mm from the length axis of the ladder (see dimension a in Figure 12) without any jerks.

The test load shall be applied for the duration of 1 min. At the end of the minute the angle of the lever arm, excluding the initial inclination, shall be recorded. The test shall be conducted only in one direction at symmetric stiles. If the ladder has unsymmetrical stiles the test shall be conducted in both directions.

Requirement: Maximum torsion angle under application of the test load shall be $\leq 9^\circ$.

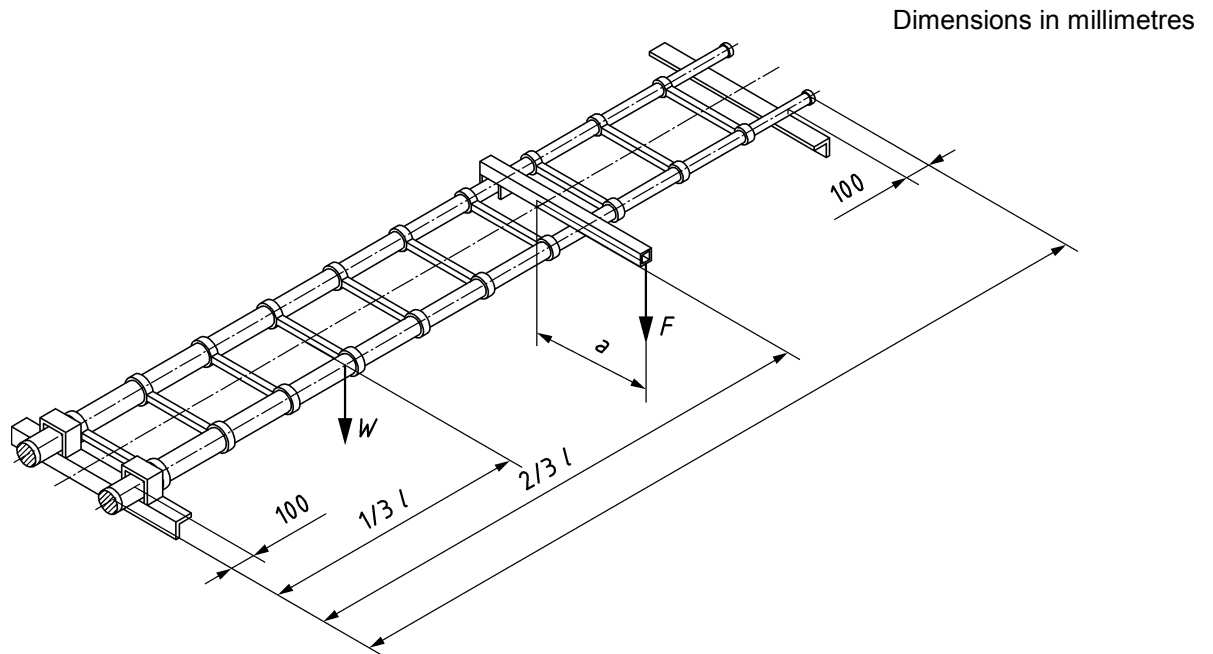

Figure 12 — Torsion test

6.12 Test methods for plastic ladders

Test methods for plastic ladders shall be tested in accordance with EN 131-2:2010+A1:2012, 5.16.

6.13 Test methods for plastic rung/step brackets

If a rung/step bracket consists of plastic material EN 131-2:2010+A1:2012, 5.16.2.2 is applicable.

7 Marking and User Instruction

7.1 General

Marking and user instruction shall be durable. The durability shall be checked by inspection and by rubbing the marking/user instruction lightly:

- first for 15 s with a cloth soaked in water;
- then for 15 s with a cloth soaked in petroleum spirit, e.g. n-Hexan.

There shall be no reduction of legibility at the conclusion of the test. Adhesive labels, where used, shall not have worked loose or become curled at the edges.

7.2 Marking

Only telescopic ladders that are in compliance with EN 131-6 may be marked "EN 131".

The way of indicating the locked or unlocked condition of the locking mechanisms shall be explained on the ladder and in the manual.

The handling of the locking/unlocking function shall be explained on the ladder.

It shall be explained on the ladder that in the leaning ladder position it is not allowed to climb on the last metre from the top of the ladder.

It shall be explained on the ladder where the user shall put the hands when bringing the ladder from extended to storage position.

7.3 User instruction

It shall be stated in the user instruction:

- that in the leaning ladder position it is not allowed to climb higher than last metre of the ladder;
- that the locking mechanisms for all the extended rung/step sections shall be locked before using the ladder;
- that the ladder shall be inspected after delivery and before every use to confirm condition and operation of all parts;
- that before using the ladder it shall be checked that all locking mechanisms are working properly. If the mechanism is not working properly, do not use the ladder;
- where the user shall put the hands when bringing the ladder from extended to storage position.

User instructions not covered by the above have to be in accordance with EN 131-3.

Annex A (normative) Test sequence

The test sequence is given in Table A.1. Test blocks may be performed in serial or parallel order. Tests performed within one block shall be performed on the same ladder.

Table A.1 — Test sequence

| Test block | Kind of test | Leaning ladder | Standing ladder |
|----------------------------|--|----------------|-----------------|
| A1 | 6.2 Drop test | X | X |
| A2 | 6.3 Strength test of the stiles | X | X |
| A3 | 6.4 Bending test of the stiles | X | X |
| A4 | 6.5 Lateral deflection test of the ladder | X | X |
| A5 | 6.11 Torsion on ladder length | X | X |
| B1 | 6.7.1 Rungs/steps strength test – locked position | X | X |
| B2 | 6.7.2 Rungs/steps strength test – unlocked position | X | X |
| B3 | 6.7.3 Torsion test of rungs/steps | X | X |
| B4 | 6.7.4 Pull out test of rung/step | X | X |
| C1 | 6.9.1 Cyclic test of locking mechanism | X | X |
| C2 | 6.9.2 Static test of locking mechanism | X | X |
| C3 ^a | 6.7.1 Rungs/steps strength test – locked position | X | X |
| D | 6.6 Bottom stile ends test | X | X |
| E | 6.8 Test of opening restraints and hinges of standing ladders | – | X |
| F | 6.10 Feet pull test | X | X |
| G | 6.9.3 Cyclic test of hinge joints | X | X |
| ^a If applicable | | | |

Annex B (informative)

A-deviations

A-deviation: National deviation due to regulations, the alteration of which is for the time being outside the competence of the CEN-CENELEC national member.

This European Standard does not fall under any Directive of the EU.

In the relevant CEN-CENELEC countries these A-deviations are valid instead of the provisions of the European Standard until they have been removed.

B.1 Deviations from the Netherlands

A-deviation in order to reflect the Dutch legal requirement regarding the following points:

- A. Strength test of leaning ladder (EN 131-2:2010+A1:2012, 5.2)
- B. Test on handrails (scope EN 131-1, scope EN 131-2 and EN 131-2:2010+A1:2012, 5.12)
- C. Torsion on ladder length (EN 131-2:2010+A1:2012, 5.15)

The test under A replaces the test 5.2 from EN 131-2:2010+A1:2012 and test 6.2.2 from EN 131-4:2007 and test 6.3 from EN 131-6. The requirements under point B and points C are additional.

In the Netherlands all ladders and step ladders for both the consumer market and the professional market have to fulfil the requirements of the Besluit Draagbaar Klimmaterieel (law on portable climbing equipment), which is part of the Dutch "Warenwet" (law for goods).

On top of that products for the professional market have to fulfill the requirements of the NEN 2484 as is mentioned in the "Arbobeleidsregels", that are part of the Dutch Arboret (law for labour conditions).

Concerning point A. we refer to the 'Besluit Draagbaar Klimmaterieel', appendix B, point 2 and 3 (see Annex 1) in which clearly is stated that we have to test all ladders and stepladders in position of use with a force of 3 500 N. This means that they are suitable for a workload of 100 kg. This is in contradiction with the scopes of EN 131-1 and EN 131-2 and 5.2 of EN 131-2:2010+A1:2012.

Concerning point B. we refer to the 'Besluit Draagbaar Klimmaterieel', appendix A, article 3' (see Annex 2), in which is mentioned that for all platforms on ladders you need a handrail of at least 60 cm high. This is in contradiction with EN 131-2:2010+A1:2012, 5.12 where is stated that only when there is a handrail you have to do this test while in 'Besluit Draagbaar Klimmaterieel' is mentioned that all stepladders should have a handrail and fulfil this test.

Concerning point C we refer to the 'NEN 2484' which is mentioned in 'de beleidsregel 7.4-4' which is part of the Dutch Arboret (see annex 3) and is part of the legislation as is written in the letter of 2003-03-25 (Arbeidsinspectie, Ministerie SZW, see annex 4). In par. 6.2.3 and 7.2.3 of the NEN 2484 (see annex 5) a torsion test is mentioned which is fundamentally different from the torsion test on ladder length as mentioned in EN 131-2:2010+A1:2012, 5.15 because the whole ladder is tested in the NEN 2484 instead of just a part of the ladder.

Point A:

As preparation the tests under a and/or b shall be done with a load of 1 000 N (preload). As second preparation repeat the first preparation with a 10 mm thick block under one beam and do this again until all beams have been on the block.

a) Position products that can be used in leaning position maximally extended at an angle of 75° on a horizontal surface against a sufficiently strong vertical surface.

Put a load of 3 500 N in the middle of the rung or step closest to the middle of the beams. The load shall be divided over a surface of 90 mm and the step or rung depth.

b) Position products that can be used free standing in maximally opened position on a sufficiently strong horizontal surface. Apply the load described under a) on the step or rung closest to the middle and, if applicable, on the platform.

c) After taking away the load, there shall be no permanent deflection, with the exception of beams of aluminium, where a deflection of maximally 1/1 000 of the length is allowed. This is for both the test under a) and the test under b). In the case of free standing products the length of beams shall be interpreted as the distance between the foot and the hinge point of the beams.

The tests mentioned above are based on a user load of 100 kg (including clothing and eventual tools), for ladders to be used with more than 100 kg load, relevant additional requirements shall be fulfilled.

Products that can be used in leaning position as well as in freestanding position have to be tested in both positions. Products that can be climbed from more than one side shall be tested on all accessible sides.

Point B:

If a ladder is equipped with a platform, it shall be equipped with a guardrail with its top at least 600 mm vertical above the platform. The vertical projection of the supporting side of this guardrail shall not be in front of or behind the platform.

Point C:

Support the product in horizontal position at the top side under both beams and at the bottom side under 1 beam, all at 200 mm from the beam end. Products consisting of more than one part shall be extended to the maximum. Apply a vertical load of 100 N at the centre of the product during 60 s (if necessary using a bar between the two beams). This is the preload; after removing this load the zero position has to be determined. Repeat the loading with 250 N during at least 600 s. After removing this load the difference in vertical deflection between the beams shall be less than or equal to 0,07 times the outer width of the ladder at that height.

B.2 Deviations from Sweden

According to the Swedish Work Environment Act and AFS 2004:3 the following is required in Sweden:

For curved rungs the radius shall be greater than or equal to 30 mm and ladders with round rungs are not allowed (see 4.1, refer also to EN 131-2).

Freestanding ladders and other ladders with a knee rail up to 1,8 m standing height shall be equipped with a closing restraint device to prevent the legs of the ladder come together (see 5.5, refer also to EN 131-2).

The inner width, b1, for all types of ladders shall be minimum 300 mm. For leaning ladders, the outside width, b2, shall be minimum 400 mm (see 4.1, refer also to EN 131-1).

Bibliography

- [1] EN 131-7, *Ladders - Part 7: Mobile ladders with platform*
- [2] EN 581-1, *Outdoor furniture - Seating and tables for camping, domestic and contract use - Part 1: General safety requirements*
- [3] EN 1147, *Portable ladders for fire service use*
- [4] EN 10088-2, *Stainless steels - Part 2: Technical delivery conditions for sheet/plate and strip of corrosion resisting steels for general purposes*
- [5] EN 14183, *Step stools*
- [6] EN 61478, *Live working - Ladders of insulating material (IEC 61478)*
- [7] EN ISO 472:2013, *Plastics - Vocabulary (ISO 472:2013)*

British Standards Institution (BSI)

BSI is the national body responsible for preparing British Standards and other standards-related publications, information and services.

BSI is incorporated by Royal Charter. British Standards and other standardization products are published by BSI Standards Limited.

About us

We bring together business, industry, government, consumers, innovators and others to shape their combined experience and expertise into standards-based solutions.

The knowledge embodied in our standards has been carefully assembled in a dependable format and refined through our open consultation process. Organizations of all sizes and across all sectors choose standards to help them achieve their goals.

Information on standards

We can provide you with the knowledge that your organization needs to succeed. Find out more about British Standards by visiting our website at bsigroup.com/standards or contacting our Customer Services team or Knowledge Centre.

Buying standards

You can buy and download PDF versions of BSI publications, including British and adopted European and international standards, through our website at bsigroup.com/shop, where hard copies can also be purchased.

If you need international and foreign standards from other Standards Development Organizations, hard copies can be ordered from our Customer Services team.

Subscriptions

Our range of subscription services are designed to make using standards easier for you. For further information on our subscription products go to bsigroup.com/subscriptions.

With **British Standards Online (BSOL)** you'll have instant access to over 55,000 British and adopted European and international standards from your desktop. It's available 24/7 and is refreshed daily so you'll always be up to date.

You can keep in touch with standards developments and receive substantial discounts on the purchase price of standards, both in single copy and subscription format, by becoming a **BSI Subscribing Member**.

PLUS is an updating service exclusive to BSI Subscribing Members. You will automatically receive the latest hard copy of your standards when they're revised or replaced.

To find out more about becoming a BSI Subscribing Member and the benefits of membership, please visit bsigroup.com/shop.

With a **Multi-User Network Licence (MUNL)** you are able to host standards publications on your intranet. Licences can cover as few or as many users as you wish. With updates supplied as soon as they're available, you can be sure your documentation is current. For further information, email bsmusales@bsigroup.com.

BSI Group Headquarters

389 Chiswick High Road London W4 4AL UK

Revisions

Our British Standards and other publications are updated by amendment or revision.

We continually improve the quality of our products and services to benefit your business. If you find an inaccuracy or ambiguity within a British Standard or other BSI publication please inform the Knowledge Centre.

Copyright

All the data, software and documentation set out in all British Standards and other BSI publications are the property of and copyrighted by BSI, or some person or entity that owns copyright in the information used (such as the international standardization bodies) and has formally licensed such information to BSI for commercial publication and use. Except as permitted under the Copyright, Designs and Patents Act 1988 no extract may be reproduced, stored in a retrieval system or transmitted in any form or by any means – electronic, photocopying, recording or otherwise – without prior written permission from BSI. Details and advice can be obtained from the Copyright & Licensing Department.

Useful Contacts:

Customer Services

Tel: +44 845 086 9001

Email (orders): orders@bsigroup.com

Email (enquiries): cservices@bsigroup.com

Subscriptions

Tel: +44 845 086 9001

Email: subscriptions@bsigroup.com

Knowledge Centre

Tel: +44 20 8996 7004

Email: knowledgecentre@bsigroup.com

Copyright & Licensing

Tel: +44 20 8996 7070

Email: copyright@bsigroup.com



...making excellence a habit.™