



BSI Standards Publication

Gully tops and manhole tops for vehicular and pedestrian areas

Part 1: Definitions, classification, general principles of design, performance requirements and test methods

National foreword

This British Standard is the UK implementation of EN 124-1:2015. Together with BS EN 124-2:2015, BS EN 124-3:2015, BS EN 124-4:2015, BS EN 124-5:2015 and BS EN 124-6:2015, it supersedes BS EN 124:1994 which is withdrawn.

BSI, as a member of CEN, is obliged to publish EN 124-1 as a British Standard. However, attention is drawn to the fact that during the development of this European Standard, the UK committee voted against its approval as a European Standard.

The technical reasoning behind the response relates to three specific areas:

1. Subclause 7.4.2 specifies three alternative sets of requirements to provide adequate skid resistance. The UK committee expresses concern that there is no research available to validate the equivalence or adequacy of these requirements.
2. The pull-out tests as described in Annex E are not representative of in-service conditions and are not supported by any evidence of safe behaviour in service, taking no account of the forces that may generate cover movement and/or displacement. Consequently the requirements of subclause 6.6 and the test method in Annex E may not guarantee or provide guidance to users and specifiers for the durability and safe behaviour of manhole tops and gully tops in service.
3. The load tests described in subclause A.4.2 do not take into account the load bearing capacity of individual or multiple cover elements at test locations other than the prescribed centralized test locations and the subsequent effects on performance and durability of the installation. Readers of this standard may find it useful to refer to BS 7903, *Guide to selection and use of gully tops and manhole covers for installation within the highway*.

Users may wish to consider these issues when specifying products.

The UK participation in its preparation was entrusted by Technical Committee B/505, Wastewater engineering, to Subcommittee B/505/4, "Manhole Covers, Surface Boxes And Other Road Fittings".

A list of organizations represented on this subcommittee can be obtained on request to its secretary.

This publication does not purport to include all the necessary provisions of a contract. Users are responsible for its correct application.

© The British Standards Institution 2015.
Published by BSI Standards Limited 2015

ISBN 978 0 580 79318 9

ICS 93.080.30

Compliance with a British Standard cannot confer immunity from legal obligations.

This British Standard was published under the authority of the Standards Policy and Strategy Committee on 31 July 2015.

Amendments/corrigenda issued since publication

Date	Text affected
------	---------------

English Version

Gully tops and manhole tops for vehicular and pedestrian areas - Part 1: Definitions, classification, general principles of design, performance requirements and test methods

Dispositifs de couronnement et de fermeture pour les zones de circulation utilisées par les piétons et les véhicules -
Partie 1 : Définitions, classification, principes généraux de conception, exigences de performances et méthodes d'essai

Aufsätze und Abdeckungen für Verkehrsflächen - Teil 1:
Definitionen, Klassifizierung, allgemeine Baugrundsätze, Leistungsanforderungen und Prüfverfahren

This European Standard was approved by CEN on 12 March 2015.

CEN members are bound to comply with the CEN/CENELEC Internal Regulations which stipulate the conditions for giving this European Standard the status of a national standard without any alteration. Up-to-date lists and bibliographical references concerning such national standards may be obtained on application to the CEN-CENELEC Management Centre or to any CEN member.

This European Standard exists in three official versions (English, French, German). A version in any other language made by translation under the responsibility of a CEN member into its own language and notified to the CEN-CENELEC Management Centre has the same status as the official versions.

CEN members are the national standards bodies of Austria, Belgium, Bulgaria, Croatia, Cyprus, Czech Republic, Denmark, Estonia, Finland, Former Yugoslav Republic of Macedonia, France, Germany, Greece, Hungary, Iceland, Ireland, Italy, Latvia, Lithuania, Luxembourg, Malta, Netherlands, Norway, Poland, Portugal, Romania, Slovakia, Slovenia, Spain, Sweden, Switzerland, Turkey and United Kingdom.



EUROPEAN COMMITTEE FOR STANDARDIZATION
COMITÉ EUROPÉEN DE NORMALISATION
EUROPÄISCHES KOMITEE FÜR NORMUNG

CEN-CENELEC Management Centre: Avenue Marnix 17, B-1000 Brussels

Contents

Page

Foreword.....	4
1 Scope	6
2 Normative references	6
3 Terms and definitions, symbols, units and abbreviated terms	7
3.1 Terms and definitions	7
3.2 Symbols and abbreviated terms	11
4 Classification.....	11
4.1 Basis of the classification.....	11
4.2 Classification in the context of intended use	11
5 Materials	13
5.1 General.....	13
5.2 Cover fillings	13
5.3 Frames in combination with concrete	13
6 Design requirements	13
6.1 Vents in covers	13
6.2 Clear opening of manhole tops for man entry	14
6.3 Depth of insertion	14
6.4 Clearance.....	14
6.5 Compatibility of seatings	15
6.6 Securing of the cover/grating within the frame	15
6.7 Handling of covers and gratings.....	16
6.8 Slot dimensions of gratings	16
6.9 Dirt pans and dirt buckets	17
6.10 Positioning of covers and gratings.....	18
6.11 Flatness of manhole covers and gratings.....	18
6.12 Concaveness of gratings	18
6.13 Surface conditions.....	18
6.14 Manhole tops with sealing features	18
6.15 Frame bearing area.....	18
6.16 Frame depth	18
6.17 Opening angle of hinged covers/gratings.....	19
6.18 Covers with fillings.....	19
7 Performance requirements	19
7.1 Appearance	19
7.2 Load bearing capacity.....	19
7.3 Permanent set.....	19
7.4 Skid resistance.....	20
7.5 Child safety.....	21
8 Testing	22
8.1 General.....	22
8.2 Permanent set (see 7.3).....	22
8.3 Load bearing capacity (see 7.2)	22
8.4 Verification of design requirements	22
8.5 Child safety.....	24
9 Assessment and verification of constancy of performance (AVCP).....	24

Annex A (normative) Permanent set test	25
A.1 Test Samples	25
A.2 Permanent set test load, (F_P)	25
A.3 Apparatus	25
A.4 Procedure	26
Annex B (normative) Test of load bearing capacity	29
B.1 Test samples	29
B.2 Test load (F_T)	29
B.3 Test procedure	29
B.4 Test report	29
Annex C (normative) Test to determine the unpolished skid resistance value (USRV) of manhole covers	30
C.1 General	30
C.2 Apparatus	30
C.3 Calibration of pendulum friction test equipment	30
C.4 Selection of test samples	30
C.5 Test procedure	30
Annex D (normative) Tilt test	33
D.1 General	33
D.2 Test procedure	33
Annex E (normative) Testing of securing of covers/gratings within the frame	36
E.1 General	36
E.2 Vertical pull-out test procedure	37
Annex F (informative) Recommendations for installation	41
F.1 General	41
F.2 Place of installation and selection of appropriate manhole tops and gully tops	41
F.3 Preparations before installation	41
F.4 Operative skill, training and installation equipment	41
F.5 Bedding and packing materials	42
F.6 Condition of supporting chamber	42
F.7 Fixing of manhole tops or gully tops	42
F.8 Post installation check and cleaning	42
Annex G (informative) Explanations on testing of manhole tops with multiple covers and testing the skid resistance	44
G.1 Explanation to A.4	44
G.2 Explanation to 7.4.2	44
Bibliography	45

Foreword

This document (EN 124-1:2015) has been prepared by Technical Committee CEN/TC 165 "Wastewater engineering", the secretariat of which is held by DIN.

This European Standard shall be given the status of a national standard, either by publication of an identical text or by endorsement, at the latest by December 2015 and conflicting national standards shall be withdrawn at the latest by March 2017.

Attention is drawn to the possibility that some of the elements of this document may be the subject of patent rights. CEN [and/or CENELEC] shall not be held responsible for identifying any or all such patent rights.

Together with EN 124-2:2015, EN 124-3:2015, EN 124-4:2015, EN 124-5:2015 and EN 124-6:2015, this document supersedes EN 124:1994.

This document has been prepared under a mandate given to CEN by the European Commission and the European Free Trade Association.

EN 124, *Gully tops and manhole tops for vehicular and pedestrian areas*, consists of the following parts:

- *Part 1: Definitions, classification, general principles of design, performance requirements and test methods;*
- *Part 2: Gully tops and manhole tops made of cast iron;*
- *Part 3: Gully tops and manhole tops made of steel or aluminium alloys;*
- *Part 4: Gully tops and manhole tops made of steel reinforced concrete;*
- *Part 5: Gully tops and manhole tops made of composite materials;*
- *Part 6: Gully tops and manhole tops made of polypropylene (PP), polyethylene (PE) or unplasticized poly(vinyl chloride) (PVC-U).*

EN 124-1 is not a harmonized standard but a supporting standard for the harmonized standards EN 124-2, EN 124-3, EN 124-4, EN 124-5 and EN 124-6.

The main changes with respect to the previous edition are listed below:

- a) the standard was split into 6 parts, where Part 1 contains general design and performance requirements and Parts 2 to 6 performance requirements for manhole tops and gully tops made of specific materials;
- b) definition for "securing feature" added;
- c) definition for "locking accessory" added;
- d) skid resistance test added;
- e) tilt test added;
- f) test of securing of covers/gratings within the frame added;
- g) evaluation of conformity changed to AVCP;
- h) recommendations for installation added.

According to the CEN-CENELEC Internal Regulations, the national standards organizations of the following countries are bound to implement this European Standard: Austria, Belgium, Bulgaria, Croatia, Cyprus, Czech Republic, Denmark, Estonia, Finland, Former Yugoslav Republic of Macedonia, France, Germany, Greece, Hungary, Iceland, Ireland, Italy, Latvia, Lithuania, Luxembourg, Malta, Netherlands, Norway, Poland, Portugal, Romania, Slovakia, Slovenia, Spain, Sweden, Switzerland, Turkey and the United Kingdom.

1 Scope

This European Standard is applicable to manhole tops and gully tops with a clear opening up to and including 1 000 mm for covering gullies, manholes and inspection chambers installed in areas subjected to pedestrian and/or vehicular traffic. It specifies definitions, classification, general principles of design, performance requirements and test methods for gully tops and manhole tops according to:

- EN 124-2, for gully tops and manhole tops made of cast iron;
- EN 124-3, for gully tops and manhole tops made of steel or aluminium alloys;
- EN 124-4, for gully tops and manhole tops made of steel reinforced concrete;
- EN 124-5, for gully tops and manhole tops made of composite materials;
- EN 124-6, for gully tops and manhole tops made of polypropylene (PP), polyethylene (PE) or unplasticized poly(vinyl chloride) (PVC-U).

Part 1 is only applicable in combination with at least one of the standards EN 124-2, EN 124-3, EN 124-4, EN 124-5 and EN 124-6 each of which has this Part 1 as an integral part.

This European Standard is not applicable to:

- gratings/covers as part of prefabricated drainage channels according to EN 1433,
- floor and roof gullies in buildings which are specified in EN 1253 (all parts),
- surface boxes.

2 Normative references

The following documents, in whole or in part, are normatively referenced in this document and are indispensable for its application. For dated references, only the edition cited applies. For undated references, the latest edition of the referenced document (including any amendments) applies.

EN 124-2:2015, *Gully tops and manhole tops for vehicular and pedestrian areas — Part 2: Gully tops and manhole tops made of cast iron*

EN 124-3:2015, *Gully tops and manhole tops for vehicular and pedestrian areas — Part 3: Gully tops and manhole tops made of steel or aluminium alloys*

EN 124-4:2015, *Gully tops and manhole tops for vehicular and pedestrian areas — Part 4: Gully tops and manhole tops made of steel reinforced concrete*

EN 124-5:2015, *Gully tops and manhole tops for vehicular and pedestrian areas — Part 5: Gully tops and manhole tops made of composite materials*

EN 124-6:2015, *Gully tops and manhole tops for vehicular and pedestrian areas — Part 6: Gully tops and manhole tops made of polypropylene (PP), polyethylene (PE) or unplasticized poly(vinyl chloride) (PVC-U)*

EN 206:2013, *Concrete — Specification, performance, production and conformity*

EN 13036-4, *Road and airfield surface characteristics — Test methods — Part 4: Method for measurement of slip/skid resistance of a surface: The pendulum test*

EN ISO 868, *Plastics and ebonite — Determination of indentation hardness by means of a durometer (Shore hardness) (ISO 868)*

EN ISO 7500-1:2004, *Metallic materials — Verification of static uniaxial testing machines — Part 1: Tension/compression testing machines — Verification and calibration of the force-measuring system (ISO 7500-1:2004)*

3 Terms and definitions, symbols, units and abbreviated terms

For the purposes of this document, the following terms and definitions apply.

3.1 Terms and definitions

3.1.1

manhole

structure with a removable cover constructed on a drain or sewer to permit entry by personnel

[SOURCE: EN 16323:2014, 2.2.4.15]

3.1.2

inspection chamber

structure with a removable cover constructed on a drain or sewer that permits the introduction of cleaning and inspection equipment from surface level, but does not provide access for personnel

[SOURCE: EN 16323:2014, 2.2.4.13]

3.1.3

gully

assembly to receive water for discharge into a drainage system

3.1.4

gully top

upper part of a gully consisting of a frame and grating with or without cover

3.1.5

manhole top

upper part of a manhole or inspection chamber consisting of a frame and cover and/or grating

3.1.6

frame

part of a gully top or manhole top which receives and supports a grating and/or a cover

3.1.7

frame depth

distance between the top surface and the bottom surface of the frame

3.1.8

grating

movable part(s) or opening within a manhole top or a gully top which permit(s) the passage of water through itself into the gully or manhole

3.1.9

cover

movable part(s) of a manhole top or a gully top which covers the manhole or gully opening

**3.1.10
element**

frame or cover or grating of a manhole top or gully top

Note 1 to entry: Hinges, locking accessories and other accessories are not elements.

**3.1.11
vent**

opening in the cover of a manhole top to provide ventilation

**3.1.12
dirt bucket**

removable component of a gully top which collects debris

**3.1.13
dirt pan**

removable component of manhole top which collects debris

**3.1.14
seating**

surface on which the grating or the cover rests in the frame

**3.1.15
depth of insertion**

A
distance between the top of the frame and the bottom of the cover or grating adjacent to the seating

Note 1 to entry: Examples are given in Figure 1. The depth of insertion is expressed in millimetres (mm).

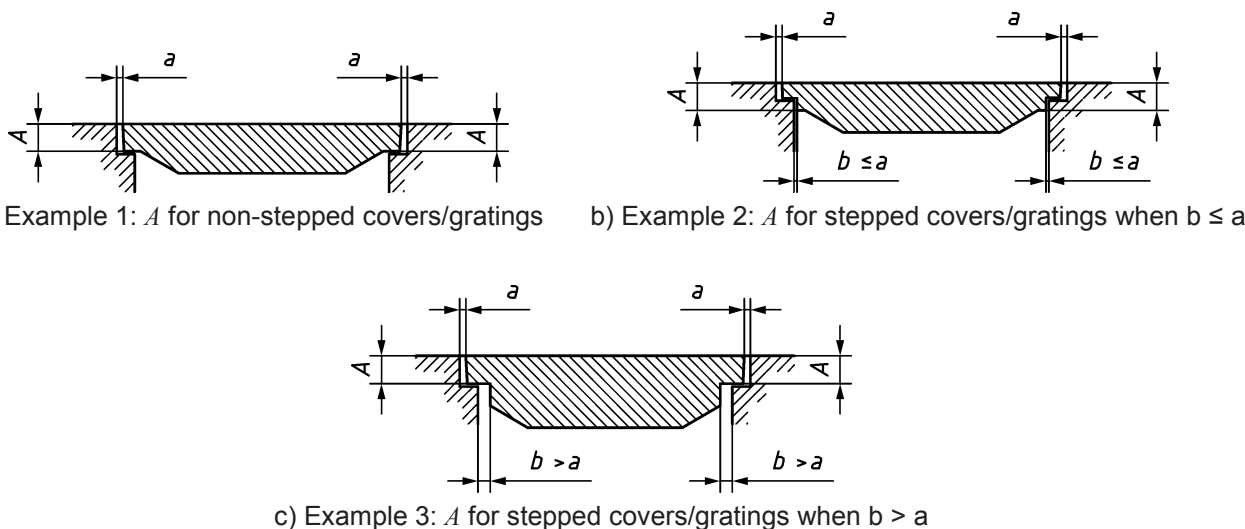

Figure 1 — Examples for determination of depth of insertion

**3.1.16
total clearance**

Σa
sum of the maximum individual clearances between adjacent elements of the frame and grating/cover

Note 1 to entry: Examples are shown in Figure 2 a), Figure 2 b) and Figure 2 c).

Note 2 to entry: The total clearance is expressed in millimetres (mm).

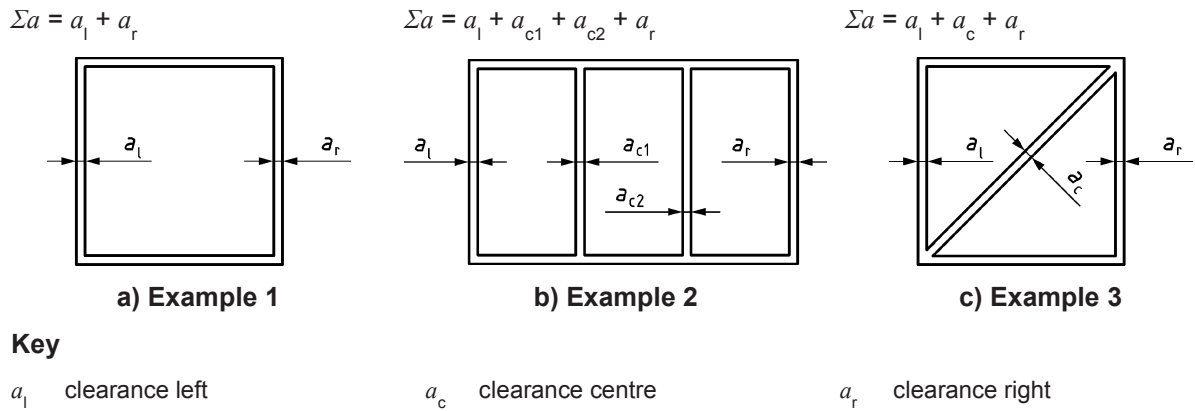

Figure 2 — Examples for the determination of total clearance

3.1.17
frame bearing area

A_b
surface of the underside of a frame which rests upon the supporting structure

Note 1 to entry: The bearing area is expressed in square millimetres (mm²).

3.1.18
clear opening

CO
diameter of the largest circle that can be inscribed in the clear area (3.1.19) of the frame

Note 1 to entry: Examples are shown in Figures 3 a) to 3 f).

Note 2 to entry: The clear opening is expressed in millimetres (mm).

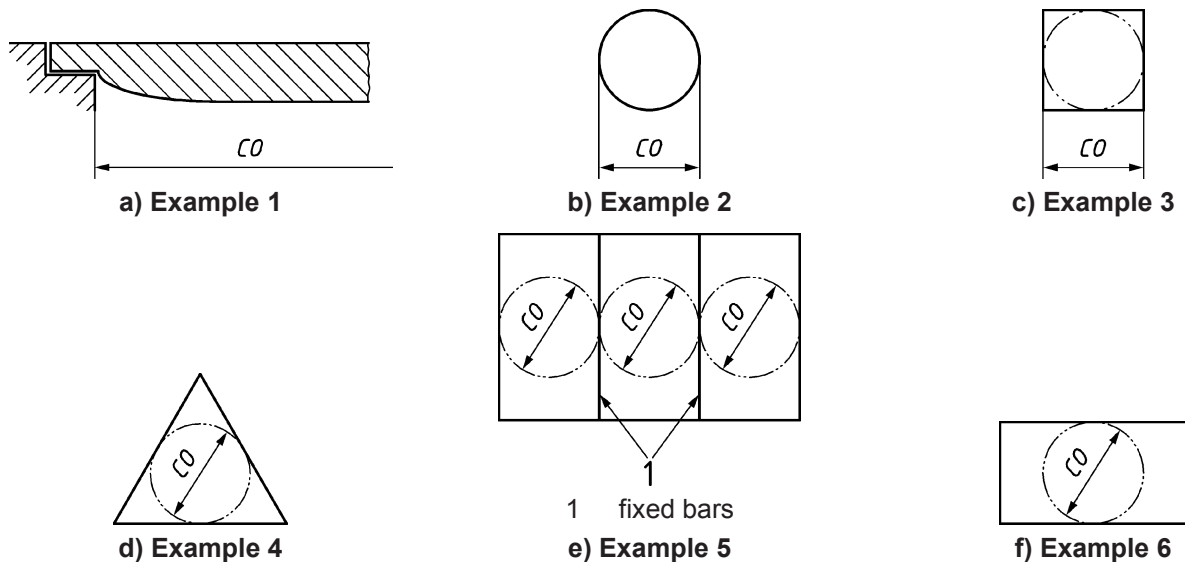

Figure 3 — Examples of clear opening

3.1.19
clear area

CA
unobstructed area between the seatings in the frame

Note 1 to entry: Examples for unobstructed areas are shown as the shaded area in Figure 4 a) to Figure 4 c). In the case that the area of seatings in the frame is interrupted by functional areas, for example, areas for drainage of water, areas for holding dirt pans or means for access to manholes and spaces for hinges, locking and securing systems, these functional areas are not considered for the calculation of mass per unit area. If there are more possibilities the larger of the possible clear areas need to be used.

Note 2 to entry: The clear area is expressed in square millimetres (mm²).

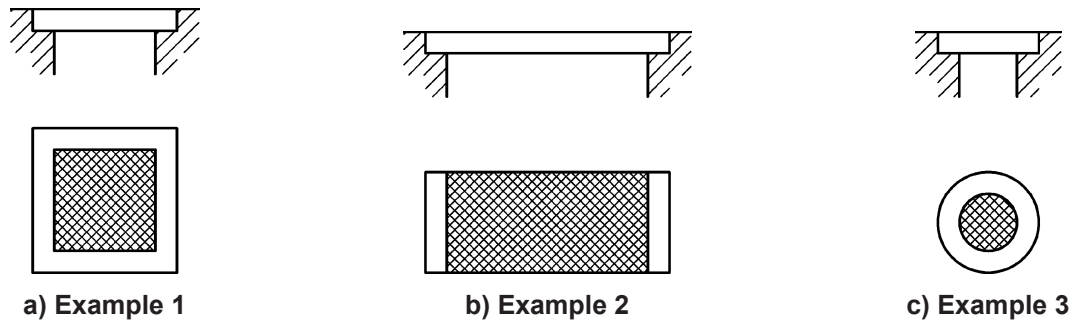

Figure 4 — Examples of clear area

3.1.20
waterway area

overall effective drainage inlet area on the top surface of gully tops and in kerb units

Note 1 to entry: The waterway area is expressed in square millimetres (mm²).

3.1.21
securing feature

feature which is integral with frame or cover(s)/gratings(s) or installed as part of the manufacturing process to safely retain cover(s)/gratings(s) in the frame under traffic conditions in the place of installation and to prevent inappropriate movement of the cover(s)/gratings(s) such as ejection and non-intended lifting

EXAMPLE Screws, bolts, spring bars, etc.

3.1.22
mass per unit area

total mass of the cover or the grating in kilograms divided by the clear area in square metres

Note 1 to entry: The mass per unit area is expressed in kg/m².

3.1.23
cushioning insert

accessory provided within a frame, grating or cover to achieve stability and quietness in use

3.1.24
test load

F_T
load applied to gully tops or manhole tops for testing the load bearing capacity

Note 1 to entry: The test load is expressed in kilonewtons (kN).

3.1.25

permanent set load

F_P

load applied to gully tops or manhole tops for testing the permanent set ($F_P = 2/3 F_T$)

3.1.26

deflection load

F_D

load applied to gully tops or manhole tops for testing the deflection under load ($F_D = 1/3 F_T$)

3.1.27

pedestrian area

area reserved for pedestrians and only occasionally open to vehicular traffic for delivery, cleaning purposes or in an emergency

3.1.28

pedestrian street

area where vehicular traffic is prohibited during certain periods (e.g. pedestrian areas during business hours and vehicular traffic outside these hours)

3.1.29

locking accessory

added component to prevent unauthorised lifting, opening or removal of cover/grating

3.2 Symbols and abbreviated terms

P_b Frame bearing pressure

USRV unpolished skid resistance value

4 Classification

4.1 Basis of the classification

Based on the test loads according to Table 4, gully tops or manhole tops shall be classified into one of the following classes:

A 15, B 125, C 250, D 400, E 600 or F 900.

4.2 Classification in the context of intended use

This clause provides the link of the classification and the place of installation. For different classes of manhole tops or gully tops provisions in the place of installation shall be taken into account.

The appropriate class of a manhole top or a gully top to be used depends upon the place of installation. The various places of installation have been divided into groups numbered 1 to 6, as listed below. Figure 5 and Figure 6 show the location of some of these groups in a highway environment. The minimum class recommended for use in each group is shown in brackets. The selection of the appropriate class and the material is the responsibility of the specifier. Where there is any doubt, the stronger class should be selected.

- **Group 1 (at least class A 15):** Areas which can only be used by pedestrians and pedal cyclists.
- **Group 2 (at least class B 125):** Pedestrian areas and comparable areas, car parks or car parking decks.
- **Group 3 (at least class C 250):** For gully tops, installed in the area of kerbside channels of roads (Figure 5) which, when measured from the kerb edge, extends a maximum of 0,5 m into the carriageway and a maximum of 0,2 m into the pedestrian area.

- **Group 4 (at least class D 400):** Carriageways of roads (including pedestrian streets), hard shoulders (Figure 6) and parking areas, for all types of road vehicles.
- **Group 5 (at least class E 600):** Areas imposing high wheel loads, e.g. docks, aircraft pavements.
- **Group 6 (class F 900):** Areas imposing particularly high wheel loads, e.g. aircraft pavements.

NOTE 1 Compliance of the product with the respective part of EN 124 series does not replace the responsibility of the user to ensure that the gully top or the manhole top is correctly installed and its elements (frame and grating/cover) have the necessary performance values.

For concave gratings the places of installation shall be limited to the following places of intended uses:

- Groups 1, 2 and 3;
- Group 4, for parking areas only.

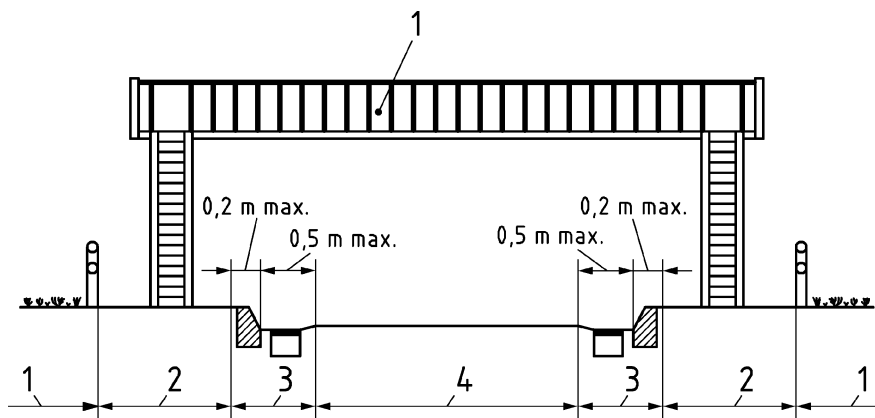

- Key**
- 1 Group 1
 - 2 Group 2
 - 3 Group 3
 - 4 Group 4

Figure 5 — Typical highway cross-section showing the location of the groups

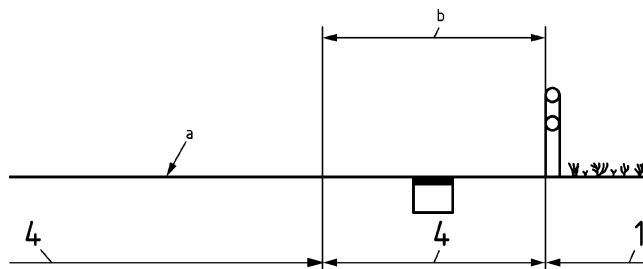

- Key**
- 1 Group 1
 - 4 Group 4
 - a carriage way
 - b hard shoulder

Figure 6 — Typical detail of a hard shoulder showing the location of the groups

NOTE 2 Recommendations for installation are given in Annex F.

5 Materials

5.1 General

Materials used for manhole tops and gully tops shall meet the requirements specified in

- EN 124-2, for gully tops and manhole tops made of cast iron,
- EN 124-3, for gully tops and manhole tops made of steel or aluminium alloys,
- EN 124-4, for gully tops and manhole tops made of precast steel reinforced concrete,
- EN 124-5, for gully tops and manhole tops made of composite materials,
- EN 124-6, for gully tops and manhole tops made of polypropylene (PP), polyethylene (PE) or unplasticized poly(vinyl chloride) (PVC-U).

All materials used shall be compatible, e.g. detrimental electro chemical or galvanic corrosion shall be avoided.

Manhole tops and gully tops resulting of a combination of elements made from different materials as specified in EN 124-2, EN 124-3, EN 124-4, EN 124-5 or EN 124-6 shall comply with EN 124-1, and elements shall comply with the relevant requirements of the material related EN 124-2, EN 124-3, EN 124-4, EN 124-5 and EN 124-6. The class of the combined product shall be restricted to the lower class determined of any constituent element according to the relevant part of EN 124-2, EN 124-3, EN 124-4, EN 124-5 or EN 124-6 and be marked accordingly.

Manhole tops and gully tops according to this standard shall be at least suitable for use in wet and dry conditions and a slightly aggressive chemical environment, i.e. normal conditions for domestic sewage and treated industrial effluent, and for most natural soils and groundwaters. If more severe conditions are expected, additional requirements for corrosion protection can be necessary.

5.2 Cover fillings

Cover fillings are only applicable to manhole tops in accordance with EN 124-2 or EN 124-3.

In the case of covers placed on the market in filled condition, the filling materials shall comply with the requirements in accordance with EN 124-2 or EN 124-3.

In case of covers placed on the market in unfilled condition and the filling is applied subsequently, the filling materials shall have a minimum performance comparable to concrete or the surrounding pavement materials and shall fulfil the requirements of the appropriate European Standards.

5.3 Frames in combination with concrete

Where the frame is made of a combination of any material according to this standard and concrete, the concrete shall have a compressive strength of at least C35/45 in accordance with EN 206:2013.

6 Design requirements

6.1 Vents in covers

Covers can be designed with or without vents. For covers with vents the minimum vent area shall conform to Table 1 and their dimensions shall conform to Table 2.

Table 1 — Minimum vent area

Clear opening CO	Minimum vent area cm ²
≤ 600 mm	5 % of the area of a circle having a diameter equal to the clear opening
> 600 mm	140

Table 2 — Dimensions of vents

Class	Dimensions of slots mm		Diameters of holes mm
	Length	Width	
A 15 and B 125	≤ 170	18 to 25	18 to 38
C 250 to F 900	≤ 170	18 to 32	30 to 38

6.2 Clear opening of manhole tops for man entry

The clear opening of manhole tops shall be declared in the product documentation.

NOTE In the vast majority of Member States the clear opening is considered to be at least 600 mm for man entry. In some other Member States larger openings are required.

6.3 Depth of insertion

Gully tops and manhole tops of classes D 400, E 600 and F 900 with the exception of those secured according to 6.6 a), shall have a depth of insertion A of minimum 50 mm (see 3.1.15).

6.4 Clearance

6.4.1 Total clearance

The clearance between the different elements of gully tops and manhole tops is defined in 3.1.16. This clearance can lead to horizontal displacement of the cover or grating in its frame. In order to limit this displacement, the total clearance Σa , shall conform to the following requirements:

- a) for covers or gratings in one or two parts:
 - 1) clear opening $CO \leq 400$ mm: $\Sigma a \leq 7$ mm,
 - 2) clear opening $CO > 400$ mm: $\Sigma a \leq 9$ mm;
- b) for covers or gratings with three or more parts secured in the frame each individual clearance (a_1, a_c, a_r) shall be limited to a maximum of 5 mm;
- c) for covers or gratings with three or more parts not secured in the frame, the total clearance Σa resulting from the displacement of all parts shall not exceed 15 mm.

6.4.2 Clearance around hinges

Where hinged covers or gratings have a radial profiled edge on the hinged side, it shall be profiled so that the gauge of 170 mm × 170 mm × 20 mm, as shown in Figure 7, is prevented from entering the gap between the adjacent frame and the curved edge of the cover or grating by no more than 13 mm.

The gauge shall be held vertical and its 170 mm edge parallel to the profiled edge. In addition the gap shall not exceed the maximum slot dimensions in accordance with Table 3. The tolerance of the gauge shall be $\pm 0,2$ mm with a maximum radius of 1 mm.

Slots between two hinges of covers or gratings shall not exceed the dimensions in accordance with Table 3.

Dimensions in millimetres

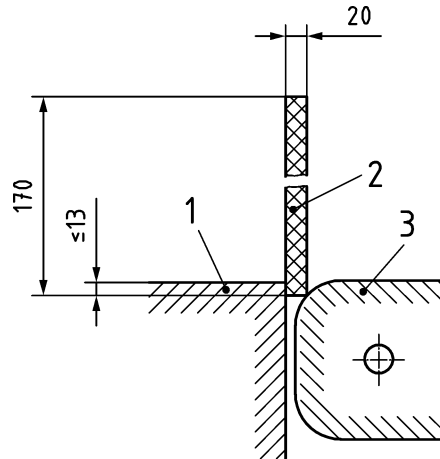

Key

- 1 frame
- 2 gauge
- 3 cover or grating

Figure 7 — Gauge

6.5 Compatibility of seatings

Gully tops and manhole tops of all classes shall be such as to ensure the compatibility of their respective seatings. This shall be assessed by assembling the cover/grating and the frame.

In addition, for classes D 400 to F 900 these seatings shall be designed/manufactured in such a way as to ensure quietness in use and stable behaviour. This can be achieved by machining of the contact surfaces, or the use of cushioning inserts, or three-point suspension design or any other appropriate methods. When tested according to 8.4.5, the cover/grating shall not have an increased change in height above the upper edge of the frame by more than $0,5 \times$ depth of insertion with a maximum value of 25 mm at any point on the perimeter.

6.6 Securing of the cover/grating within the frame

The cover/grating shall be secured within its frame to meet the required conditions relevant to the intended place of installation defined in 4.2.

This shall be achieved by at least one of the following methods (see also Table E.1):

- a) securing feature;
- b) mass per unit area;
- c) other methods.

These methods shall be designed so as to allow opening of the covers or gratings by means of usual tools, except in the case where the specifier requests an additional locking system. For securing methods according to a) and c) the corrosion resistance shall be at least equivalent to the frame or the cover/grating or the materials in accordance with EN 124-2 or EN 124-3.

The securing of covers/gratings within the frames shall be tested in accordance with 8.4.6. The securing method and design details shall be declared.

Where required by specific provisions in the place of intended use, the above mentioned methods for securing of cover(s)/grating(s) shall comply with these provisions.

NOTE For purposes such as prevention of unauthorized removal, lifting of cover/gratings or vandalism additional locking accessories can be required by the specifier. The selection of the appropriate locking accessory is in the responsibility of the specifier. The provision of the appropriate locking accessory is, in this case, not within the responsibility of the manufacturer.

6.7 Handling of covers and gratings

Provision shall be made for the effective loosening and for the opening of the covers and gratings by means of usual tools. Additional lifting features and/or devices can be incorporated in the design of manhole tops and/or gully tops.

NOTE The design and performance of these additional features or devices are not covered by this standard.

6.8 Slot dimensions of gratings

6.8.1 Waterway area

For all classes the dimensions of slots in gratings shall be selected having regard to the hydraulic capacity and the slots shall be evenly distributed over clear area. The waterway area shall not be less than 30 % of the clear area and shall be provided by the manufacturer.

6.8.2 Slot dimensions

The slots in gratings shall have the dimensions stated in Table 3. The dimensions of slots for classes C 250 to F 900 shall be dependent on the orientation of the longitudinal axis of the slots in relation to the direction of traffic, in accordance with Table 3 and Figure 8.

NOTE 1 The dimensions of the waterway area and the openings of side entry or kerb gullies are not specified in this document.

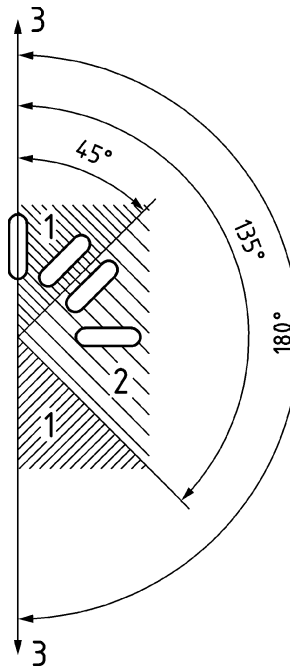

Key

- 1 orientation pos. 1
- 2 orientation pos. 2
- 3 direction of traffic

Figure 8 — Orientation of slots in gratings

Table 3 — Slot dimensions

Openings			Class	Width ^a (mm)	Length (mm)
Straight slots	Orientation according to Figure 8	Pos. 1 and Pos. 2	A 15 and B 125	8 to 18	No limitation
				> 18 to 25	≤ 170
		Pos. 1	C 250 to F 900	16 to 32	≤ 170
		Pos. 2	C 250	16 to 42	No limitation
			D 400 to F 900	18 to 42	No limitation
Slots in other shapes	Slots in other shapes shall not exceed a width of 25 mm for classes A 15 and B 125 and a width of 42 mm for classes C 250 to F 900. They shall be designed in such a way as to prevent the 170 mm length of the gauge from entering the slot. The gauge shall be held vertically with its 170 mm edge parallel to the surface of the grating.				
^a In pedestrian areas and/or pedestrian streets, a reduction of the slot width to 5 mm is permitted.					

NOTE 2 The minimum width values of this table do not apply for the slots immediately adjacent to the hinged side of the grating associated with the opening of the grating (see 6.4.2).

6.9 Dirt pans and dirt buckets

Where dirt pans or dirt buckets are specified, they shall be designed to ensure that drainage and ventilation can continue when the dirt pan or bucket is full.

6.10 Positioning of covers and gratings

Where the cover or grating has to be in a predetermined position relative to the frame, this shall be ensured by an appropriate design.

6.11 Flatness of manhole covers and gratings

The upper surface, of gratings and covers of classes D 400 to F 900, which is the surface in contact with traffic, shall be flat within a tolerance of 1 % of the clear opening with a maximum of 6 mm.

6.12 Concaveness of gratings

Gratings designed with a dished surface exceeding 6 mm are described as concave.

6.13 Surface conditions

When tested in accordance with 8.4.13, the surface conditions shall be in accordance with 7.4.

NOTE In certain environments such as, but not limited to, legally required studded tyres or legal toxic emissions limitations, the specifier can request further appropriate tests to be carried out to check if these are fit for purpose at the place of installation.

6.14 Manhole tops with sealing features

Manhole tops in accordance with this standard can be designed with sealing features to resist against accidental upward water pressure. In such a case the frame shall be designed to be securely anchored.

Manhole tops according to this standard can also incorporate sealing features to prevent or limit:

- the escape of odours through the manhole top (non-pressure); or
- non-pressure surface water ingress (rain water).

The design and performance of the sealing features are not covered by this standard.

6.15 Frame bearing area

The frame bearing area shall be designed in such a way that the bearing pressure P_b on the basis of the test load F_T shall not exceed $7,5 \text{ N/mm}^2$ to provide a contribution to stability under working conditions. The bearing pressure P_b shall be calculated in accordance with Formula (1):

$$P_b = \frac{F_T}{A_b} \quad (1)$$

where

A_b is the frame bearing area in mm^2 .

NOTE P_b is expressed in N/mm^2 .

6.16 Frame depth

The depth of the frame of manhole tops or gully tops of class D 400, E 600 and F 900 shall be at least 100 mm.

For class D 400 the frame depth may be reduced to 75 mm provided that the frame is made either of cast iron or steel and provides anchoring facilities.

6.17 Opening angle of hinged covers/gratings

The opening angle of hinged covers or gratings shall be at least 100° to the horizontal unless additional stays are provided.

NOTE Additional provisions can be required to prevent the cover or grating from accidental closing, e.g. site or service conditions.

6.18 Covers with fillings

Covers with fillings and covers designed to be filled subsequently shall comply with EN 124-2 for gully tops and manhole tops made of cast iron or EN 124-3 for gully tops and manhole tops made of steel or aluminium alloys. The manufacturer shall provide all necessary instructions for filling unless the filling has been carried out at the manufacturer's plant.

7 Performance requirements

7.1 Appearance

Gully tops and manhole tops shall be free from visible defects which might impair their fitness for use.

7.2 Load bearing capacity

When tested according to 8.3 gully tops and manhole tops with a clear opening (*CO*) equal to or greater than 250 mm shall withstand the test load according to Table 4 for each class independent of the material. Where the clear opening (*CO*) is less than 250 mm, the test load shall be as shown in Table 4, multiplied by *CO*/250 but not less than 0,6 times of the test load according to Table 4.

Covers/gratings and frames made of materials according to EN 124-2, EN 124-3, EN 124-5 and EN 124-6 shall not show cracks or delaminations in the course of the test when viewed without magnification. For steel reinforced concrete the requirements of EN 124-4:2015, 5.2.2 shall be met.

The load bearing capacity shall be declared as corresponding class according to Table 4.

Table 4 — Test loads

Class	A 15	B 125	C 250	D 400	E 600	F 900
F_T in kN	15	125	250	400	600	900

NOTE For class A, the manufacturer can, if requested by the specifier, declare the test load achieved.

7.3 Permanent set

When tested according to 8.2, the permanent set of the cover or grating after the application of F_P ($2/3$ of the test load F_T) shall not exceed the values given in Table 5.

Covers/gratings and frames, made of materials according to EN 124-2, EN 124-3, EN 124-5 and EN 124-6, shall not show cracks or delaminations in the course of the test when viewed without magnification. For steel reinforced concrete the requirements of EN 124-4:2015, 5.2.2, shall be met.

Table 5 – Permissible permanent set

Class	Permissible permanent set	
	mm	
A 15 and B 125	$\frac{CO}{100}^a$	
C 250 up to F 900	$\frac{CO}{300}^b$	$\frac{CO}{500}^c$
	When secured according to 6.6 a) or 6.6 c)	When secured according to 6.6 b)
^a CO/50 for CO < 450 mm with a maximum value of 6,5 mm. ^b 1,0 mm max. when CO < 300 mm. ^c 1,0 mm max. when CO < 500 mm.		

7.4 Skid resistance

7.4.1 General

All manhole tops and gully tops shall be skid resistant in their field of application. This can be achieved

- a) by meeting the requirements on design according to 7.4.2 a) or b) for covers and/or 7.4.3 for gratings and 7.4.4 for frames, or
- b) by testing according to 7.4.2 c) for covers and 7.4.4 for frames.

7.4.2 Skid resistance of covers

The upper surface of covers shall be in accordance with at least one of the following requirements:

- a) made of concrete, provided that the upper surface of the cover has been neither ground nor polished;

NOTE 1 Additional provisions can be required to prevent the concrete cover or concrete filled cover from potential skid, e.g. where concrete mix contains fine limestone aggregates.

- b) shall have a structured upper surface with a defined raised pattern or a coarse textured upper surface which permits free drainage/dispersion of water to the surrounding area and complies with the following dimensional requirements:
 - When measured from the total plan surface, the raised pattern shall have a height of 2 mm to 6 mm for classes A 15, B 125, and C 250 and a height of 3 mm to 8 mm for classes D 400, E 600, and F 900.
 - The raised pattern shall be distributed as far as possible evenly over the total plan surface area of the manhole top.
 - The total surface area of raised pattern ($\sum A_n$) shall be not less than 10 % and not more than 70 % of the total projected surface area (A_{T2}).
 - The surface area of any single raised pattern defined as A_n shall be determined as shown in Figure 9.

Parts of logo that are within the height requirements are considered as part of the raised pattern and shall provide free drainage/dispersion of water.

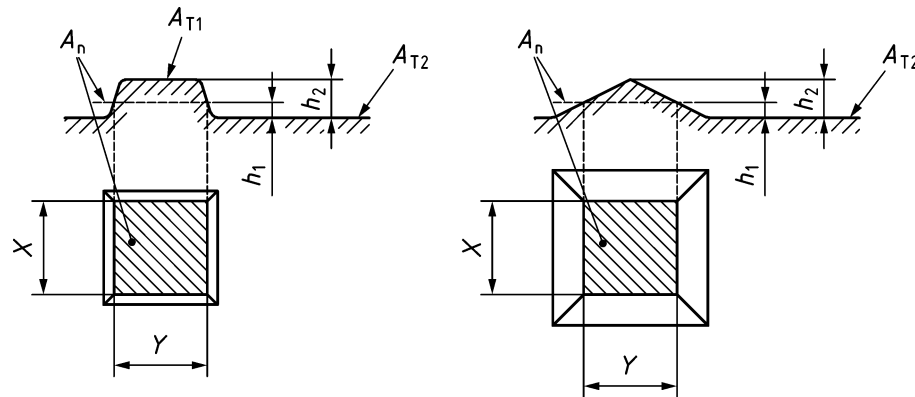

Key

A_n	surface area of a single raised pattern at height h_1 as measured from the total plan surface of the manhole top	A_{T1}	upper surface of raised pattern
h_2	height of raised pattern	A_{T2}	total projected surface area of manhole top
h_1	minimum height of raised pattern	Y	length of raised pattern measured at A_n
		X	width of raised pattern measured at A_n

Figure 9 — Example for determination of raised pattern

- c) shall have a USRV of not less than 35 when tested according to Annex C, where the surface of the cover does not fulfil the requirements of a) and/or b).

NOTE 2 Explanation on the use of the Pendulum test method is given in Annex G (informative).

7.4.3 Skid resistance of gratings

Gratings with slot dimensions in accordance with 6.8.2 are deemed to satisfy the skid resistance. Where a raised pattern is provided it shall have a height of 2 mm to 6 mm for classes A 15, B 125, C 250 and a height of 3 mm to 8 mm for classes D 400, E 600 and F 900.

7.4.4 Skid resistance of frames

If frames or parts thereof have a horizontal visible width exceeding 40 mm, the requirements for covers according to 7.4.2 shall also apply for these frames.

7.5 Child safety

Where required by specific provisions in the place of intended use child safety features and/or devices shall be incorporated in the design of manhole tops and/or gully tops.

The resistance of covers or gratings to removal by children shall be met by one of the following means:

- mass of the individual covers or gratings;
- securing feature; or
- locking accessory.

Where a locking accessory or securing feature is used, it shall be designed so that the cover or grating cannot be easily opened with objects readily accessible by children.

8 Testing

8.1 General

Gully tops and manhole tops shall be tested as complete units in their intended position of use where cover/grating is suitably positioned within the frame and the frame is supported in a manner to replicate intended installation support structure.

Gully tops and manhole tops consisting of covers with fillings or covers designed to be filled subsequently, shall be tested in accordance with A.1 and B.1.

Manhole tops and gully tops resulting of a combination of elements made from different materials as specified in EN 124-2, EN 124-3, EN 124-4, EN 124-5 and EN 124-6 shall be tested as complete units in accordance with 5.1.

All tested products shall be visually inspected without magnification.

NOTE For manhole tops and gully tops consisting of double or multiple triangular covers/gratings, the manufacturer can, if requested by the specifier, carry out additional tests (see note to A.4.2 and Annex G).

8.2 Permanent set (see 7.3)

The permanent set of the cover or grating shall be determined according to Annex A after the application of $F_P = 2/3 F_T$ (F_T as given in 7.2) without pre-loading. The permanent set shall be measured to an accuracy of 0,1 mm.

8.3 Load bearing capacity (see 7.2)

Immediately after the test according to 8.2 all gully tops and manhole tops shall be submitted to the load bearing capacity test according to Annex B under the test loads F_T according to 7.2.

8.4 Verification of design requirements

8.4.1 Vents (see 6.1)

Vent slots and holes shall be measured to an accuracy of 1 mm. The vent area shall be calculated to the nearest 100 mm².

8.4.2 Clear opening (see 6.2)

The dimensions of the clear opening (CO) shall be measured to the nearest 1 mm.

8.4.3 Depth of insertion (see 6.3)

The depth of insertion (A) and the clearance values a and b shall be measured to the nearest 0,5 mm.

8.4.4 Clearance (see 6.4)

The clearances between covers or gratings and frames shall be measured to an accuracy of 0,5 mm and the total clearance (Σa) shall be calculated. The clearance around a hinge shall be controlled by using a gauge of 170 mm × 170 mm × 20 mm.

8.4.5 Compatibility of seatings (see 6.5)

The compatibility of the seatings shall be inspected to the specification of the manufacturer.

In addition gully tops and manhole tops of classes D 400 to F 900 shall be tested in accordance with Annex D.

8.4.6 Securing of the cover and/or grating within its frame (see 6.6)

The securing of covers/gratings of classes C 250 to F 900 within the frames shall be tested in accordance with Annex E.

The declared securing method shall be visually inspected with respect to the function, the use of materials and the declared values according to E.2.7 corresponding to the design details.

If securing is achieved by 6.6 b) weighing of the mass is sufficient. In this case the cover/grating shall be weighed to an accuracy of 1 % and the clear area calculated to an accuracy of 100 mm².

8.4.7 Handling of covers and gratings (see 6.7)

The handling of covers and gratings shall be tested physically for loosening and opening according to manufacturer's instructions.

8.4.8 Slot dimensions (see 6.8)

The even distribution of the slots over the clear area shall be visually inspected. The waterway surface area shall be calculated to the nearest 100 mm².

The dimensions of straight slots shall be measured to the nearest 1 mm. The dimensions of slots other than straight shall be controlled by a gauge of 170 mm × 170 mm × 20 mm.

8.4.9 Dirt pans and dirt buckets (see 6.9)

The gully top or manhole top with a full dirt bucket/pan shall be visually inspected to ensure that both drainage and ventilation is still possible.

8.4.10 Positioning of covers and gratings (see 6.10)

The positioning of covers and gratings according to 6.10, if appropriate, shall be visually inspected. The appropriate design feature that ensures a particular orientation of the cover or grating in the frame shall be examined for fitness for purpose.

8.4.11 Flatness of covers and gratings (see 6.11)

The flatness shall be measured to an accuracy of 0,5 mm.

8.4.12 Concaveness of gratings (see 6.12)

The maximum depth shall be measured to an accuracy of 0,5 mm.

8.4.13 Skid resistance (see 7.4)

The skid resistance of the upper surface of the cover/grating and the frame shall be determined as follows:

- a) In case of concrete according to 7.4.2 a), the cover/grating shall be inspected according to the manufacturer's declaration that it has not been polished or ground and conforms to the provisions in accordance with EN 124-4 for the relevant material.

NOTE Where aggregates contain fine limestone, additional provisions to prevent the concrete cover or concrete filled cover from potential skid can be necessary.

- b) In case of a defined raised pattern as specified in 7.4.2 b) the height of the raised pattern shall be measured to an accuracy of 0,5 mm. The total surface area of raised pattern of the cover and frame shall be determined either by reference to the drawing and subsequently controlled by visual inspection, or by

measuring the dimensions of the upper surface of the raised pattern to an accuracy of 100 mm². The percentage of the total surface area of raised pattern shall be calculated.

- c) In case of products not conforming to 7.4.2 a) and 7.4.2 b), the surface condition shall be measured according to Annex C.

8.4.14 Frame bearing area (see 6.15)

The bearing area shall be calculated.

8.4.15 Frame depth (see 6.16)

The depth of the complete frame shall be measured to the nearest 1 mm.

8.4.16 Opening angle (see 6.17)

The opening angle shall be measured to an accuracy of 5°.

8.5 Child safety

The resistance of covers or gratings to removal by children shall be tested according Annex E and declared as:

- sufficient mass, or
- sufficient pull-out-force.

9 Assessment and verification of constancy of performance (AVCP)

Assessment and verification of constancy of performance shall be carried out in accordance with EN 124-2, EN 124-3, EN 124-4, EN 124-5 and EN 124-6 as relevant for manhole tops and gully tops made of the materials specified in those standards.

Annex A (normative)

Permanent set test

A.1 Test Samples

Gully tops and manhole tops shall be tested as complete units in their condition of service. Units tested shall be new units that have not been subjected to any other load tests, and shall be randomly selected.

A.2 Permanent set test load, (F_P)

A test load $F_P = 2/3 F_T$, (F_T as given in 7.2), shall be applied 5 times in succession on the same unit for each class for all clear openings.

A.3 Apparatus

A.3.1 Testing machine

The testing machine, preferably a hydraulic test press, shall be capable of applying a load at least 25 % greater than the respective test load, F_T , for classes A 15 to D 400 and at least 10 % greater than the respective test load, F_T , for classes E 600 and F 900.

The test machine shall comply with EN ISO 7500-1:2004, class 3.

Except for multiple units, the dimensions of the bed of the testing machine shall be greater than the bearing area of the unit to be tested.

A.3.2 Test blocks

The dimensions and shape of test blocks shall be as shown in Table A.1.

A.3.3 Measurement device(s)

The measurement device(s) shall have a resolution of at least 0,01 mm and have a maximum overall accuracy of ± 5 %.

Table A.1 – Dimensions of test blocks

Dimensions in millimetres

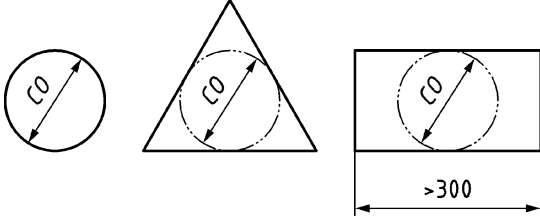
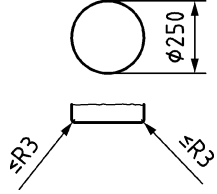
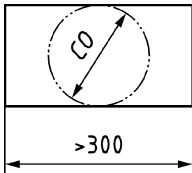
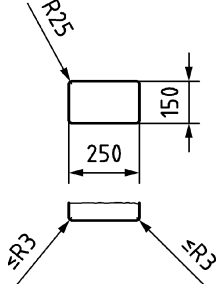
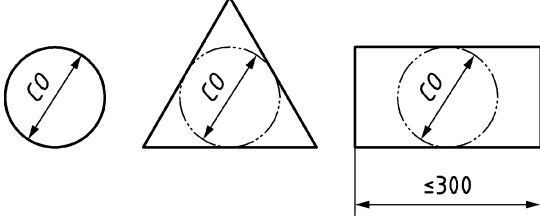
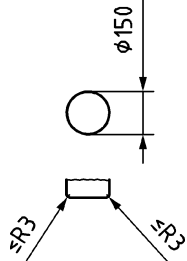
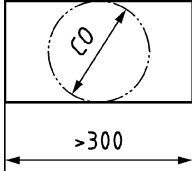
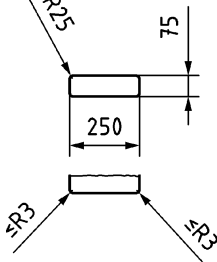
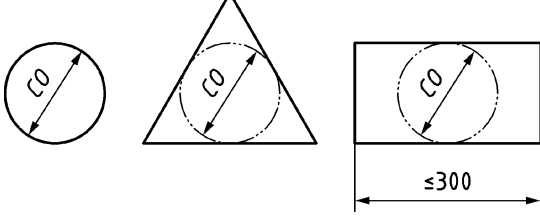
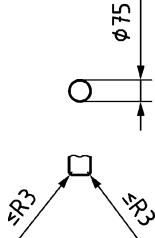
Clear opening	Shape of gully top or manhole top	Dimensions of the test blocks
300 < CO ≤ 1 000		
200 ≤ CO ≤ 300		
200 ≤ CO ≤ 300		
CO < 200		
CO < 200		

A.4 Procedure

A.4.1 Procedure for testing rectangular and circular covers/gratings

The test sample shall be placed on the test machine and the frame shall be supported on the bed of the test machine in such a way as to ensure that when the cover or grating is deflected under the test load, it shall

remain unsupported, and not in contact with the bed of the test machine. The cover or grating of the test sample shall rest normally in its frame.

The test block shall be placed on the geometric centre of the cover/grating with its vertical axis perpendicular to the surface of the cover or the grating (examples, see Figure A.1).

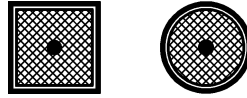
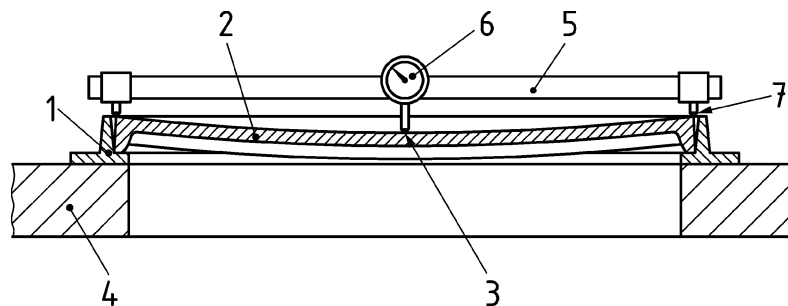

Figure A.1 — Testing points for manhole tops and gully tops with rectangular and circular covers/gratings

The test load shall be uniformly distributed over the whole surface of the test block and any irregularities compensated for by means of an appropriate intermediate layer, e.g. softwood, fibre board, felt or similar material positioned between the cover or the grating and the test block. The dimensions of this intermediate layer shall not be larger than those of the test block. A similar intermediate layer, at the manufacturer's discretion, may also be positioned between the bed of the testing machine and the bearing area of the sample under test.

When testing gully tops or manhole tops with a non-flat surface, the contact face of the test block shall be shaped to match the grating or cover. Patterns as defined in 7.4 and small deviations from a flat surface do not require a shaped contact face of the test block.

Measurement of permanent set shall be made on the upper-side of the gully grating or manhole cover in the same place as the applied test load at the longest dimension which can be inscribed within the cover through the centre point of the load application. The measurement device(s) shall be positioned as close as possible to the centre point of the load application (see Figure A.1 and Figure A.3) and the seating of the measuring device support as close as possible to the edge of the cover but not exceeding 10 mm from the edge. If the test block is positioned across two adjacent covers or gratings the permanent set shall be measured on both covers/gratings as close as possible to the centre point of the load application.



Key

- | | | | |
|---|------------------------|---|-------------------------------------|
| 1 | frame | 5 | measuring device support |
| 2 | cover or grating | 6 | measuring device |
| 3 | geometric centre | 7 | seating of measuring device support |
| 4 | bed of testing machine | | |

Figure A.2 — Measurement of permanent set

Before the first load, without preloading, is applied, an initial reading at the geometric centre of the cover or grating shall be taken.

The load shall be applied at a rate of 1 kN/s to 5 kN/s up to 2/3 of the test load ($F_P = 2/3 F_T$), F_T as given in 7.2. The load on the test specimen is then released. This procedure shall be carried out five times without

significant interruption. Then a final reading at the geometric centre shall be taken. The permanent set shall then be determined according to Figure A.2 as the difference of the measured readings before the first and after the fifth loading.

A.4.2 Procedure for testing triangular covers/gratings

The procedure for manhole tops and gully tops with triangular covers/gratings is the same as described in A.4.1, with the following differences according the positioning of the test block (example, see Figure A.3).

In the case of double or multiple triangular covers or gratings the test block shall be placed centrally on the diagonal edge between two covers (Figure A.3), with its vertical axis perpendicular to the surface and coincident with the diagonal edge between the covers. Where double or multiple triangular covers or gratings have identical pairs of covers/gratings only one pair of covers/gratings need to be tested. Where they are not identical then at minimum one pair of each non identical design shall be tested.



Figure A.3 — Testing point for manhole tops and gully tops with double or multiple triangular covers/gratings

NOTE In special cases it can be requested by the specifier to carry out additional tests. These tests are up to now not subject to this standard, but subject of an additional agreement between specifier and manufacturer. For more information, see Annex G.

Records shall be made of all readings. The differences between the “initial readings” and the equivalent “readings after application of the fifth load” shall be determined. A comparison shall be made between these differences and the requirements of this standard, and a report prepared accordingly.

Annex B (normative)

Test of load bearing capacity

B.1 Test samples

Gully tops and manhole tops shall be tested as complete units in their condition of service. This test shall be carried out on the same sample immediately after the permanent set test.

B.2 Test load (F_T)

The applied test load, F_T , shall be as shown in 7.2, for each class for all clear openings and all materials.

B.3 Test procedure

Apparatus, test machine, test blocks, measurement devices and the application of the test load shall conform to Annex A. Immediately after the permanent set test according to 8.2 and Annex A, the test load shall be applied at the same rate as given in Annex A, until it is achieved. The test load shall be maintained for (30^{+2}_0) s.

B.4 Test report

Record shall be made of the condition of the manhole top or gully top after removal of the test load and a report prepared accordingly.

Annex C (normative)

Test to determine the unpolished skid resistance value (USRV) of manhole covers

C.1 General

The measurement of USRV on a specimen shall be made using proprietary pendulum friction test equipment to evaluate the frictional properties of the specimen. The pendulum friction test equipment incorporates a spring loaded slider made of a standard rubber attached to the end of the pendulum. On swinging the pendulum, the frictional force between the slider and test surface is measured by the reduction in length of the swing using a calibrated scale.

C.2 Apparatus

Apparatus shall be

- a pendulum friction test equipment in accordance with EN 13036-4,
- potable water.

C.3 Calibration of pendulum friction test equipment

The pendulum friction test equipment shall be recalibrated at least once a year. This shall be carried out in accordance with EN 13036-4 by an approved calibration body.

C.4 Selection of test samples

Test samples shall be manhole covers or frames selected at random from the stock of manhole tops held by the manufacturer. Representative samples free from any temporary coatings, not yet used and free from any corrosion shall be selected and tested for each surface pattern design and for each material of manufacture.

This procedure shall also apply if the pattern is subsequently amended.

C.5 Test procedure

C.5.1 Validation and conditioning of the pendulum test equipment

The condition of the pendulum test equipment shall be checked according to the procedure for validation of the performance of a pendulum tester as described in EN 13036-4. If the validation results are outside the range of the standard surface, the used slider shall be conditioned in accordance with EN 13036-4.

After this conditioning, if the validation results are still outside the range of the standard surface, the apparatus shall be investigated and recalibrated if necessary.

The pendulum test equipment shall be conditioned for a period of at least 30 min prior to the commencement of the test. The test equipment, test specimen and slider as well as water, shall be kept at a temperature of (20 ± 5) °C, during this time.

C.5.2 Procedure to determine USRV

C.5.2.1 Preparation of sample

Surface irregularities (e.g. casting imperfections, etc.), dust or other contaminants shall be removed from the sample under test prior to testing.

C.5.2.2 Location of test areas

Where possible the test shall take place within a 0,5 m x 0,5 m grid as shown in Figure C.1. If it is clear that surface pattern varies across the test area, additional tests can be necessary to take this into account.

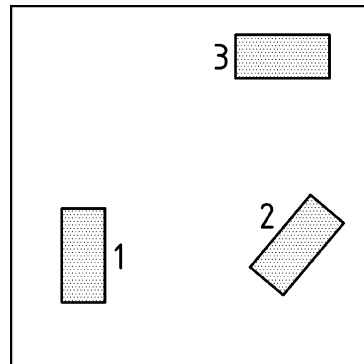

Key

- 1 Test location 1
- 2 Test location 2
- 3 Test location 3

Figure C.1 — Test locations

Testing shall be carried out at the three test locations as shown in Figure C.1, i.e. two shall be parallel to the major axes of the cover and one at an angle of 45° to the major axes. Where the test sample is smaller than 500 mm × 500 mm, a similar test pattern shall be adopted.

C.5.2.3 Setting up

The setting up of the pendulum, its zeroing and method of measurement shall be undertaken as described in EN 13036-4. In addition, the base of the pendulum tester shall be weighted with a suitable material of mass > 6 kg and < 10 kg to arrest any possible movement during testing.

C.5.2.4 Checking strike distance

Where the surface patterning of the cover does not enable a pendulum strike distance of 126 mm to be achieved (i.e. slider in contact with cover material at start and end of strike distance), a length of less than 126 mm may be chosen. In this case, the actual strike distance shall be recorded, and the values obtained after testing shall be modified by a correction factor. The correction factor shall be determined by reference to standard test materials. Such reference materials shall be tested using the same strike distance as on the sample and also using the standard distance of 126 mm. The correction factor shall be the ratio of the two results.

C.5.2.5 Measuring the value of each specimen

The height of the pendulum arm shall be checked and adjusted so that in traversing the specimen, the rubber slider is in contact with it over the whole width of the slider and over the specified sweep length. The upper

surfaces of the specimen and the rubber slider shall then be wetted with a copious supply of water just in front of the centre of the test location applied immediately before each swing of the pendulum, being careful not to disturb the slider from its set position.

The pendulum and pointer shall then be released from the horizontal position and the pendulum arm caught on its return swing, before it touches the test specimen a second time. The position of the pointer on the scale shall be recorded. This is the pendulum test value. This operation shall be repeated five times at each of the three locations shown in Figure C.1, rewetting the specimen each time. The last three of the five readings shall be recorded for each test location.

The mean value of the last three of the five readings shall be determined for each test location according to Figure C.1. This shall be the skid value for each location. The mean of the two lowest skid values shall be calculated.

Annex D (normative)

Tilt test

D.1 General

The stable behaviour of covers and/or gratings according to 6.5 is to be tested by the tilt test.

D.2 Test procedure

At the edges of the cover and the frame a test block of 75 mm diameter (smallest test block according to Table A.1), equipped with a rubber sheet of 75 mm diameter with a thickness of 10 mm, hardness $(60 \pm 5)^\circ$, shore A according to EN ISO 868 at the bottom, shall be applied at the test points according to Figure D.2 to Figure D.6 (if applicable). The axis centre of the test block is positioned at the gap between cover/grating and frame.

A gradually increasing test load F_K from 0 kN to 50 kN is to be applied 3 times with a rate of 1 kN/s to 5 kN/s.

Under effect of the test load the tilting height Δh_K between the top of the frame and the top of the cover shall be measured according to Figure D.1. The test shall be carried out at a temperature of $(25 \pm 10)^\circ\text{C}$.

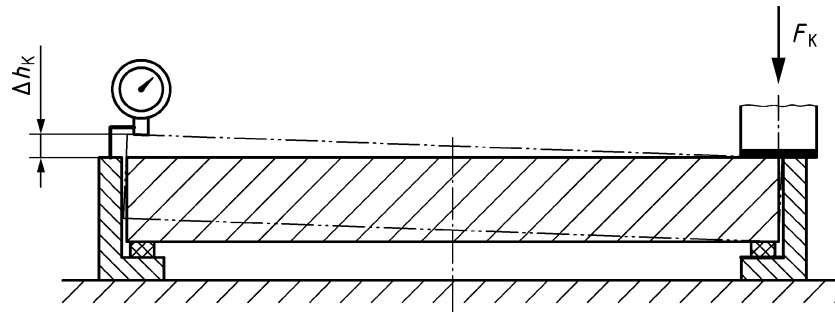

Key

F_K tilt test load

Δh_K tilting height (maximum increase)

Figure D.1 — Test equipment for measuring the tilting height

Table D.1 — Application of test load for different designs of manhole tops and gully tops

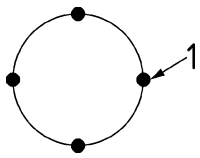
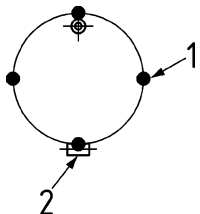
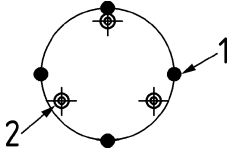
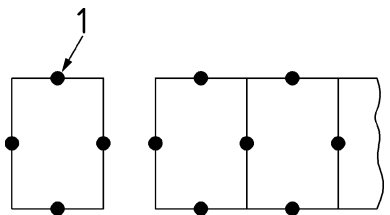
Design	Application of test load
round cover(s)/grating(s)	<p>In four places evenly distributed over the circumference according to Figure D.2.</p>  <p>Key 1 test point</p> <p style="text-align: center;">Figure D.2 — Circular covers/gratings</p>
cover(s)/grating(s) with hinges	<p>In four places evenly distributed over the circumference, where one point of load shall be applied immediately adjacent to the hinge according to Figure D.3.</p>  <p>Key 1 test point 2 hinge</p> <p style="text-align: center;">Figure D.3 — Hinges</p>
cover(s)/grating(s) with securing feature	<p>In four places evenly distributed over the circumference, where one point of load shall be applied immediately adjacent to one securing feature according to Figure D.4.</p>  <p>Key 1 test point 2 road worthy anchorage</p> <p style="text-align: center;">Figure D.4 — Securing feature</p>
rectangular cover(s)/grating(s)	<p>According to Figure D.5.</p>  <p>Key 1 test point</p> <p style="text-align: center;">Figure D.5 — Rectangular covers/gratings</p>

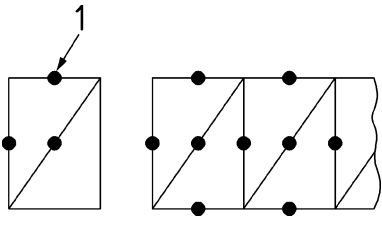
Design	Application of test load
triangular cover(s)/grating(s)	<p>According to Figure D.6.</p>  <p>Key 1 test point</p> <p style="text-align: center;">Figure D.6 — Triangular covers/gratings</p>
cover(s)/grating(s) with discontinuous depth of insertion	Where the depth of insertion varies due to cover/grating design, the test load shall be applied at each maximum depth of insertion and each minimum depth of insertion.

Annex E (normative)

Testing of securing of covers/gratings within the frame

E.1 General

The aim of the test is to assess the securing of the covers(s)/grating(s) within the frame of a manhole top or gully top by applying one or more pull-out forces to these covers/gratings and to measure their vertical movement.

The pull-out force F_v and $F_{v,c}$, as applicable, and the vertical displacement h of the cover(s)/grating(s), measured in the test, shall be declared.

The securing methods, defined in 6.6 and shown in Table E.1 shall be tested with the vertical pull-out test.

NOTE For 6.6 b) weighing of mass is sufficient (see 8.4.6).

The test shall be carried out after the tilt test described in Annex D.

Table E.1 — Assignment of securing methods to the test(s)

Securing method according to clause	
6.6 a)	Securing feature
	1 screws/bolts (on all multiple covers or on master one)
	2 spring bars or other clips (on all multiple covers or on master one)
	3 turn buckle device (on all multiple covers or on master one)
	4 other securing features
6.6 b)	Mass per unit area
	1 surface mass value: 200 kg/m ²
	2 surface mass value: 250 kg/m ²
	3 surface mass value: 275 kg/m ²
	4 surface mass value: 300 kg/m ²
5 other surface mass values	
6.6 c)	Other methods
	1 hinged covers
	2 multiple hinged covers
	3 double tri (or other shape) coupled covers
	4 ramp/slide-out covers (machined or not)
5 other designs	

E.2 Vertical pull-out test procedure

E.2.1 Preparation of the test

The applied vertical pull-out forces shall be measured in newtons with a calibrated dynamometer or similar apparatus with a resolution of at least 10 N, capable of applying a force of at least 25 % greater than the maximum force.

The vertical direction of the pull-out force, F_v , shall be measured with an appropriate device with an accuracy of $\pm 5^\circ$.

For safety reasons, it is recommended to fix the frame of the test samples.

The measurement device(s) shall have a range of at least 30 mm with a resolution of at least 0,1 mm and have a maximum overall accuracy of $\pm 5\%$ to measure the vertical movement.

The vertical pull-out force F_v shall be applied vertically on each single cover/grating by means of a cable fixed at the geometric centre of the cover/grating. Examples are given in Figure E.1.

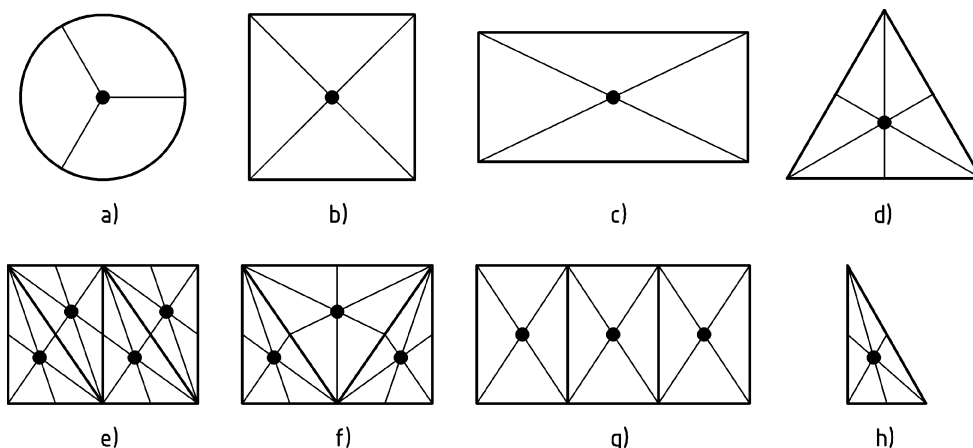

Figure E.1 — Examples for determination of the geometric centre of cover(s)/grating(s)

E.2.2 Testing arrangements

An appropriate anchoring device where the cable/chain/strap is secured shall be installed at the geometric centre of the cover/grating, e.g. screwed or welded.

This anchoring device, as shown in Figure E.2 shall be installed in such a way that:

- the distance between the top of the cover and the cable/chain/strap shall be (100^{+5}_0) mm;
- its longitudinal axis is fixed perpendicular to the cover surface level.

Dimensions in millimetres

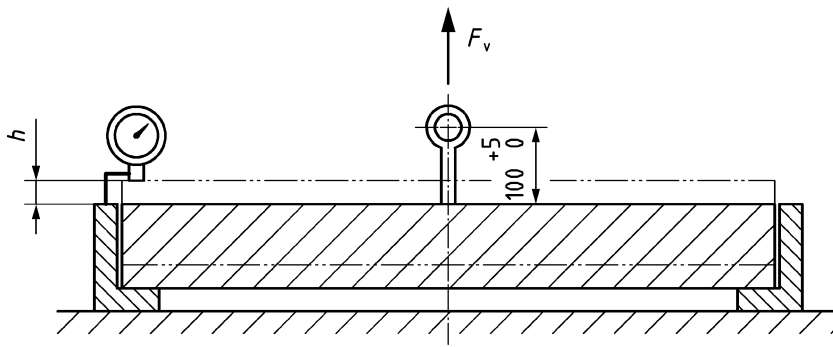

Key

- h vertical displacement
- F_v vertical pull out force

Figure E.2 — Example of vertical pull-out test arrangement

If, in the case of, as example gratings or specific covers, the geometric centre is not fit for the securing of the anchoring device, washers/plates installed on top surface and underneath or other accessories can be used to rebuild the centre, and allow the installation of the anchoring device.

If the cover does not remain in a horizontal position while it is moving in a vertical direction, it is necessary to determine the point of the largest change in position at which the measurement shall be made.

E.2.3 Determination of the maximum permissible vertical displacement, h

The vertical displacement shall not exceed 50 % of the depth of insertion A in accordance with 6.3, but with a maximum of 25 mm. The appropriate value of A (with a minimum value, where applicable) is to be determined.

E.2.4 Determination of the maximum pull-out force, F_v

E.2.4.1 Single cover

The maximum vertical pull-out force shall be determined according to Formula (E.1). The clear area shall be determined as shown in Figure E.3.

$$F_v = CA \times 0,4 \times 10^{-2} \tag{E.1}$$

where

F_v is the maximum vertical pull-out force in newtons;

CA is the clear area in mm^2 .

NOTE The Clear Area, CA , is used instead of Clear Opening, CO , to achieve a consistent evaluation of the various dimensions and types of covers.

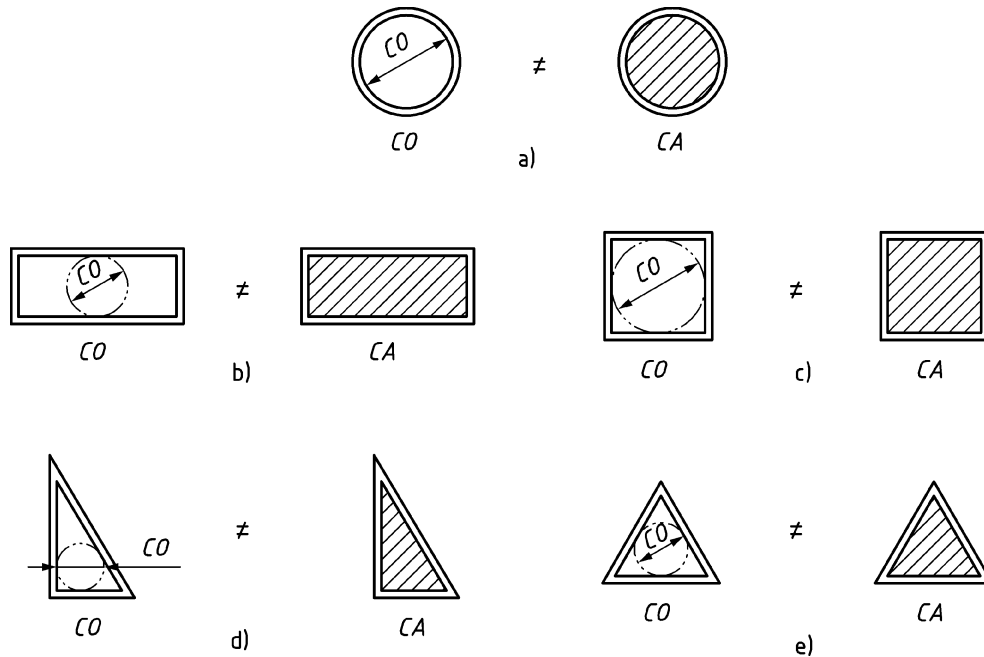

Figure E.3 — Examples of determination of clear areas of single covers/gratings

E.2.4.2 Multiple covers

The clear area of each individual cover shall be determined either on a drawing or at the sample in accordance with Figure E.4. The maximum vertical pull-out force shall be calculated in accordance with Formula (E.2) and applied at each individual cover.

$$F_{V,c} = CA_c \times 0,4 \times 10^{-2} \quad (\text{E.2})$$

where

$F_{V,c}$ is the maximum vertical pull-out force of each individual cover in N;

CA_c is the clear area of each individual cover in mm^2 .

NOTE The Clear Area, CA , is used instead of the Clear Opening, CO , to achieve a consistent evaluation of the various dimensions and types of covers.

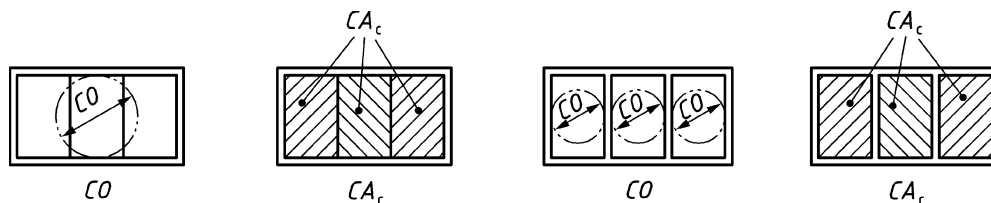

Figure E.4 — Examples of determination of clear areas of multiple covers/gratings

E.2.5 Application of the vertical pull-out force, F_v

The load shall be applied on each single cover at a rate of 0,01 kN/s up to 0,05 kN/s up to the lifting of the cover with a maximum of 25 mm or up to the maximum pull out force $F_{V,c}$ as calculated in E.2.4.2. The test shall be carried out 3 times consecutively and only the smallest vertical pull-out force, F_v , and its corresponding vertical displacement h shall be considered and declared.

In case of triangular covers with loose couplings, the loose couplings shall not be removed before the test.

E.2.6 Measurement of the vertical displacement h and of the pull-out force, F_v

The vertical displacement h shall be measured between the top of the frame and the highest point of the cover at the moment of lifting as shown in Figure E.2.

When the maximum permissible vertical displacement h is reached, the F_v or $F_{v,c}$ shall be measured and recorded.

E.2.7 Declaration of results

The smallest pull-out force F_v and its corresponding vertical displacement h measured for a single cover/grating in accordance with E.2.6 shall be declared.

In case of multiple covers the smallest pull out force $F_{v,c}$ of each individual cover and its corresponding vertical displacement h shall be declared.

Annex F (informative)

Recommendations for installation

F.1 General

The safe use of manhole tops and gully tops is dependent upon correct selection of the unit and good installation. This is particularly critical when they are installed in highway environments. The criteria listed below should be taken into account. A proper installation in the highway can also make a significant contribution to savings in the whole life costs of manhole tops and gully tops. Conditions in the place of use can require more detailed instructions.

F.2 Place of installation and selection of appropriate manhole tops and gully tops

A key responsibility for the safe location of a manhole top or gully top lies with the scheme planner.

Wherever possible, the underground chamber or gully upon which a manhole top or gully top is placed, should be located where traffic conditions are least arduous. However, wherever it is located, the designer has a responsibility to provide for future, as well as current traffic conditions. The designer should select an appropriate class of unit, for the chamber's or gully's location, in accordance with the recommendations of this standard and an appropriate clear opening size for safe entry.

F.3 Preparations before installation

Before installation the following should be checked:

- the manhole top or gully top is the correct size for the chamber or gully;
- the manhole top or gully top is of an appropriate class for its location;
- the manhole top or gully top is fixed with a particular orientation and it is properly aligned;
- the manhole top or gully top is appropriately marked, to show compliance with this standard, and with any third party's mark of conformity, if applicable;
- the manufacturer's installation guidance is available;
- the cover/grating and the frame form a matching set.

Manhole tops and gully tops are tested by manufacturers and certification bodies as a matching set. Generally they should be installed as such. The change of only one element may be undertaken on owners' request.

F.4 Operative skill, training and installation equipment

The installation of manhole tops and gully tops should be undertaken by appropriately skilled and trained operatives, using the proper equipment.

The user of the installation should ensure that any operatives or contractors (and their operatives) involved in the installation of manhole top or gully tops are appropriately competent to undertake the work.

The installer should ensure that all equipment used during the installation of manhole tops or gully tops:

- is properly maintained;
- is appropriate for the safe installation of the manhole top or gully top; and
- will cause no damage to the manhole top or gully top.

F.5 Bedding and packing materials

All bedding and packing materials should be used strictly in accordance with the manufacturer's recommendations. All such materials should be appropriate for use at the temperature prevalent at the time of installation.

F.6 Condition of supporting chamber

Before fixing the manhole top or gully top, operatives should ensure that the chamber upon which it is to be installed is in a sound condition, and can safely carry the traffic or pedestrian load to be transferred to it by the manhole top or gully top. All appropriate repairs or renovation of the supporting structure of an existing chamber should be undertaken before the installation of a new manhole top or gully top.

F.7 Fixing of manhole tops or gully tops

The structure of the chamber and/or local conditions and practice can require a particular type of frame and/or frame embedment. A wide variety of frame designs and methods of support for gratings and manhole covers are available. Therefore, when installing a manhole top or gully top, operatives should ensure that:

- the manhole top or gully top is fixed in accordance with the manufacturer's recommendations;
- there is adequate bearing of the frame on the chamber or on the structure of the adjacent paved surface, (as required by local practice);
- the frame has appropriate anchoring and sound anchoring points (if specified);
- the upper surface of the manhole top or gully top is appropriately aligned to the adjacent paved surface; and
- the manhole top or gully top is soundly fixed in place and supported, such that it will not move when subject to traffic loading.

F.8 Post installation check and cleaning

After the installation of the manhole top or gully top has been completed, and before exposing it to traffic, the installer should thoroughly clean all elements of the manhole top or gully top and its surroundings and carry out a check to ensure that all of its features function correctly.

In particular the following aspects of the installation should be checked /inspected:

- adequate curing time has elapsed for all bedding materials;
- the frame is secured in place;
- the cover or grating is stable within its frame and will not be disturbed by the action of traffic;
- there is no inappropriate interference between seatings or flanges of the cover or grating, and its frame;
- all additional features function correctly, e.g. hinges and locks;

- any cushioning inserts are properly fixed in place and function correctly; and
- any feature which locks the grating or manhole cover in an open position is functioning correctly and in accordance with the manufacturer's instructions.

Any abnormalities should be rectified before the manhole top or gully top is exposed to traffic.

Annex G (informative)

Explanations on testing of manhole tops with multiple covers and testing the skid resistance

G.1 Explanation to A.4

For testing manhole tops and gully tops with multiple triangular covers comments on the draft standard have been received that for such covers the application of test load should be changed to take into consideration new situations in heavy load traffic. At the same time comments were made that test methods modified in comparison with the current standard test would exclude products already legally existing on the market. At that stage it was not possible anymore to develop and validate new test methods applicable for both situations. Therefore, the test for triangular covers as specified in EN 124:1994 and validated in practice was maintained in the new edition of the standard. At the same time it was decided to prepare a new test method for the test of triangular and multiple rectangular covers and to publish it in a separate part of EN 124 series. If in special cases, until the availability of this part, and if requested by the purchaser to carry out additional tests for significant applications, these tests should be subject to additional agreements between purchaser and manufacturer and are not covered by EN 124 (all parts).

G.2 Explanation to 7.4.2

For microstructured surfaces the pendulum test in accordance with EN 13036-4 is used for testing the skid resistance of surfaces of manhole covers with textured depth below 2,0 mm for measuring the unpolished skid resistance value (USRV).

The applicability of the pendulum test method is not ensured for testing surfaces of manhole covers with non-homogeneous surface characteristics, e.g. raised pattern, dolly pointed, tooled, shot blasted (exceeding 1,2 mm mean texture depth) surfaces containing ridges or grooves, or are rough textured. Such surfaces cannot be reliably tested (see EN 13036-4). Further research is necessary to achieve reliable measurements. The results will be included in the next revision of the standard.

Taking into account that EN 124 (all parts) covers only manhole tops and gully tops with clear openings smaller than 1 000 mm the requirements for skid resistance of non-homogeneous surface characteristics were covered by the description of raised pattern with a height of studs, etc. above 1,5 mm (accuracy of measurement according to 8.4.13 b) included) defined in EN 124-1 (for example raised pattern, dolly pointed, tooled, shot blasted and concrete) or by defined concrete surfaces.

Taking into account the stable behaviour of the materials specified in the standard and the experience in many European countries on the macro structured surfaces which has been gained over a long period of time (more than 50 years) the skid resistance of such surfaces will be assessed without testing but by measuring the height of the structure and the method (raised pattern, coarse surface or unpolished concrete) declared against the minimum values specified in the standard.

Because a validated European test method for measuring the skid resistance value of the macro surfaces is not yet available the raised pattern of the manhole top was described and defined to cover the skid resistance.

For the raised pattern of manhole tops and gully tops as defined in the standard and unpolished concrete surfaces together with the stable behaviour of the material used, experience has been gained over a long period of time and covers the skid resistance.

Bibliography

- [1] EN 1253 (all parts), *Gullies for buildings*
- [2] EN 1433, *Drainage channels for vehicular and pedestrian areas — Classification, design and testing requirements, marking and evaluation of conformity*
- [3] EN 16323, *Glossary of wastewater engineering terms*

British Standards Institution (BSI)

BSI is the national body responsible for preparing British Standards and other standards-related publications, information and services.

BSI is incorporated by Royal Charter. British Standards and other standardization products are published by BSI Standards Limited.

About us

We bring together business, industry, government, consumers, innovators and others to shape their combined experience and expertise into standards-based solutions.

The knowledge embodied in our standards has been carefully assembled in a dependable format and refined through our open consultation process. Organizations of all sizes and across all sectors choose standards to help them achieve their goals.

Information on standards

We can provide you with the knowledge that your organization needs to succeed. Find out more about British Standards by visiting our website at bsigroup.com/standards or contacting our Customer Services team or Knowledge Centre.

Buying standards

You can buy and download PDF versions of BSI publications, including British and adopted European and international standards, through our website at bsigroup.com/shop, where hard copies can also be purchased.

If you need international and foreign standards from other Standards Development Organizations, hard copies can be ordered from our Customer Services team.

Subscriptions

Our range of subscription services are designed to make using standards easier for you. For further information on our subscription products go to bsigroup.com/subscriptions.

With **British Standards Online (BSOL)** you'll have instant access to over 55,000 British and adopted European and international standards from your desktop. It's available 24/7 and is refreshed daily so you'll always be up to date.

You can keep in touch with standards developments and receive substantial discounts on the purchase price of standards, both in single copy and subscription format, by becoming a **BSI Subscribing Member**.

PLUS is an updating service exclusive to BSI Subscribing Members. You will automatically receive the latest hard copy of your standards when they're revised or replaced.

To find out more about becoming a BSI Subscribing Member and the benefits of membership, please visit bsigroup.com/shop.

With a **Multi-User Network Licence (MUNL)** you are able to host standards publications on your intranet. Licences can cover as few or as many users as you wish. With updates supplied as soon as they're available, you can be sure your documentation is current. For further information, email bsmusales@bsigroup.com.

BSI Group Headquarters

389 Chiswick High Road London W4 4AL UK

Revisions

Our British Standards and other publications are updated by amendment or revision.

We continually improve the quality of our products and services to benefit your business. If you find an inaccuracy or ambiguity within a British Standard or other BSI publication please inform the Knowledge Centre.

Copyright

All the data, software and documentation set out in all British Standards and other BSI publications are the property of and copyrighted by BSI, or some person or entity that owns copyright in the information used (such as the international standardization bodies) and has formally licensed such information to BSI for commercial publication and use. Except as permitted under the Copyright, Designs and Patents Act 1988 no extract may be reproduced, stored in a retrieval system or transmitted in any form or by any means – electronic, photocopying, recording or otherwise – without prior written permission from BSI. Details and advice can be obtained from the Copyright & Licensing Department.

Useful Contacts:

Customer Services

Tel: +44 845 086 9001

Email (orders): orders@bsigroup.com

Email (enquiries): cservices@bsigroup.com

Subscriptions

Tel: +44 845 086 9001

Email: subscriptions@bsigroup.com

Knowledge Centre

Tel: +44 20 8996 7004

Email: knowledgecentre@bsigroup.com

Copyright & Licensing

Tel: +44 20 8996 7070

Email: copyright@bsigroup.com



...making excellence a habit.™